



US00D961745S

(12) **United States Design Patent**
Zhang

(10) **Patent No.:** **US D961,745 S**

(45) **Date of Patent:** **** Aug. 23, 2022**

(54) **HEATER**

(71) Applicant: **Dongguan Jiuzuanwang Electronic Commerce Co., Ltd., Dongguan (CN)**

(72) Inventor: **Huayong Zhang, Hunan Province (CN)**

(**) Term: **15 Years**

(21) Appl. No.: **29/800,597**

(22) Filed: **Jul. 22, 2021**

(51) **LOC (13) Cl.** **23-03**

(52) **U.S. Cl.**
USPC **D23/332**

(58) **Field of Classification Search**

USPC D23/314, 317, 318, 319, 320, 321, 322,
D23/323, 329, 330, 331, 332, 334, 335,
D23/333, 336, 337, 338, 339, 340, 341,
D23/342, 411, 412, 356, 358, 359, 363,
D23/328

CPC F24H 3/00; F24H 3/0411; F24H 3/0417;
F24H 9/0063; F24H 9/0073; F24H 9/02;
F24H 3/082; F24H 9/2071; F24H 3/002;
F24H 3/02; F24H 3/04; F04D 17/04;
F04D 25/08; F04D 25/10; F04D 5/00;
H05B 3/008

See application file for complete search history.

(56) **References Cited**

U.S. PATENT DOCUMENTS

D461,002 S * 7/2002 Christianson D23/364
D571,445 S * 6/2008 Vandenbelt D23/364

D675,303 S * 1/2013 Raupach D23/364
D797,272 S * 9/2017 Poindexter D23/364
D841,140 S * 2/2019 Chen D23/336
D846,102 S 4/2019 Pellerin et al.
2017/0284701 A1* 10/2017 Wang F24H 3/002

* cited by examiner

Primary Examiner — Ania Aman

(57) **CLAIM**

The ornamental design for a heater, as shown and described.

DESCRIPTION

FIG. 1 is a front and top perspective view of a heater, showing my new design;

FIG. 2 is a rear and bottom perspective view thereof;

FIG. 3 is a front elevation view thereof;

FIG. 4 is a rear elevation view thereof;

FIG. 5 is a left side elevation view thereof;

FIG. 6 is a right side elevation view thereof;

FIG. 7 is a top plan view thereof;

FIG. 8 is a bottom plan view thereof;

FIG. 9 is an enlarged view of a portion labeled, 'FIG. 9' in FIG. 1; and,

FIG. 10 is an enlarged view of a portion labeled, 'FIG. 10' in FIG. 1.

The broken lines in the figures illustrate portions of the heater that form no part of the claimed design. The dash dot dash lines in FIGS. 1, 9 and 10 are for the purpose of depicting the cut line of the enlarged view and form no part of the claim.

1 Claim, 10 Drawing Sheets

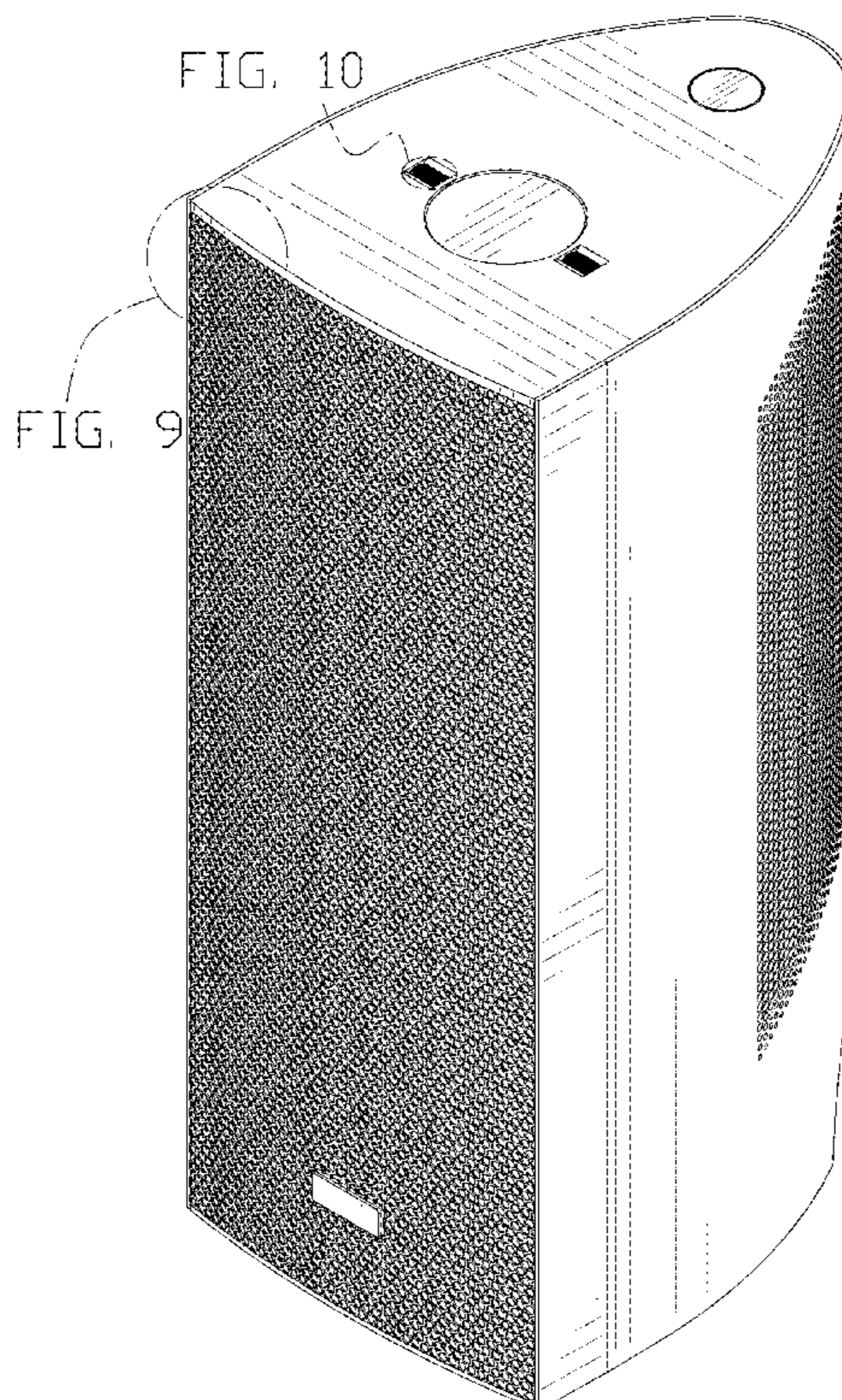

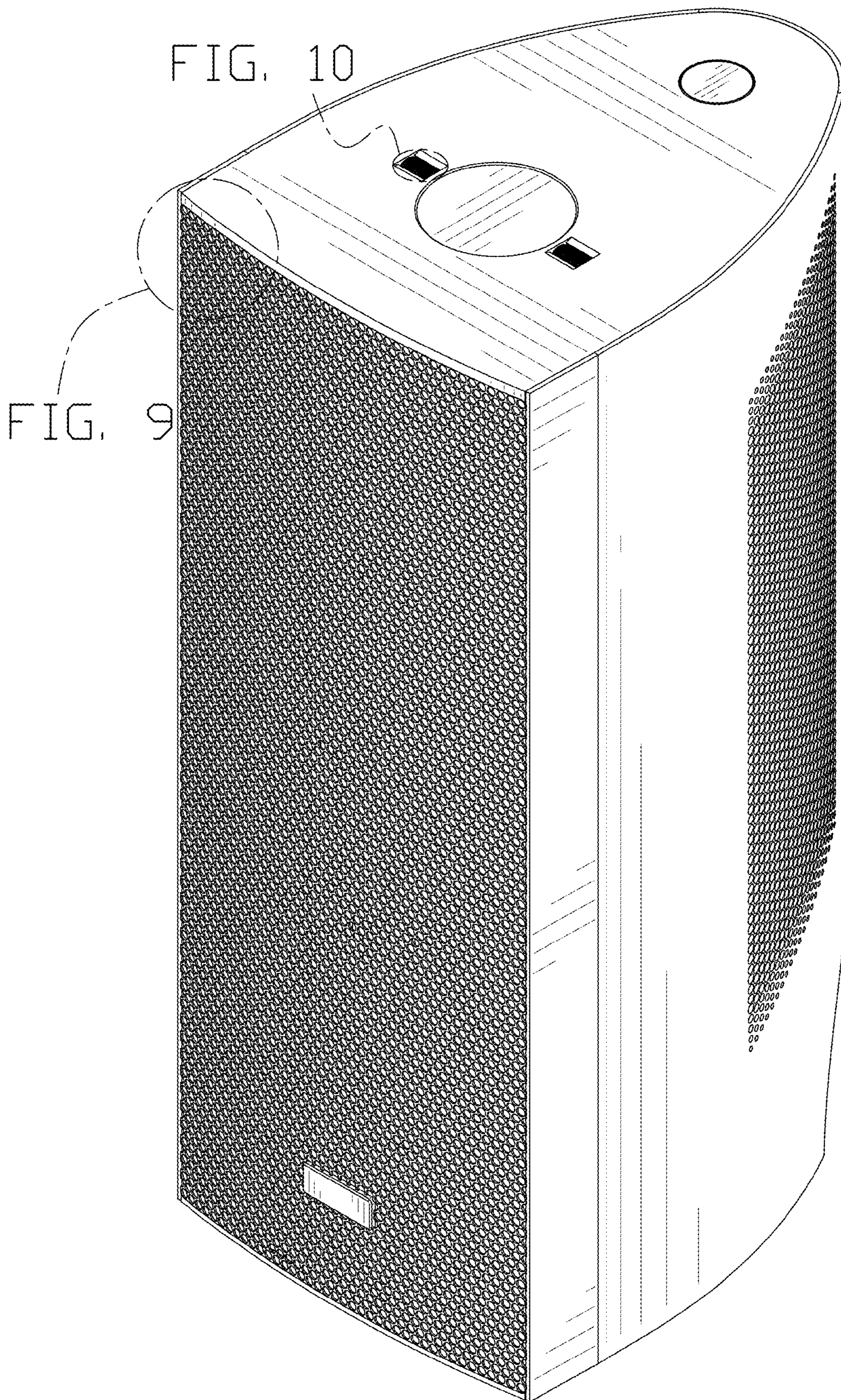

FIG. 10

FIG. 9

FIG. 1

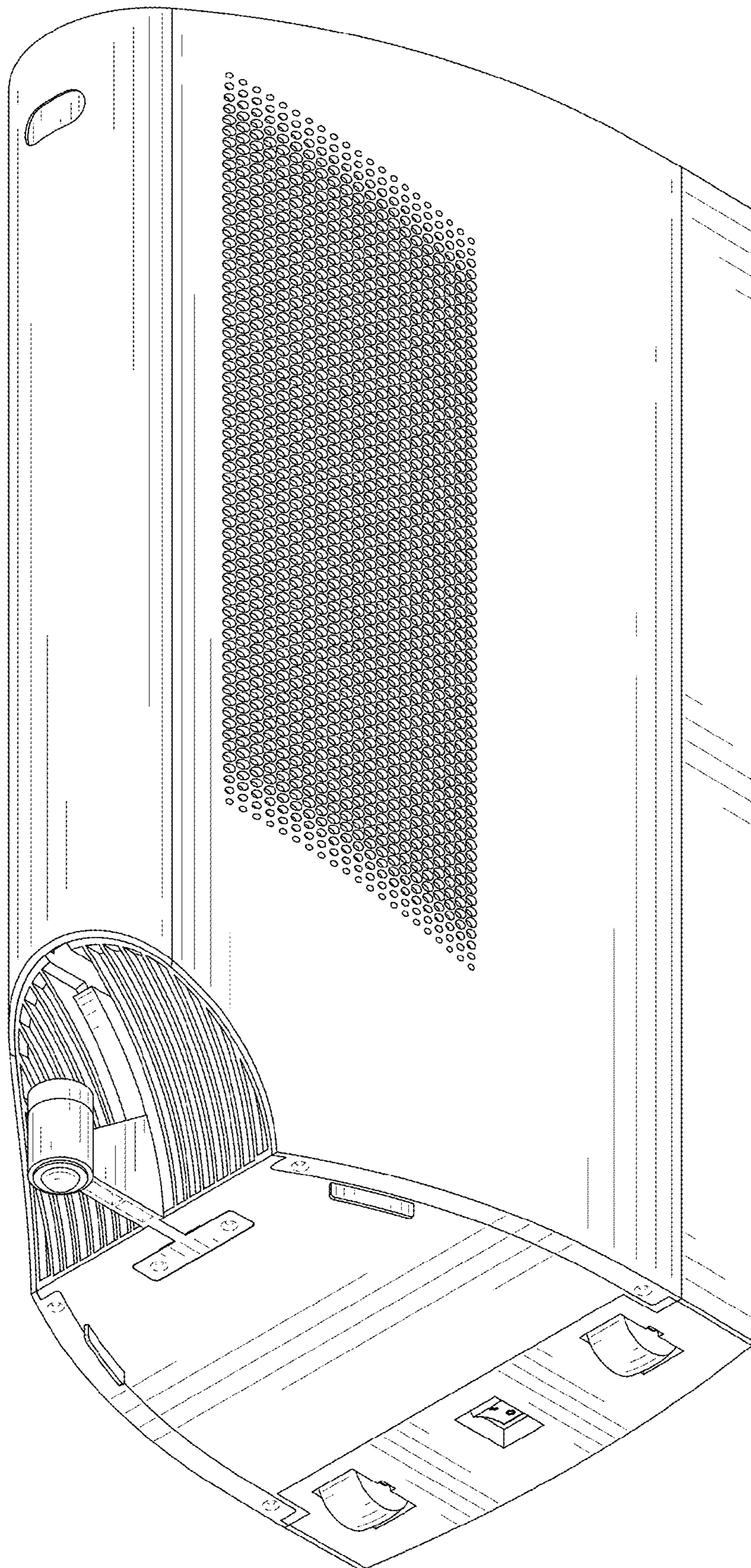

FIG. 2

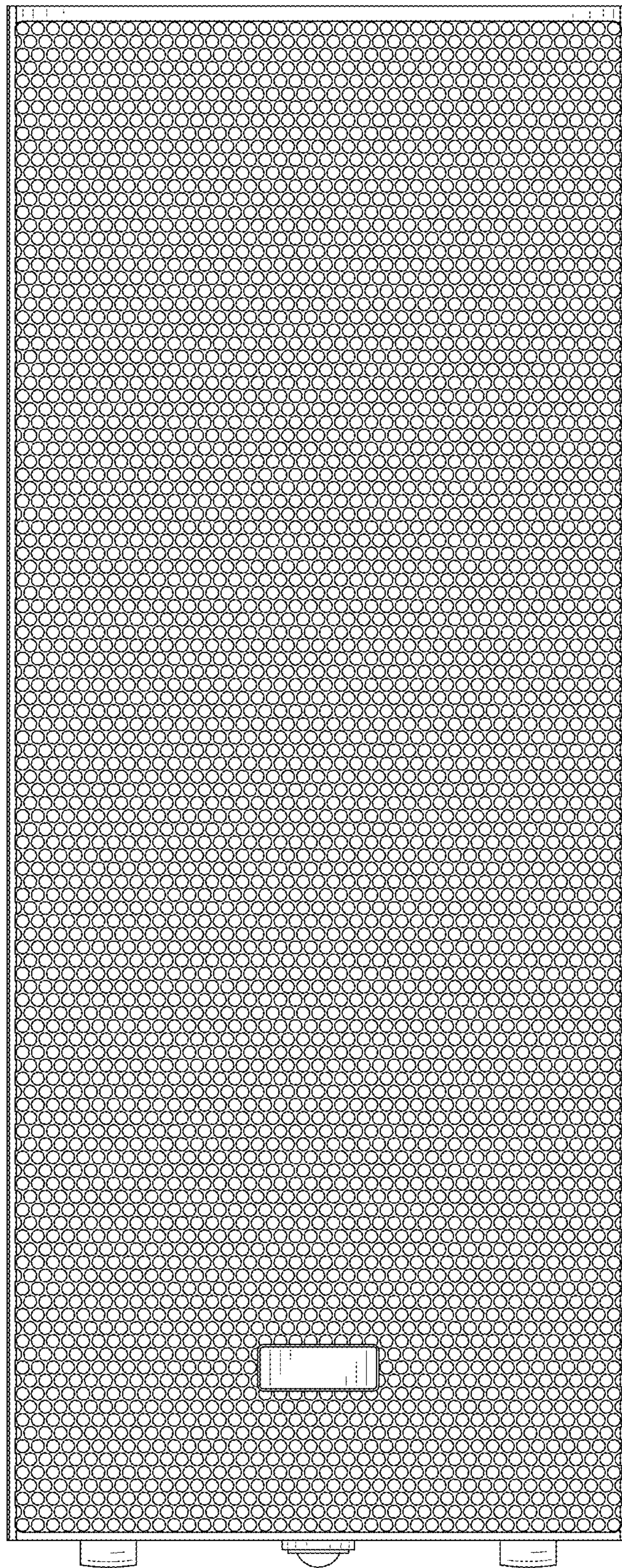

FIG. 3

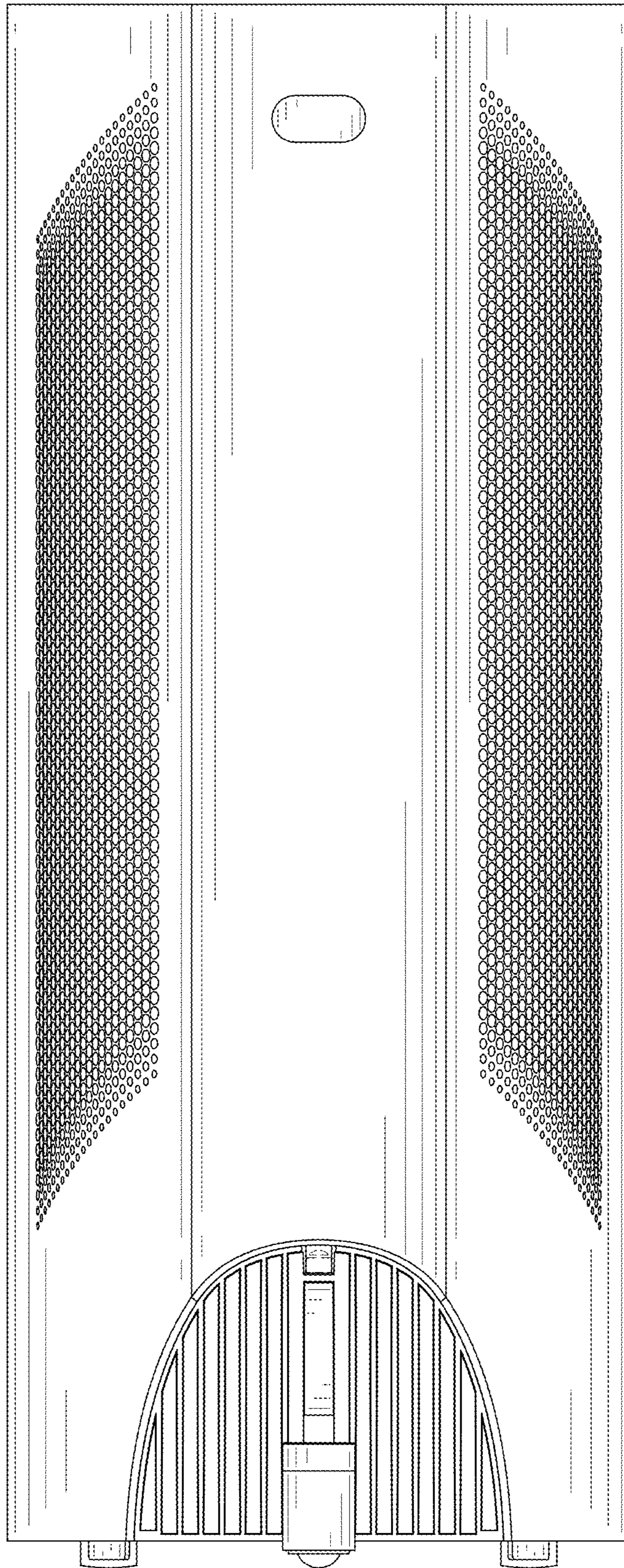

FIG. 4

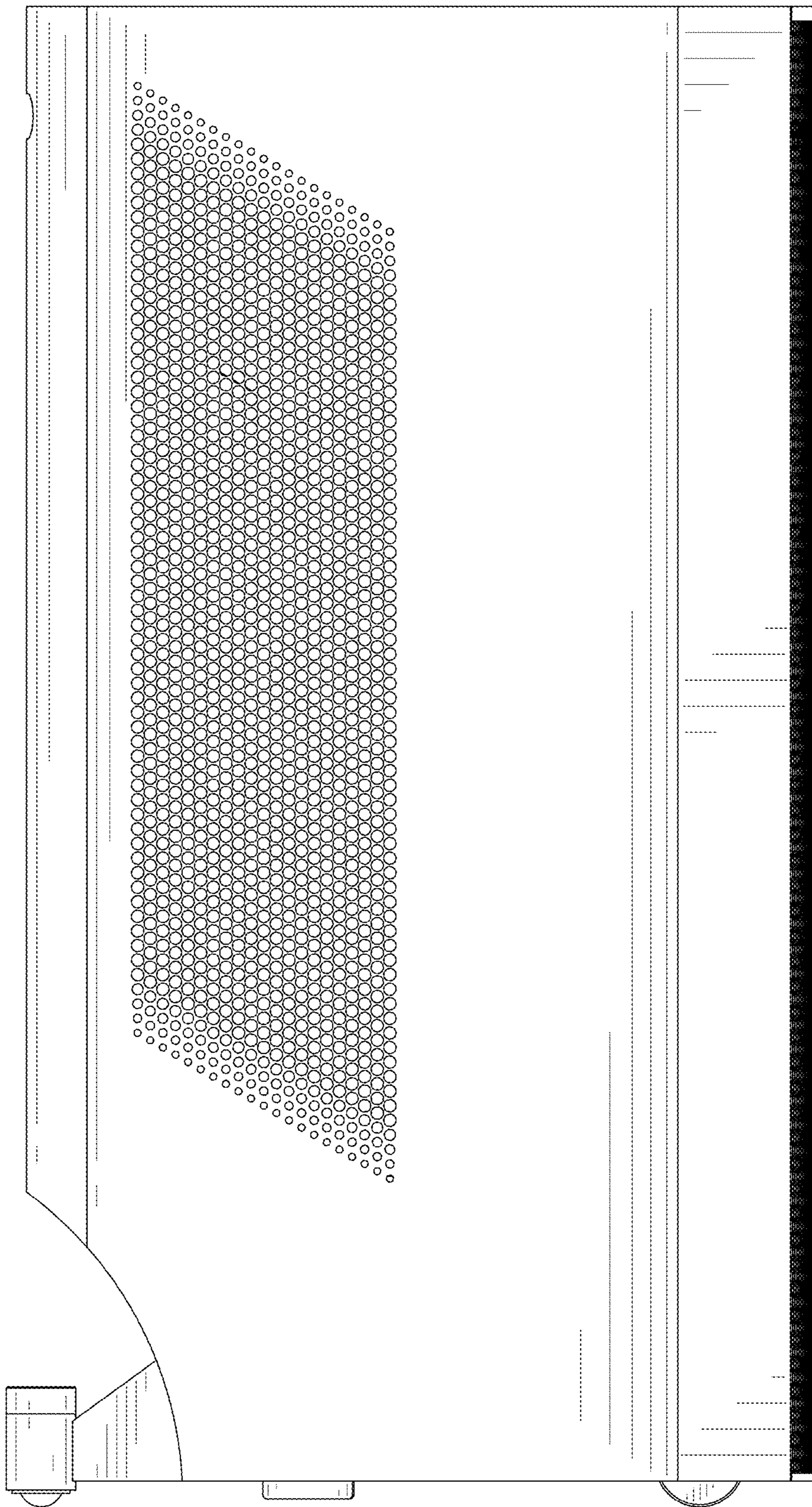

FIG. 5

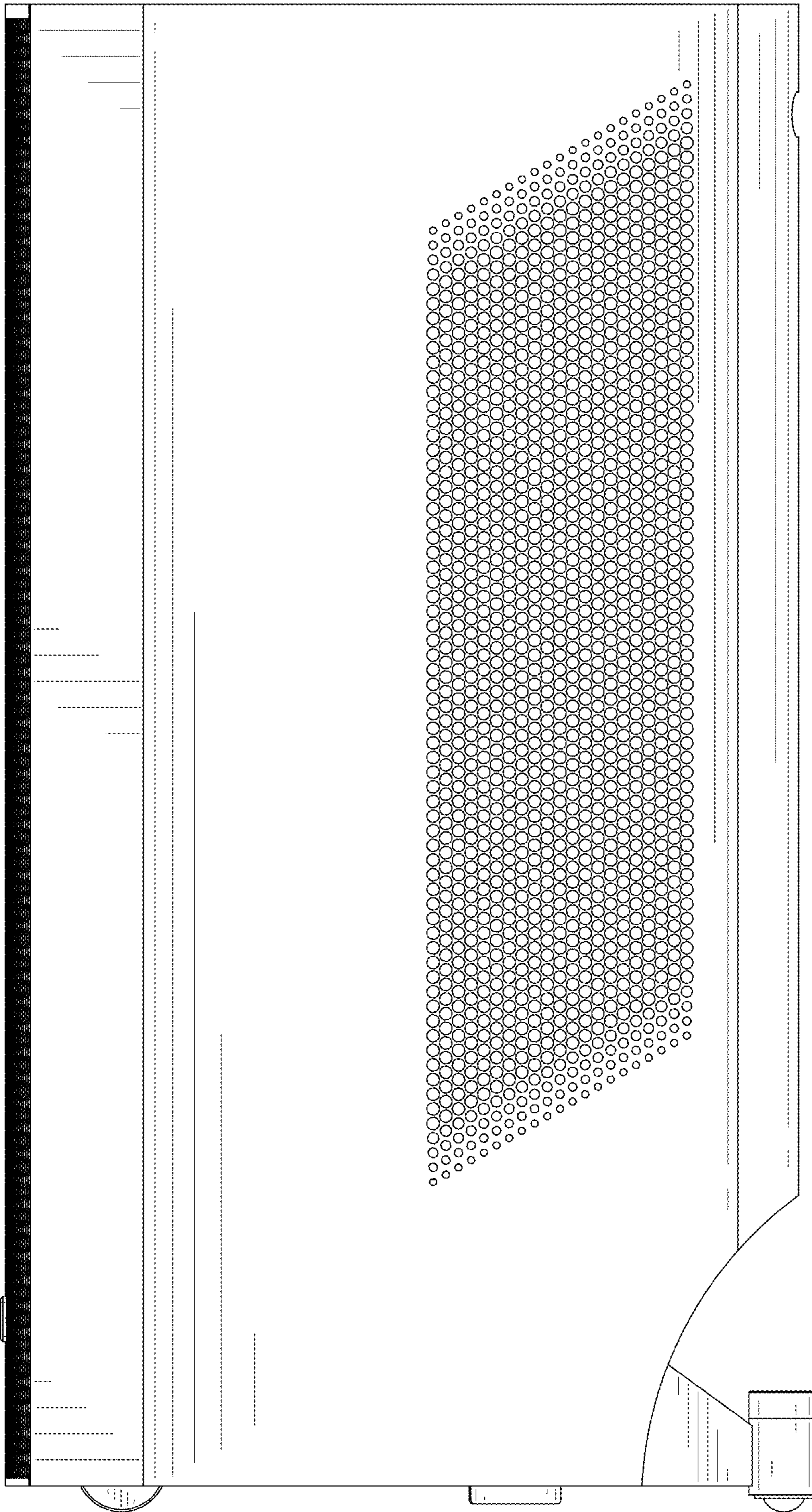

FIG. 6

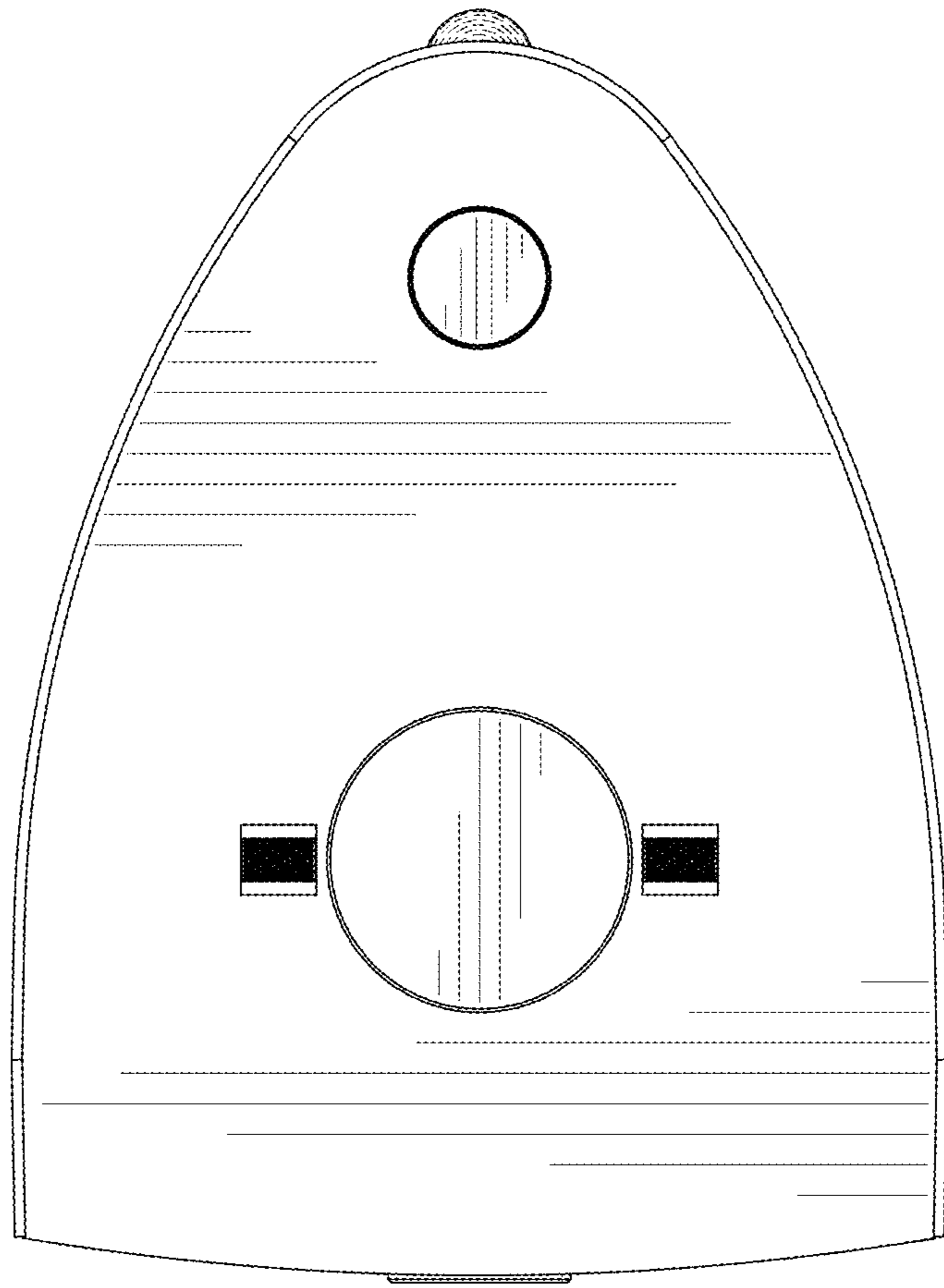

FIG. 7

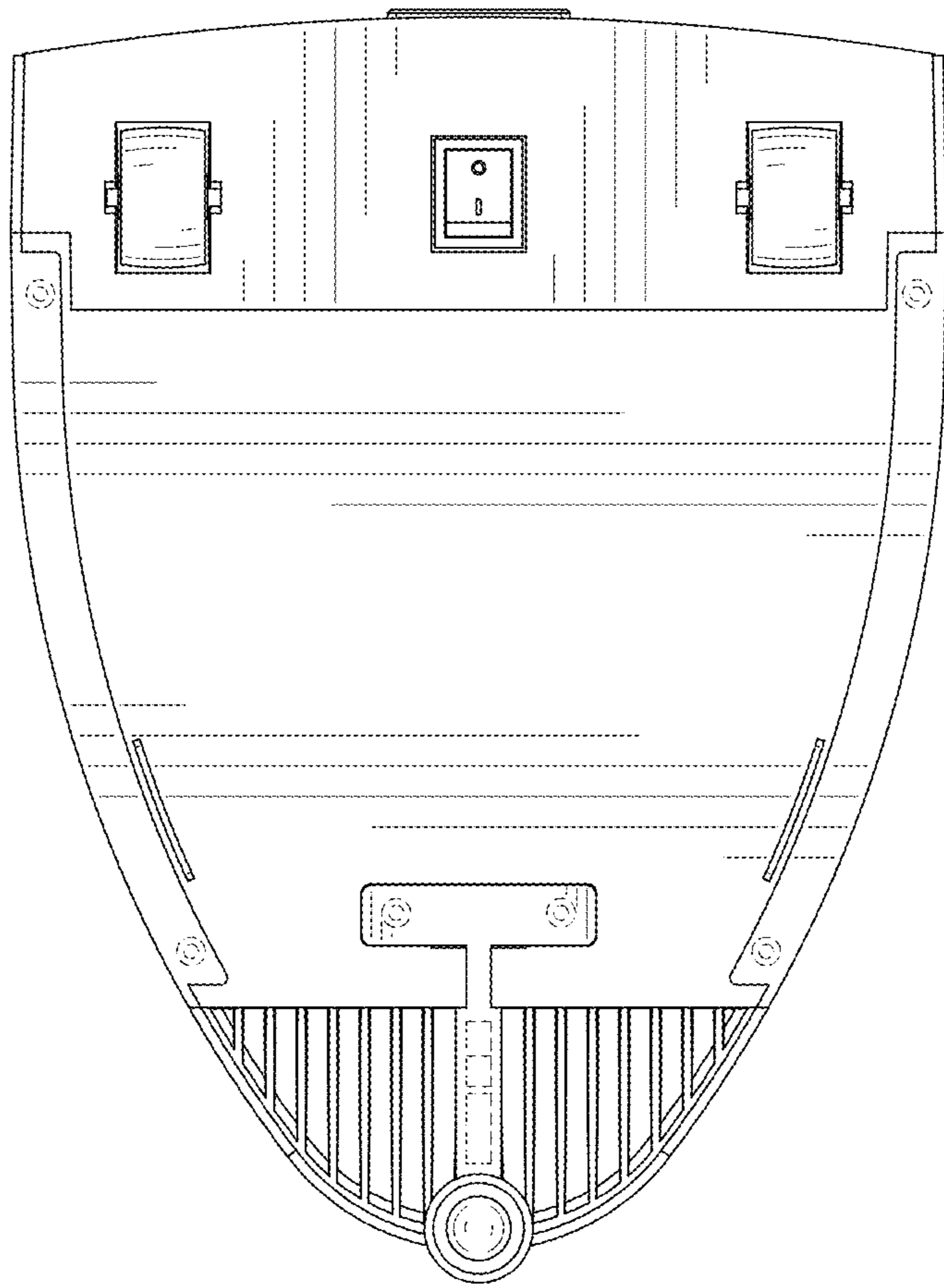

FIG. 8

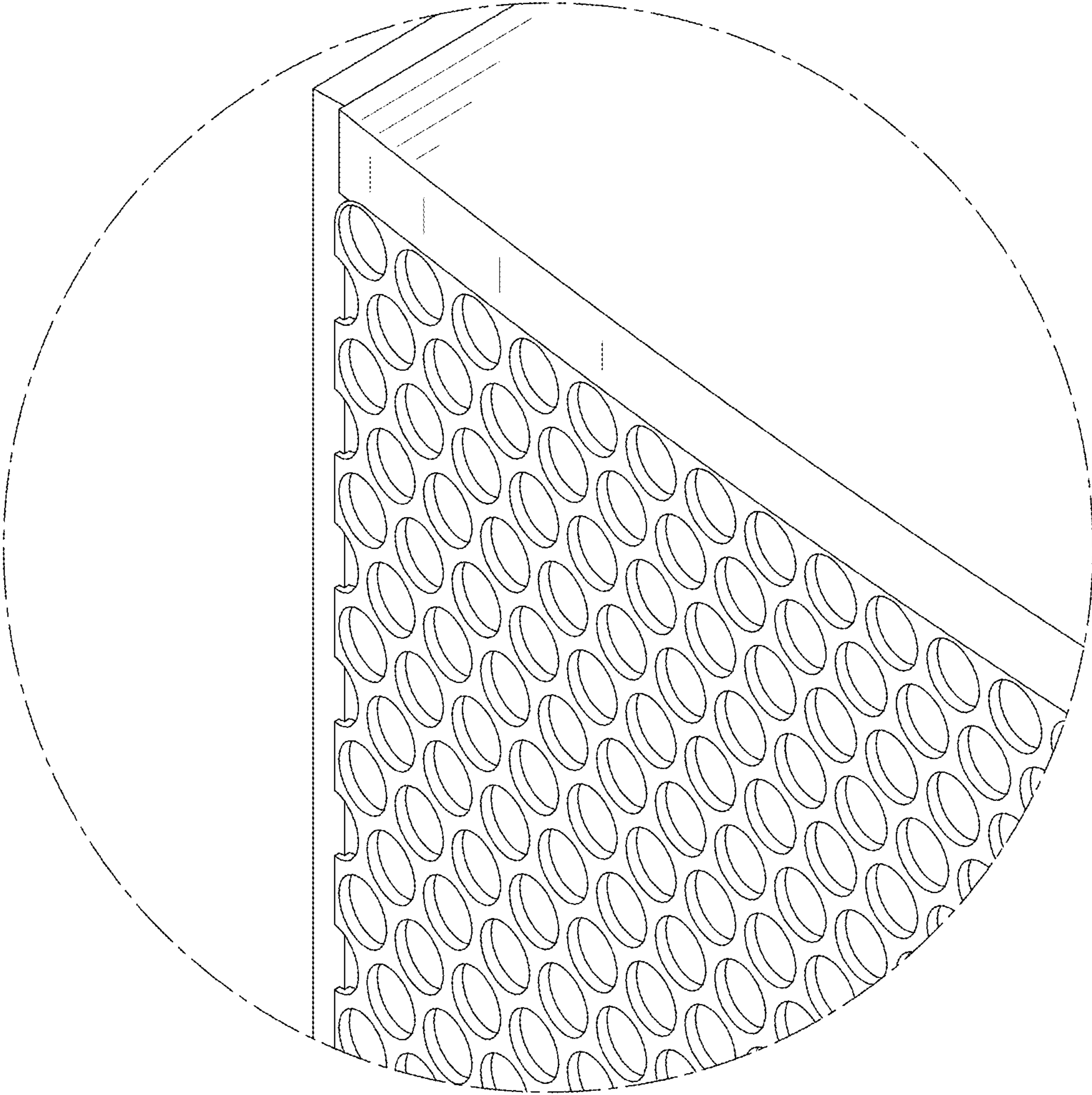

FIG. 9

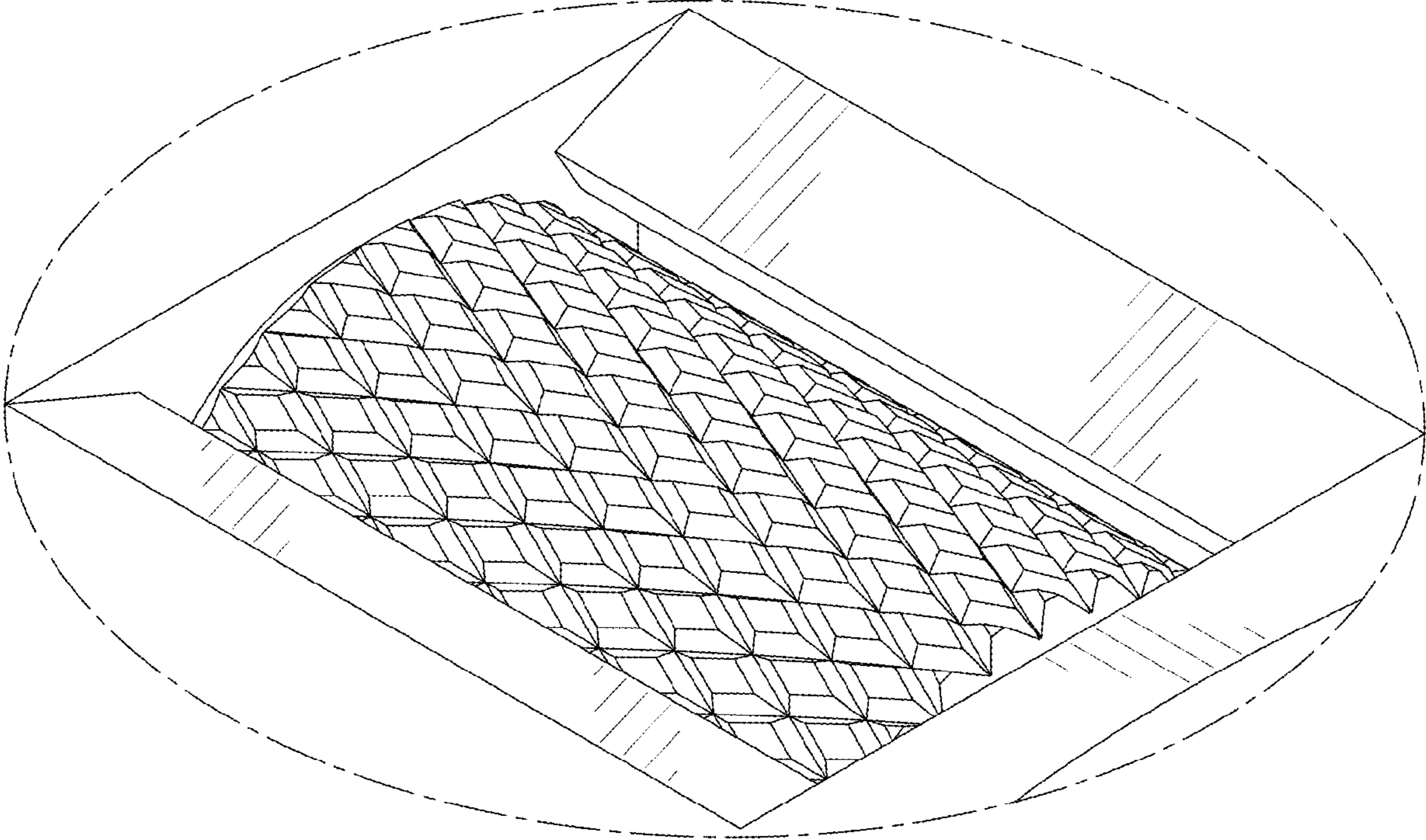

FIG. 10