



US00D961674S

(12) **United States Design Patent**
Shmal

(10) **Patent No.:** **US D961,674 S**
(45) **Date of Patent:** **** Aug. 23, 2022**

(54) **BELT FOR A PRINTER**

(71) Applicant: **LANDA CORPORATION LTD.**,
Rehovot (IL)

(72) Inventor: **Sergei Shmal**, Rehovot (IL)

(73) Assignee: **LANDA CORPORATION LTD.**,
Rehovot (IL)

(**) Term: **15 Years**

(21) Appl. No.: **29/687,917**

(22) Filed: **Apr. 17, 2019**

(51) **LOC (13) Cl.** **18-02**

(52) **U.S. Cl.**
USPC **D18/56**

(58) **Field of Classification Search**

USPC D15/122, 135-138, 141, 66, 73, 76-78,
D15/146, 150, 143, 89; D18/53, 59, 50,
D18/14, 19, 54-57, 36-45, 34.4, 34.5,
D18/34.6, 18, 51, 34.1, 99;
D14/301-303, 307, 345, 420-425, 462;
D6/691.4, 675, 708, 671, 520-523, 580;
D34/35, 29, 1; D7/700, 554.3, 637;
D3/304, 313; D9/424; D8/313, 314,
D8/301, 380, 382, 358, 354; D10/119.1;
D32/19, 25, 32, 21; D4/128, 102, 122;
D25/157, 160, 162, 119; D19/1, 5, 113,
D19/190, 191, 104, 107, 192, 202, 99,
D19/100
CPC B41J 2/14; B41J 2/01; B41J 2/22; B41J
1/54; B41J 3/4073; B41J 3/4078; B41J
11/007; B41J 11/0055; B41J 29/38; B41J
2002/012; B41F 17/22; B41F 17/003;
B41F 17/38; B28B 1/001; B65H 5/02;
G03G 15/08; G03G 15/0891; G03G
15/0875; G03G 2215/0827; G03G
2215/0855; G03G 21/1842

See application file for complete search history.

(56) **References Cited**

U.S. PATENT DOCUMENTS

1,893,823 A 1/1933 Legat
1,899,479 A 2/1933 Prentice
(Continued)

FOREIGN PATENT DOCUMENTS

GB 9005606977-0003 * 8/2018

OTHER PUBLICATIONS

Landa—Nanographic press, published May 3, 2021 [online], [retrieved May 5, 2021], Available from Internet, URL: <https://imieurope.com/inkjet-blog/2016/1/20/landa-steals-the-biggest-print-show-on-earth>.*

Primary Examiner — Leanne Was-Englehart

(74) *Attorney, Agent, or Firm* — Momentum IP Group;
Marc Van Dyke

(57) **CLAIM**

The ornamental design for a belt for a printer, as shown and described.

DESCRIPTION

FIG. 1 is a perspective view of a belt for a printer showing the new design;
FIG. 2 is a right view thereof;
FIG. 3 is a left view thereof;
FIG. 4 is a front view thereof;
FIG. 5 is a rear view thereof;
FIG. 6 is a top view thereof; and,
FIG. 7 is a bottom view thereof.

Broken lines shown in the drawings depict portions of the belt for a printer that form no part of the claimed design. The belt for a printer is shown with symbolic breaks in its length and width. The symbolic breaks are indicated by dot-dash boundary lines, which indicate the boundaries of the claimed design. The appearance of any portion of the article between the boundary lines forms no part of the claimed design.

The boundary lines form no part of the claimed design.

1 Claim, 5 Drawing Sheets

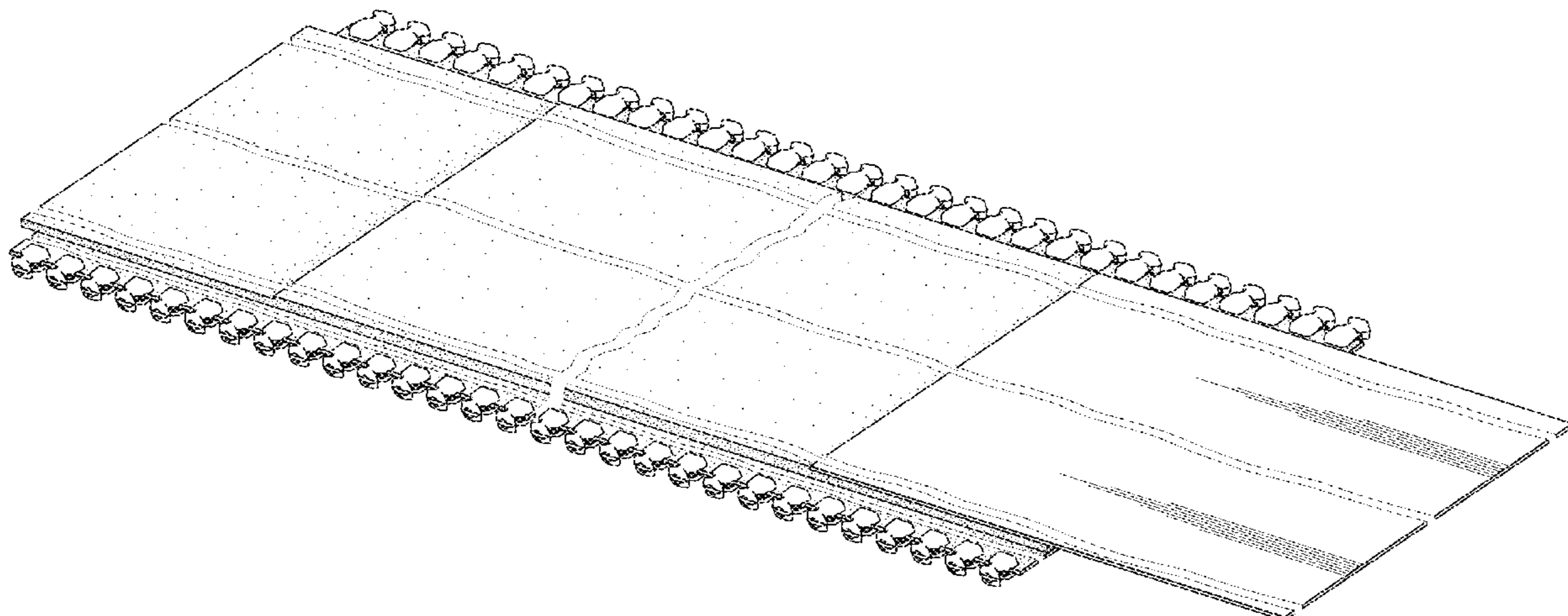

(56)

References Cited

U.S. PATENT DOCUMENTS

2,060,830 A 11/1936 Silberman
 2,068,500 A 1/1937 Marinsky
 D126,195 S * 4/1941 Cohen D34/29
 2,385,020 A * 9/1945 Morin A44B 19/04
 24/410
 2,537,313 A 1/1951 Morin
 2,607,715 A 8/1952 Waldes
 2,718,047 A 9/1955 Waldes
 2,768,922 A 10/1956 Klein
 2,814,847 A 12/1957 Zbinden
 2,854,722 A 10/1958 Ruding
 3,641,634 A 2/1972 Asai
 4,044,432 A 8/1977 Ebata
 4,099,301 A 7/1978 Fujisaki
 D265,606 S 8/1982 Kasai
 4,359,008 A 11/1982 Newman
 D274,016 S 5/1984 Kasai
 4,487,645 A * 12/1984 Weston B41J 13/12
 156/157
 D284,330 S 6/1986 Yoshikawa et al.
 D288,255 S * 2/1987 Bode D34/29
 D291,777 S * 9/1987 Lapeyre D34/29
 D293,225 S 12/1987 Hasegawa
 4,884,826 A * 12/1989 Slagsvol B42D 1/005
 281/2
 D326,433 S 5/1992 Takizawa et al.
 5,246,100 A * 9/1993 Stone F16G 3/00
 198/844.2
 5,745,960 A 5/1998 Dishner et al.
 D407,668 S 4/1999 Okeya
 5,917,508 A * 6/1999 Lopez B41J 2/17509
 347/4
 D420,777 S * 2/2000 Damkjaer D34/35
 D452,081 S * 12/2001 Rowan D6/300
 6,403,207 B1 * 6/2002 Weder A01G 5/04
 229/87.18
 6,457,709 B1 * 10/2002 Madsen B65H 5/021
 271/198
 D473,032 S * 4/2003 Altom D34/29
 D502,585 S * 3/2005 Damkjaer D34/29
 D586,395 S * 2/2009 Kang D19/113
 D586,396 S * 2/2009 Kang D19/113
 7,691,462 B2 * 4/2010 Erwin G09F 3/10
 428/40.1
 D617,565 S * 6/2010 Mischel, Jr. D6/300
 7,832,853 B2 11/2010 Nakashima
 D644,564 S 9/2011 Kojima et al.
 D672,687 S * 12/2012 Himi D11/221
 D673,077 S 12/2012 Fujita
 D680,166 S * 4/2013 Sato D19/1
 D700,865 S 3/2014 Miyazaki
 D700,866 S 3/2014 Miyazaki
 D700,867 S 3/2014 Miyazaki
 D700,868 S 3/2014 Miyazaki
 D701,141 S 3/2014 Miyazaki
 D701,142 S 3/2014 Miyazaki
 D710,748 S 8/2014 Takabayashi et al.
 D715,187 S 10/2014 Fujita et al.

D715,188 S 10/2014 Fujita et al.
 D715,189 S 10/2014 Fujita et al.
 D715,687 S 10/2014 Fujita et al.
 D715,688 S 10/2014 Fujita et al.
 D716,184 S 10/2014 Fujita et al.
 D724,996 S 3/2015 Hung
 D726,589 S 4/2015 Xie
 D731,359 S 6/2015 Xie
 D737,536 S * 8/2015 Baek D34/29
 D746,721 S 1/2016 Petronis
 D779,590 S * 2/2017 Pryor D19/1
 9,591,898 B2 3/2017 Burkhart-Day
 D786,350 S * 5/2017 Nakai D19/1
 D786,351 S * 5/2017 Nakai D19/1
 9,643,403 B2 5/2017 Landa et al.
 9,668,549 B2 6/2017 Tsuzuyama
 D118,022 S 1/2018 Poux
 9,854,880 B2 1/2018 Kojima et al.
 10,001,730 B1 * 6/2018 Gould, II G03G 15/1615
 D830,456 S * 10/2018 Costas D19/113
 D831,110 S * 10/2018 Costas D19/113
 10,434,761 B2 10/2019 Landa et al.
 D866,392 S * 11/2019 Cobb D11/221
 D888,286 S * 6/2020 Spear D25/138
 D893,348 S * 8/2020 Cheng D11/221
 10,759,953 B2 * 9/2020 Landa C09D 11/30
 10,926,532 B2 * 2/2021 Chechik B41J 2/01
 10,960,660 B2 * 3/2021 Landa B41M 5/0256
 D927,819 S * 8/2021 Graff D34/29
 D931,366 S * 9/2021 Chechik D18/56
 2003/0143362 A1 7/2003 Hsieh et al.
 2006/0204700 A1 * 9/2006 Kiraly G09F 3/0289
 428/40.1
 2007/0025768 A1 * 2/2007 Komatsu G03G 15/6564
 399/167
 2007/0029171 A1 * 2/2007 Nemedi B65G 15/56
 198/841
 2009/0074492 A1 * 3/2009 Ito G03G 15/00
 399/388
 2010/0269312 A1 10/2010 Wagner et al.
 2011/0068025 A1 3/2011 Whittemore
 2013/0201237 A1 * 8/2013 Thomson B41J 11/008
 347/14
 2013/0228419 A1 * 9/2013 Baek, IV B65G 21/14
 198/615
 2015/0015650 A1 * 1/2015 Landa B41M 5/0256
 347/103
 2015/0157096 A1 6/2015 Mikuma et al.
 2015/0165759 A1 6/2015 Landa et al.
 2016/0075130 A1 3/2016 Landa et al.
 2016/0194865 A1 * 7/2016 Chou E04B 1/6129
 52/588.1
 2017/0151817 A1 * 6/2017 Takakusa B41J 3/28
 2018/0079201 A1 * 3/2018 Landa B41M 5/0256
 2018/0126726 A1 5/2018 Shmaiser et al.
 2019/0105906 A1 * 4/2019 Suzuki B41J 2/1714
 2019/0299660 A1 * 10/2019 Matsunaga B41J 3/28
 2019/0322108 A1 * 10/2019 Manes B41J 11/0085
 2020/0062002 A1 2/2020 Landa et al.
 2020/0290340 A1 9/2020 Chechik et al.

* cited by examiner

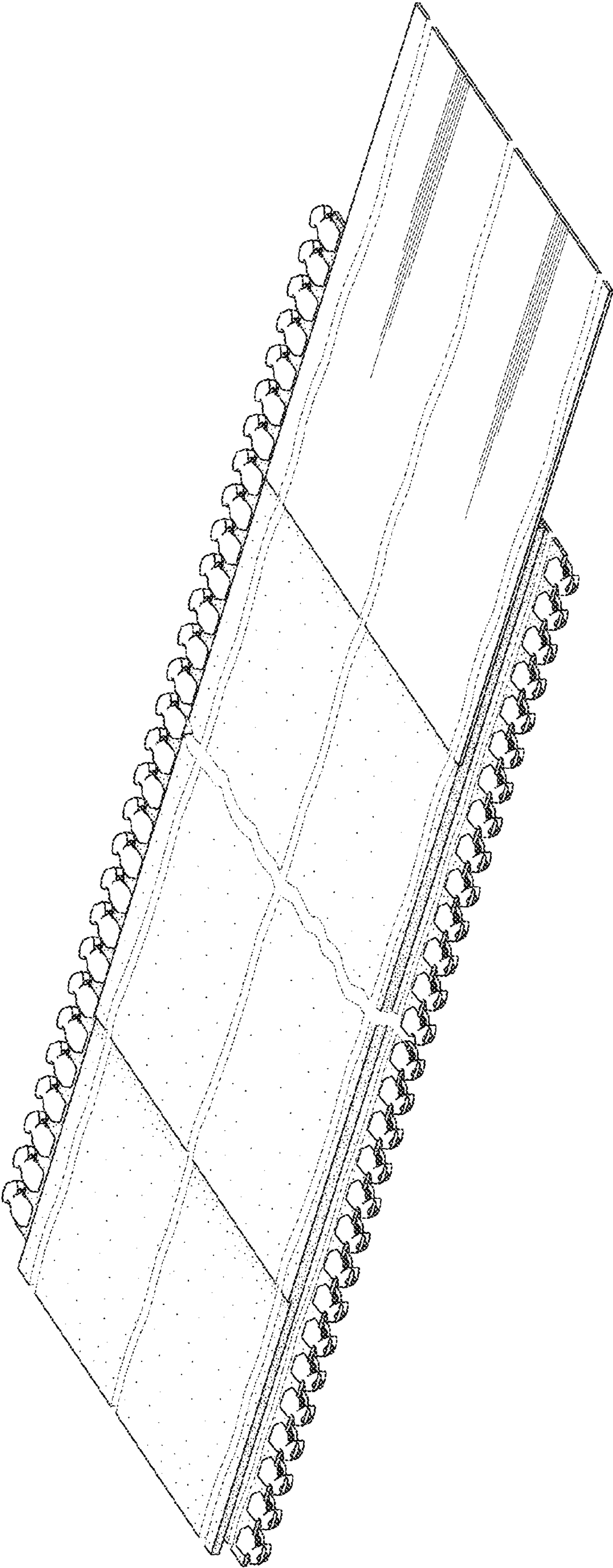

FIG. 1

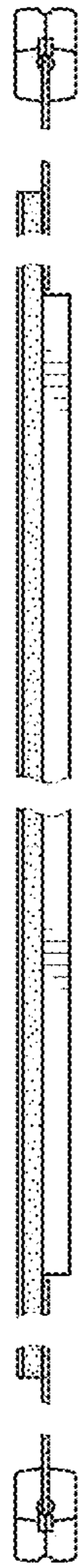

FIG. 2

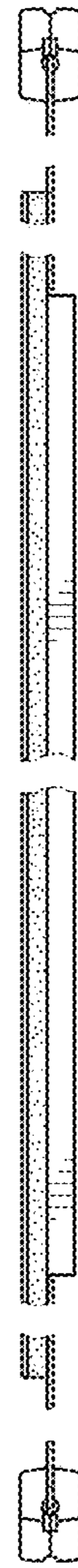

FIG. 3

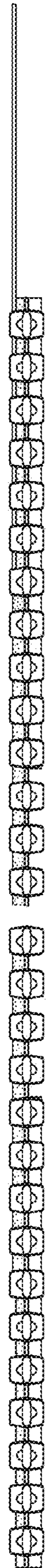

FIG. 4



FIG. 5

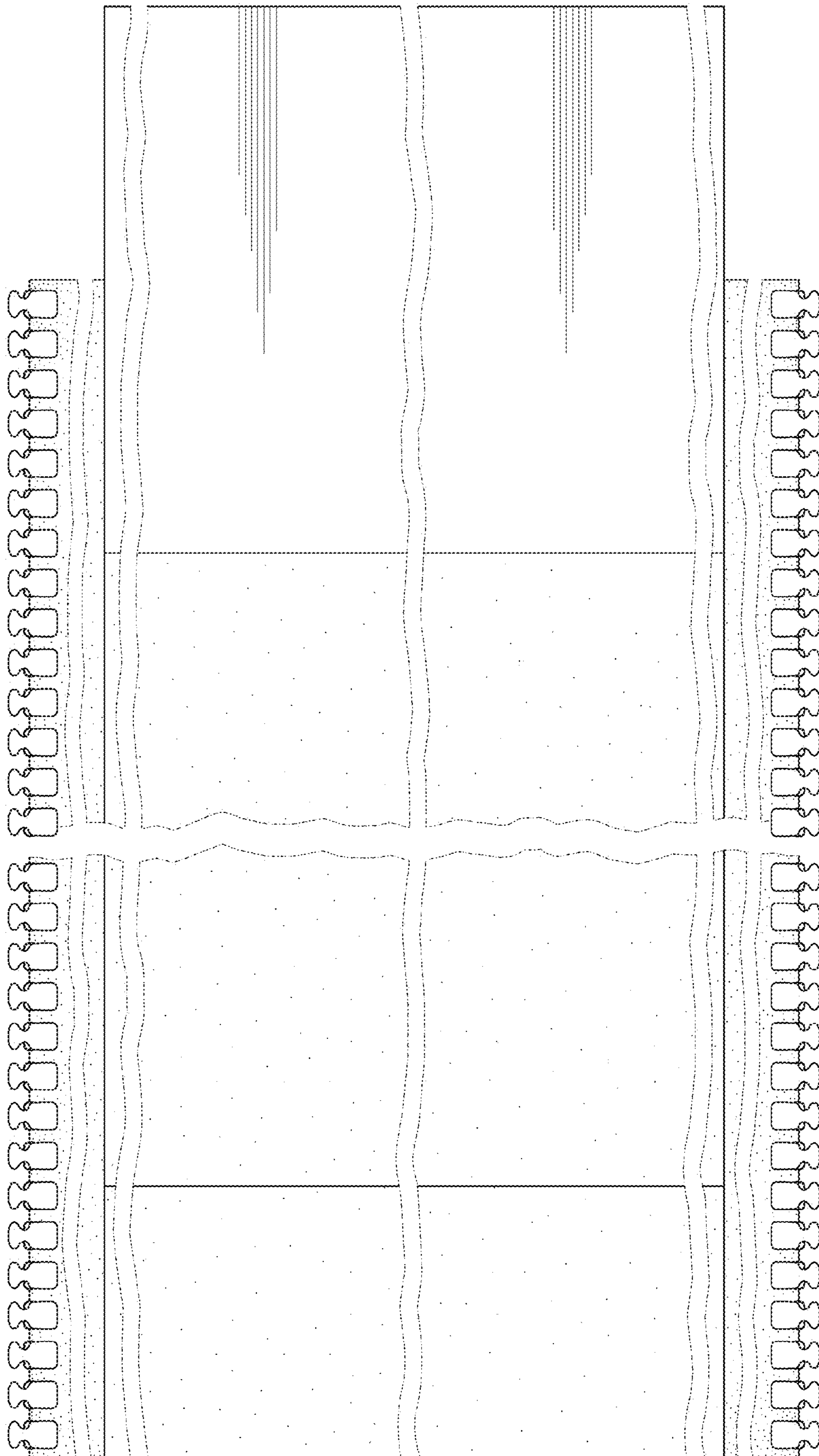

FIG. 6

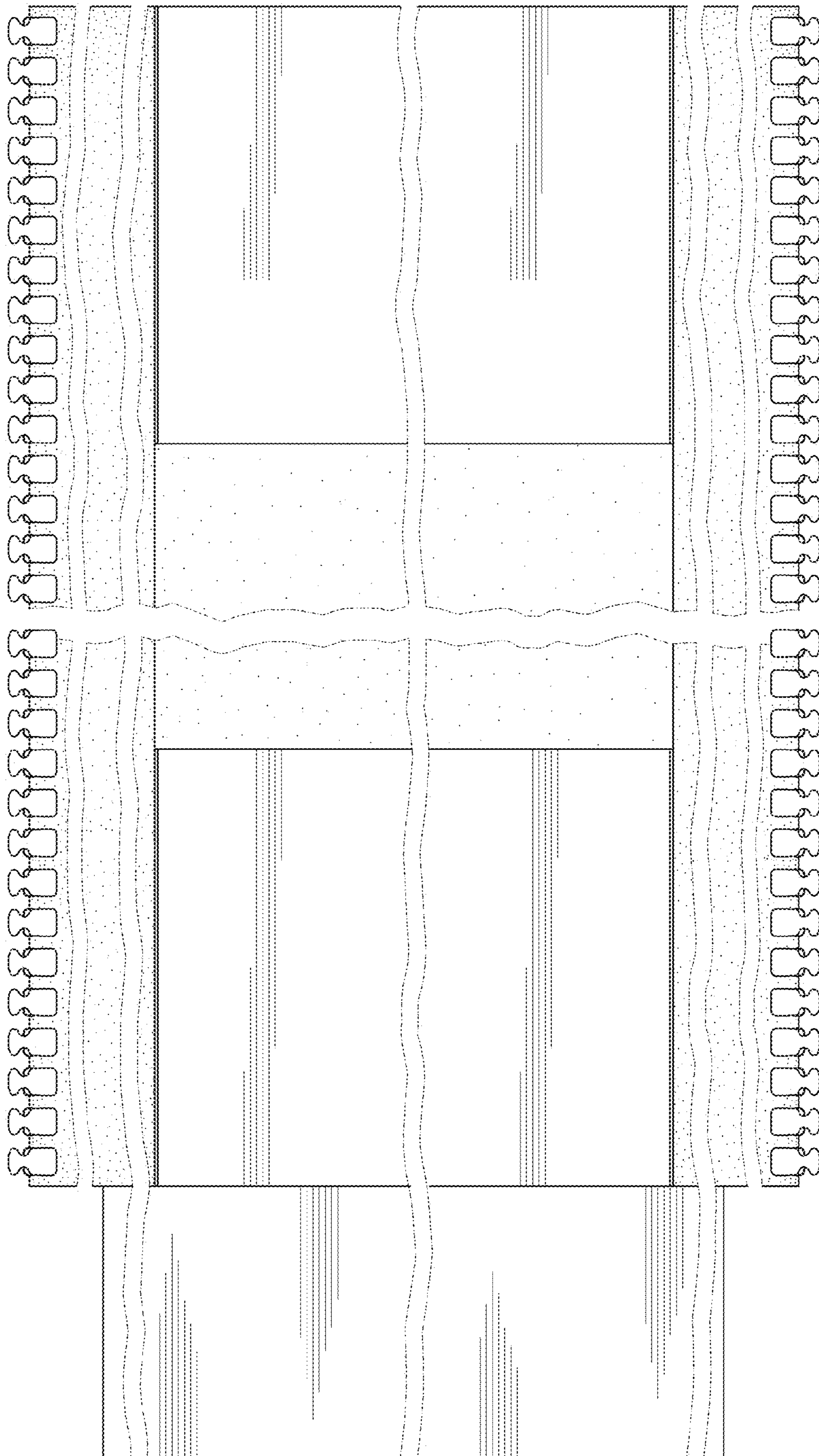

FIG. 7