



US00D960946S

(12) **United States Design Patent**  
**Mahaffey, Jr. et al.**

(10) **Patent No.:** **US D960,946 S**  
(45) **Date of Patent:** **\*\* Aug. 16, 2022**

(54) **CUTTER HEAD FOR GRINDING MACHINES AND THE LIKE**

(71) Applicant: **Dynatech Systems, Inc.**, Elyria, OH (US)

(72) Inventors: **Glenn Mahaffey, Jr.**, Elyria, OH (US);  
**Ronald Nealey**, Collins, OH (US)

(73) Assignee: **DYNATECH SYSTEMS, INC.**, Elyria, OH (US)

(\*\*) Term: **15 Years**

(21) Appl. No.: **29/818,867**

(22) Filed: **Dec. 10, 2021**

**Related U.S. Application Data**

(62) Division of application No. 29/721,914, filed on Jan. 24, 2020, now Pat. No. Des. 940,767.

(51) **LOC (13) Cl.** ..... **15-09**

(52) **U.S. Cl.**  
USPC ..... **D15/139**

(58) **Field of Classification Search**  
USPC ..... D7/409, 412; D8/20, 70, 95, 98, 99;  
D15/126, 133, 138, 139, 140  
CPC ..... B21D 17/04; B23D 45/044; B23B 5/162;  
B23B 5/163; B23K 7/006; B24D 7/06;  
B24D 7/12

See application file for complete search history.

(56) **References Cited**

**U.S. PATENT DOCUMENTS**

1,984,936 A	12/1934	Thure
2,349,949 A	5/1944	Farrell
3,376,673 A	4/1968	Metzger et al.
3,468,583 A	9/1969	Austin
3,585,761 A	6/1971	Hughes
3,612,611 A	10/1971	Ellis
3,779,607 A	12/1973	Staab

4,040,668 A	8/1977	Fairweather
4,463,989 A	8/1984	Kennedy
4,690,691 A	9/1987	Komanduri
4,702,649 A	10/1987	Komanduri
4,714,385 A	12/1987	Komanduri
4,797,138 A	1/1989	Komanduri
D317,010 S	5/1991	Knemeyer
5,083,839 A	1/1992	Younger
5,127,588 A	7/1992	Schmidt

(Continued)

**FOREIGN PATENT DOCUMENTS**

CN 102296522 12/2011

**OTHER PUBLICATIONS**

Written Opinion of the International Searching Authority dated Feb. 14, 2019 for corresponding International Application No. PCT/US18/62259.

(Continued)

*Primary Examiner* — Michael C Stout

*Assistant Examiner* — Fritzgerald L Butac

(74) *Attorney, Agent, or Firm* — Walter Haverfield LLP

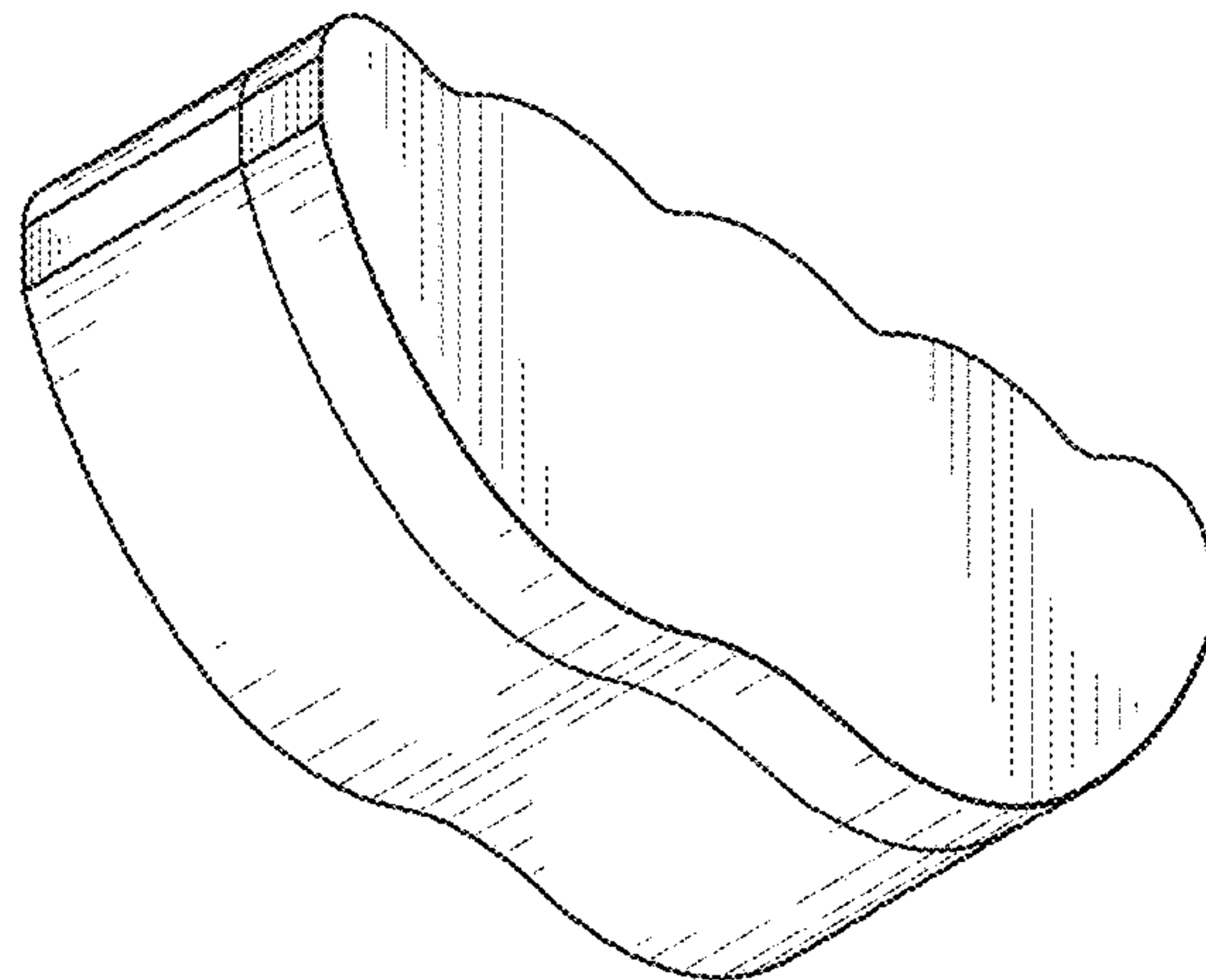
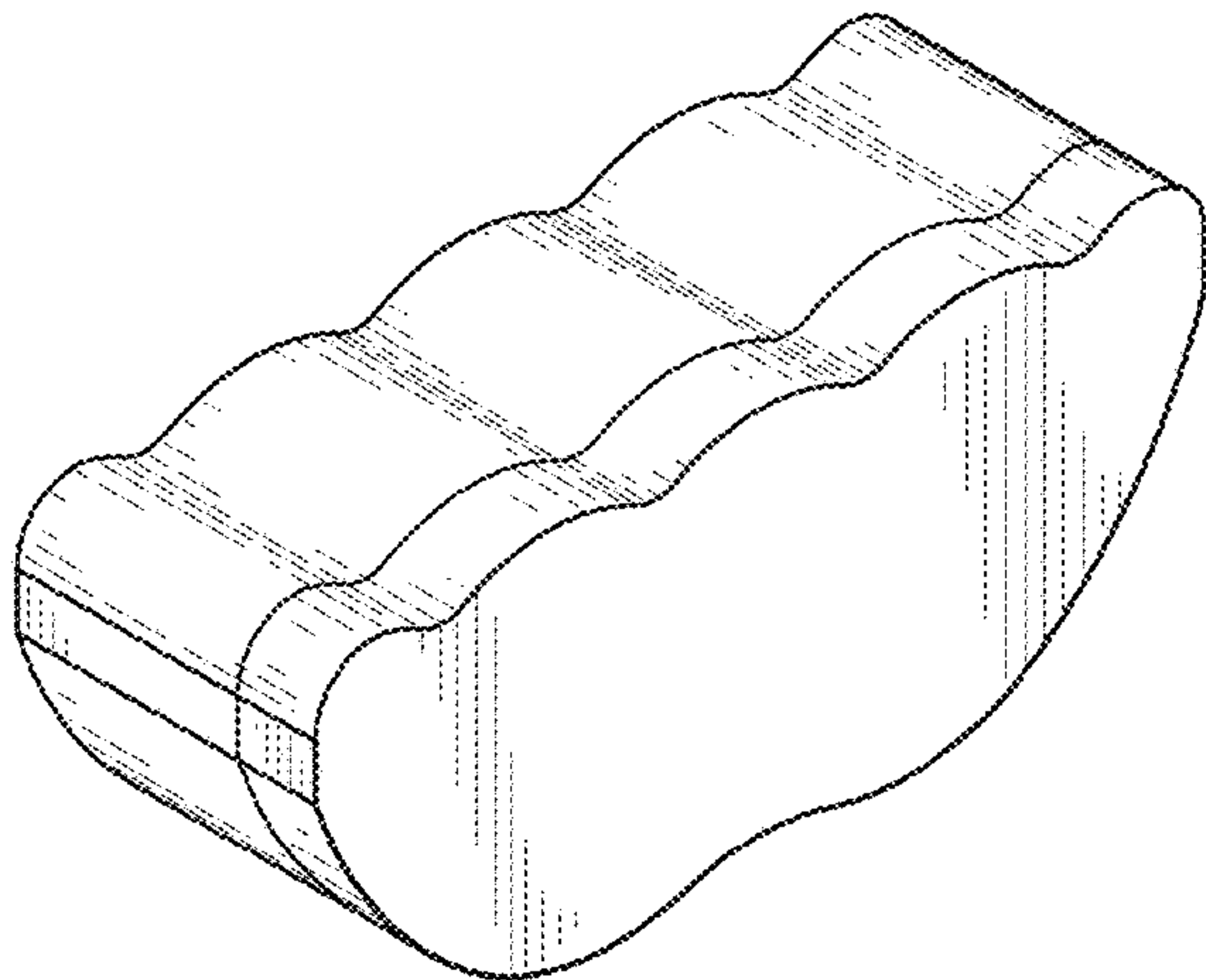
(57) **CLAIM**

The ornamental design for a cutter head for grinding machines and the like, as shown and described.

**DESCRIPTION**

FIG. 1 is a front perspective view of a cutter head for grinding machines and the like;  
FIG. 2 is another perspective view thereof;  
FIG. 3 is a front view, with the rear view being a mirror image thereof;  
FIG. 4 is a top view thereof;  
FIG. 5 is a bottom view thereof; and,  
FIG. 6 is a left side view, with the right side being a mirror image thereof.

**1 Claim, 1 Drawing Sheet**



(56)

References Cited

U.S. PATENT DOCUMENTS

D330,206 S 10/1992 Slutz  
 5,271,696 A 12/1993 Stock  
 D357,485 S 4/1995 Mattsson et al.  
 5,464,163 A 11/1995 Zoz  
 5,733,074 A 3/1998 Stock et al.  
 6,390,086 B1 5/2002 Collins  
 6,450,738 B1 9/2002 Ripley  
 D502,952 S 3/2005 Achilles et al.  
 7,223,049 B2 5/2007 Hall et al.  
 D554,162 S 10/2007 Hall et al.  
 7,287,818 B1 10/2007 Hall et al.  
 D558,241 S 12/2007 Chiang  
 D558,242 S 12/2007 Chiang  
 7,320,505 B1 1/2008 Hall et al.  
 7,384,105 B2 6/2008 Hall et al.  
 7,387,464 B2 6/2008 Hall et al.  
 7,396,085 B2 7/2008 Hall et al.  
 7,445,294 B2 11/2008 Hall et al.  
 7,469,972 B2 12/2008 Hall et al.  
 D595,322 S \* 6/2009 Sakata ..... D15/139  
 D595,323 S \* 6/2009 Sakata ..... D15/139  
 7,553,344 B2 6/2009 Cho  
 D595,751 S \* 7/2009 Sakata ..... D15/139  
 7,588,102 B2 9/2009 Hall et al.  
 7,665,552 B2 2/2010 Hall et al.  
 7,926,597 B2 4/2011 Majagi et al.  
 8,365,845 B2 2/2013 Hall et al.  
 8,590,643 B2 11/2013 Smallman et al.  
 8,960,337 B2 2/2015 Hall et al.  
 D809,031 S \* 1/2018 Burton ..... B28D 1/186  
 D815,165 S \* 4/2018 Morisaki ..... D15/139  
 D826,664 S \* 8/2018 Matsubara ..... D15/139  
 10,239,184 B2 3/2019 Axnite  
 D854,592 S \* 7/2019 Matsuda ..... D15/139  
 D872,145 S \* 1/2020 Maeno ..... D15/139  
 D872,780 S \* 1/2020 Sato ..... D15/126  
 10,525,538 B2 \* 1/2020 Matsuda ..... B23C 5/10  
 D875,147 S \* 2/2020 Xu ..... D15/139  
 D879,846 S \* 3/2020 Sato ..... D15/126  
 D879,847 S \* 3/2020 Sato ..... D15/126  
 D879,848 S \* 3/2020 Kinoshita ..... D15/139  
 10,632,547 B2 \* 4/2020 Morisaki ..... B23C 5/20  
 D883,350 S \* 5/2020 Toldo ..... D15/139  
 D884,039 S \* 5/2020 Endoh ..... D15/139  
 D884,040 S \* 5/2020 Endoh ..... D15/139  
 D890,234 S \* 7/2020 Maeno ..... D15/139  
 D890,235 S \* 7/2020 Maeno ..... D15/139  
 D890,827 S \* 7/2020 Maeno ..... D15/139  
 D891,490 S \* 7/2020 Maeno ..... D15/139  
 10,717,136 B2 \* 7/2020 Shimanuki ..... B23B 27/148

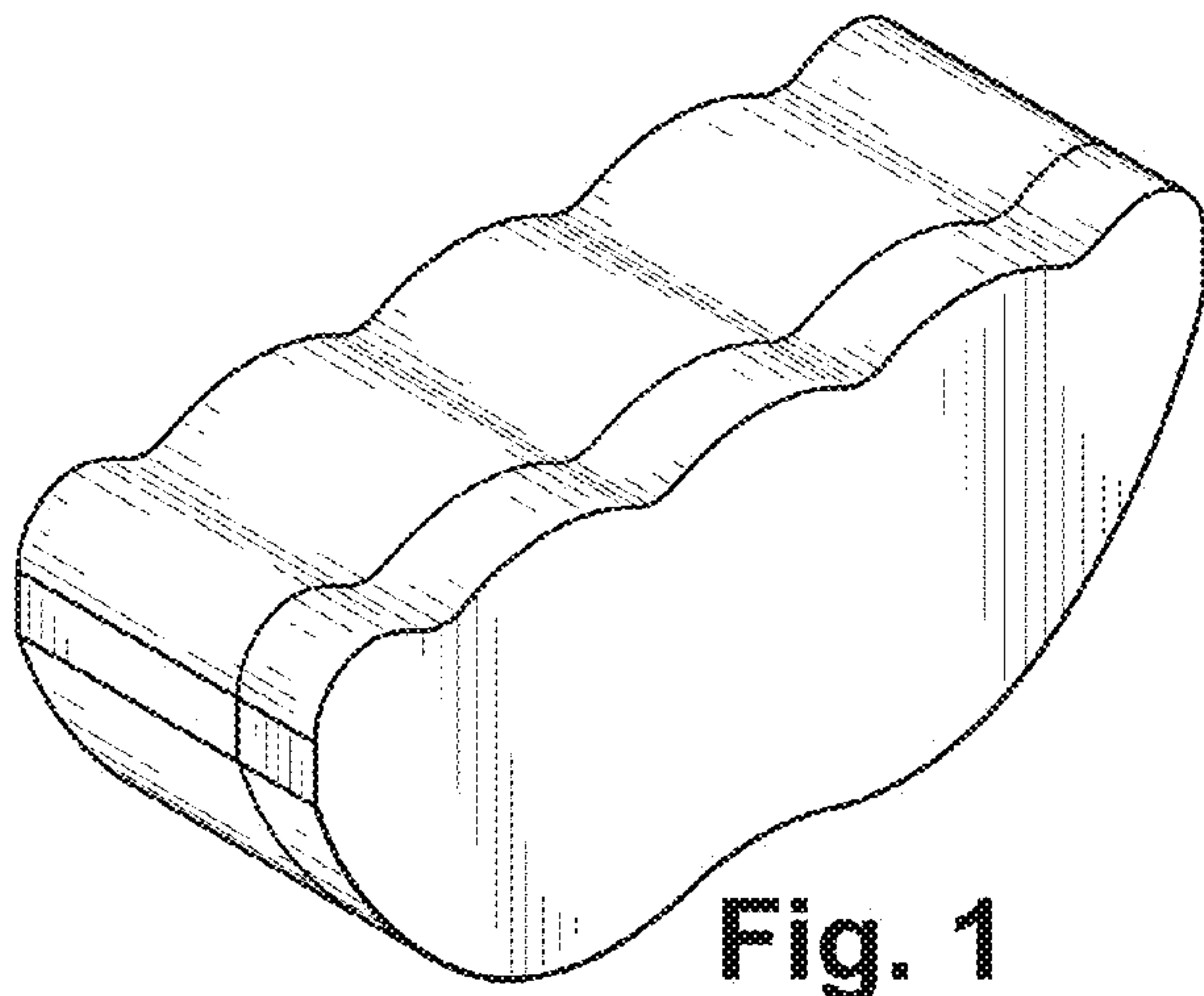
D892,876 S \* 8/2020 Matsubara ..... D15/139  
 D902,268 S \* 11/2020 Sueyoshi ..... D15/139  
 10,875,105 B2 \* 12/2020 Koike ..... B23C 5/06  
 10,875,106 B2 \* 12/2020 Tsujimoto ..... B23C 5/06  
 D909,437 S \* 2/2021 Sorai ..... D15/139  
 D910,093 S \* 2/2021 Abe ..... D15/139  
 D910,095 S \* 2/2021 Wen ..... D15/139  
 D911,399 S \* 2/2021 Atkins ..... D15/139  
 2003/0062760 A1 4/2003 Wyser  
 2003/0155155 A1 8/2003 Dewey  
 2005/0040263 A1 2/2005 Parke  
 2005/0164620 A1 7/2005 Amamoto  
 2007/0192112 A1 8/2007 Hall  
 2008/0009232 A1 1/2008 Thysell  
 2008/0250724 A1 10/2008 Hall et al.  
 2010/0242375 A1 9/2010 Hall et al.  
 2010/0244545 A1 9/2010 Hall et al.  
 2010/0299285 A1 11/2010 Hall  
 2010/0326740 A1 12/2010 Hall et al.  
 2011/0020163 A1 1/2011 Nilen  
 2011/0226532 A1 9/2011 Jonker et al.  
 2011/0283628 A1 11/2011 Saridikmen et al.  
 2012/0012229 A1 1/2012 Kappel  
 2012/0247028 A1 1/2012 Konyashin et al.  
 2012/0037429 A1 2/2012 Davies et al.  
 2012/0037430 A1 2/2012 Smallman  
 2012/0040157 A1 2/2012 Konyashin et al.  
 2012/0055717 A1 3/2012 Liversage et al.  
 2012/0061149 A1 3/2012 Liversage et al.  
 2012/0177453 A1 7/2012 Konyashin et al.  
 2012/0304547 A1 12/2012 Anagnostaras  
 2013/0000993 A1 1/2013 Shabalala et al.  
 2013/0213721 A1 8/2013 Nilen et al.  
 2014/0110991 A1 4/2014 Sollami  
 2014/0115974 A1 5/2014 Konyashin et al.  
 2014/0165476 A1 6/2014 Can et al.  
 2014/0198827 A1 7/2014 Liversage  
 2014/0284115 A1 9/2014 Can et al.  
 2014/0339879 A1 11/2014 Burton et al.  
 2014/0339882 A1 11/2014 Hall et al.  
 2014/0339883 A1 11/2014 Burton et al.  
 2015/0016884 A1 1/2015 Hall et al.  
 2015/0041225 A1 2/2015 Jonker et al.  
 2016/0237631 A1 8/2016 Nishida  
 2019/0276993 A1 9/2019 Sewell

OTHER PUBLICATIONS

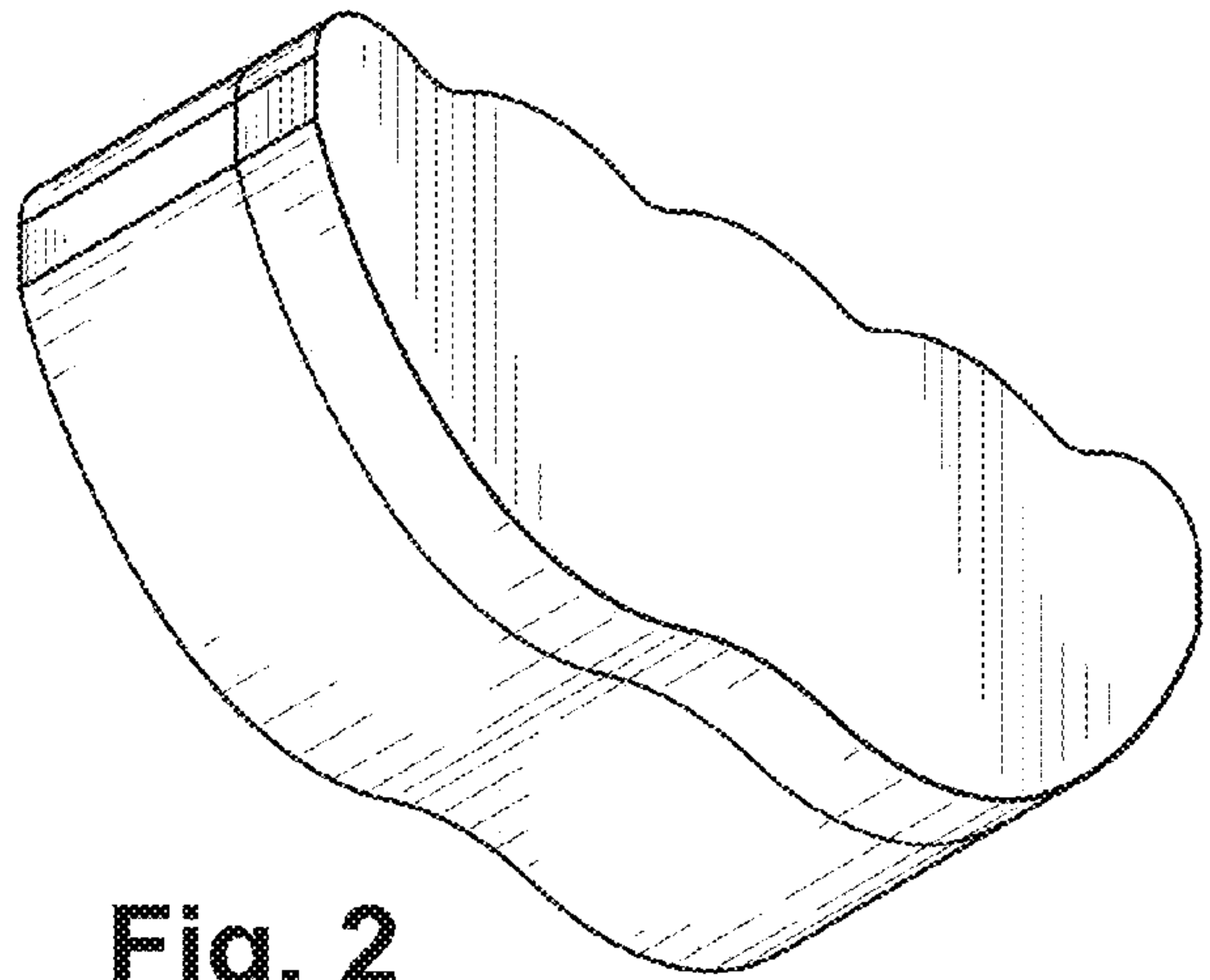
International Search Report from the ISA/US dated Feb. 14, 2019 for corresponding International Application No. PCT/US18/62259. International Preliminary Report on Patentability from The International Bureau of WIPO dated Jun. 2, 2020 for corresponding International Application No. PCT/US2018/062259.

\* cited by examiner

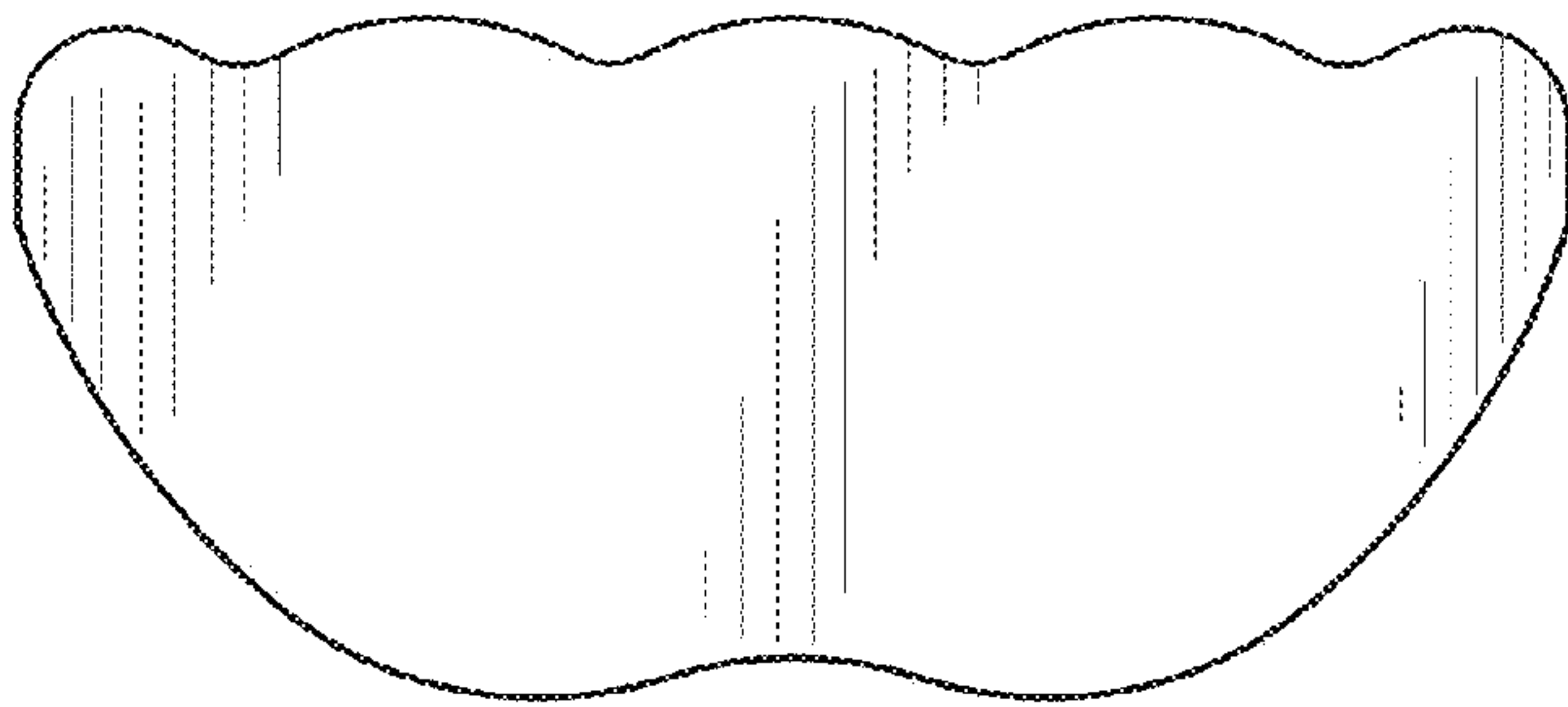




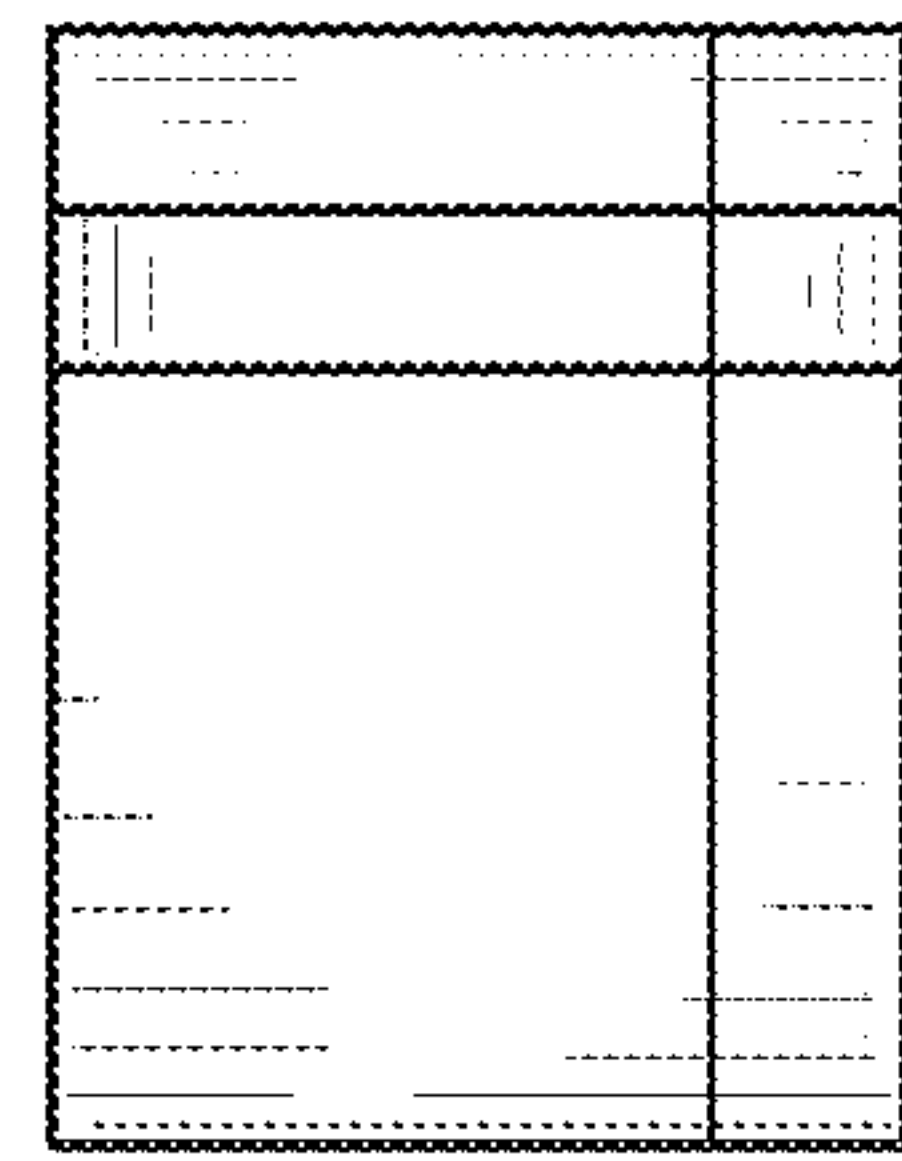
**Fig. 1**



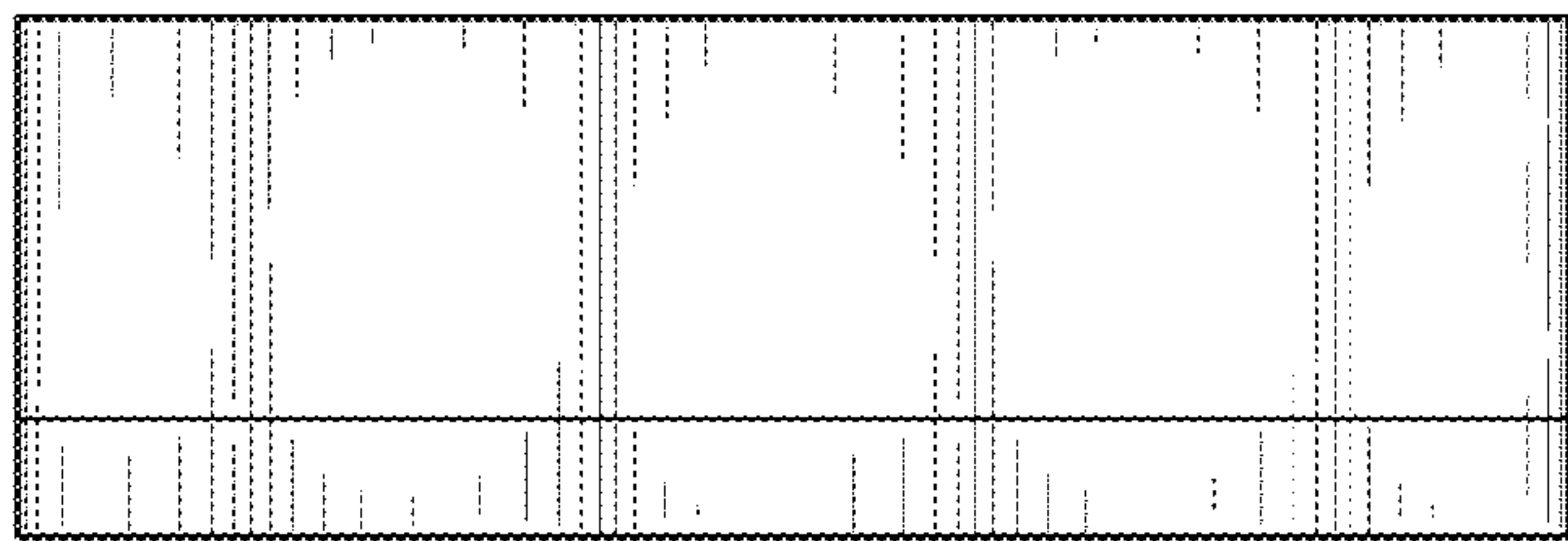
**Fig. 2**



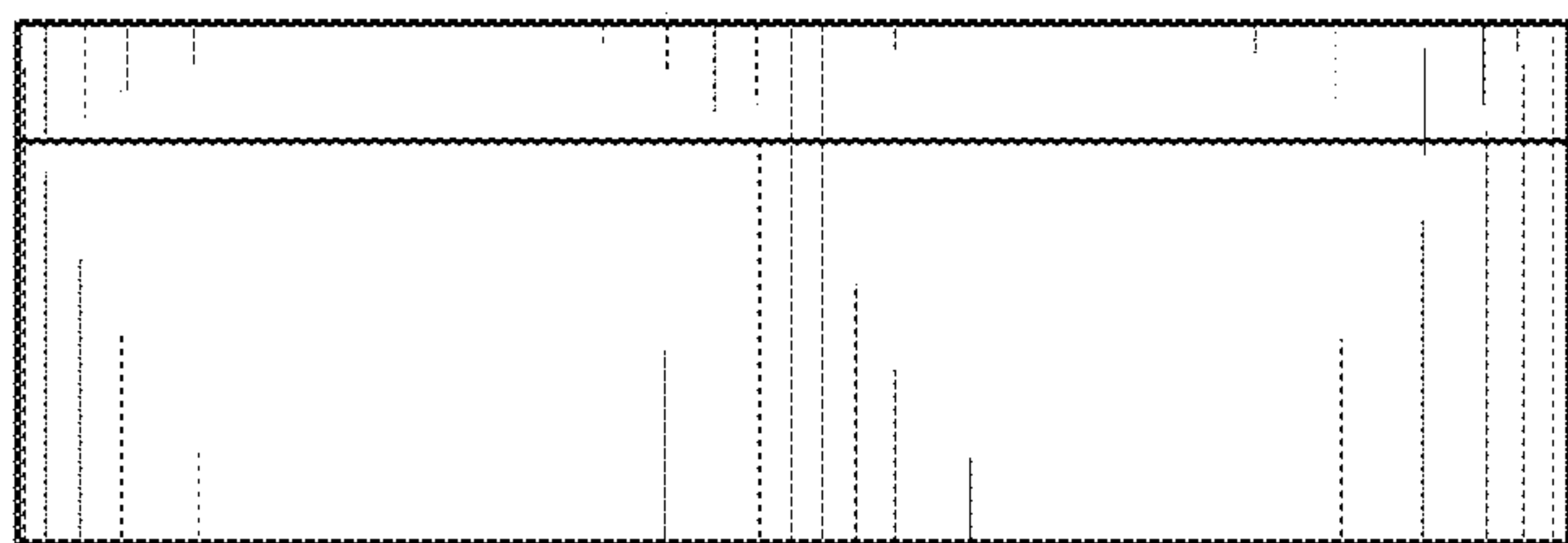
**Fig. 3**



**Fig. 6**



**Fig. 4**



**Fig. 5**