



US00D960218S

(12) **United States Design Patent** (10) **Patent No.:** **US D960,218 S**  
**Smith** (45) **Date of Patent:** **\*\* Aug. 9, 2022**

(54) **APPARATUS FOR PROVIDING BROADBAND LIGHT**

(71) Applicant: **NKT Photonics A/S**, Birkerød (DK)

(72) Inventor: **Johannes Anders Smith**, Hellerup (DK)

(\*\*) Term: **15 Years**

(21) Appl. No.: **29/782,604**

(22) Filed: **May 7, 2021**

**Related U.S. Application Data**

(62) Division of application No. 35/508,838, filed on Jan. 31, 2020 (U.S. filing date under 35 U.S.C. 384), and having an international filing date of Jan. 31, 2020.

(51) **LOC (13) Cl.** ..... **16-99**

(52) **U.S. Cl.**  
USPC ..... **D16/130**

(58) **Field of Classification Search**  
USPC ..... D23/366; D26/51, 60, 72, 113; D3/263, D3/265, 266; D24/209, 210, 231; D14/204, 214, 215; D16/130; D10/78  
CPC ..... H01S 3/302; G01N 2201/06113  
See application file for complete search history.

(56) **References Cited**

**U.S. PATENT DOCUMENTS**

D342,522 S \* 12/1993 Kurachi ..... D14/213  
D497,897 S \* 11/2004 Modschiedler ..... D14/172  
D617,313 S \* 6/2010 Iseki ..... D14/214  
D718,275 S \* 11/2014 Shim ..... D14/214  
D755,755 S \* 5/2016 Hewitt ..... D14/214

D757,955 S \* 5/2016 Johnson ..... D24/209  
D771,018 S \* 11/2016 Espinosa ..... D14/214  
D796,837 S \* 9/2017 Wu  
D800,095 S \* 10/2017 Yao ..... D14/214  
D815,618 S \* 4/2018 Choi ..... D14/214  
D853,008 S \* 7/2019 Joyeux ..... D26/72  
D877,497 S \* 3/2020 Stevens  
D881,845 S \* 4/2020 Warnhammar ..... D14/214  
D913,987 S \* 3/2021 Li ..... D14/204  
D922,352 S \* 6/2021 Byrd ..... D14/214

\* cited by examiner

*Primary Examiner* — Calvin E Vansant

(74) *Attorney, Agent, or Firm* — Buchanan Ingersoll & Rooney PC

(57) **CLAIM**

The ornamental design for an apparatus for providing broadband light, as shown and described.

**DESCRIPTION**

FIG. 1 is a top front left perspective view of an apparatus for providing broadband light showing my new design.  
FIG. 2 is a top rear left perspective view thereof.  
FIG. 3 is a front side elevational view thereof.  
FIG. 4 is a rear side elevational view thereof.  
FIG. 5 is a left side elevational view thereof.  
FIG. 6 is a right side elevational view thereof; and,  
FIG. 7 is a top plan view thereof.  
The broken line illustrations in FIGS. 1-6 show an environmental structure and are not part of the claimed design, and the dot-dashed line illustrations in FIGS. 1, 2, 3 and 7 define bounds of the claimed design and form no part thereof.

**1 Claim, 7 Drawing Sheets**

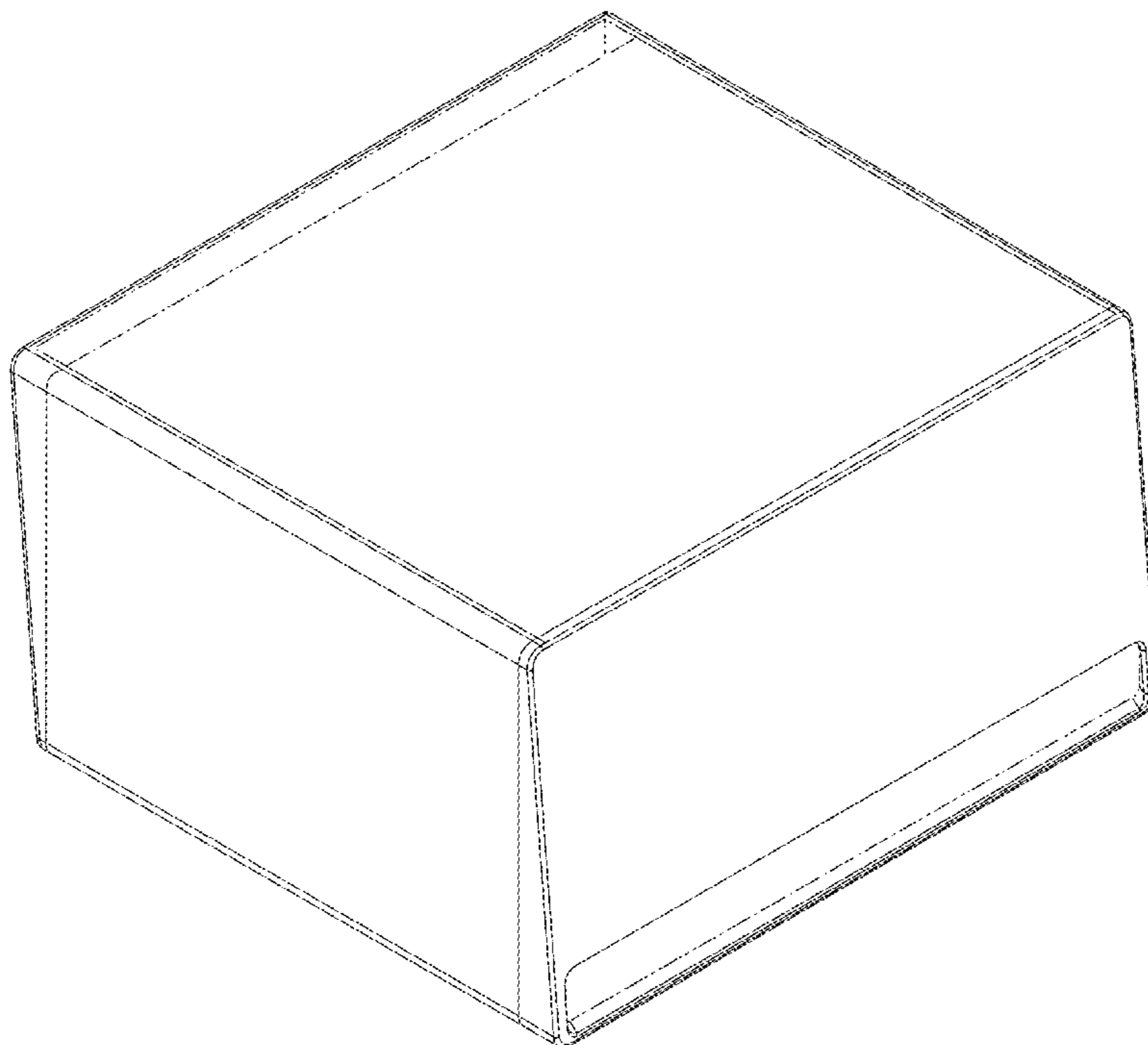

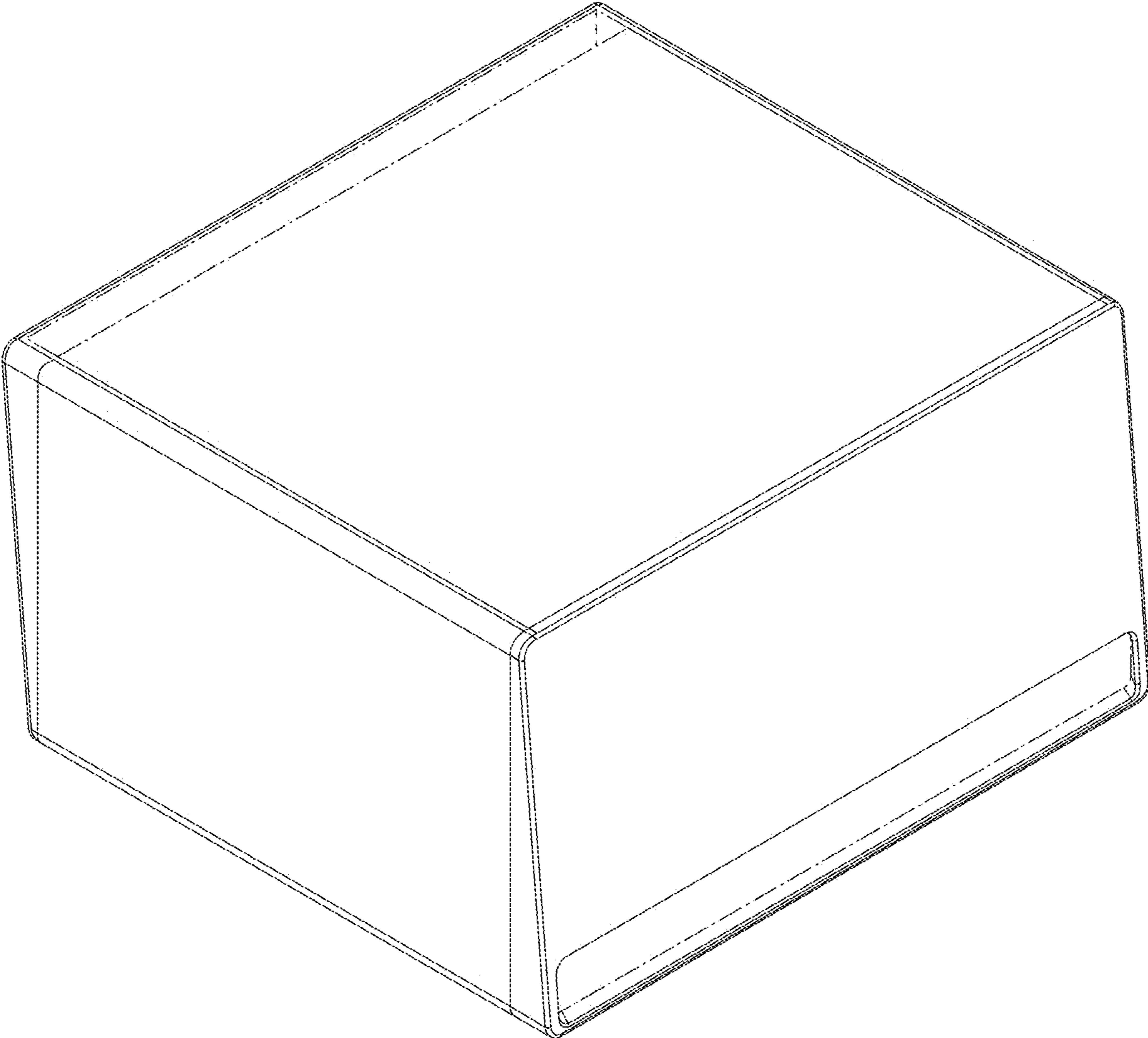

FIG. 1

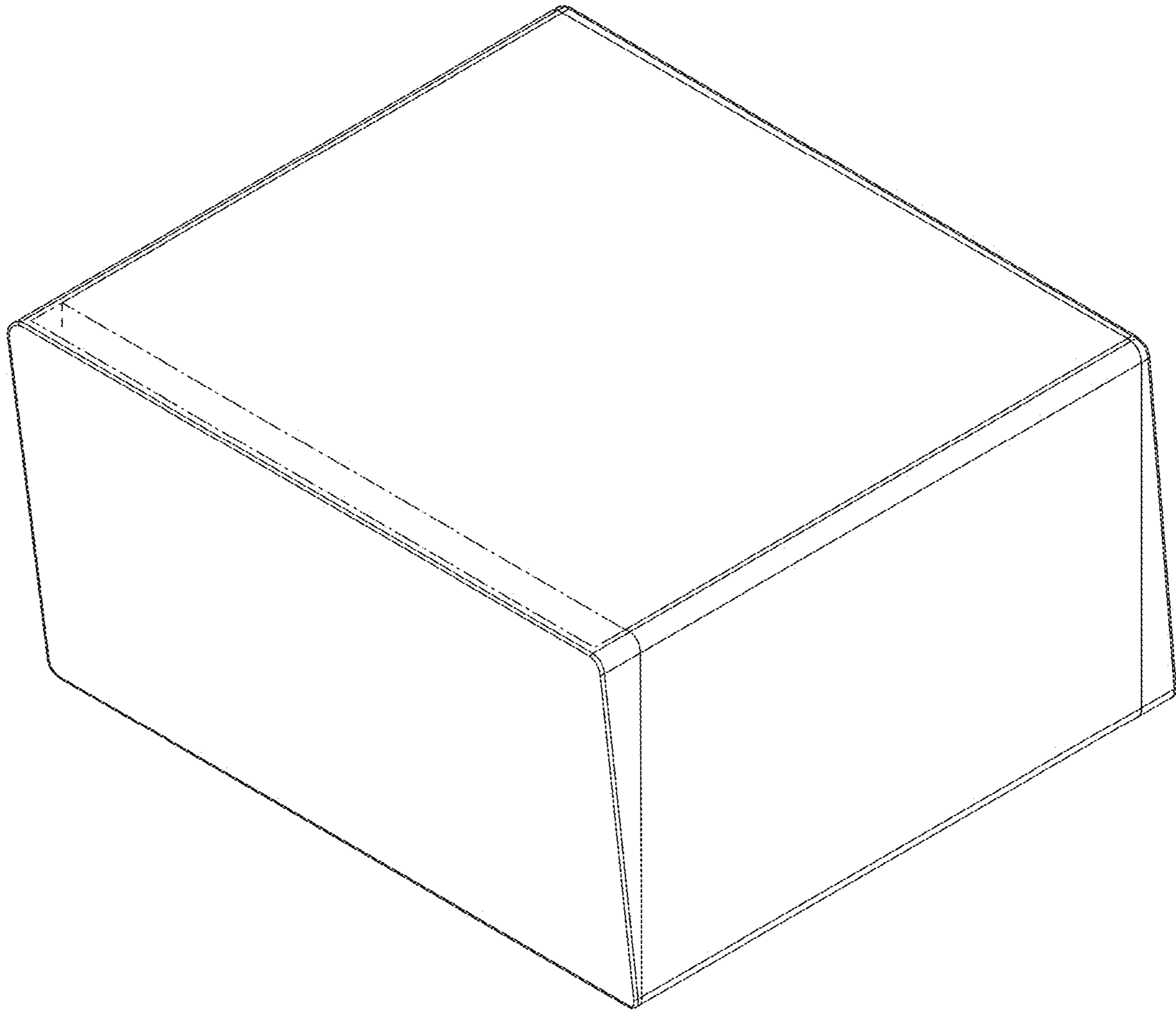

FIG. 2

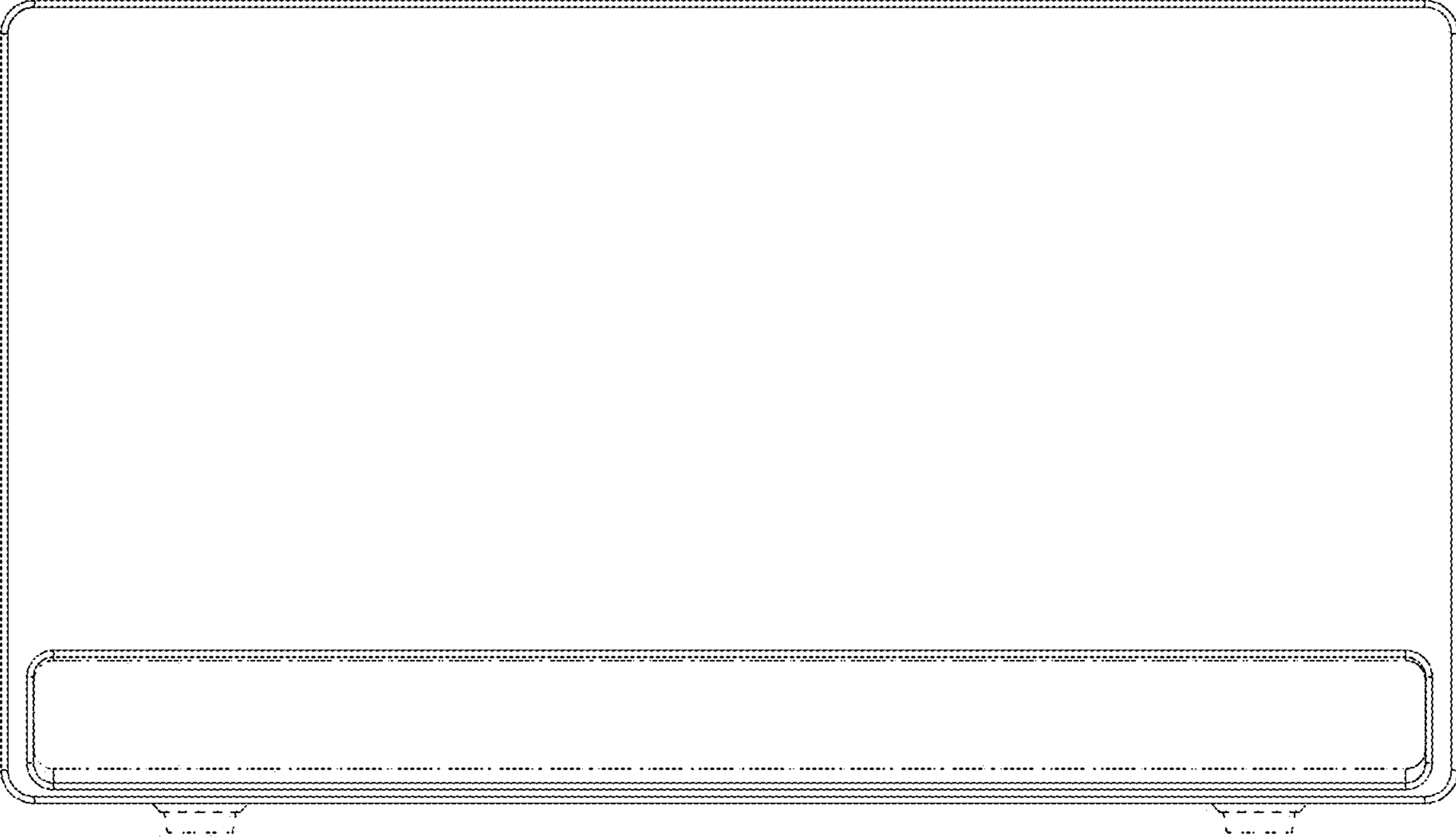

FIG. 3



FIG. 4

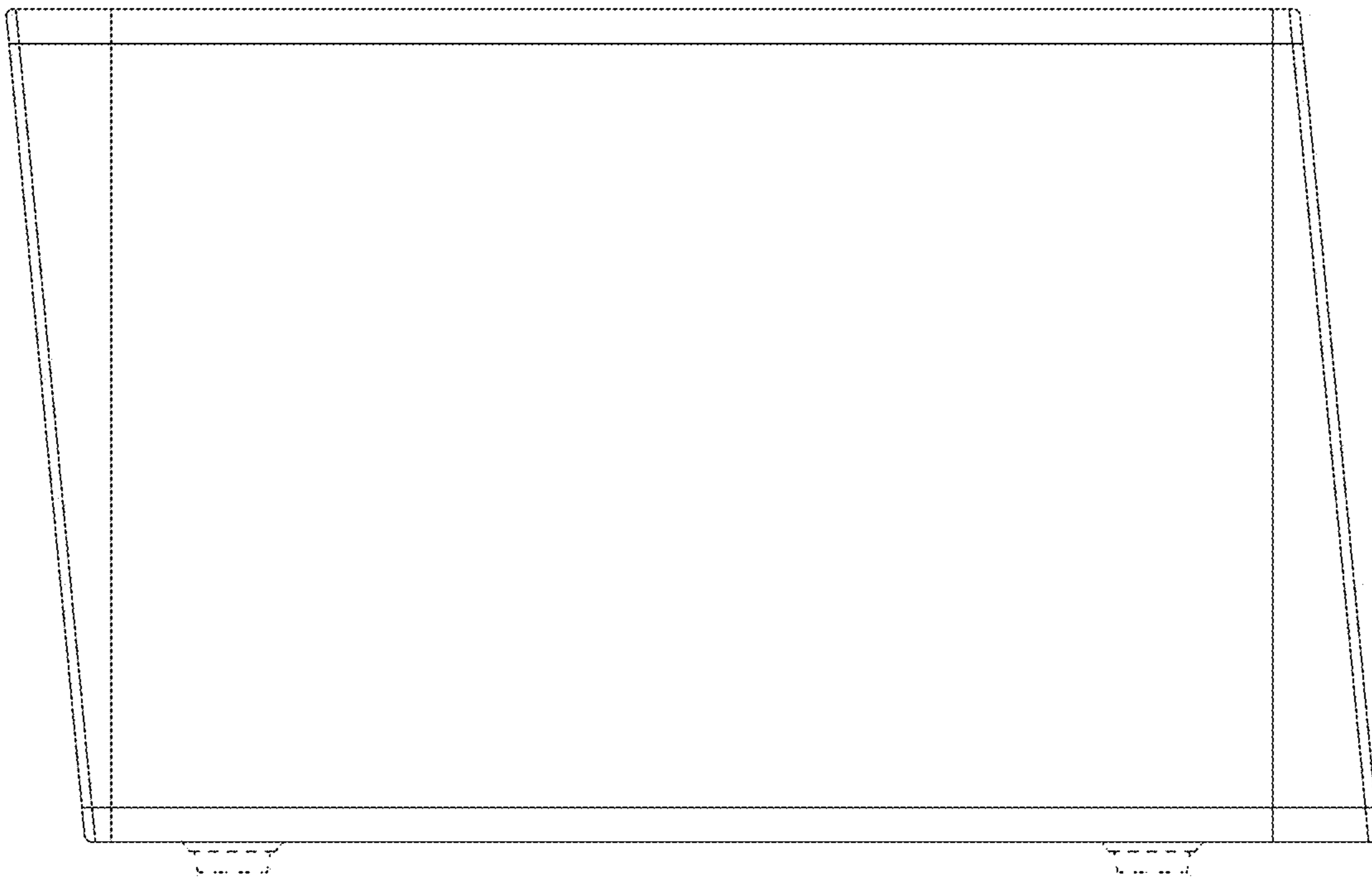

FIG. 5

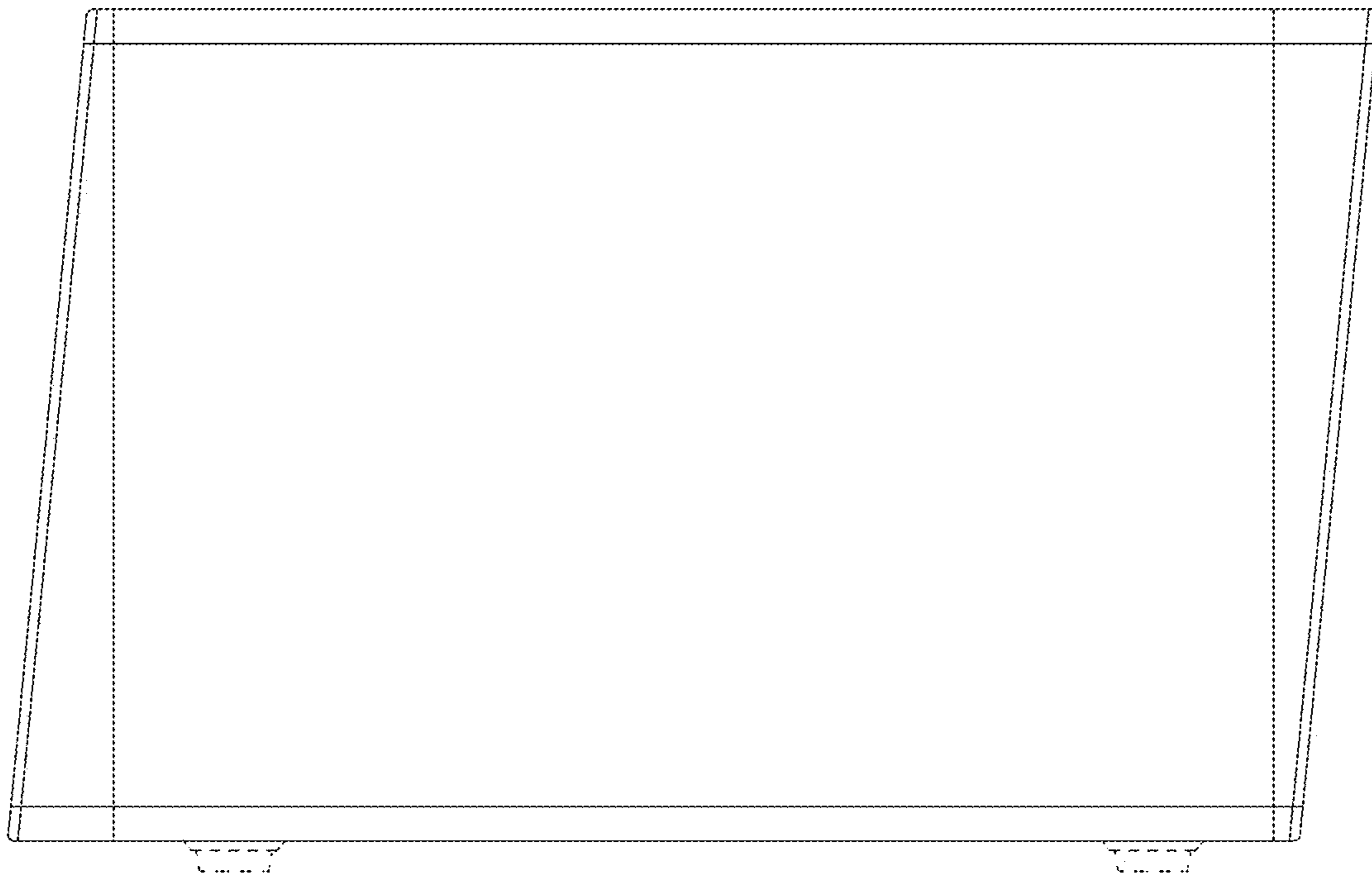

FIG. 6



FIG. 7