



US00D959562S

(12) **United States Design Patent** (10) **Patent No.:** **US D959,562 S**
Edwards et al. (45) **Date of Patent:** **** Aug. 2, 2022**

(54) **GAMING SYSTEM**
(71) Applicant: **IGT, Las Vegas, NV (US)**
(72) Inventors: **Douglas Edwards, Henderson, NV (US); Theodore J. Swanson, Henderson, NV (US)**
(73) Assignee: **IGT, Las Vegas, NV (US)**
(**) Term: **15 Years**
(21) Appl. No.: **29/731,766**
(22) Filed: **Apr. 17, 2020**
(51) **LOC (13) Cl.** **21-03**
(52) **U.S. Cl.**
USPC **D21/370**
(58) **Field of Classification Search**
USPC D21/325, 329, 369-371, 374, 385;
D14/125, 218, 307, 371; D7/624.2;
D99/28
CPC .. G07F 17/3213; G07F 17/34; G07F 17/3211;
G07F 17/3244; G07F 17/3227; G07F
17/3209
See application file for complete search history.

D826,003 S * 8/2018 Seiders D7/624.2
D827,598 S * 9/2018 Kwon D14/125
D845,258 S * 4/2019 D'Ambrosio D14/125
10,275,992 B2 4/2019 Carpenter et al.
D850,054 S * 5/2019 Del Vecchio D99/28
D858,642 S 9/2019 Legras et al.
D859,335 S * 9/2019 D'Ambrosio D14/125
D873,821 S * 1/2020 Song D14/371
(Continued)

OTHER PUBLICATIONS

DIMENSION 27, Three stacked 27-inch displays in 4K Ultra HD, first available Nov. 4, 2021, konami.com [online], site visited Nov. 10, 2021], Available from internet URL: <https://www.konami.com/corporate/en/business/gaming.html> (Year: 2021).*

(Continued)

Primary Examiner — Garth Rademaker
Assistant Examiner — Salamah Jordan
(74) *Attorney, Agent, or Firm* — Neal, Gerber & Eisenberg LLP

(57) **CLAIM**

The ornamental design for a gaming system, as shown and described.

DESCRIPTION

FIG. 1 is at front perspective view of a gaming system showing our new design.
FIG. 2 is a front view of the gaming system of FIG. 1.
FIG. 3 is a rear view of the gaming system of FIG. 1.
FIG. 4 is a right side view of the gaming system of FIG. 1.
FIG. 5 is a left side view of the gaming system of FIG. 1.
FIG. 6 is a top view of the gaming system of FIG. 1; and, FIG. 7 is a bottom view of the gaming system of FIG. 1.
The broken lines in the figures illustrate portions of the gaming system that form no part of the claimed design.

1 Claim, 7 Drawing Sheets

(56) **References Cited**

U.S. PATENT DOCUMENTS

D536,388 S 2/2007 Kaminkow et al.
D548,800 S 8/2007 Kaminkow et al.
D559,917 S 1/2008 Cole
D605,231 S 12/2009 Hashimoto et al.
8,216,065 B2 7/2012 Kaminkow et al.
D697,558 S 1/2014 Myers et al.
D721,767 S 1/2015 Ferrazoli
D726,161 S * 4/2015 Howard D14/218
D740,887 S 10/2015 Randazzo
D763,210 S * 8/2016 Park D14/125
9,679,435 B2 6/2017 Schrementi et al.
D818,048 S 5/2018 Calhoun et al.

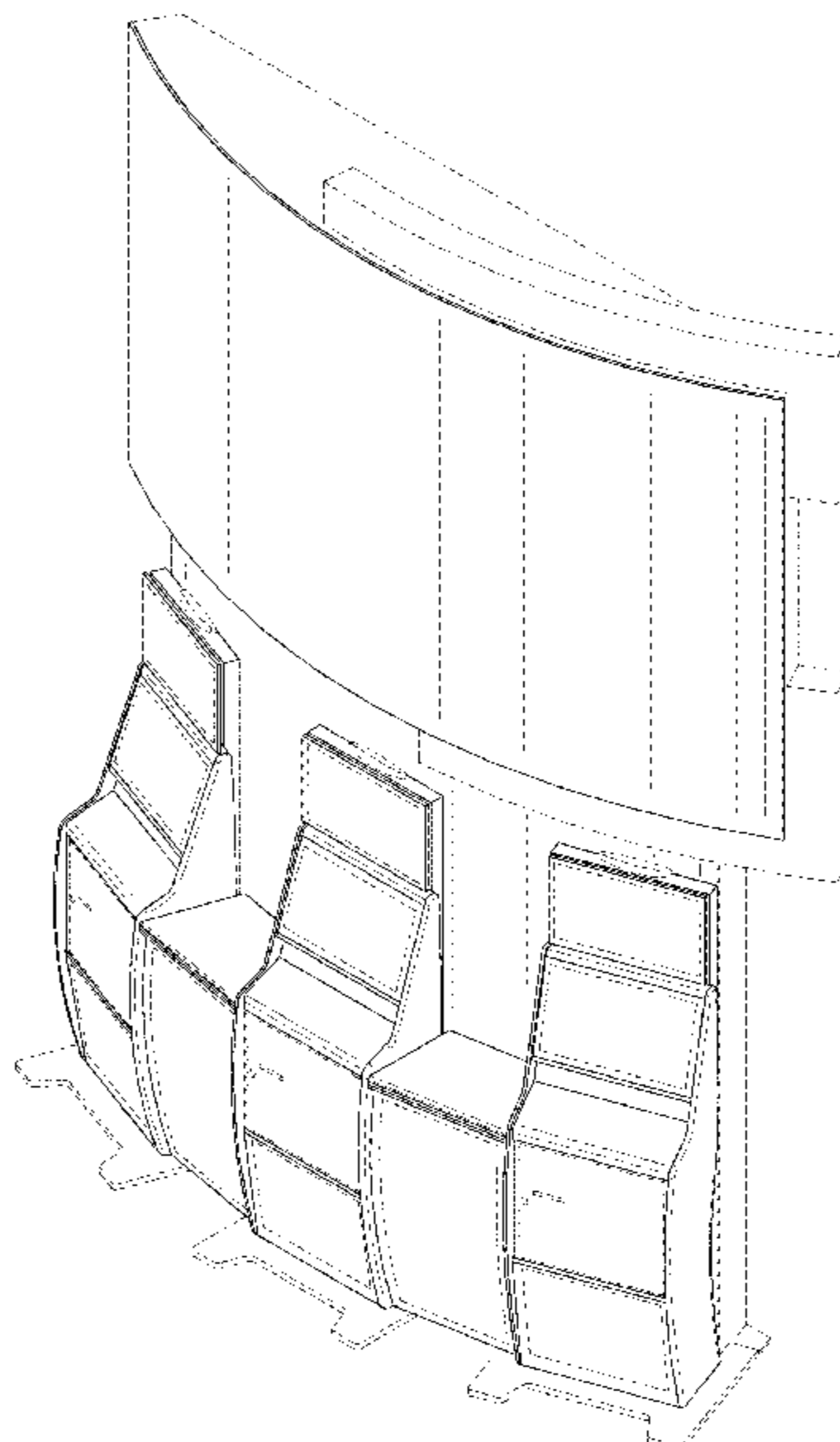

(56)

References Cited

U.S. PATENT DOCUMENTS

D878,477	S	3/2020	Bernard et al.	
D880,605	S *	4/2020	Bussey	D21/369
D883,393	S	5/2020	Bernard et al.	
D888,159	S *	6/2020	Schoonmaker	D21/369
D891,520	S *	7/2020	Urban	D21/385
D893,628	S	8/2020	Thoeni et al.	
D893,632	S	8/2020	McGahn et al.	
D904,523	S	12/2020	Legras	
D926,259	S *	7/2021	Schoonmaker	D21/369
D934,236	S *	10/2021	Giacomin	D14/307
2006/0009283	A1	1/2006	Englman et al.	
2019/0102974	A1	4/2019	Bussey et al.	

OTHER PUBLICATIONS

“Dragon Link”, by Aristocrat, available prior to Apr. 17, 2020 (1 page).

“Fortune Link”, IGT Product Offerings NIGA 2019 (1 page).

“IGT Crystaldual 27 Gaming Machine”, Available prior to Apr. 17, 2020 (2 pages).

“Sphinx 4D”, By IGT, Available prior to Apr. 17, 2020 (1 page).

“Wave Revolution Dragon Spin”, By Bally, available prior to Apr. 17, 2020 (1 page).

* cited by examiner

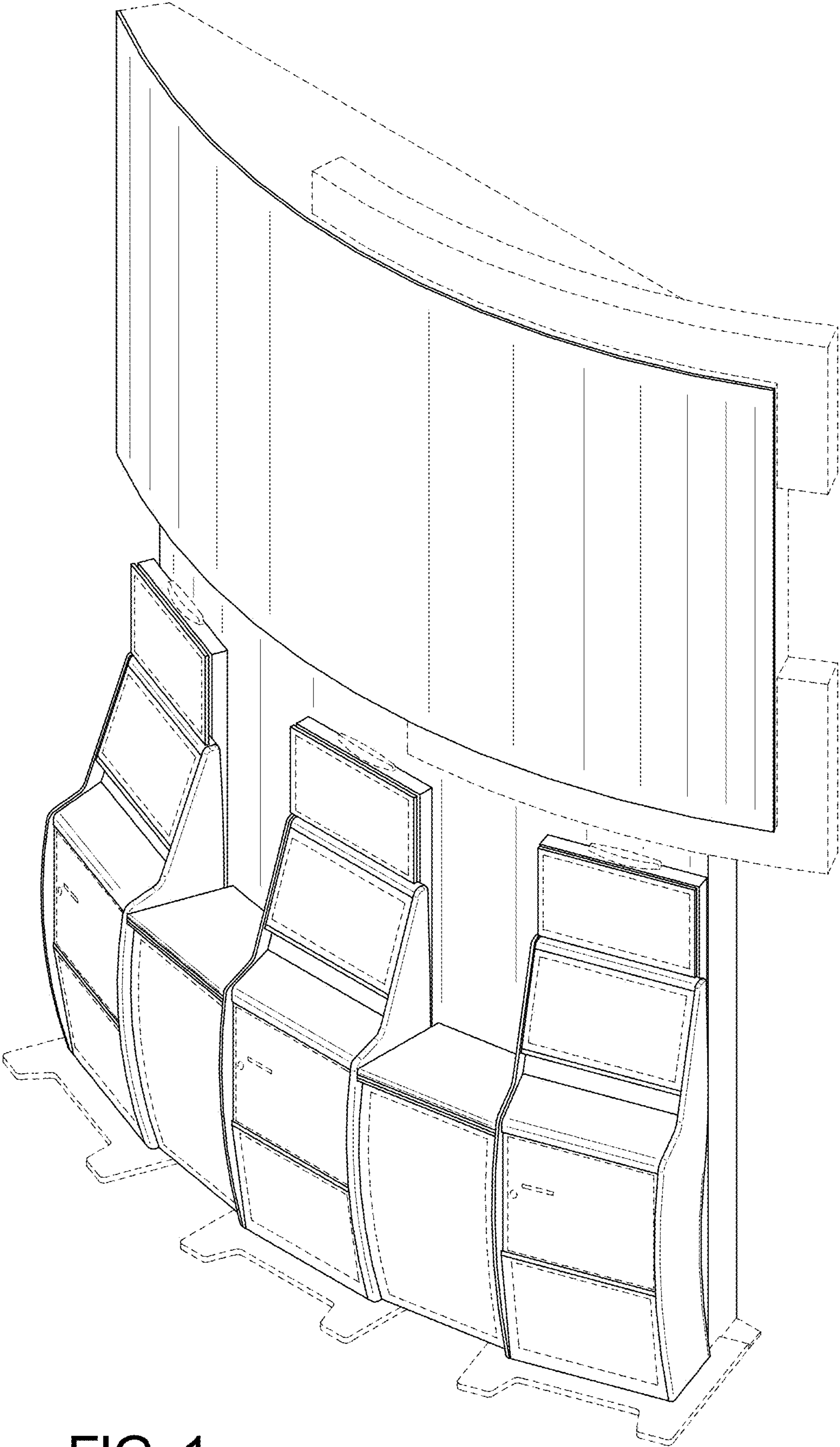

FIG. 1

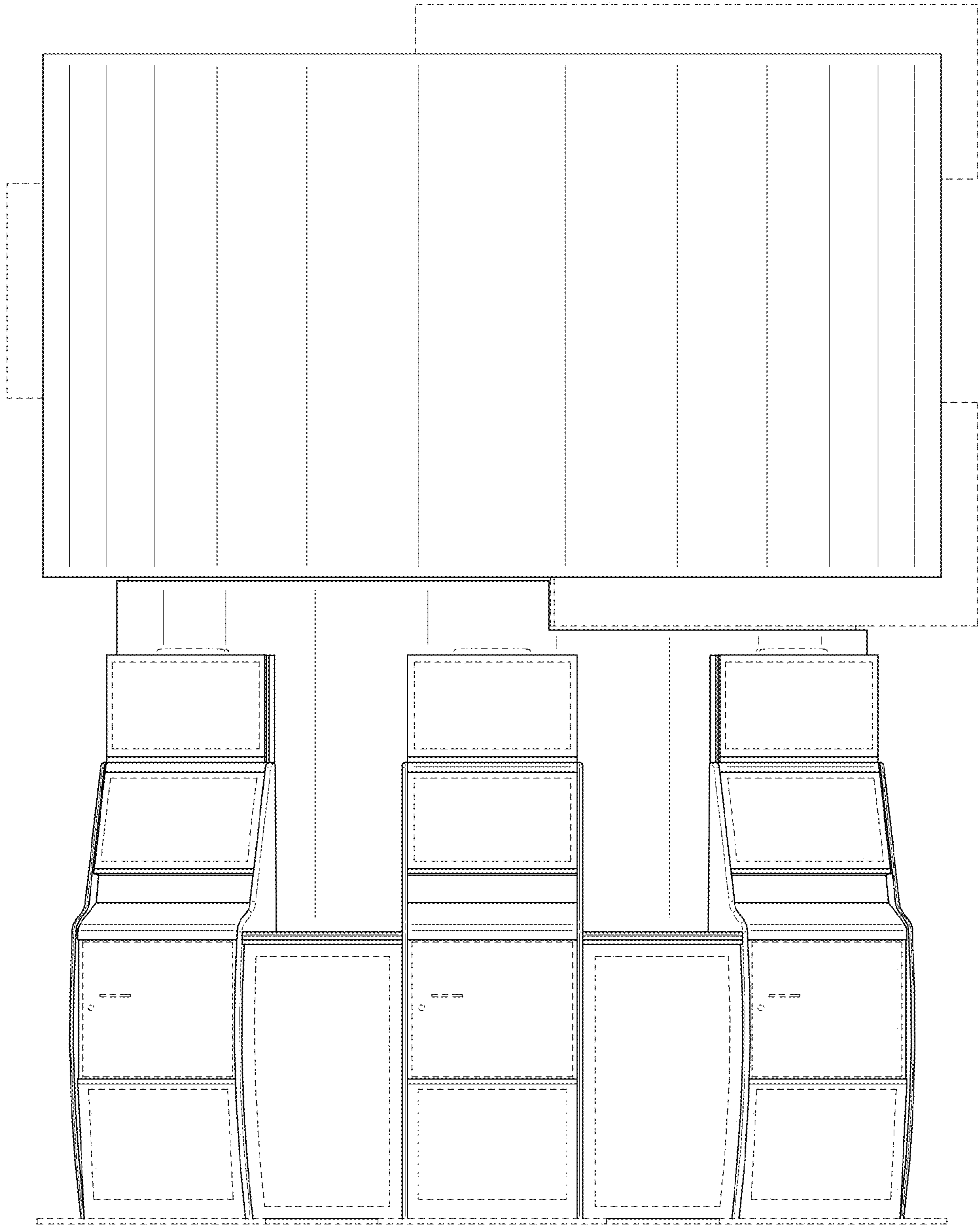

FIG. 2

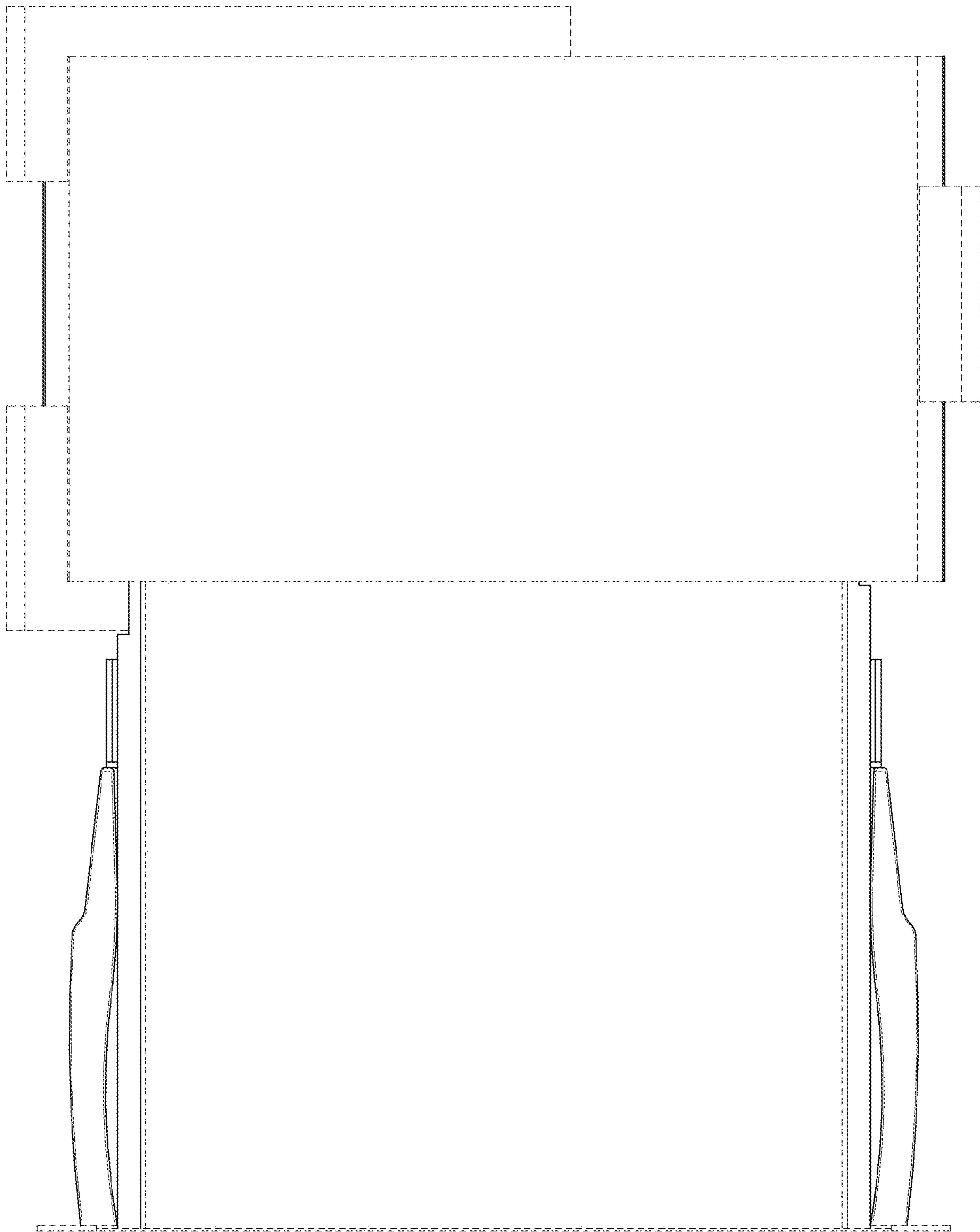

FIG. 3

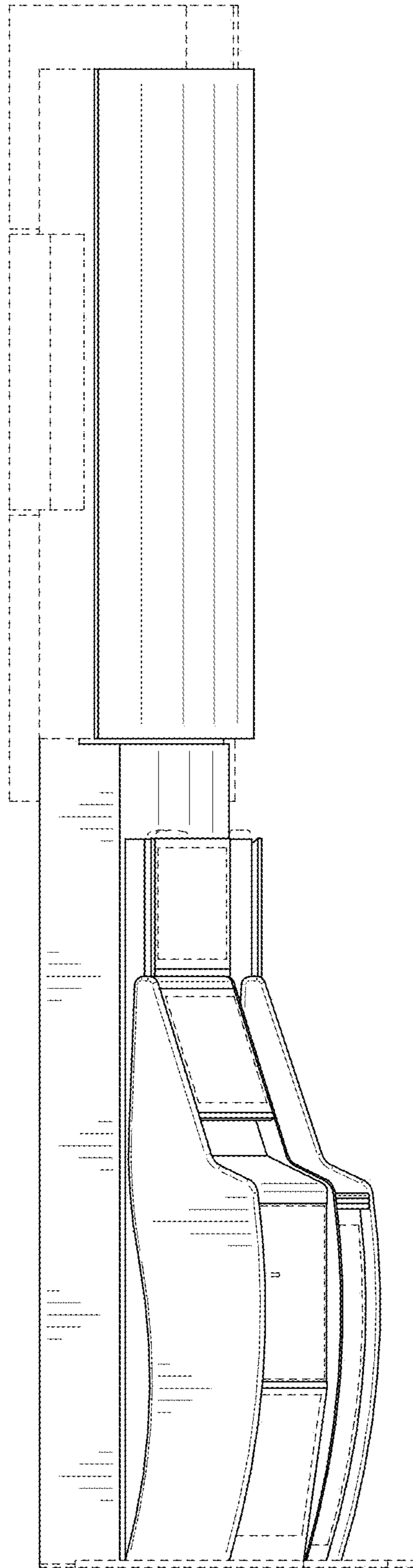

FIG. 4

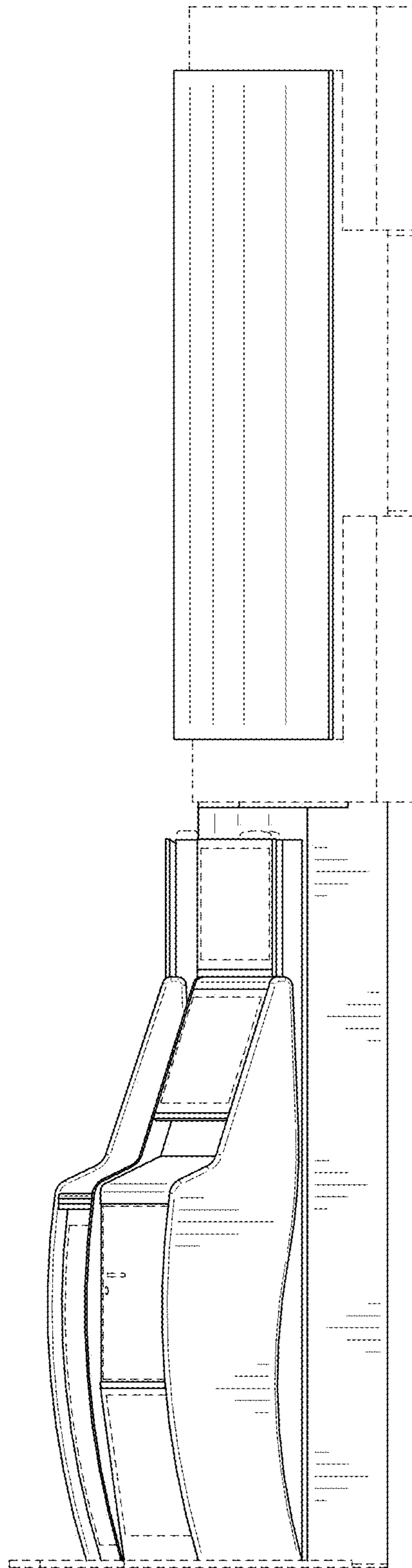

FIG. 5

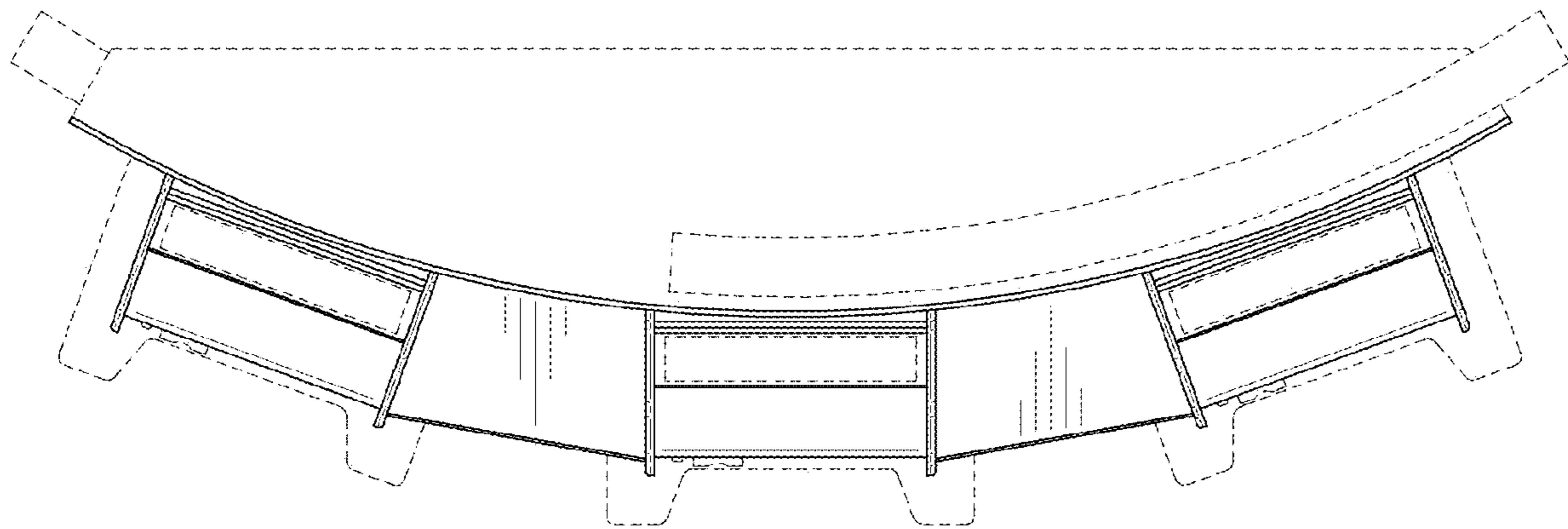

FIG. 6

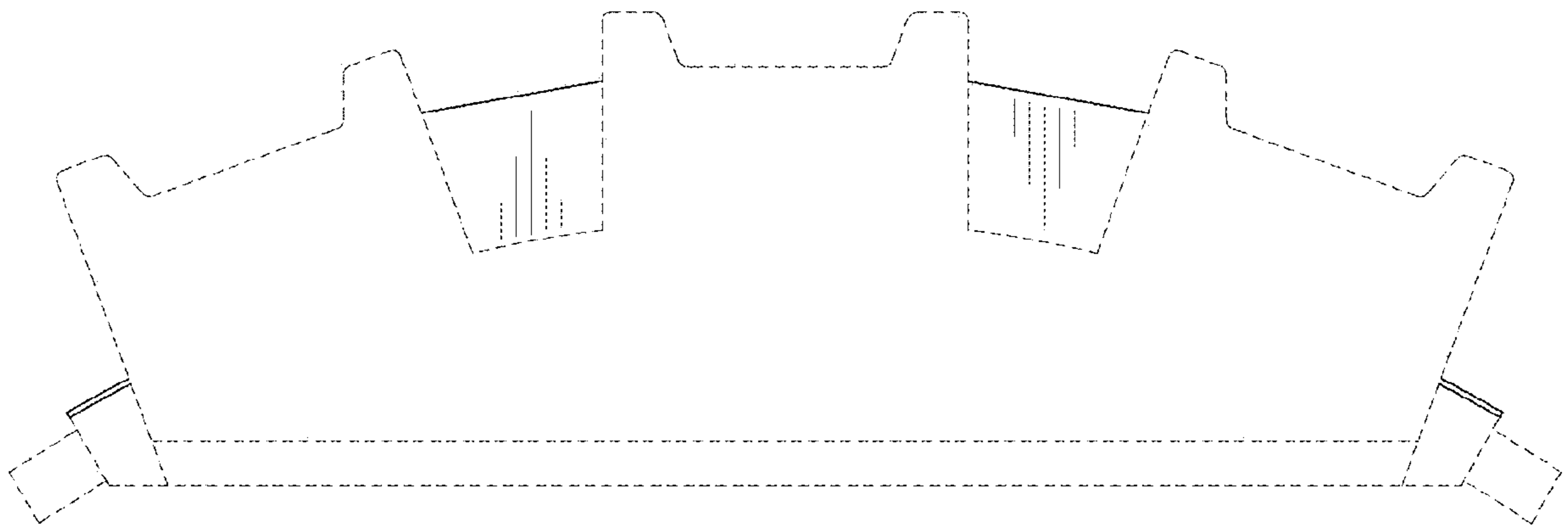

FIG. 7