



US00D959335S

(12) **United States Design Patent** (10) **Patent No.:** **US D959,335 S**
Giulianelli et al. (45) **Date of Patent:** **** Aug. 2, 2022**

(54) **MOTORCYCLE**
 (71) Applicant: **YAMAHA HATSUDOKI KABUSHIKI KAISHA**, Shizuoka-ken (JP)
 (72) Inventors: **Luca Giulianelli**, Gerno di Lesmo (IT); **Kosei Yamashita**, Shizuoka-ken (JP)
 (73) Assignee: **YAMAHA HATSUDOKI KABUSHIKI KAISHA**
 (**) Term: **15 Years**

D758,925 S * 6/2016 Tamura D12/110
 D805,439 S * 12/2017 Hohdorf D12/110
 D808,865 S * 1/2018 Kamitani D12/110
 D816,553 S * 5/2018 Hsieh D12/110
 D823,171 S * 7/2018 Muramatsu D12/110
 D828,230 S * 9/2018 Cammorata D12/110
 D856,854 S * 8/2019 Tamura D12/110
 D860,059 S * 9/2019 Kottmann D12/110
 D877,661 S * 3/2020 Shigihara D12/110
 D880,367 S * 4/2020 Koike D12/110
 D921,535 S * 6/2021 Selosse D12/110
 D932,376 S * 10/2021 Nishino D12/110
 D934,736 S * 11/2021 Sasaki D12/110
 D939,386 S * 12/2021 Sasanami D12/110
 D940,009 S * 1/2022 Arru D12/110

(Continued)

(21) Appl. No.: **29/772,023**

(22) Filed: **Feb. 26, 2021**

(30) **Foreign Application Priority Data**

Aug. 31, 2020 (JP) 2020-018253

(51) **LOC (13) Cl.** **12-11**

(52) **U.S. Cl.**
USPC **D12/110**

(58) **Field of Classification Search**
USPC D12/110, 111, 117; D21/432, 538
CPC B62K 11/00; B62K 11/02; B62K 11/04;
B62K 11/10; B62K 17/00; B62K 19/00;
B62K 2202/00

See application file for complete search history.

(56) **References Cited**

U.S. PATENT DOCUMENTS

D601,460 S * 10/2009 Wong D12/110
 D666,535 S * 9/2012 Kiska D12/110
 8,485,299 B2 * 7/2013 Iida B62J 35/00
 280/833
 D688,983 S * 9/2013 Shibuta D12/110
 D718,670 S * 12/2014 Kiska D12/110
 D735,085 S * 7/2015 Buckan D12/110
 D744,905 S * 12/2015 Shibuta D12/110

OTHER PUBLICATIONS

“2019 Yamaha MT-10: A liter-class naked sportbike built for fast street riding.” Cycle World., Oct. 19, 2018 [online], [retrieved on Jan. 31, 2021]. Retrieved from the Internet <URL: <https://www.cycleworld.com/2019-yamaha-mt-10/>>.*

(Continued)

Primary Examiner — Darlington Ly

(74) *Attorney, Agent, or Firm* — Ostrolenk Faber LLP

(57) **CLAIM**

The ornamental design for a motorcycle, as shown.

DESCRIPTION

FIG. 1 is a front, left side, perspective view of a motorcycle showing our new design;
 FIG. 2 is a rear, right side, perspective view thereof;
 FIG. 3 is a front elevation view thereof;
 FIG. 4 is a rear elevation view thereof;
 FIG. 5 is a right side elevation view thereof;
 FIG. 6 is a left side elevation view thereof; and,
 FIG. 7 is a top plan view thereof.

1 Claim, 7 Drawing Sheets

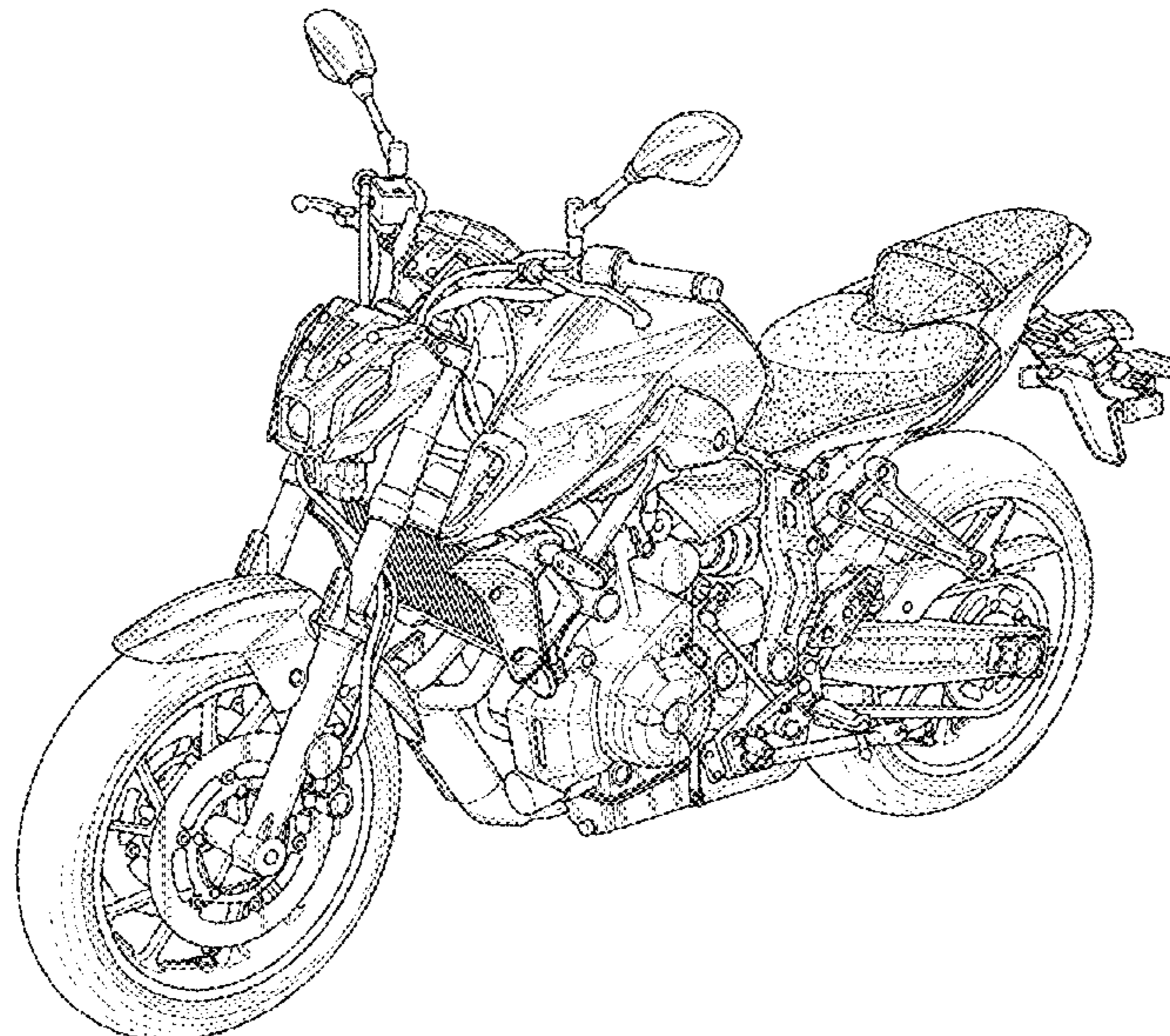

(56)

References Cited

U.S. PATENT DOCUMENTS

2012/0318598 A1* 12/2012 Fujiyama B60K 5/12
180/219
2014/0084565 A1* 3/2014 Nakamura B62K 25/283
280/284

OTHER PUBLICATIONS

“2021 Yamaha MT-03.” Yamaha., Dec. 3, 2020 [online], [retrieved on Jan. 31, 2021]. Retrieved from the Internet <URL: https://www.yamahamotorsports.com/content/common/dpg/files/2021_yamaha_MT-03.pdf>.*

“3 Reasons To Wait For 2021 Yamaha MT-03 Naked Street Fighter.” Life on Two Wheels., Oct. 14, 2020 [online], [retrieved on Jan. 31, 2021]. Retrieved from the Internet <URL: <https://www.lifeontwowheelsride.com/3-reasons-to-wait-for-2021-yamaha-mt-03-naked-street-fighter/>>.*

Sabrina Giacomini. “Spec Showdown: Yamaha MT-03 Vs. Kawasaki Z400.” Ride Apart., Jun. 23, 2020 [online], [retrieved on Jan. 31, 2021]. Retrieved from the Internet <URL: <https://www.rideapart.com/news/430343/comparison-specs-yamaha-mt03-kawasaki-z400/>>.*

* cited by examiner

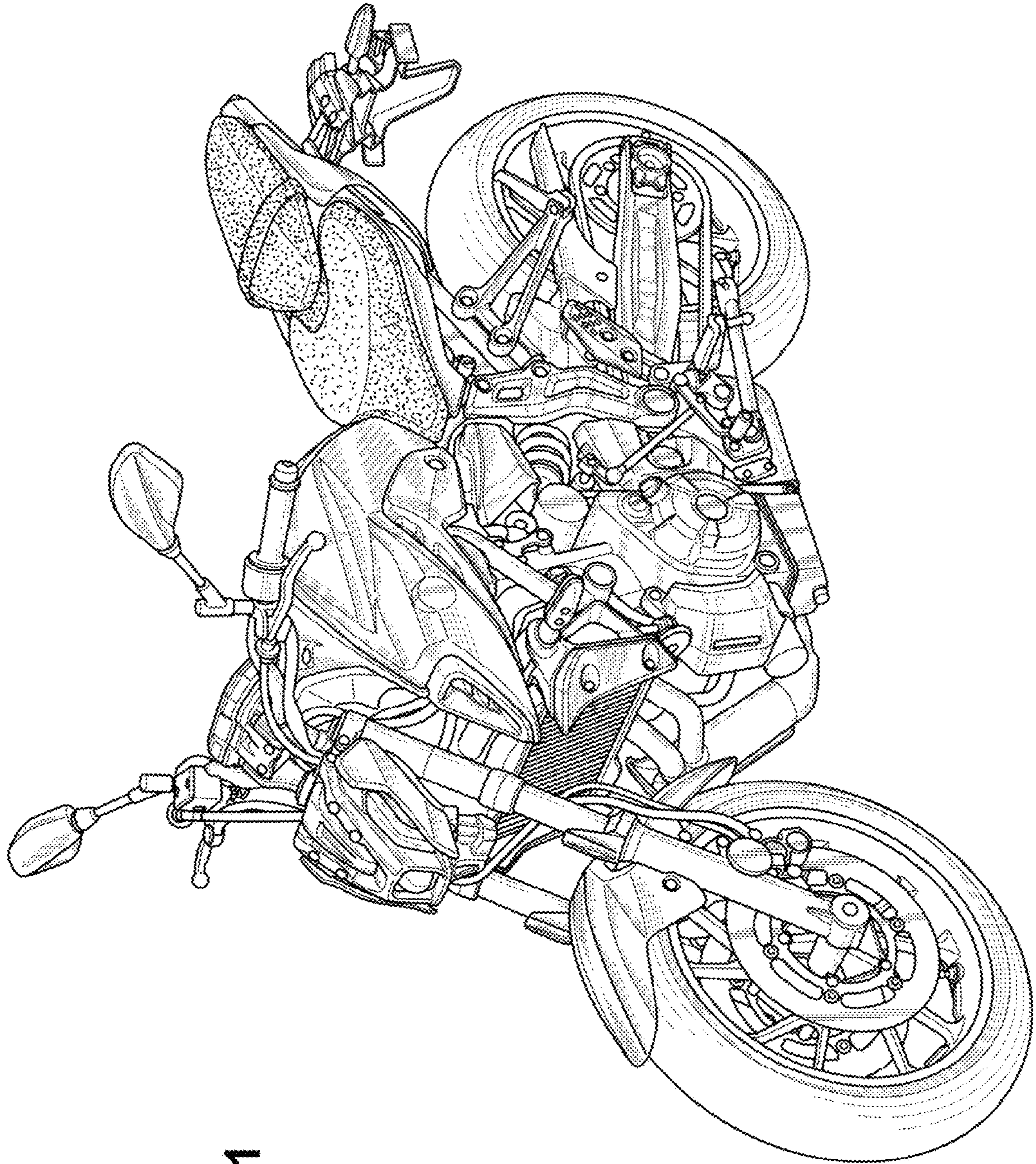

FIG. 1

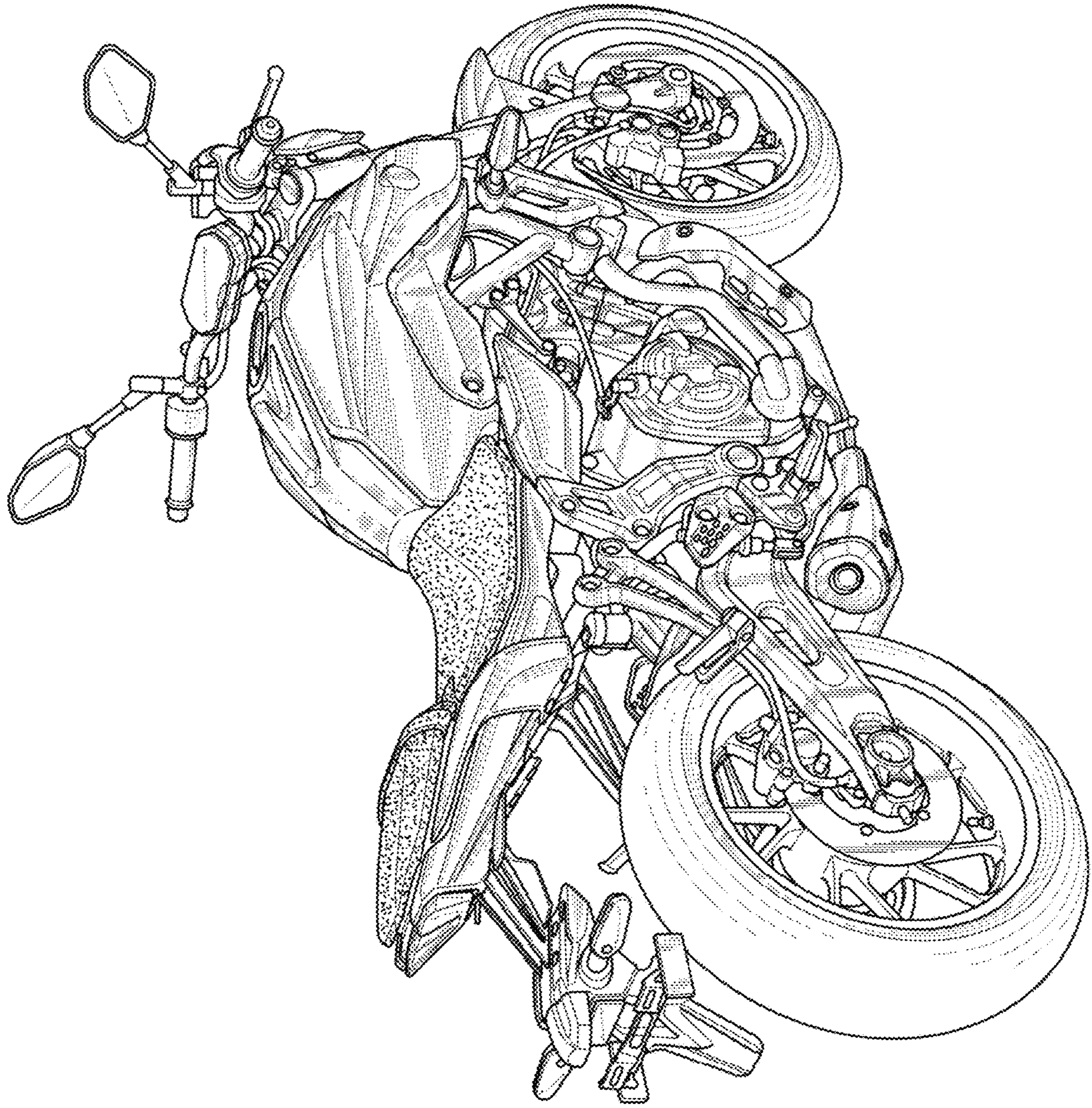

FIG. 2

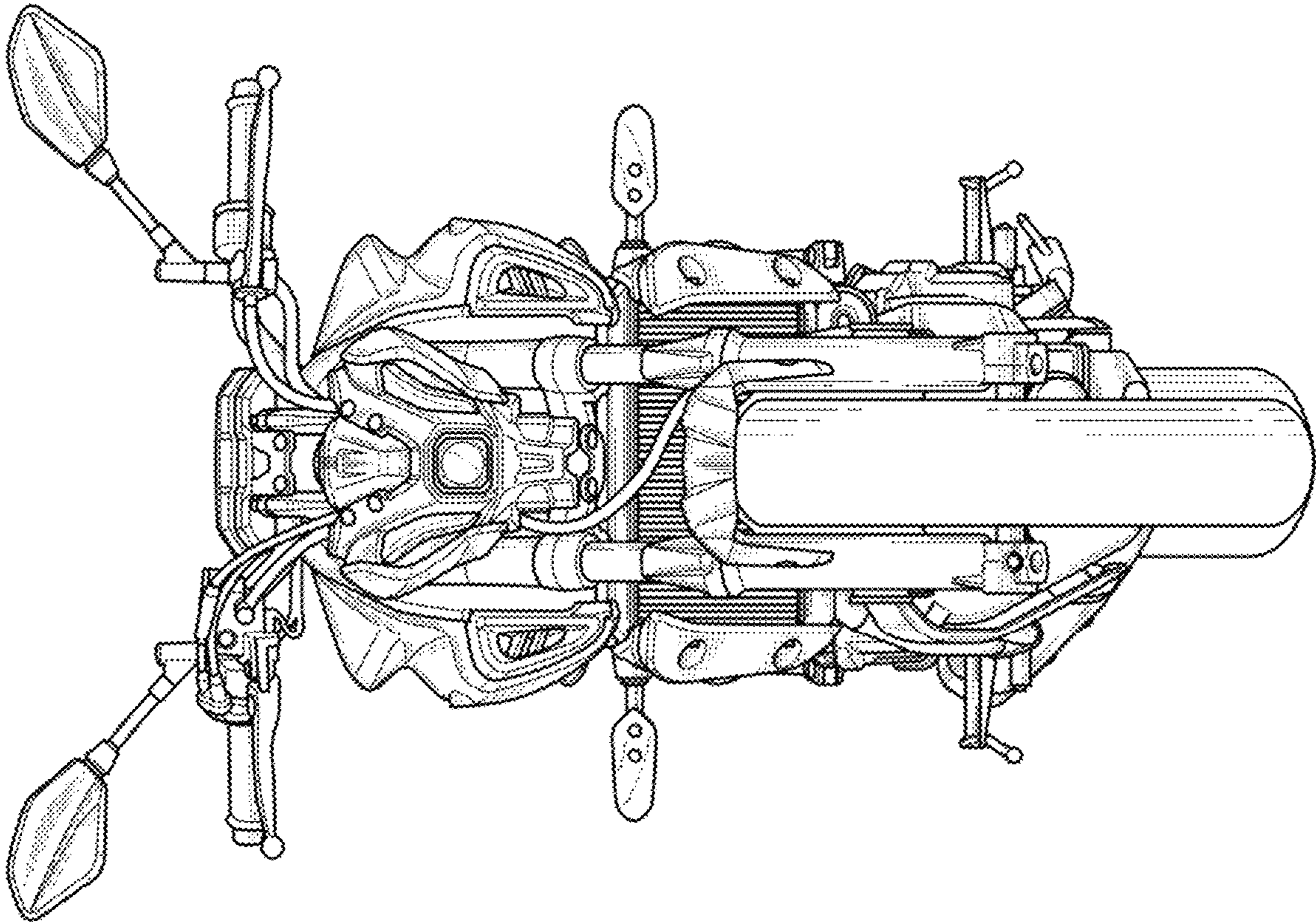

FIG. 3

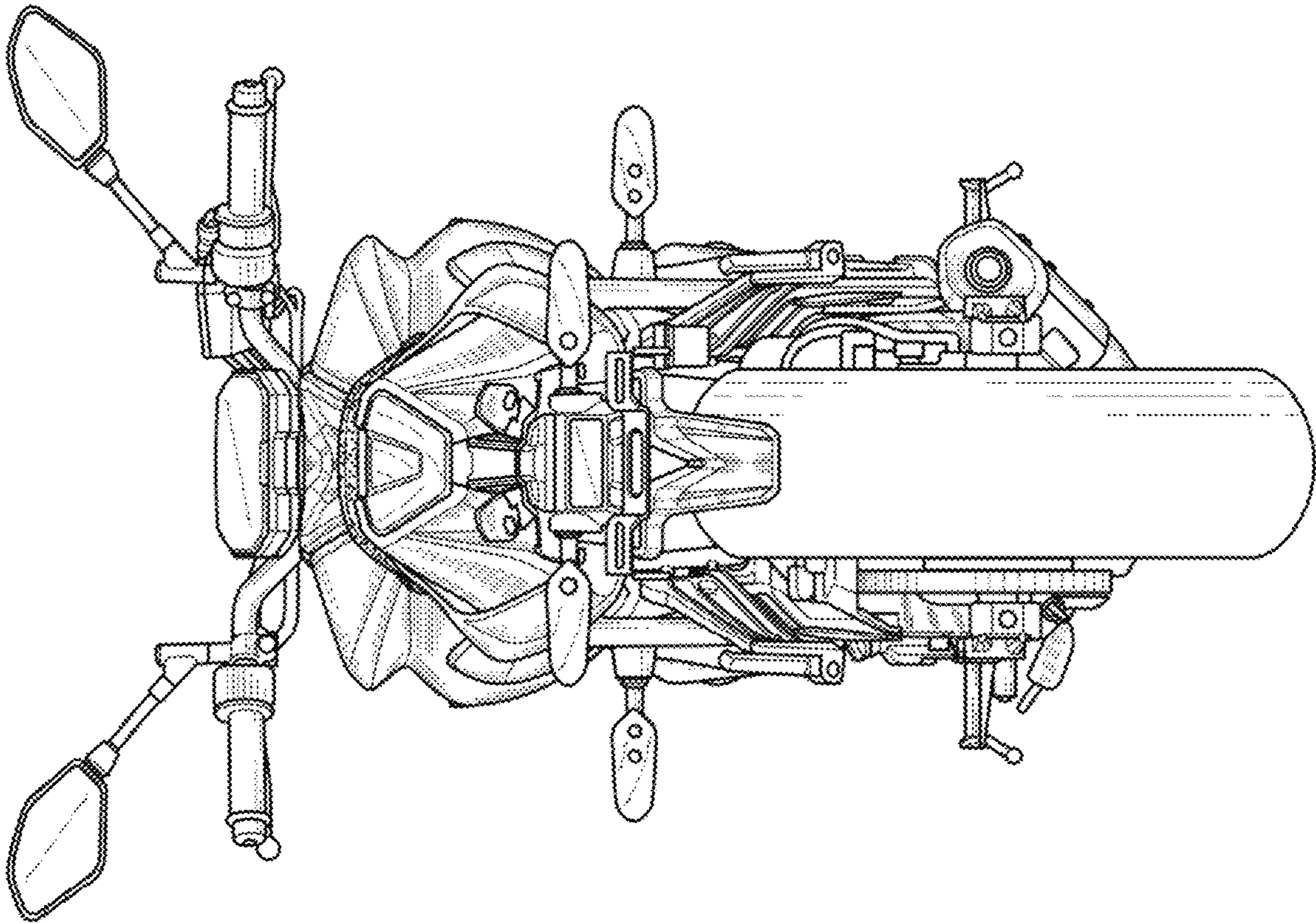

FIG. 4

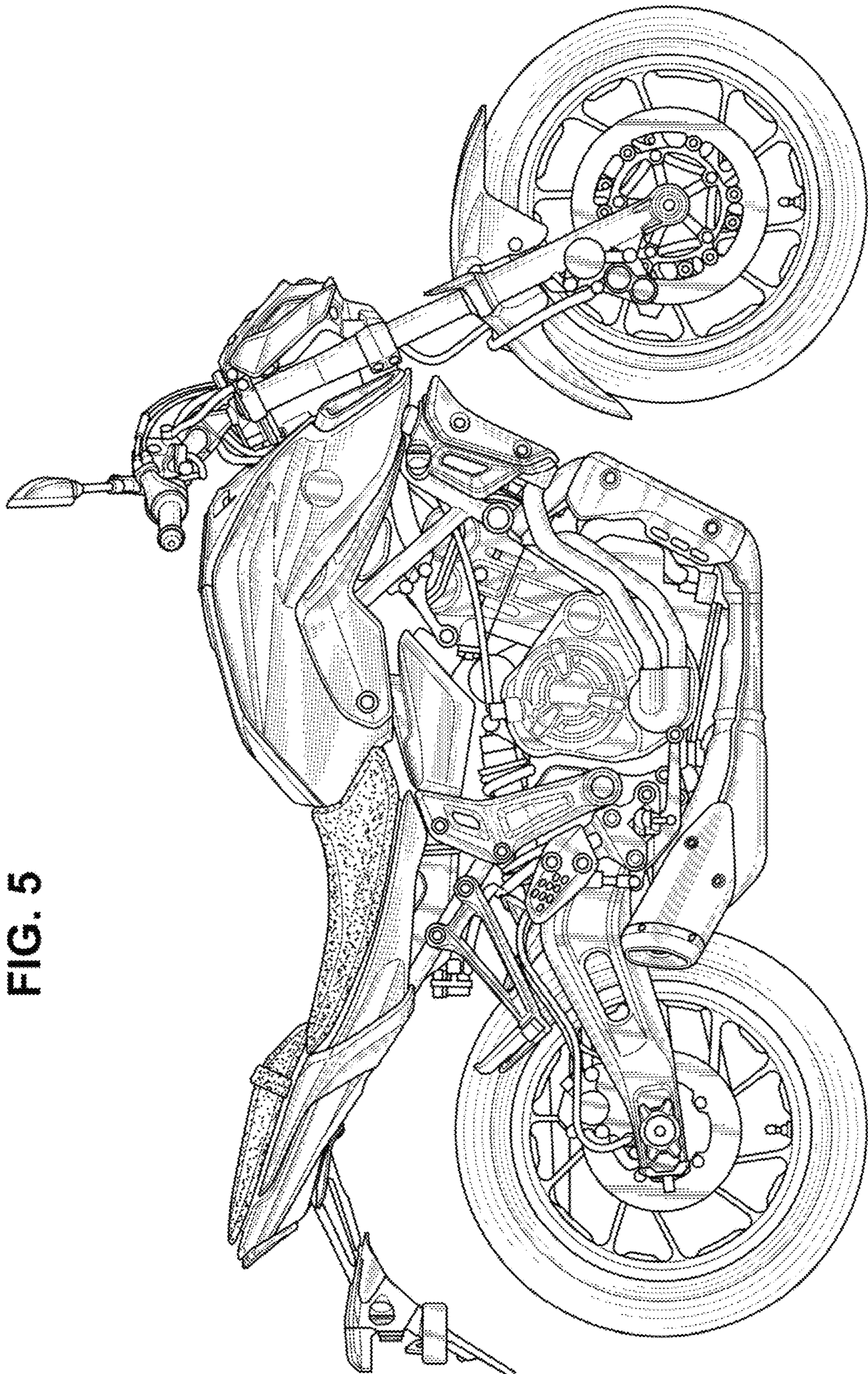

FIG. 5

FIG. 6

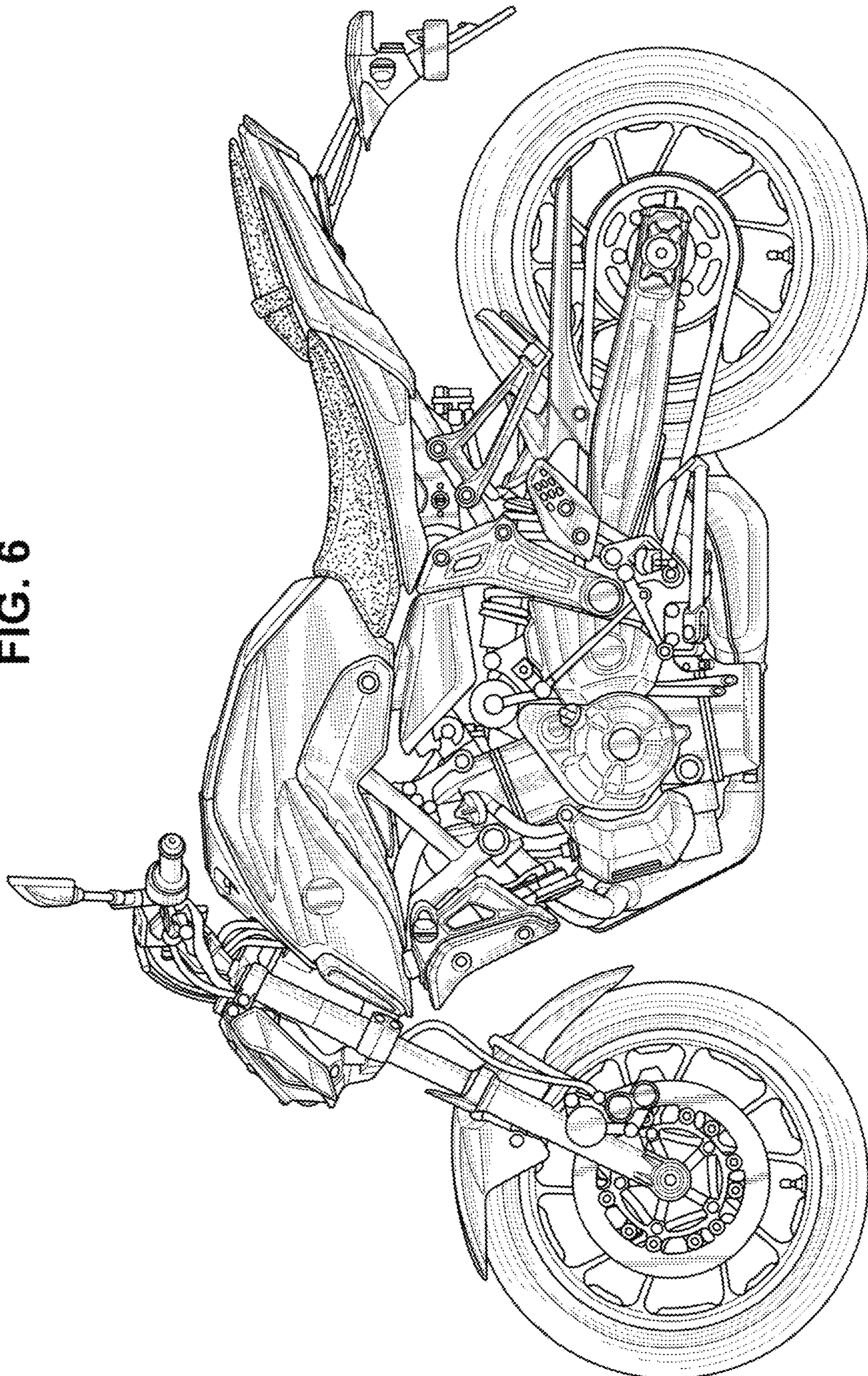

FIG. 7

