



US00D959250S

(12) **United States Design Patent** (10) **Patent No.:** **US D959,250 S**  
**Stahl et al.** (45) **Date of Patent:** **\*\* Aug. 2, 2022**

(54) **SLIDE CLIP**

(71) Applicant: **Clarkwestern Dietrich Building Systems LLC**, West Chester, OH (US)

(72) Inventors: **Gregg Allan Stahl**, Lebanon, OH (US); **Brett Daniel Hironimus**, Beaver Falls, PA (US)

(\*\*) Term: **15 Years**

(21) Appl. No.: **29/743,533**

(22) Filed: **Jul. 22, 2020**

(51) **LOC (13) Cl.** ..... **08-05**

(52) **U.S. Cl.**  
 USPC ..... **D8/382; D25/199**

(58) **Field of Classification Search**  
 USPC ..... D8/349, 354, 355, 371, 373, 380, 381, D8/382; D25/199  
 CPC ..... E04B 2/768; E04B 2/789; E04B 2/828; E04B 2/90; E04B 1/2403; E04B 1/40; E04B 2001/2415; E04B 2001/2439; E04B 2001/2448; E04B 2001/2457; E04B 2001/405

See application file for complete search history.

3,940,900 A	3/1976	Russo
4,022,415 A	5/1977	Roderick
4,035,093 A	7/1977	Redshaw
4,060,905 A	12/1977	Light
4,097,012 A	6/1978	McIntyre
4,131,221 A	12/1978	Yeager
4,194,333 A	3/1980	Paton
4,251,969 A	2/1981	Bains
4,263,764 A	4/1981	Wendt
4,321,776 A	3/1982	Delight
4,363,459 A	12/1982	Holzer
4,409,765 A	10/1983	Pall
D272,719 S	2/1984	Skjaeveland
4,433,524 A	2/1984	Matson
4,464,074 A	8/1984	Green et al.
4,709,517 A	12/1987	Mitchell
4,723,747 A	2/1988	Karp et al.
4,765,108 A	8/1988	Lapish
4,796,403 A	1/1989	Fulton
4,815,734 A	3/1989	Verhulst
4,835,935 A	6/1989	Murphy
4,899,510 A	2/1990	Propst
4,918,893 A	4/1990	Vandenbroucke et al.
4,932,173 A	6/1990	Commins
4,949,929 A	8/1990	Kesselman et al.
D310,478 S	9/1990	Lang
4,955,172 A	9/1990	Pierson
D312,962 S	12/1990	Overton
5,004,369 A	4/1991	Young
5,009,557 A	4/1991	Dessirier
5,027,494 A	7/1991	Martin
5,040,345 A	8/1991	Gilmour
5,090,171 A	2/1992	Kano
5,118,060 A	6/1992	Spronken
5,152,117 A	10/1992	Wynar
5,169,062 A	12/1992	Baker
5,201,787 A	4/1993	LaLonde et al.
5,216,858 A	6/1993	Gilmour
5,217,317 A	6/1993	Young
D339,735 S	9/1993	Brennan
5,271,586 A	12/1993	Schmidt
5,313,752 A	5/1994	Hatzinikolas
5,375,382 A	12/1994	Weidlinger
5,392,579 A	2/1995	Champagne
5,392,581 A	2/1995	Hatzinikolas
5,408,724 A	4/1995	Mullet
D360,571 S	7/1995	Perry
5,454,203 A	10/1995	Turner
5,457,928 A	10/1995	Sahnazarian
5,467,566 A	11/1995	Swartz et al.
5,529,273 A	6/1996	Benthin
D371,506 S	7/1996	Nofziger
D373,902 S	9/1996	Wang

(56) **References Cited**  
 U.S. PATENT DOCUMENTS

1,188,959 A	6/1916	McAlarney
1,400,007 A	12/1921	Sparks
1,486,509 A	3/1924	Whittaker
1,600,794 A	9/1926	Brown
2,058,386 A	10/1936	Parsons
2,235,761 A	3/1941	Goldsmith
2,258,574 A	10/1941	Leary
2,365,478 A	12/1944	La Grotta
3,003,600 A	10/1961	Mackenzie
3,113,358 A	12/1963	Zell
3,350,830 A	11/1967	Smith et al.
3,353,312 A	11/1967	Storch
3,445,977 A	5/1969	Latiano
3,490,797 A	1/1970	Platte
3,753,325 A	8/1973	Stanley
3,798,865 A	3/1974	Curtis

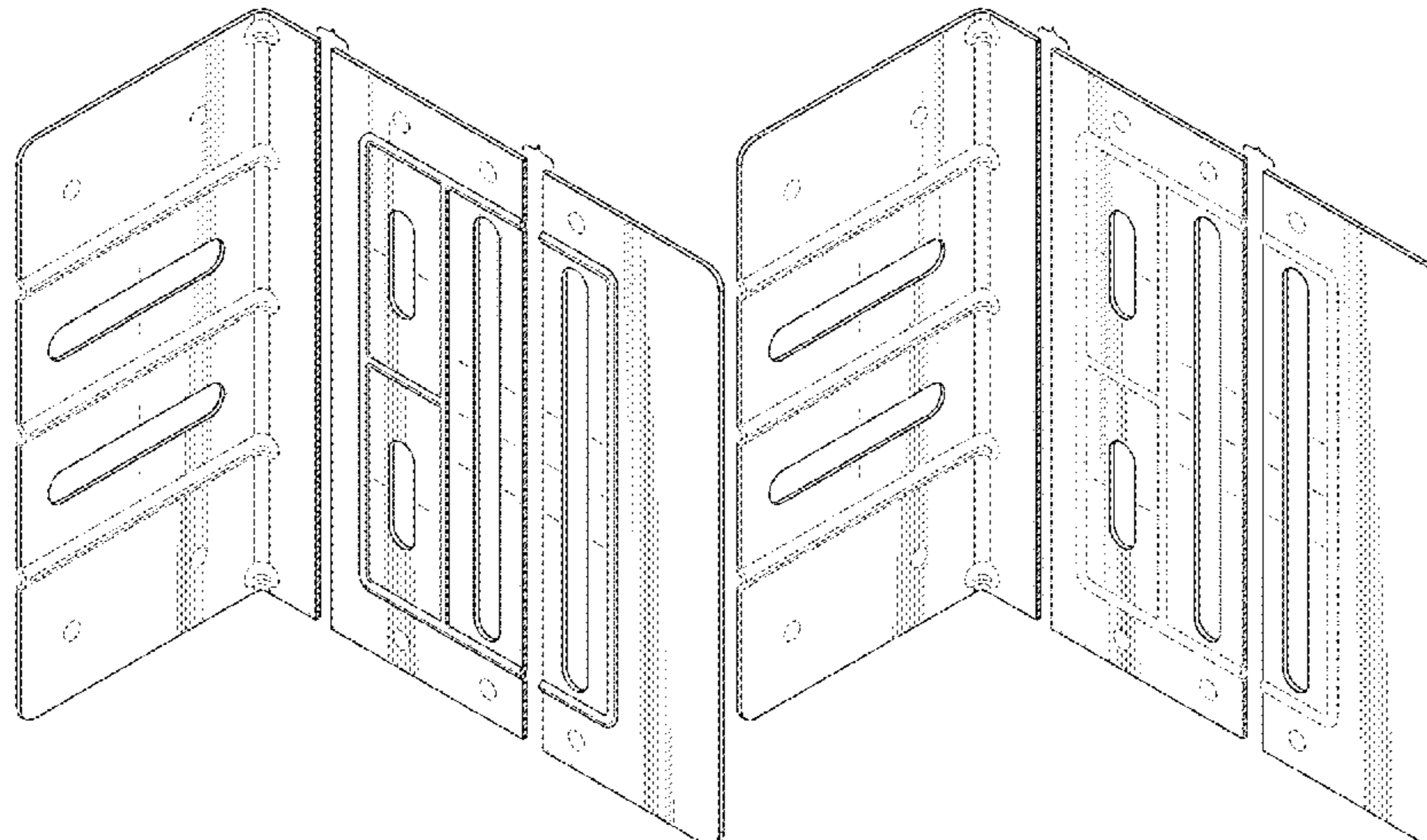



# US D959,250 S

5,554,392 A	9/1996	Gray		7,614,195 B2	11/2009	Platt et al.	
D375,038 S	10/1996	Trevorrow		D608,183 S	1/2010	Meyer	
5,572,844 A	11/1996	Stackenwalt et al.		7,658,356 B1	2/2010	Nehls	
5,611,179 A	3/1997	Leek		D621,692 S	8/2010	Clarke	
5,640,823 A	6/1997	Bergeron et al.		D628,539 S	12/2010	Tezak et al.	
5,664,392 A	9/1997	Mucha		D630,346 S	1/2011	Horta	
5,664,754 A	9/1997	Gaenslen		7,902,457 B2	3/2011	Johnson	
5,671,580 A	9/1997	Chou		7,918,054 B2	4/2011	Grafton et al.	
5,678,797 A	10/1997	Gogan		D638,286 S *	5/2011	Tedesco	D8/394
5,685,121 A	11/1997	DeFrancesco		D640,916 S *	7/2011	Sias	D8/382
5,718,533 A	2/1998	Mullet		D644,503 S *	9/2011	Crane	D8/382
5,720,571 A	2/1998	Frobosilo et al.		D649,016 S	11/2011	Rasmussen	
5,743,063 A	4/1998	Boozer		D652,951 S	1/2012	Crane et al.	
5,779,206 A	7/1998	Harris et al.		8,091,316 B2	1/2012	Beck et al.	
D398,820 S	9/1998	Cougar		8,181,419 B1	5/2012	diGirolamo	
5,810,303 A	9/1998	Bourassa et al.		D663,020 S	7/2012	Purnell	
D400,081 S	10/1998	Ibaragi		D663,190 S	7/2012	Mota et al.	
5,836,133 A	11/1998	Bergeron et al.		8,234,826 B1	8/2012	Proffitt, Jr.	
5,846,018 A	12/1998	Frobosilo et al.		8,240,103 B2	8/2012	Riepe	
5,857,306 A	1/1999	Pellock		D667,288 S *	9/2012	Preda	D8/354
5,876,006 A	3/1999	Sharp et al.		D667,289 S *	9/2012	Preda	D8/354
D408,266 S	4/1999	Santiago		8,272,806 B2	9/2012	Mogar et al.	
5,904,023 A	5/1999	diGirolamo et al.		8,281,541 B2	10/2012	Lucey et al.	
5,906,080 A	5/1999	diGirolamo et al.		8,347,581 B2	1/2013	Doerr et al.	
5,924,259 A	7/1999	Marousek		8,387,321 B2	3/2013	diGirolamo et al.	
5,937,605 A	8/1999	Wendt		D684,033 S	6/2013	Preda	
D414,398 S	9/1999	Benz et al.		8,453,407 B2	6/2013	Tedesco et al.	
5,956,916 A	9/1999	Liss		8,511,032 B2	8/2013	Abdel-Rahman et al.	
6,009,681 A	1/2000	Kozloff		8,544,229 B2	10/2013	Kilgore et al.	
D420,565 S	2/2000	Griffiths		8,555,592 B2	10/2013	Daudet et al.	
6,018,923 A	2/2000	Wendt		D692,746 S	11/2013	Lawson et al.	
D422,886 S *	4/2000	Shea	D8/354	8,590,257 B2	11/2013	Yurko, Sr.	
6,058,668 A	5/2000	Herren		8,615,942 B2	12/2013	LaFreniere	
6,088,982 A	7/2000	Hiesberger		8,615,948 B2	12/2013	Underkofler et al.	
D432,901 S	10/2000	McDonald		8,683,770 B2	4/2014	diGirolamo et al.	
6,138,425 A	10/2000	Wendt		8,713,872 B2	5/2014	Rempel	
6,199,929 B1	3/2001	Hansch		8,763,336 B2	7/2014	Gulbrandsen et al.	
6,213,679 B1	4/2001	Frobosilo et al.		8,769,887 B2	7/2014	Proffitt, Jr.	
D442,471 S *	5/2001	Willett	D8/354	8,800,232 B1	8/2014	Keenan	
6,250,041 B1	6/2001	Seccombe		8,813,457 B2	8/2014	Underkofler et al.	
D451,786 S	12/2001	Wyatt et al.		8,833,008 B2	9/2014	Truckner	
6,427,416 B1	8/2002	Rassel		8,950,151 B2	2/2015	Strickland et al.	
6,508,447 B1	1/2003	Catani et al.		8,973,333 B2	3/2015	Sugihara et al.	
6,523,322 B1	2/2003	Michalski et al.		8,998,137 B2	4/2015	Braeutigam et al.	
6,585,448 B2	7/2003	Grossman		9,010,070 B2	4/2015	Darr, III et al.	
6,609,344 B2	8/2003	Saldana		D729,611 S	5/2015	Schmidt	
6,612,087 B2	9/2003	diGirolamo et al.		D730,545 S	5/2015	Stauffer et al.	
D482,261 S	11/2003	Kobayashi		9,032,681 B1	5/2015	Brady	
D482,598 S	11/2003	Brass		D731,876 S *	6/2015	Di Stefano	D8/363
6,688,069 B2	2/2004	Zadeh		D732,708 S	6/2015	Stauffer et al.	
6,741,703 B1	5/2004	Clour		9,045,892 B2	6/2015	Smith et al.	
6,792,733 B2	9/2004	Wheeler et al.		9,091,056 B2	7/2015	Stauffer et al.	
6,871,470 B1	3/2005	Stover		9,140,000 B1	9/2015	Brady	
D517,402 S	3/2006	Cairns		D740,108 S	10/2015	Di Stefano	
7,021,021 B2	4/2006	Saldana		9,234,344 B2	1/2016	Hatzinikolas	
7,065,932 B2	6/2006	Roesset et al.		9,255,403 B1	2/2016	Lehane et al.	
D527,986 S	9/2006	Johnson		D751,222 S	3/2016	Darr, III et al.	
7,104,024 B1	9/2006	di Girolamo et al.		D751,733 S	3/2016	Darr, III et al.	
D530,191 S	10/2006	Taylor		9,290,928 B2	3/2016	Klein	
7,127,862 B2	10/2006	Saldana		D753,638 S	4/2016	Tatem et al.	
D532,290 S	11/2006	David		D766,701 S	9/2016	Snell	
D533,445 S	12/2006	Janzen		D769,698 S	10/2016	Oltrogge	
D536,954 S	2/2007	Sjoberg		D774,874 S	12/2016	Wentzel et al.	
7,174,690 B2	2/2007	Zadeh		9,663,948 B2	5/2017	Lehane et al.	
7,178,304 B2	2/2007	Brady		9,677,269 B2	6/2017	Wright	
D543,834 S	6/2007	Worthy		D810,546 S *	2/2018	Shaw	D8/363
7,293,393 B2	11/2007	Kelly et al.		9,896,840 B2	2/2018	Ting	
7,299,593 B1 *	11/2007	diGirolamo	E04B 2/58 52/274	9,909,312 B2	3/2018	Lehane et al.	
				D814,905 S *	4/2018	Ralph	D8/349
7,356,973 B2	4/2008	Roesset et al.		D815,313 S *	4/2018	Ralph	D25/199
D569,232 S	5/2008	Yoshida		D815,314 S *	4/2018	Ralph	D25/199
D572,114 S	7/2008	Segovia		D815,315 S *	4/2018	Ralph	D25/199
D576,473 S	9/2008	Cresswell		D815,316 S *	4/2018	Ralph	D25/199
7,478,508 B2	1/2009	Peterson		D817,149 S *	5/2018	Ralph	D8/349
D587,100 S	2/2009	Allsopp		10,024,048 B2	7/2018	Getz	
7,503,150 B1	3/2009	di Girolamo et al.		10,132,341 B2	11/2018	di Girolamo et al.	
7,533,508 B1 *	5/2009	diGirolamo	E04B 2/58 403/231	10,724,229 B2 *	7/2020	Daudet	E04B 1/2403
				D906,788 S *	1/2021	Ochi	D8/354
D595,114 S	6/2009	Hamilton		10,961,704 B2	3/2021	Daudet	



# US D959,250 S

Page 3

D931,496	S *	9/2021	Melin .....	D25/38.1
D943,404	S *	2/2022	Tran .....	D8/373
2002/0023405	A1	2/2002	Zadeh	
2002/0062617	A1	5/2002	di Girolamo et al.	
2005/0279901	A1	12/2005	McCoy et al.	
2006/0026924	A1	2/2006	Madsen	
2006/0032183	A1	2/2006	Peterson	
2006/0096192	A1	5/2006	Daudet	
2006/0196143	A1 *	9/2006	Roesset .....	E04C 3/12 52/712
2007/0089841	A1	4/2007	Rossato et al.	
2008/0053034	A1	3/2008	Matechuk et al.	
2008/0163581	A1	7/2008	Greth	
2008/0258026	A1	10/2008	Smith et al.	
2009/0113827	A1	5/2009	Stone et al.	
2009/0193750	A1	8/2009	Klima	
2010/0083606	A1	4/2010	Davis et al.	
2010/0126103	A1 *	5/2010	diGirolamo .....	E04B 2/767 52/655.1
2011/0197541	A1	8/2011	Knoop	
2011/0219720	A1	9/2011	Strickland et al.	
2012/0247059	A1 *	10/2012	Daudet .....	E04B 1/2403 52/698
2013/0125400	A1	5/2013	Clapp et al.	
2013/0139466	A1	6/2013	Abdel-Rahman et al.	
2014/0290175	A1	10/2014	Klein	
2014/0352249	A1	12/2014	Jankovec et al.	
2015/0159369	A1	6/2015	Chen et al.	
2015/0308098	A1	10/2015	Tessadori	
2016/0333579	A1	11/2016	Stein	
2017/0044787	A1	2/2017	di Girolamo et al.	
2017/0204599	A1	7/2017	Daudet et al.	
2017/0204600	A1	7/2017	Daudet et al.	
2018/0066424	A1 *	3/2018	Daudet .....	E04B 2/768
2018/0066425	A1 *	3/2018	Ralph .....	E04B 1/2403
2018/0135293	A1	5/2018	Daudet	
2018/0148920	A1	5/2018	Delfeld	
2018/0266101	A1 *	9/2018	Haba .....	E04B 1/40
2022/0025637	A1 *	1/2022	Stahl .....	E04B 1/40

## FOREIGN PATENT DOCUMENTS

CA	2165643	A1	6/1996
CA	2243897	A1	2/1999
CA	2217076	A1	4/1999
CA	2260554	A1	7/1999
CA	2742742	A1	3/2010
CA	2463747	C	1/2011
CA	2830677	A1	10/2012
CA	2940128	A1	10/2012
CA	2934777	A1	7/2015
CA	2838361	C	4/2016
CA	162955	S	5/2016
CA	2784885	C	4/2017
CN	303539282		1/2016
EP	1 070 904	B1	2/2005
EP	2 093 335	A2	8/2009
EP	2 093 336	A2	8/2009
EP	1 770 840	B1	11/2009
JP	D 1330583		5/2008
WO	WO 00/07483	A1	2/2000
WO	WO 2007/115351	A1	10/2007
WO	WO 2010/009727	A1	1/2010
WO	WO 2010/092563	A1	8/2010
WO	WO 2014/004363	A1	1/2014
WO	WO 2014/193486	A1	12/2014
WO	WO 2015/003216	A1	1/2015
WO	WO 2015/101582	A2	7/2015
WO	WO 2016/028500	A1	2/2016

## OTHER PUBLICATIONS

ClarkDietrich FastClip YouTube <https://www.youtube.com/watch?v=XLbGZBs6Mwc> Mar. 28, 2014 (Year: 2014).\*

ClarkDietrich FastClip Slide Clip Benefast <https://benefast.com/product/clarkdietrich-fastclip-slide-clip-14-gauge-5-1-2-x-1-1-2-x-4-1-2-inc-80-screws-fcsc-5-5-68-25-box/> Sep. 2020 (Year: 2020).\*

Clamp L Shape Bracket, MiSumi, USA, 2012 Metric Catalog, p. 1-1552, downloaded from [https://us.misumi-ec.com/pdf/fa/2012/p1\\_1551.pdf](https://us.misumi-ec.com/pdf/fa/2012/p1_1551.pdf), 1 pg.

ClarkDietrich Drift FastClip Slide Clip, downloaded from <https://www.youtube.com/watch?v=c0v0plodJQ8>, posted Feb. 3, 2017, 1 pg.

Curtainwall Deflection Solutions, Super Stud Building Products, Inc., Brochure, 2001, 24 pgs.

Curtain Wall Brochure, The Steel Network, publication date unknown, Raleigh, North Carolina, 12 pgs.

DESC—Exterior Head-of-Wall Drift Clip, SCAFCO Steel Stud Company, Jun. 26, 2016, downloaded from <http://www.scafco.com/steel/products/deflection-clips/desc-exterior-head-of-wall-multi-drift-clip>, 2 pgs.

DISC—Interior Head-of-Wall Drift Clip, SCAFCO Steel Stud Company, Jun. 26, 2016, downloaded from <http://scafco.com/steel/products/deflection-clips/disc-interior-head-of-wall-multi-drift-clip>, 2 pgs.

Double Bypass & Triple Bypass—Curtain Vertical Deflection Clips, SSDB & SSTB Series, Product Submittal Sheet, Super Stud Building Products, Inc., 2019, downloaded Oct. 27, 2020 from [https://www.buysuperstud.com/PDF/pdf/SuperStud%20Triple%20Bypass%20Vertical%20Deflection%20Clips%20\(SSTB\).pdf](https://www.buysuperstud.com/PDF/pdf/SuperStud%20Triple%20Bypass%20Vertical%20Deflection%20Clips%20(SSTB).pdf), 2 pgs.

DPLC2—Bypass Slab Drift Clip, SCAFCO Steel Stud Company, Jun. 16, 2016, downloaded from <http://www.scalco.com/steel/products/deflection-clips/dplc2-bypass-slab-drift-strut>, 2 pgs.

DPLC2—Bypass Slab Drift Clip, SCAFCO Steel Stud Company, 2000, downloaded Oct. 27, 2020 from <https://www.scafco.com/steel/products/deflection-clips/dplc2-bypass-slab-drift-clip/>, 4 pgs.

Drift FastClip™ Slide Clip (D-FCSC), Product Submittal Sheets, ClarkDietrich Building Systems, Sep. 2020, downloaded Oct. 23, 2020 from <https://www.clarkdietrich.com/products/drift-connections/drift-fastclip-slide-clip-d-fcsc#submittals>, 6 pgs.

Drift Head-of-Wall (DHOW), Product Submittal Sheets, ClarkDietrich Building Systems, Feb. 2019, downloaded Oct. 23, 2020 from <https://www.clarkdietrich.com/products/drift-connections/drift-head-wall-dhow#submittals>, 6 pgs.

Drift Rail (DR97) and Clip (DRC), Product Submittal Sheets, ClarkDietrich Building Systems, Sep. 2020, downloaded Oct. 23, 2020 from <https://www.clarkdietrich.com/products/drift-connections/drift-rail-dr97-and-clip-drc#submittals>, 6 pgs.

Drift-Clip Bypass Framing Connector, Tech Sheet, Simpson Strong-Tie Company, Inc., May 2016, 2 pgs.

DriftClip® DSLB, Bypass Slab, Tech Sheet, The Steel Network, Inc., Jul. 2017, downloaded Oct. 27, 2020 from <https://steelnetwork.com/Product/DriftClipDSLb>, 2 pgs.

DrifTrak® DTSL, Tech Sheet, The Steel Network, Inc. (TSN), 2012, downloaded Jul. 6, 2017 from <https://web.archive.org/web/20121008023139/http://www.steelnetwork.com/product/drift-trakdtsl>, 2 pg.

DrifTrak® DTSL, The Steel Network, downloaded from <https://www.steelnetwork.com/Product/DrifTrakDTSL>, available Apr. 1, 2016, 2 pgs.

DrifTrak® DTSLB, Tech Sheet, The Steel Network, Inc. (TSN), 2012, downloaded Jul. 6, 2017 from <https://web.archive.org/web/20121008022926/http://www.steelnetwork.com/product/drift-trakdtslb>, 3 pgs.

DWSC Slide Clips, FrameRite Connectors, Marino Ware, Jun. 16, 2016, downloaded from <http://www.marinoware.com/Products/frameriteConn.asp?prod=5>, 1 pg.

Extended FastClip™ (FCEC), Product Submittal Sheets, ClarkDietrich Building Systems, Oct. 2018, downloaded Oct. 23, 2020 from <https://www.clarkdietrich.com/products/curtain-wall-bypass-connections/extended-fastclip-fcec#submittals>, 5 pgs.

Fast Strut™ (FS12, FS15, FS18, FS20, FS22, FS24), Product Submittal Sheets, ClarkDietrich Building Systems, Sep. 2020, downloaded Oct. 23, 2020 from <https://www.clarkdietrich.com/products/curtain-wall-bypass-connections/fast-strut-fs12-fs15-fs18-fs20-fs22-fs24#submittals>, 6 pgs.

Fast Top™ Clip (FTC), Product Submittal Sheets, ClarkDietrich Building Systems, Sep. 2020, downloaded Oct. 23, 2020 from <https://www.clarkdietrich.com/products/head-wall-deflection-connections/fast-top-clip-ftc#submittals>, 5 pgs.



FastClip™ Slide Clip (FCSC-HD) w/Anchor Holes, Product Submittal Sheet, ClarkDietrich Building Systems, Sep. 2020, downloaded Oct. 23, 2020 from <https://www.clarkdietrich.com/products/curtain-wall-bypass-connections/fastclip-slide-clip-fcsc-hd-w-anchor-holes#submittals>, 1 pg.

FastClip™ Slide Clips (FCSC), Product Submittal Sheets, ClarkDietrich Building Systems, Jan. 2020, downloaded Oct. 23, 2020 from <https://www.clarkdietrich.com/products/curtain-wall-bypass-connections/fastclip-slide-clips-fcsc#submittals>, 3 pgs.

Flat Tail™ Slide Clip (FTSC), Product Submittal Sheets, ClarkDietrich Building Systems, Sep. 2020, downloaded Oct. 23, 2020 from <https://www.clarkdietrich.com/products/curtain-wall-bypass-connections/flat-tail-slide-clip-ftsc#submittals>, 4 pgs.

IDCB Drift-Clip Bypass Framing Connector, Catalog pages, Simpson Strong-Tie, 2000, downloaded Oct. 27, 2020 from [https://www.strongtie.com/driftconnectors\\_coldformedsteelconstruction/idcb\\_clip/p/idcb](https://www.strongtie.com/driftconnectors_coldformedsteelconstruction/idcb_clip/p/idcb), 1 pg.

MasterClip® VLB, Bypass Slab, Tech Sheet, The Steel Network, Inc., May 2019, downloaded Oct. 27, 2020 from <https://steelnetwork.com/Product/MastorClipVLB>, 2 pgs.

PLC2—Bypass Slab Slide Clip, SCAFCO Steel Stud Company, 2000, downloaded Oct. 27, 2020 from <https://www.scafco.com/steel/products/deflection-clips/plc2-bypass-slab-slide-clip/>, 3 pgs.

PLC4—Bypass Slab Slide Clip, SCAFCO Steel Stud Company, Jun. 7, 2017, downloaded from <http://www.scafco.com/steel/products/deflection-clips/plc4-bypass-slide-clip>, 2 pgs.

SC Bypass Framing Slide-Clip Connector, Catalog pages, Simpson Strong-Tie, 2000, downloaded Oct. 27, 2020 from [https://www.strongtie.com/deflectionconnectors\\_coldformedsteelconstruction/sc\\_sclip/p/sc](https://www.strongtie.com/deflectionconnectors_coldformedsteelconstruction/sc_sclip/p/sc), 4 pgs.

SCB/MSCB Bypass Framing Slide-Clip Connectors, Catalog pages, Simpson Strong-Tie, 2000, downloaded Oct. 27, 2020 from [https://www.strongtie.com/deflectionconnectors\\_coldformedsteelconstruction/scb\\_clip/p/scb.mscb](https://www.strongtie.com/deflectionconnectors_coldformedsteelconstruction/scb_clip/p/scb.mscb), 3 pgs.

SCHA Slide-Clip Connectors for Horizontal Anchorage, Tech Sheet, Simpson Strong-Tie Company, Inc., Jan. 2016, 4 pgs.

SCS Seismic Bypass Framing Connector, Catalog pages, Simpson Strong-Tie, 2000, downloaded Oct. 27, 2020 from [https://www.strongtie.com/deflectionconnectors\\_coldformedsteelconstruction/scs\\_clip/p/scs](https://www.strongtie.com/deflectionconnectors_coldformedsteelconstruction/scs_clip/p/scs), 6 pgs.

SCW Head-of-Wall Slide-Clip Connectors, Submittal/Substitution Technical Information, Simpson Strong-Tie Company, Inc., Aug. 2016, 1 pg.

Simpson Strong-Tie SCW5.5-KT 5.5" Head-of-Wall Slide-Clip Connector Kit 25 pk, Nov. 19, 2016, downloaded from <http://www.fastoolnow.com/scw5-5-kt.html>, 3 pgs.

SmartFrame® VertiFlex™ SFVF, CRACO Mfg, SmartFrame® Connector System Product Catalog, Jan. 2020, p. 6, downloaded Oct. 27, 2020 from <https://cracometals.com/wp-content/uploads/2020/06/SmartFrame-Connectors-Catalog-2020.pdf>, 3 pgs.

Universal ByPass Clips (UBS), Product Submittal Sheets, ClarkDietrich Building Systems, Sep. 2020, downloaded Oct. 23, 2020 from <https://www.clarkdietrich.com/products/curtain-wall-bypass-connections/universal-bypass-clips-ubc#submittals>, 8 pgs.

VertiClip® SLB, Bypass Slab, Tech Sheet, The Steel Network, Inc., Oct. 2019, downloaded Oct. 27, 2020 from <https://steelnetwork.com/Product/VertiClipSLB>, 2 pgs.

VertiClip® SLB-HD, Bypass Slab for Seismic Conditions, Tech Sheet, The Steel Network, Inc., Dec. 2017, downloaded Oct. 27, 2020 from <https://steelnetwork.com/Product/VertiClipSLB-HD>, 1 pg.

VertiClip® SLD Metal Stud Connector for Light Gauge Steel Vertical Deflection, CAP Industries, Drywall trims, Nov. 22, 2016, downloaded from <http://www.drywalltrims.com/product/VertiClipSLD.html>, 3 pgs.

VertiClip® SLD, Interior Head of Wall, The Steel Network, Inc., Tech Sheet, Catalog pp. 11-12, 2016, downloaded from <https://www.steelnetwork.com/Product/VertiClipSLD>, 2 pgs.

WSC Slide Clips, MarinoWARE, 2000, downloaded Oct. 27, 2020 from <https://www.marinoware.com/product/wsc-slide-clips/>, 2 pgs.

Design U.S. Appl. No. 29/743,534, filed Jul. 22, 2020, by Stahl, et al., entitled: "Slide Clip."

Design U.S. Appl. No. 29/743,534.

DSSCB Bypass Framing Drift Strut Connector, Simpson Strong-Tie, 2020, downloaded Oct. 4, 2021 from [https://www.strongtie.com/driftconnectors\\_coldformedsteelconstruction/dsscb\\_clip/p/dsscb#ProductDetails](https://www.strongtie.com/driftconnectors_coldformedsteelconstruction/dsscb_clip/p/dsscb#ProductDetails), 8 pgs.

U.S. Appl. No. 17/381,436.

\* cited by examiner

*Primary Examiner* — Leanne Was-Englehart

(74) *Attorney, Agent, or Firm* — Frost Brown Todd LLC

(57)

## CLAIM

The ornamental design for a slide clip, as shown and described.

## DESCRIPTION

FIG. 1 is a front perspective view of a slide clip, showing our new design;

FIG. 2 is a rear perspective view of the slide clip of FIG. 1;

FIG. 3 is a front elevational view of the slide clip of FIG. 1;

FIG. 4 is a rear elevational view of the slide clip of FIG. 1;

FIG. 5 is a left elevational view of the slide clip of FIG. 1;

FIG. 6 is a right elevational view of the slide clip of FIG. 1;

FIG. 7 is a top plan view of the slide clip of FIG. 1;

FIG. 8 is a bottom plan view of the slide clip of FIG. 1;

FIG. 9 is a perspective assembly view of the slide clip of FIG. 1 installed in an exemplary building structure;

FIG. 10 is a front perspective view of a second embodiment of a slide clip, showing our new design;

FIG. 11 is a rear perspective view of the slide clip of FIG. 10;

FIG. 12 is a front elevational view of the slide clip of FIG. 10;

FIG. 13 is a rear elevational view of the slide clip of FIG. 10;

FIG. 14 is a left elevational view of the slide clip of FIG. 10;

FIG. 15 is a right elevational view of the slide clip of FIG. 10;

FIG. 16 is a top plan view of the slide clip of FIG. 10;

FIG. 17 is a bottom plan view of the slide clip of FIG. 10;

and,

FIG. 18 is a perspective assembly view of the slide clip of FIG. 10 installed in an exemplary building structure.

The slide clip is shown with two symbolic breaks in the length of the second plate of the slide clip. The appearance of any portion of the slide clip between the break lines forms no part of the claimed design. The through holes in the first plate shown in broken lines in FIGS. 1, 2, 5, 6, 9, 10, 11, 14, 15, and 18, the through holes in the second plate shown in broken lines in FIGS. 1-4, 9-13, and 18, the stiffeners on the first plate and in the juncture shown in broken lines in FIGS. 1-18, the indicator marks on the first plate shown in broken lines in FIGS. 1, 6, 9, 10, 15, and 18, and the indicator marks on the second plate shown in broken lines in FIGS. 1, 3, 9, 10, 12, and 18 are unclaimed subject matter and form no part of the claimed design. In addition, the fasteners and building structure shown in broken lines in FIGS. 9 and 18 are unclaimed subject matter and form no part of the claimed design. The embossments shown in broken lines on the second plate in FIGS. 10-18 are unclaimed subject matter for the embodiment shown in FIGS. 10-18. However, the embossments shown in solid lines on the second plate in FIGS. 1-9 are claimed subject matter for the embodiment shown in FIGS. 1-9.



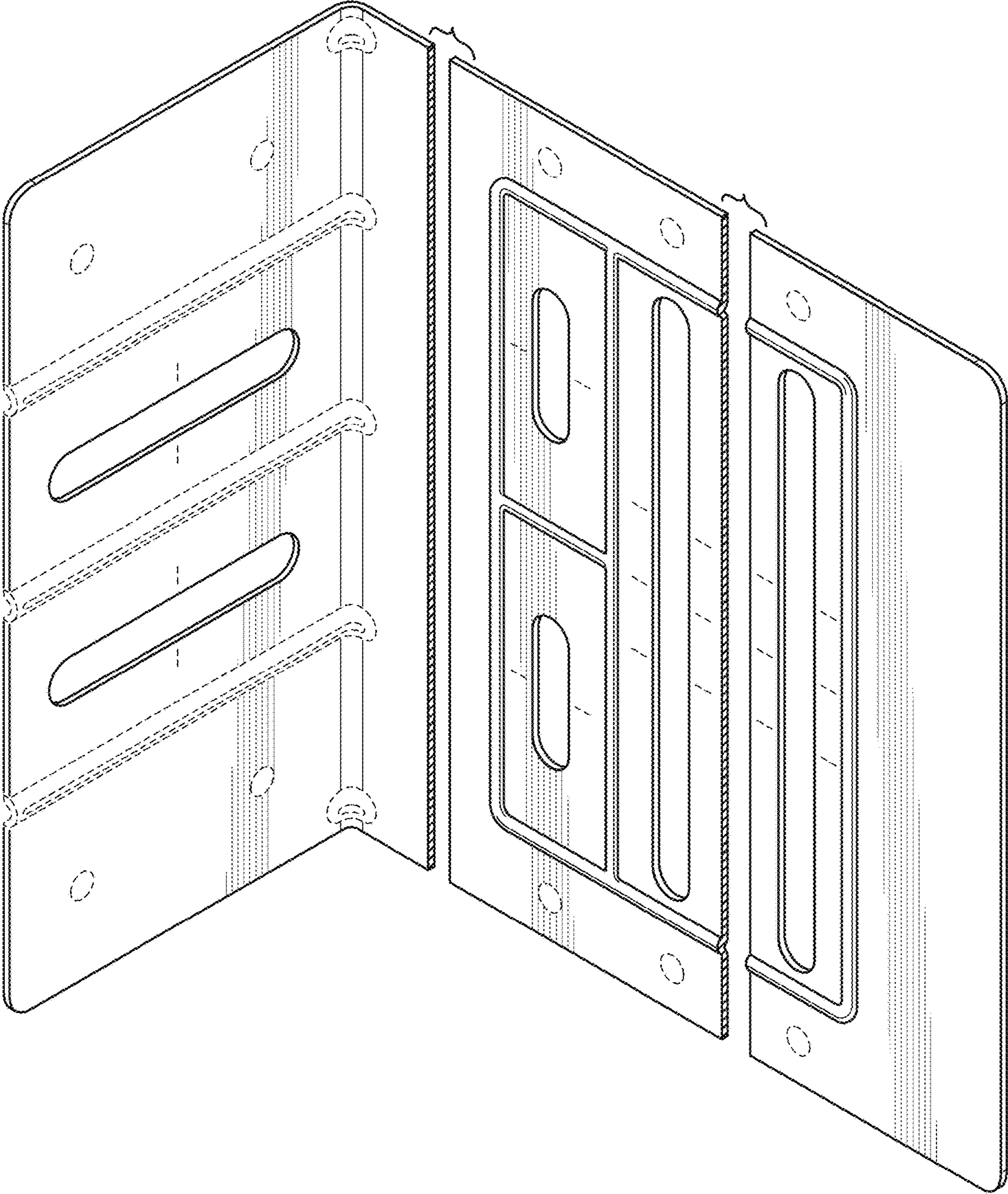

FIG. 1

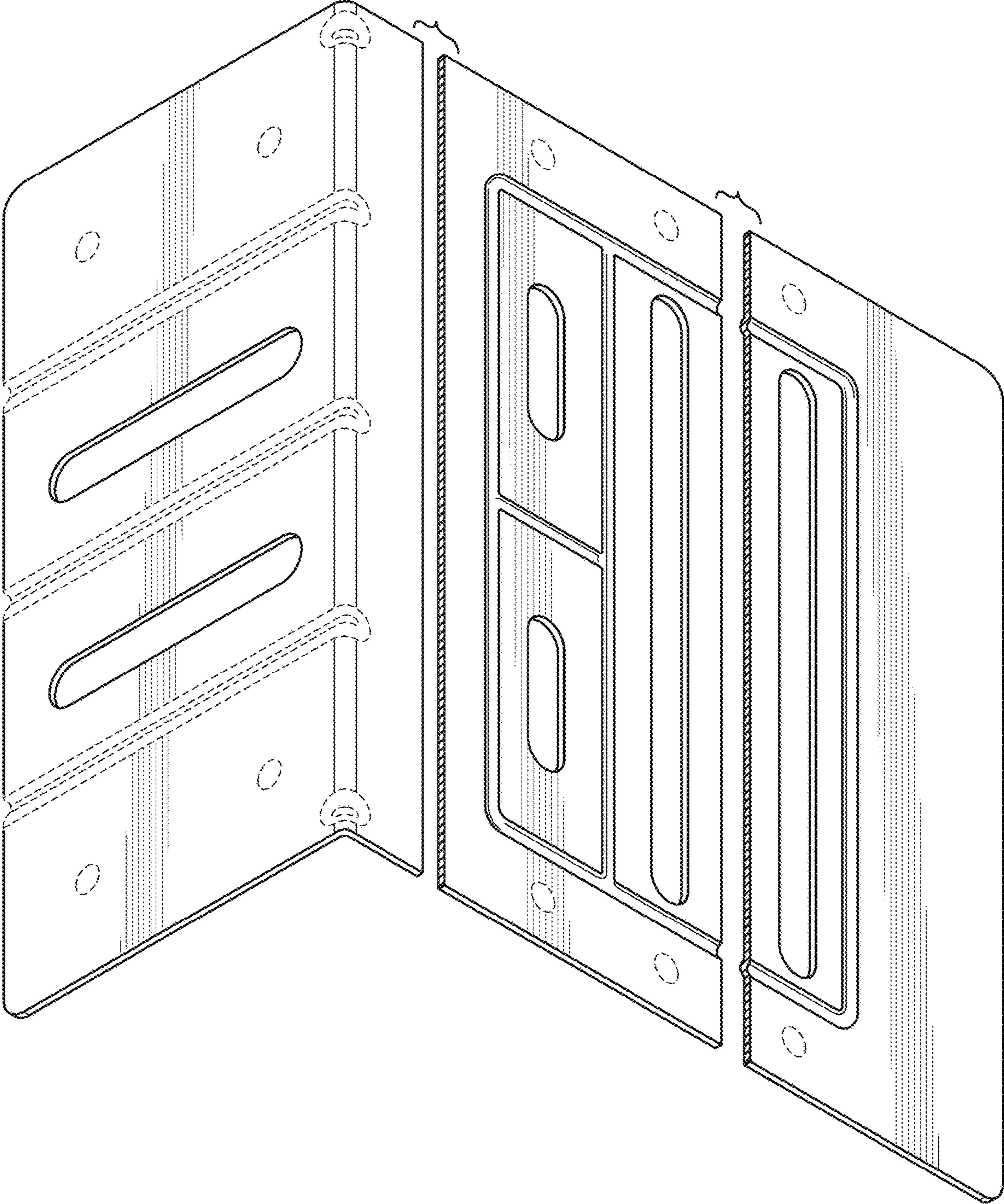

FIG. 2



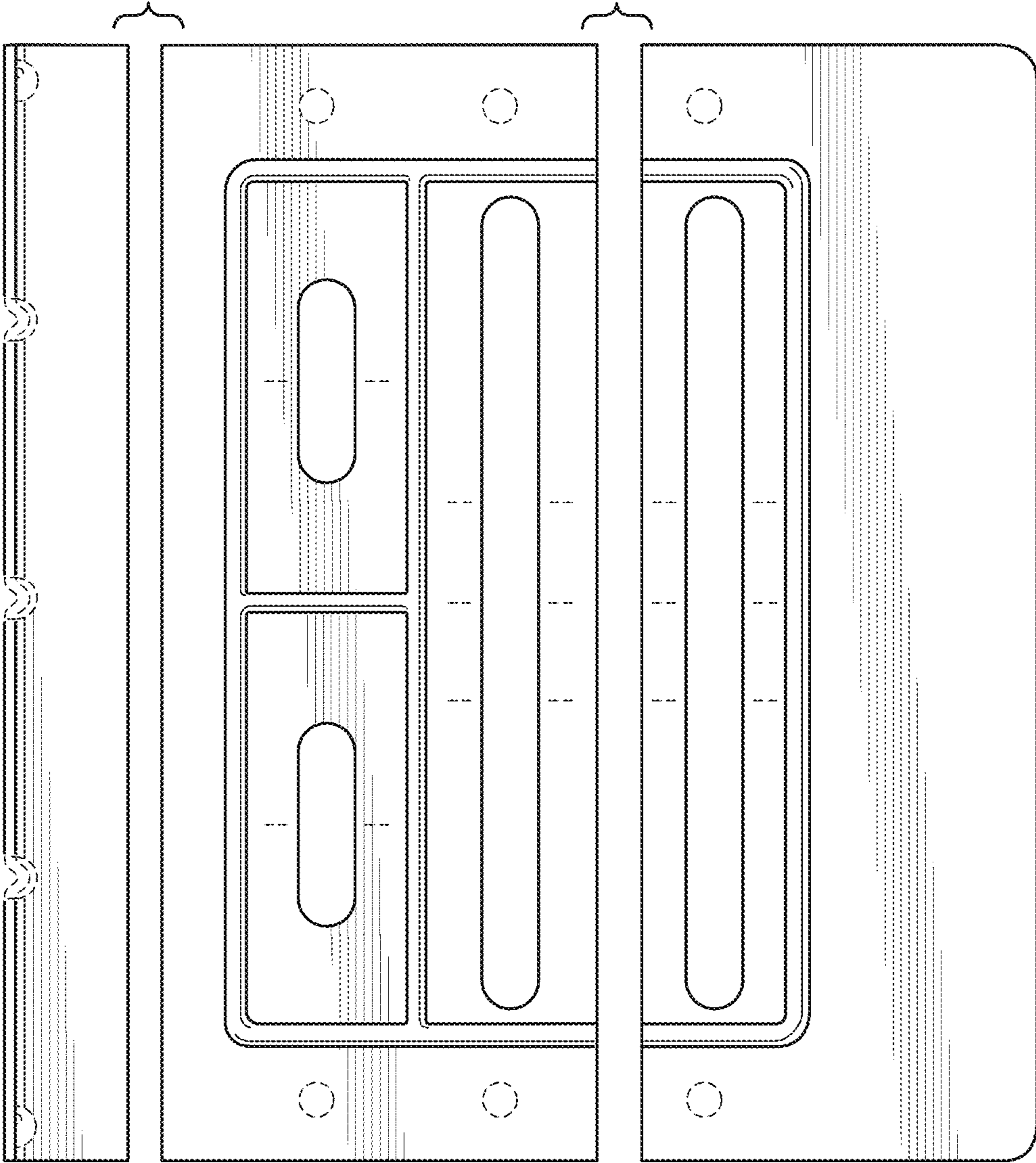

FIG. 3

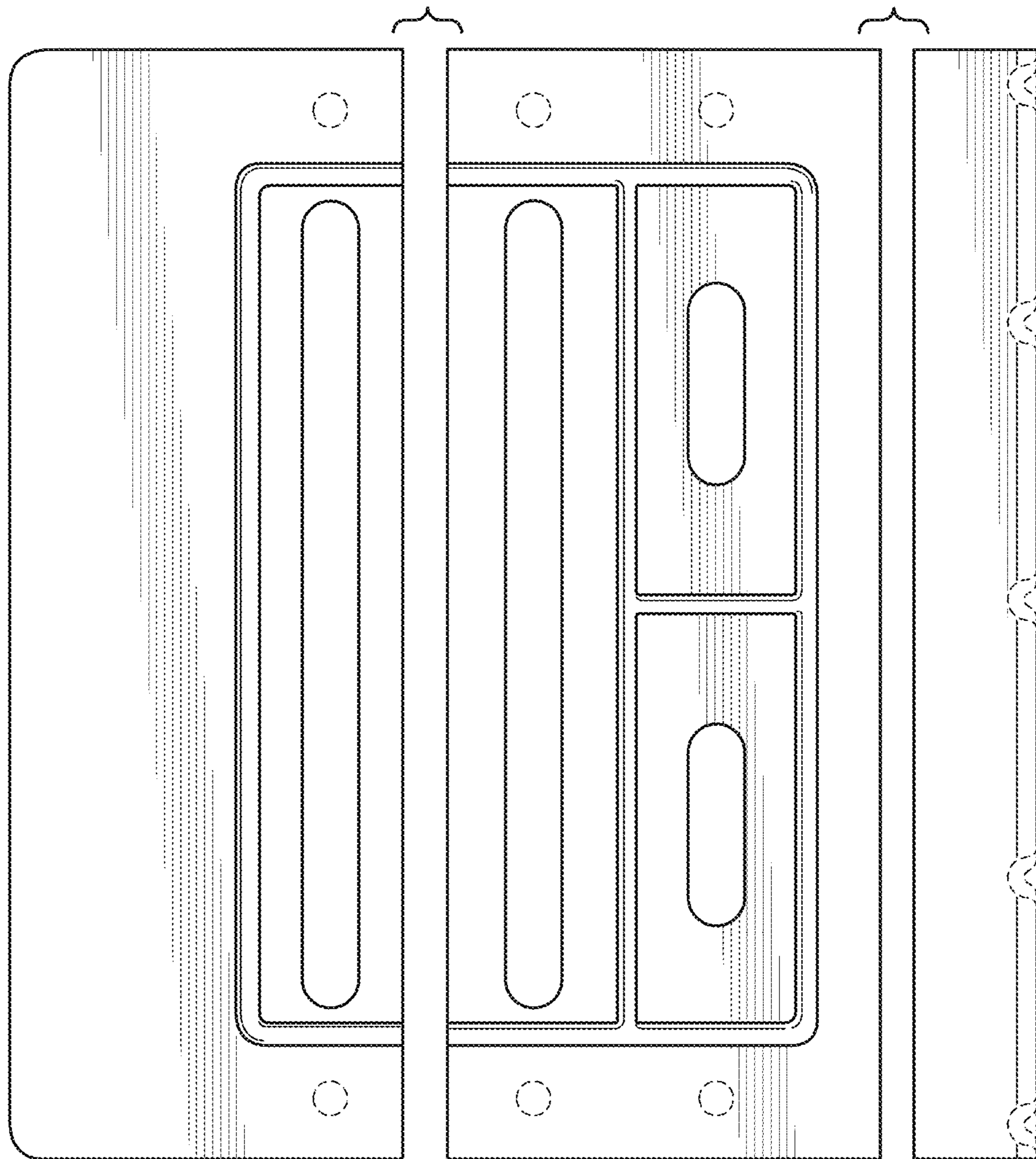
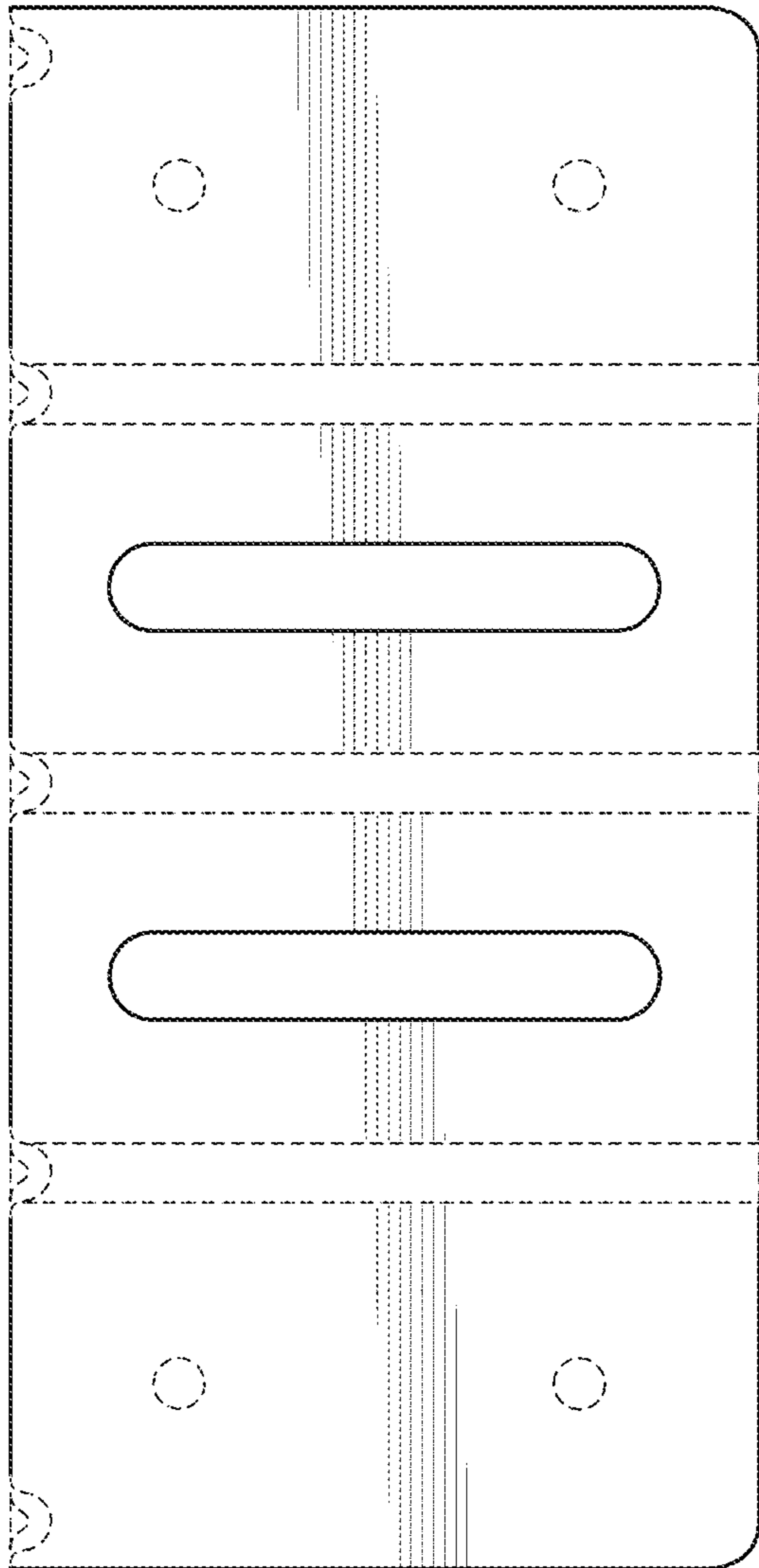
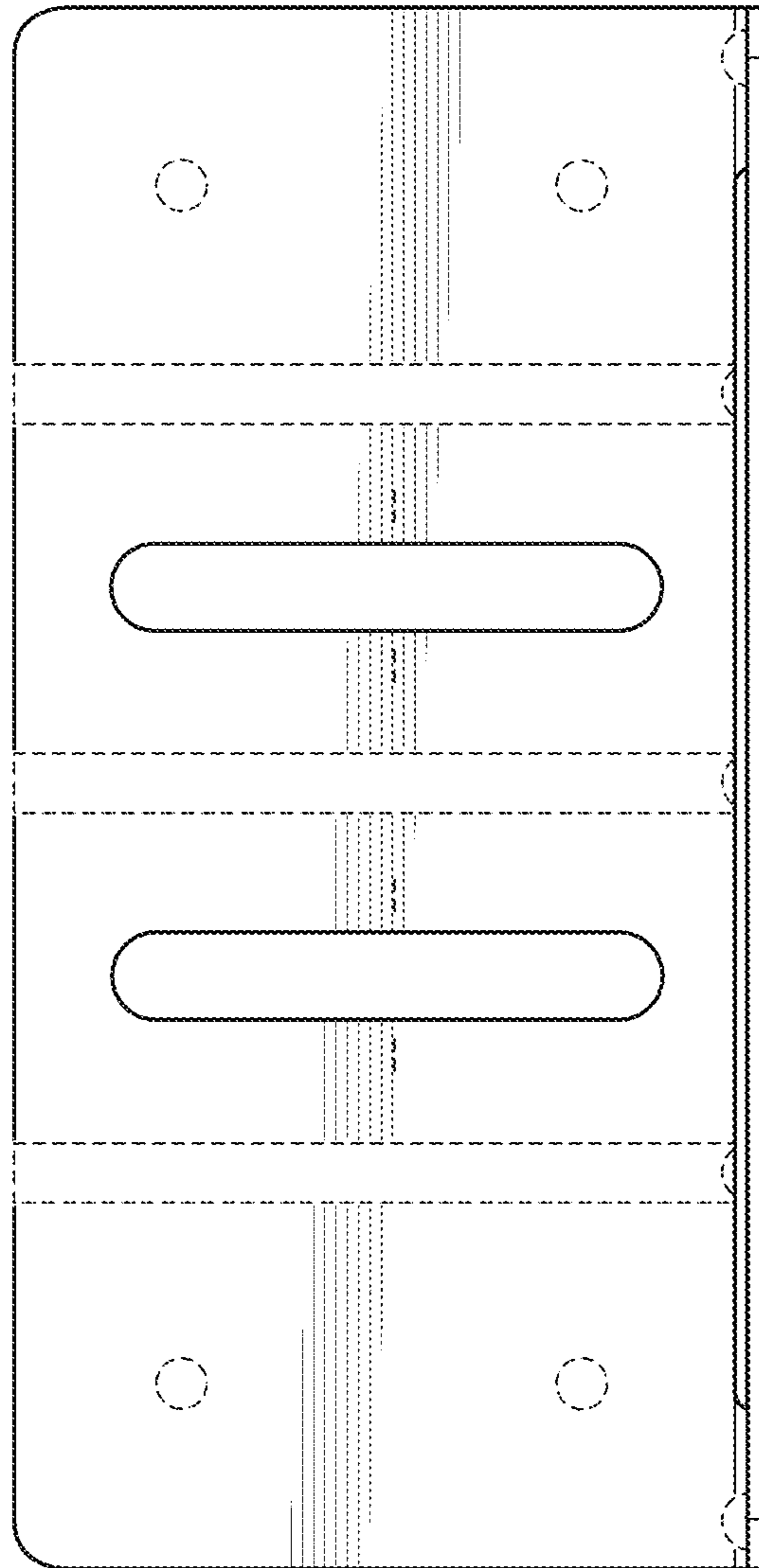

FIG. 4





**FIG. 5**



**FIG. 6**

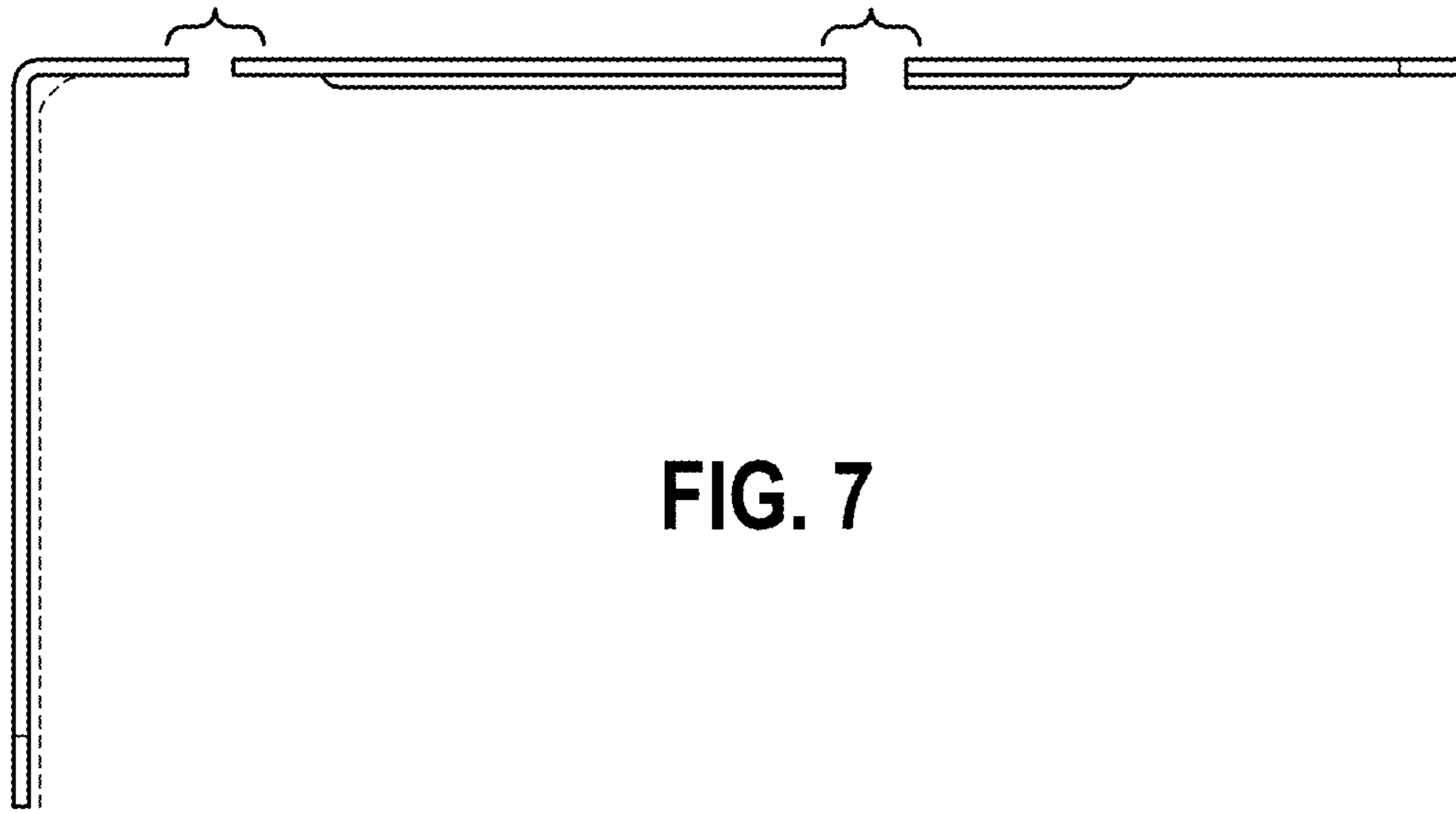

FIG. 7

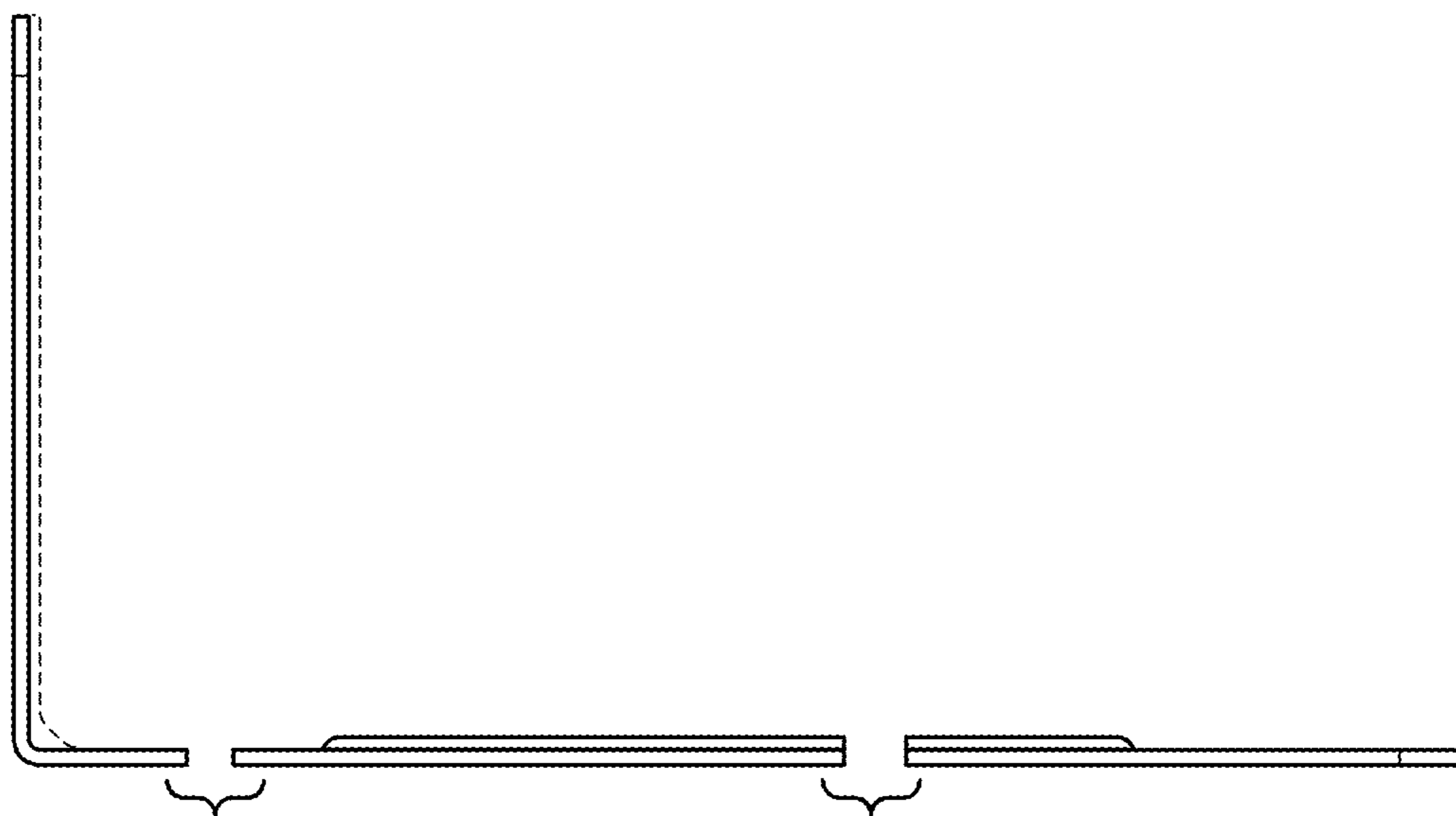

FIG. 8



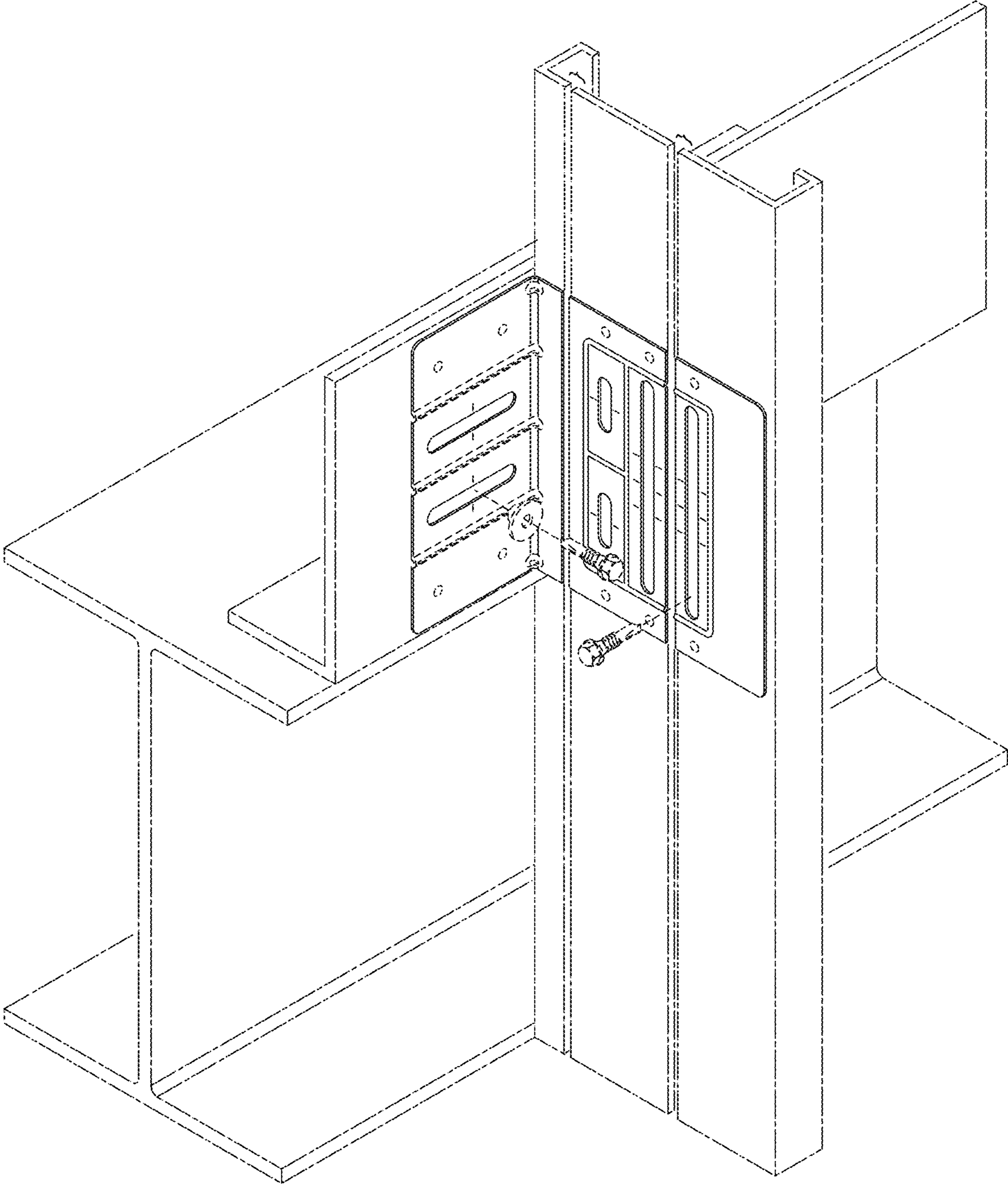

FIG. 9

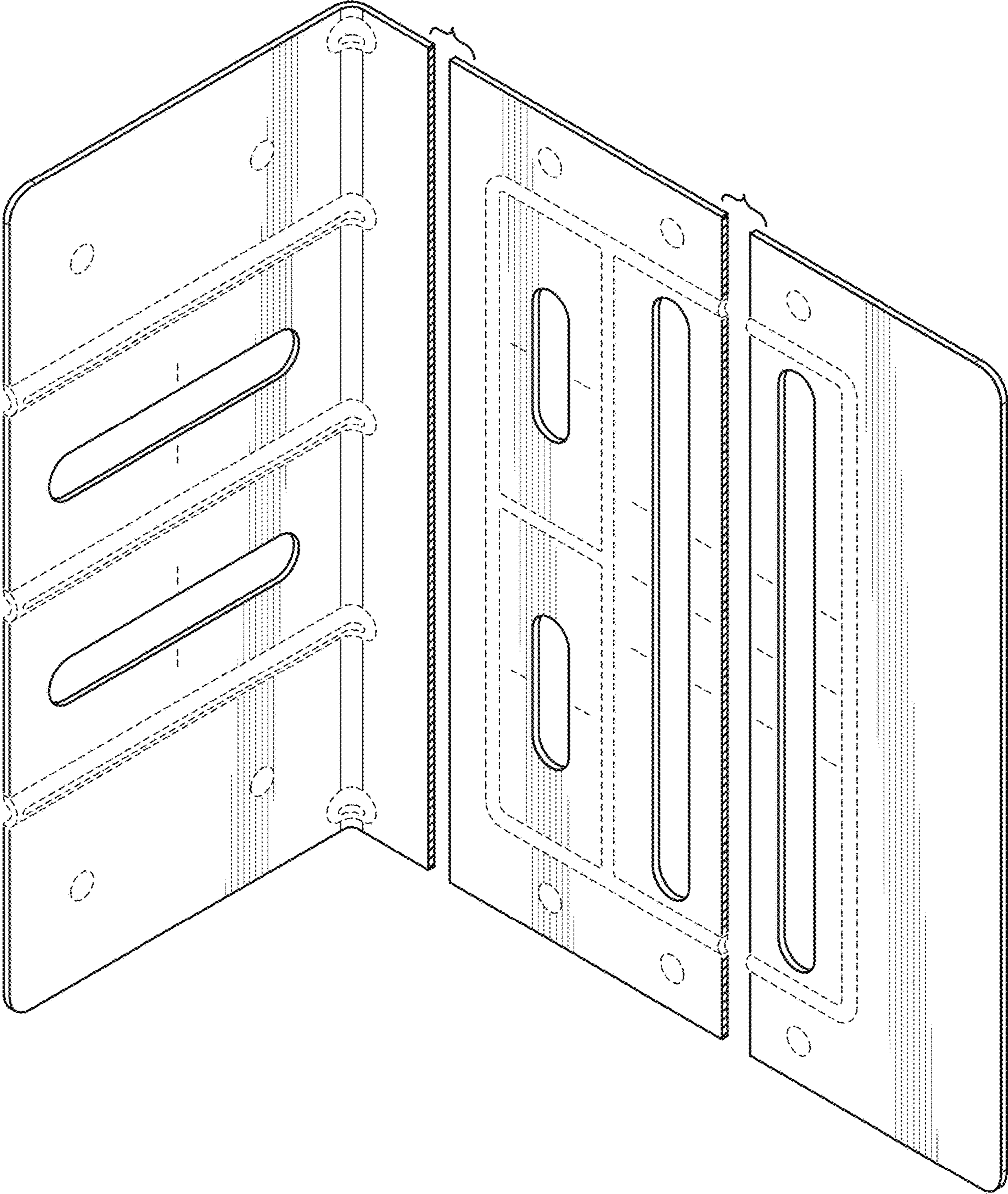

FIG. 10



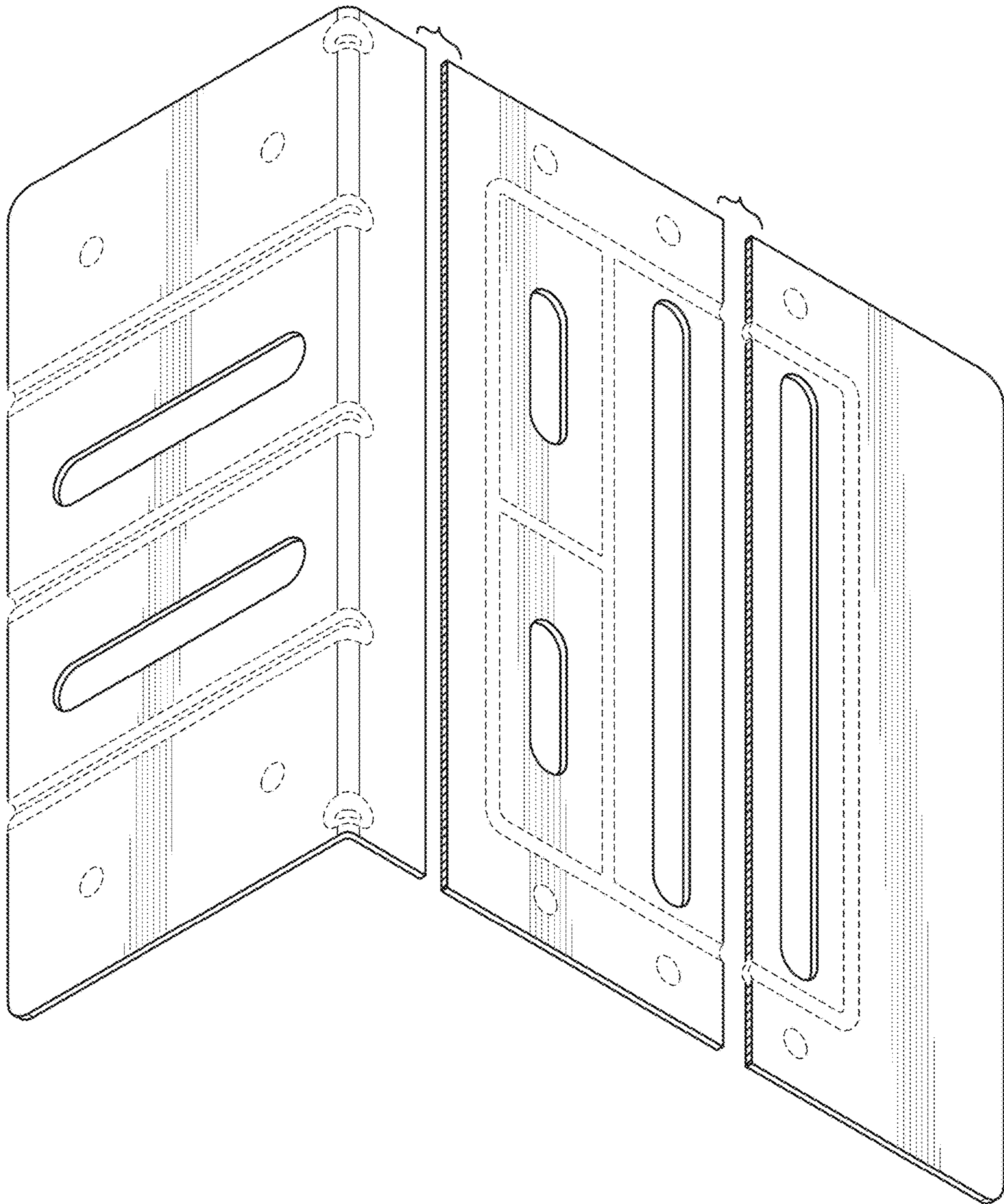

FIG. 11

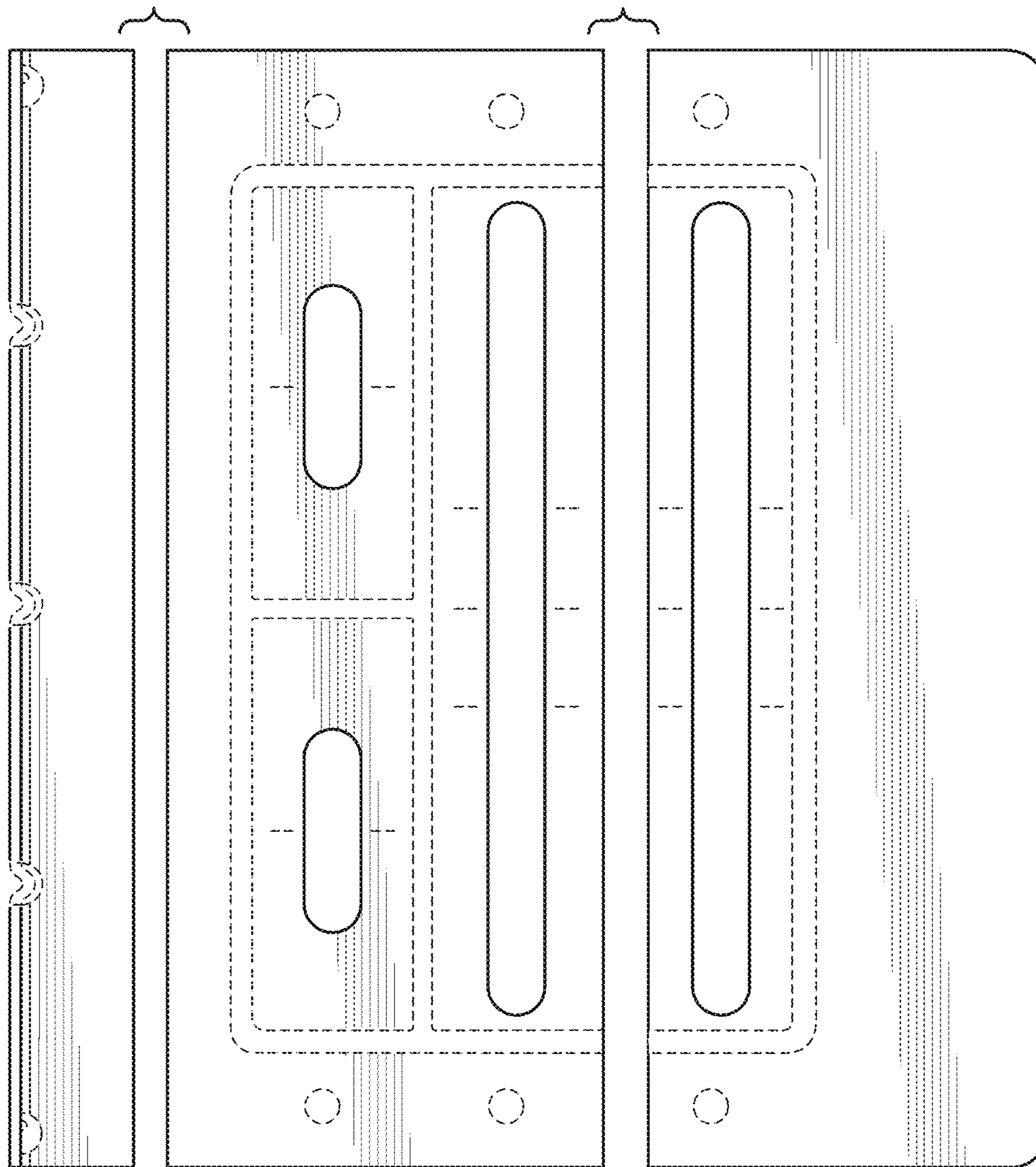

FIG. 12



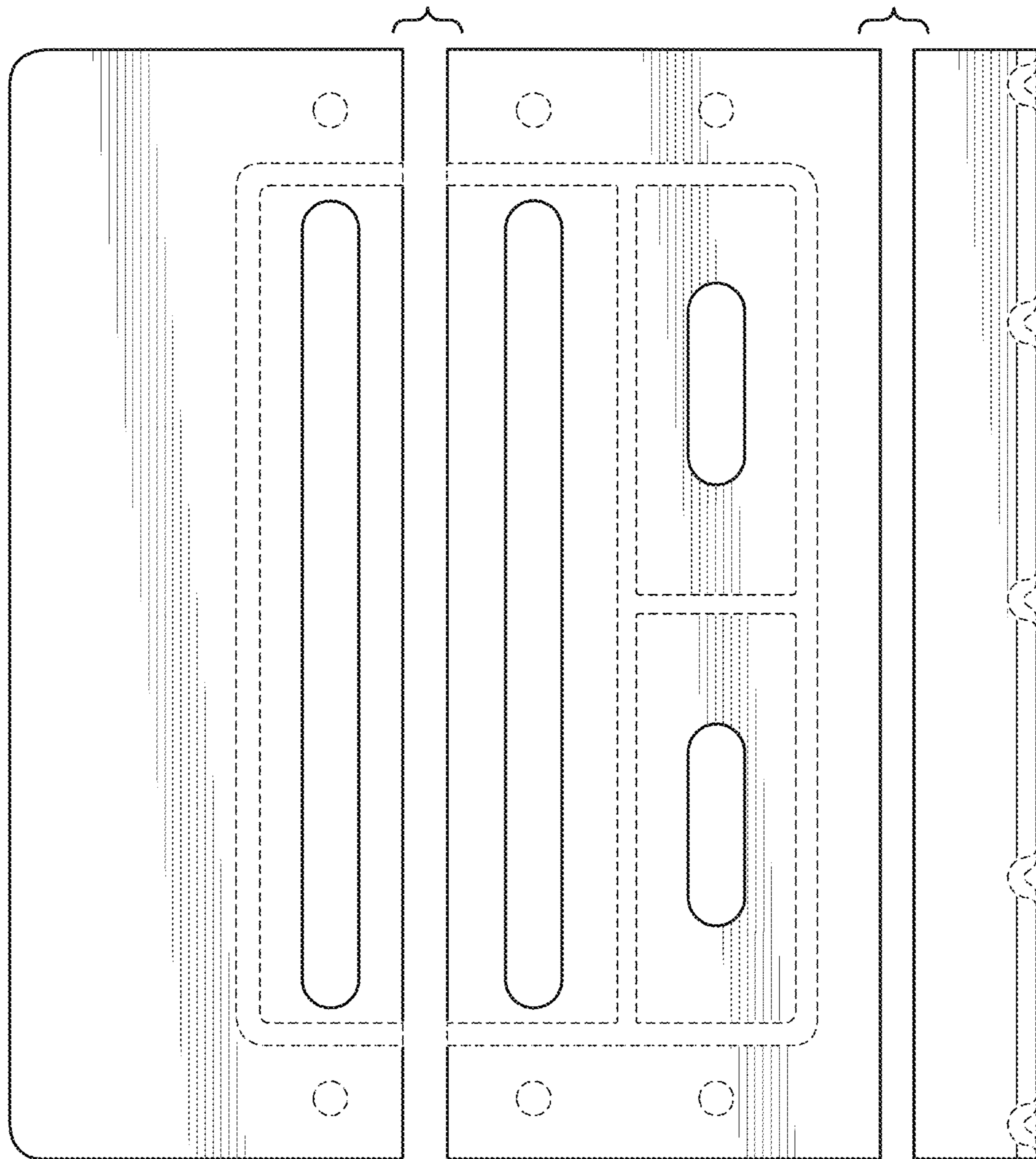
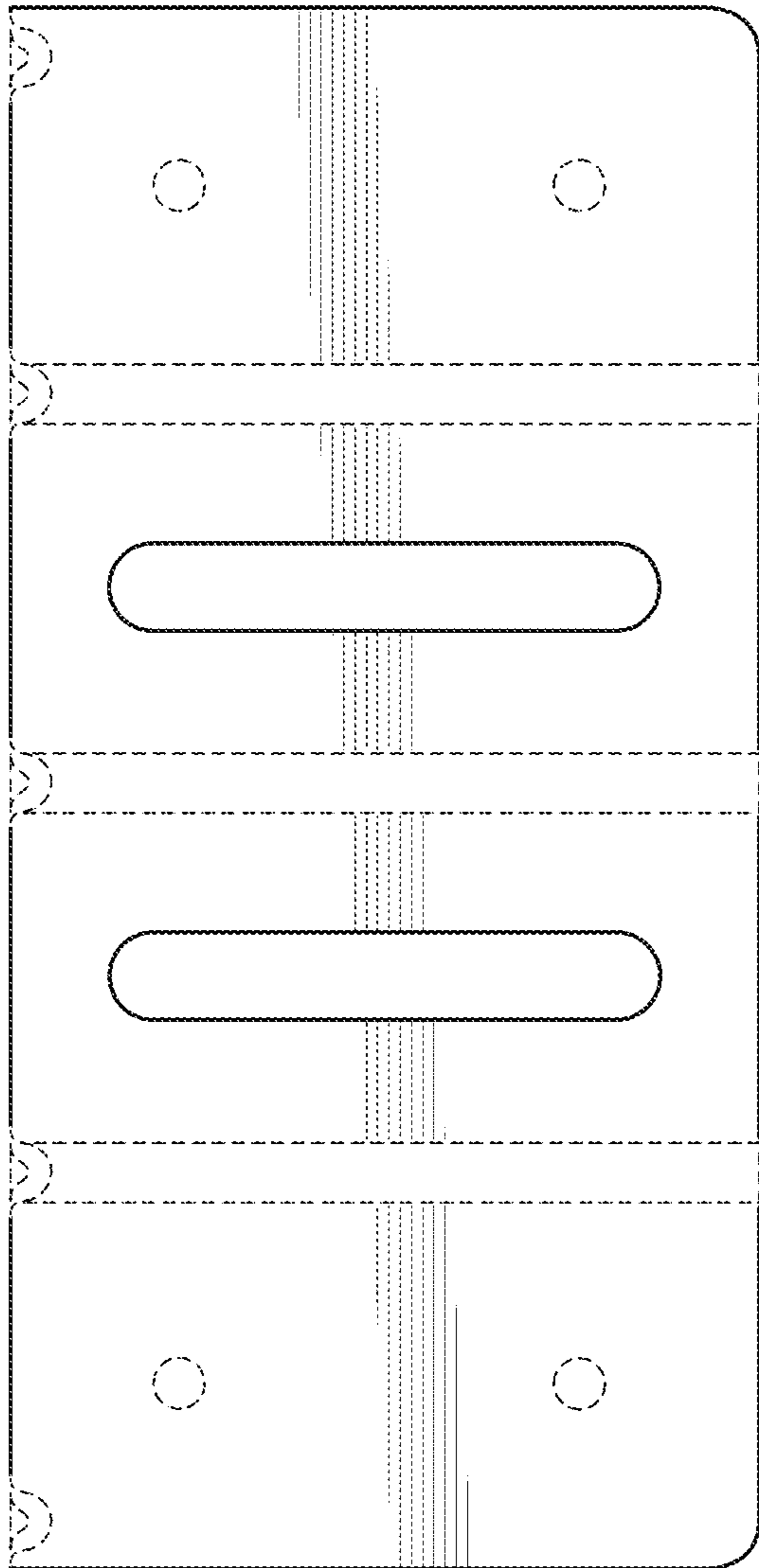
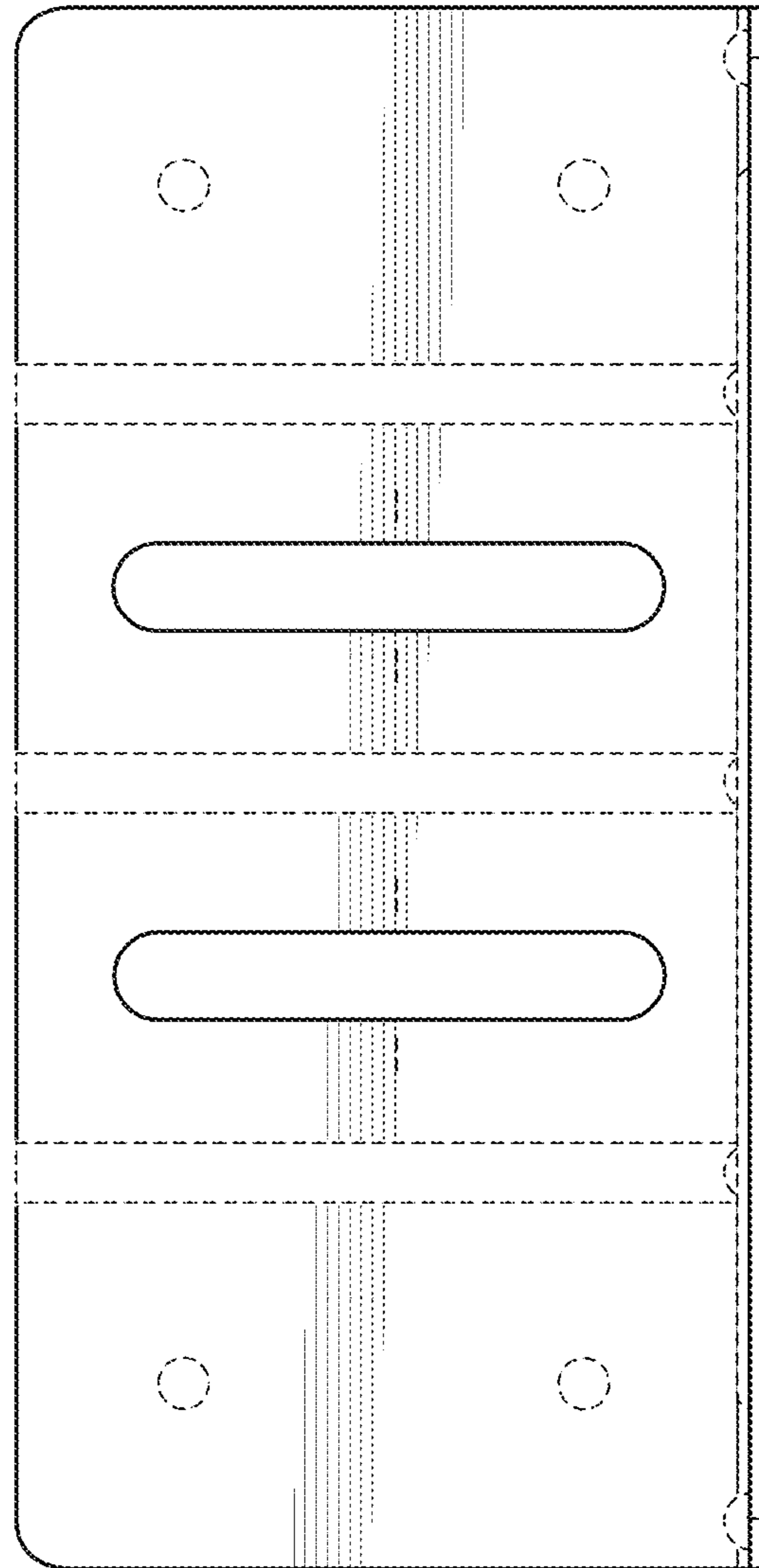

FIG. 13

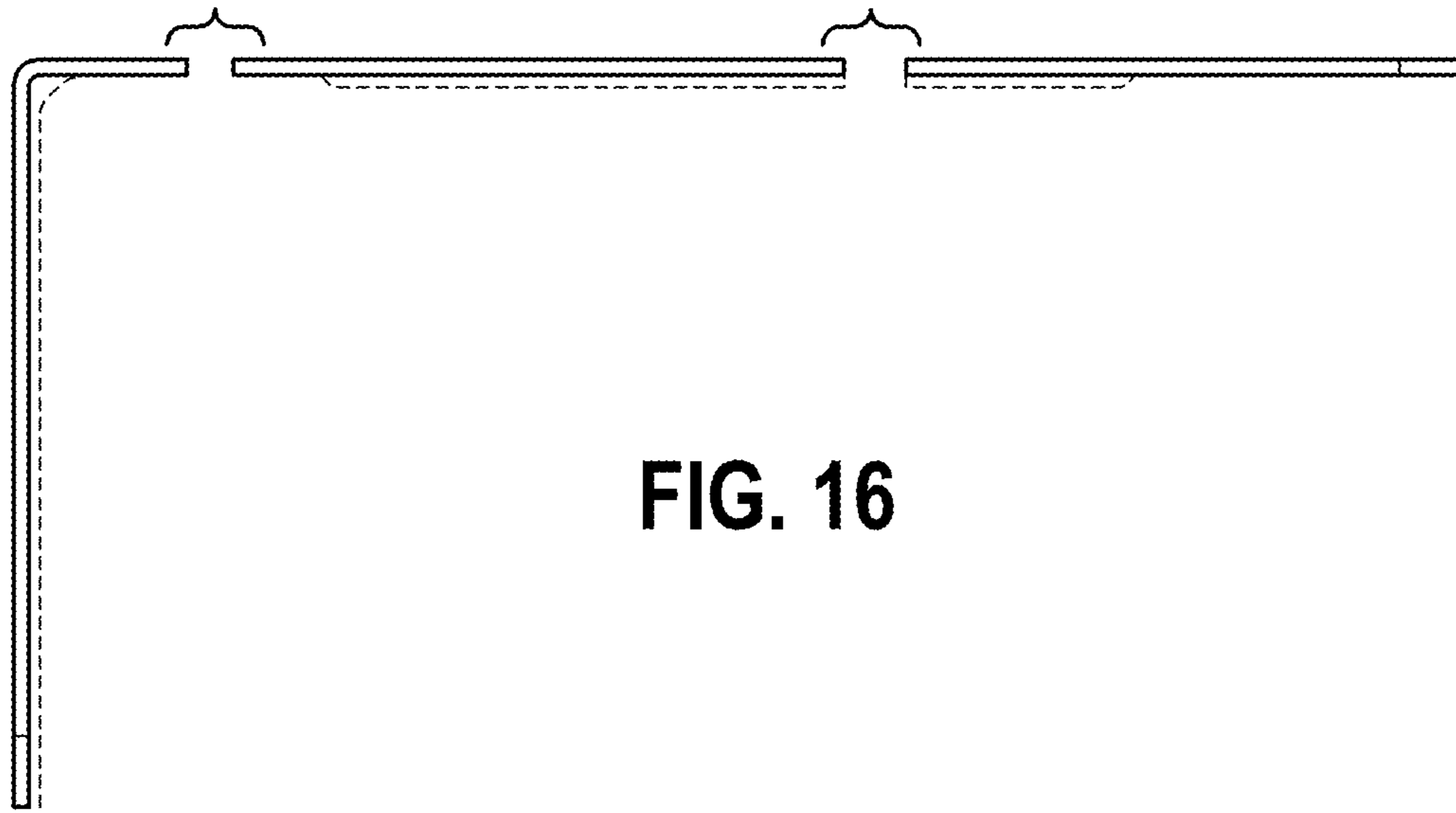

**FIG. 14**

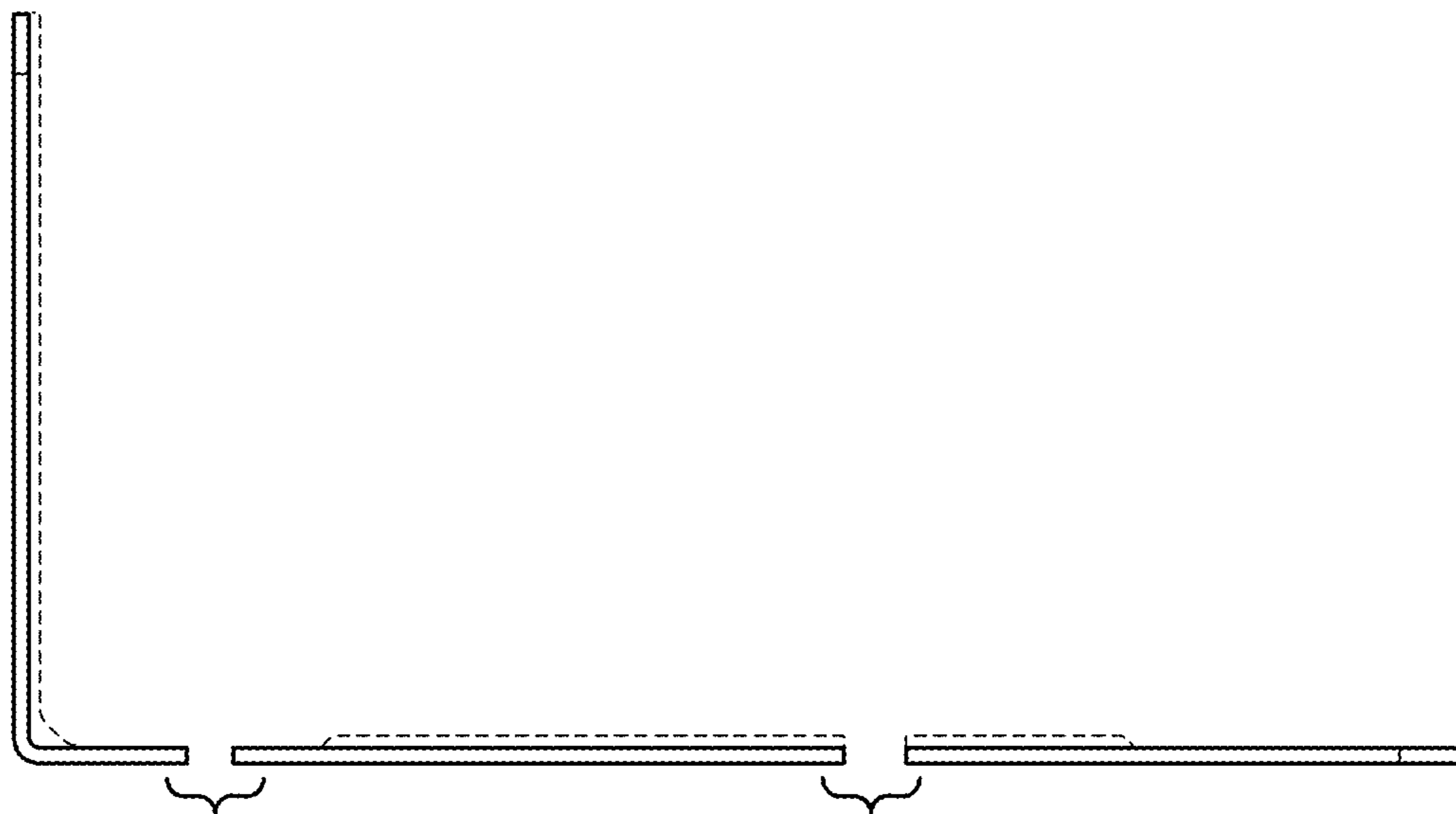

**FIG. 15**





**FIG. 16**



**FIG. 17**

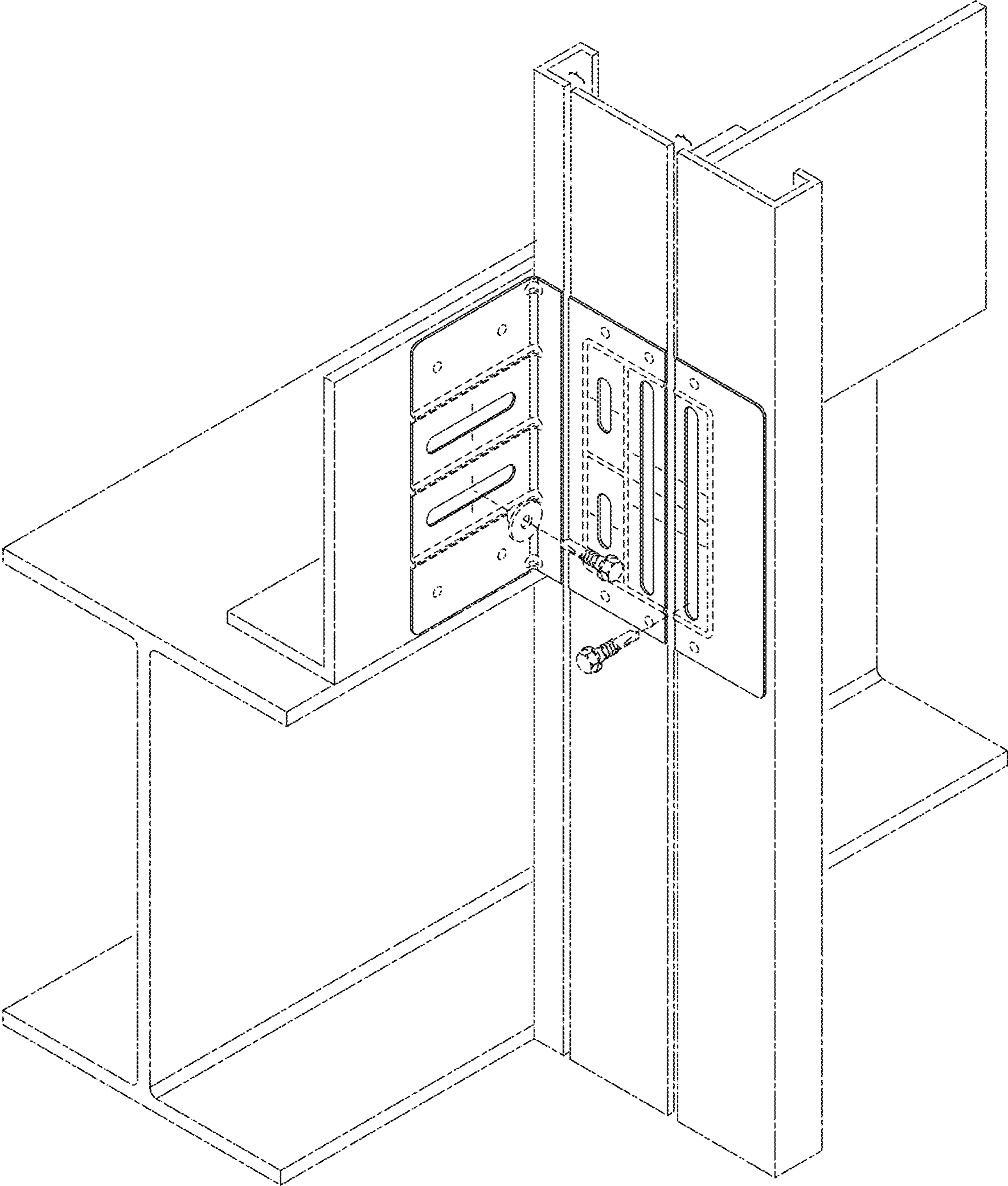

FIG. 18