



US00D958862S

(12) **United States Design Patent** (10) **Patent No.:** **US D958,862 S**
Li (45) **Date of Patent:** **** Jul. 26, 2022**

(54) **MOBILE ROBOT**
(71) Applicant: **Fuzhi Technology (Shenzhen) Co., Ltd., Shenzhen (CN)**
(72) Inventor: **Jialin Li, Shenzhen (CN)**
(73) Assignee: **Fuzhi Technology (Shenzhen) Co., Ltd., Shenzhen (CN)**
(**) Term: **15 Years**
(21) Appl. No.: **29/772,431**
(22) Filed: **Mar. 2, 2021**
(51) **LOC (13) Cl.** **15-99**
(52) **U.S. Cl.**
USPC **D15/199**
(58) **Field of Classification Search**
USPC D15/199; D21/578-583, 621, 622;
D32/21; D34/34
CPC B25J 5/007; B25J 11/00; B25J 11/008;
B62D 57/024; G06N 3/008; Y10S 901/01
See application file for complete search history.

(56) **References Cited**

U.S. PATENT DOCUMENTS

D450,788 S *	11/2001	Kawasaki	D21/578
D624,610 S *	9/2010	Wu	D21/578
D635,603 S *	4/2011	Paz Rodriguez	D15/199
D710,953 S *	8/2014	Katsutani	D15/199
D797,829 S *	9/2017	Lv	D14/154
D809,040 S *	1/2018	Webb, II	D15/199
D813,926 S *	3/2018	Shin	D16/203
D814,542 S *	4/2018	Iijima	D15/199
D830,436 S *	10/2018	Xu	D15/199
D836,690 S *	12/2018	Kim	D15/199
D837,854 S *	1/2019	Zhou	D15/199
D838,758 S *	1/2019	Kymm	D21/578
D840,618 S *	2/2019	Kim	A47J 37/0713 D15/199

D840,619 S *	2/2019	Kim	A47J 37/0713 D15/199
D840,620 S *	2/2019	Kim	D15/199
D841,711 S *	2/2019	Liu	D15/199
D843,498 S *	3/2019	Clerc	D15/199
D846,663 S *	4/2019	Guo	D21/578
D852,861 S *	7/2019	Lee	D15/199
D855,094 S *	7/2019	Li	D15/199
D862,550 S *	10/2019	Shu	B25J 9/044 D15/199
D877,994 S *	3/2020	Kim	A47L 5/30 D15/199
D878,490 S *	3/2020	Hayashi	D21/578
D879,853 S *	3/2020	Baba	D15/199
D881,250 S *	4/2020	Yao	D15/199
D890,024 S *	7/2020	Schnapp	D12/1
D893,572 S *	8/2020	Kim	D15/199
D909,495 S *	2/2021	Lee	D21/578
D912,114 S *	3/2021	Reichert	D15/199
D913,351 S *	3/2021	Ekmekjian	D12/1

(Continued)

Primary Examiner — Patricia A Palasik
(74) *Attorney, Agent, or Firm* — True Shepherd LLC;
Andrew C. Cheng

(57) **CLAIM**

The ornamental design for mobile robot, as shown and described.

DESCRIPTION

FIG. 1 is a perspective view of a mobile robot showing my new design;
FIG. 2 is a front view thereof;
FIG. 3 is a rear view thereof;
FIG. 4 is a left side view thereof;
FIG. 5 is a right side view thereof;
FIG. 6 is a top plan view thereof; and,
FIG. 7 is a bottom plan view thereof.
The broken lines depict portions of the mobile robot and form no part of the claimed design.

1 Claim, 7 Drawing Sheets

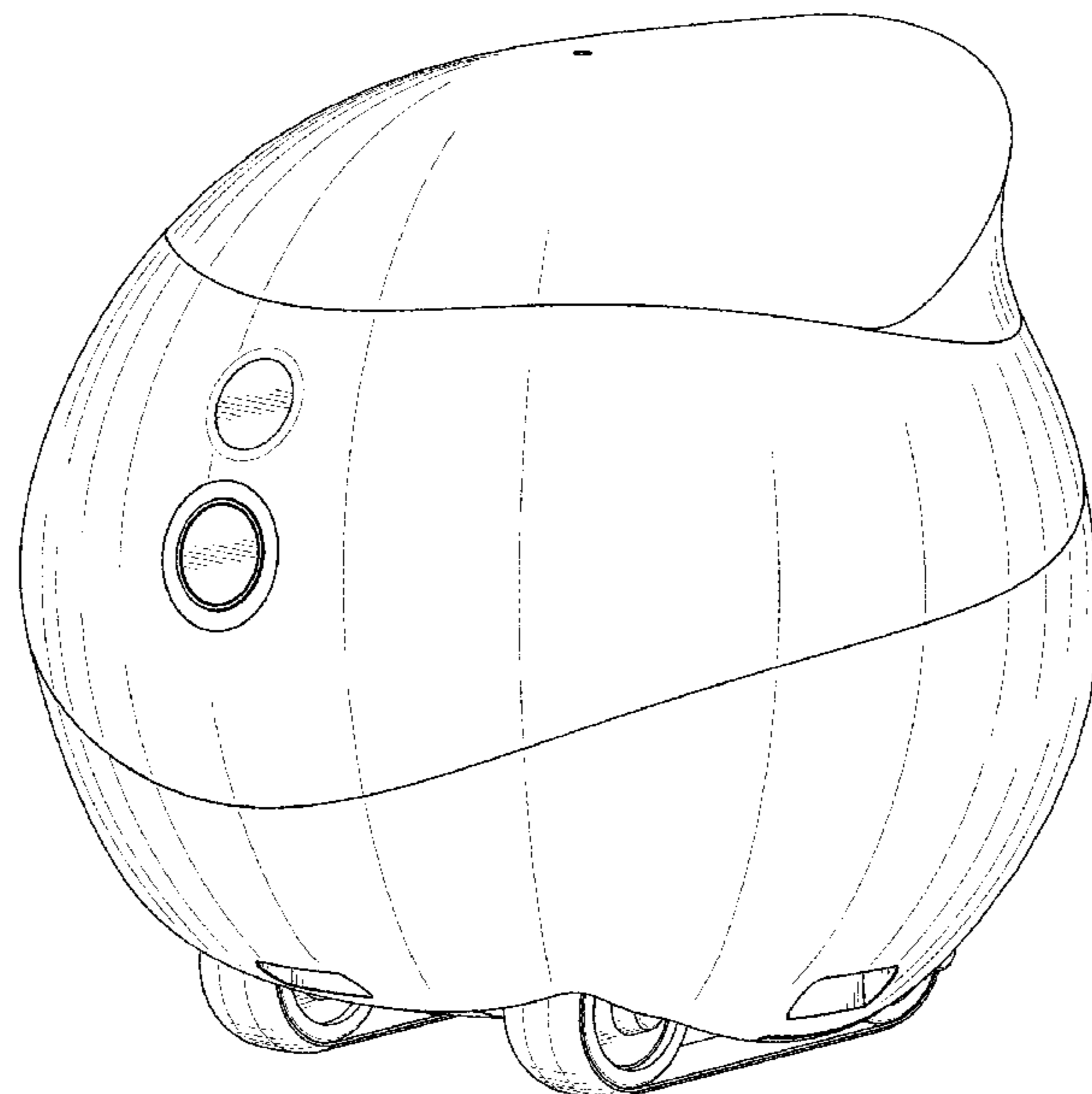

(56)

References Cited

U.S. PATENT DOCUMENTS

D923,681 S * 6/2021 Lee G05D 1/024
D15/199
D928,858 S * 8/2021 Lee D15/199
D930,058 S * 9/2021 Mahe D15/199
D930,726 S * 9/2021 Vaswani D15/199
D936,719 S * 11/2021 Mok B25J 11/009
D15/199
D941,379 S * 1/2022 Koshiishi D15/199
D944,769 S * 3/2022 Bae D14/207
2016/0346917 A1* 12/2016 Ho B25J 13/085
2017/0136631 A1* 5/2017 Li G06N 20/00

* cited by examiner

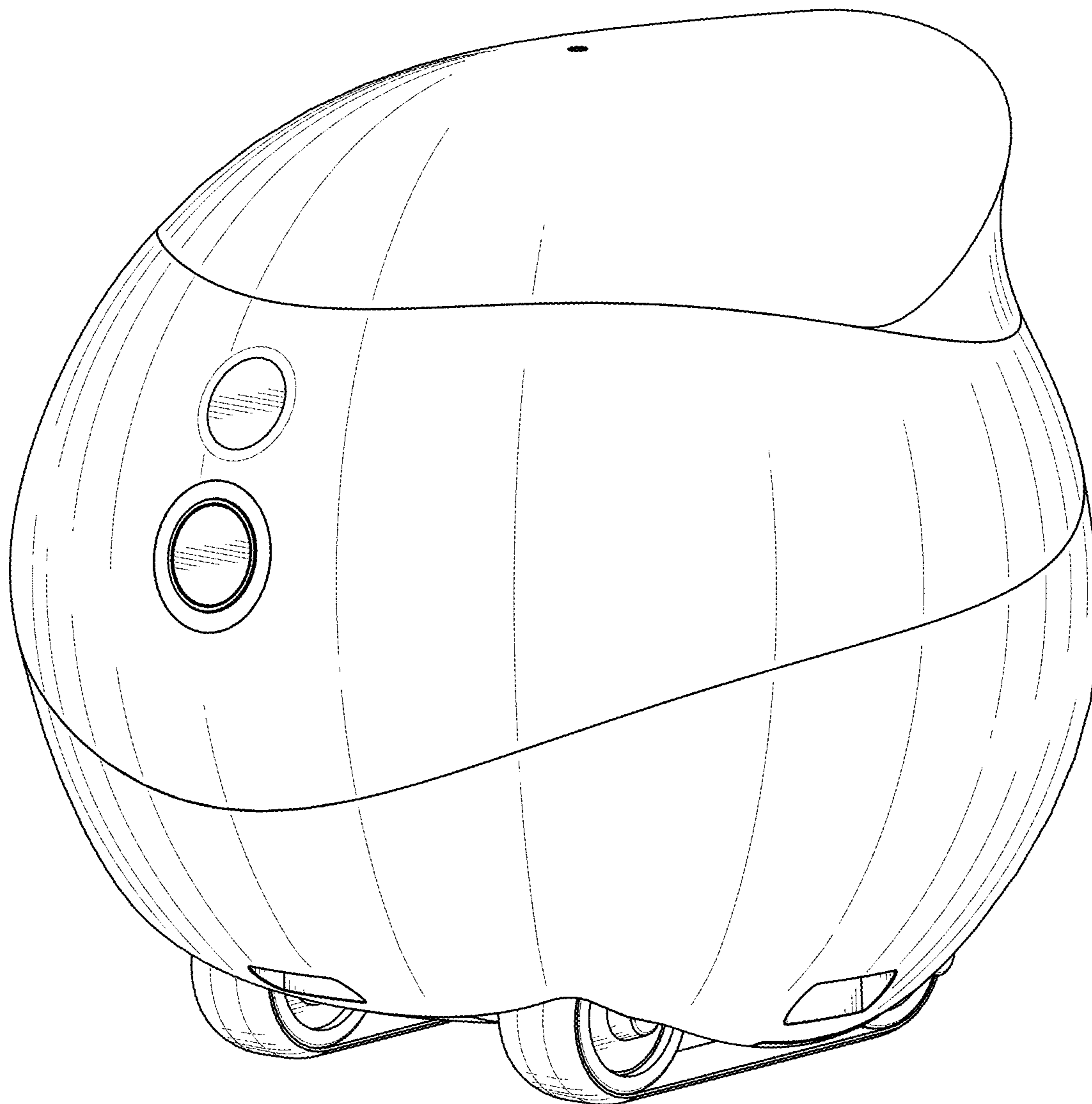

FIG. 1

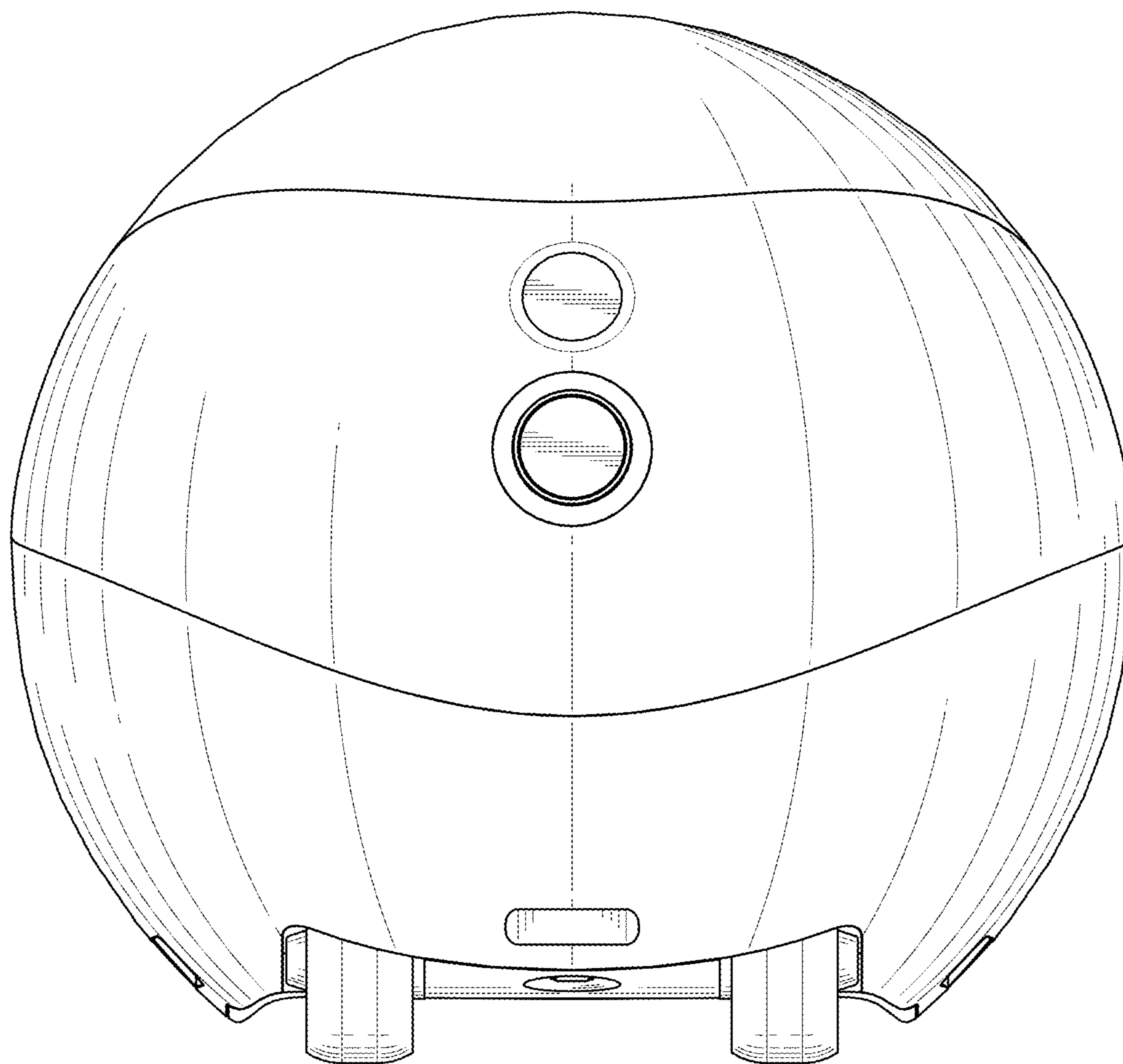

FIG. 2

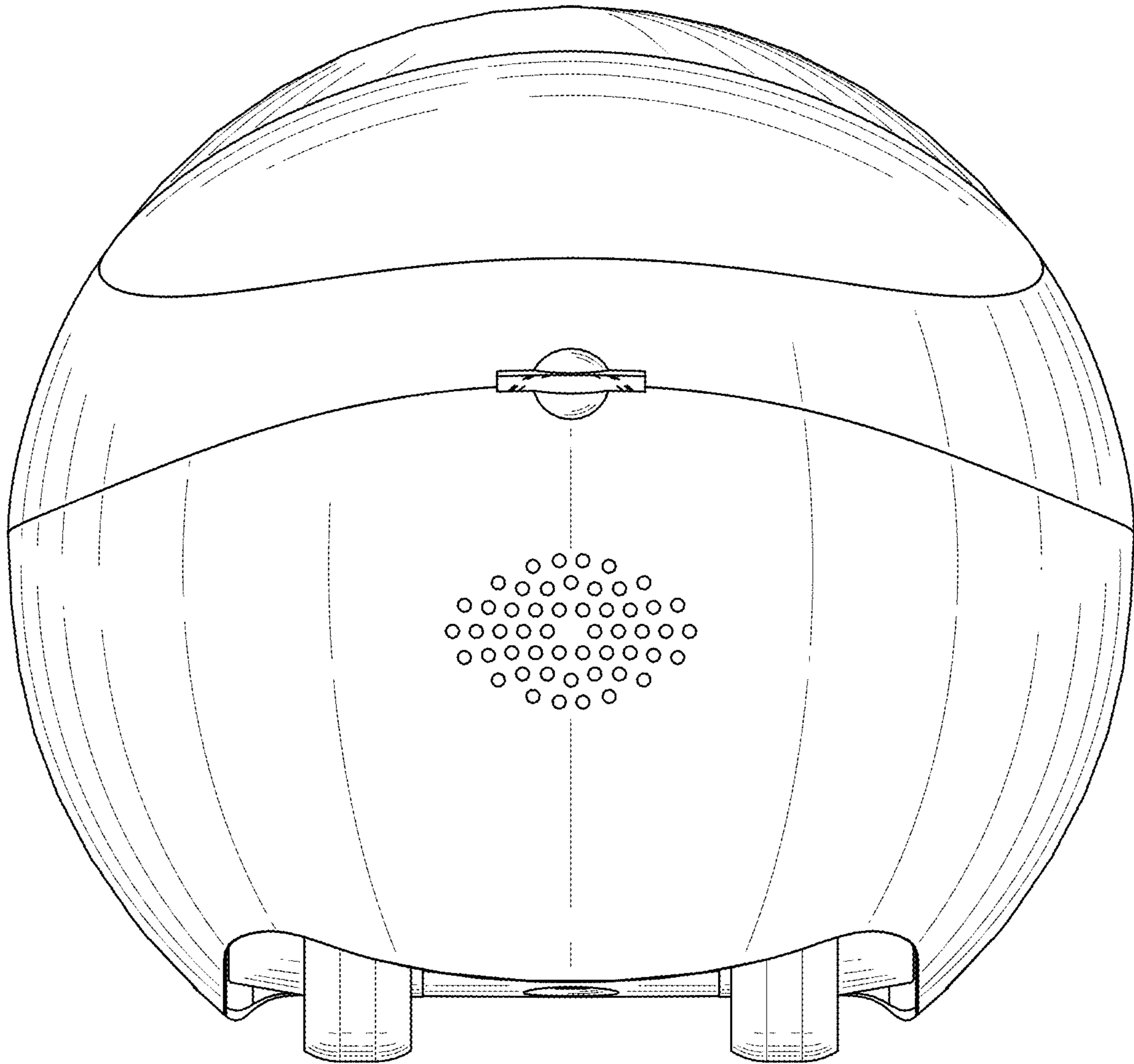

FIG. 3

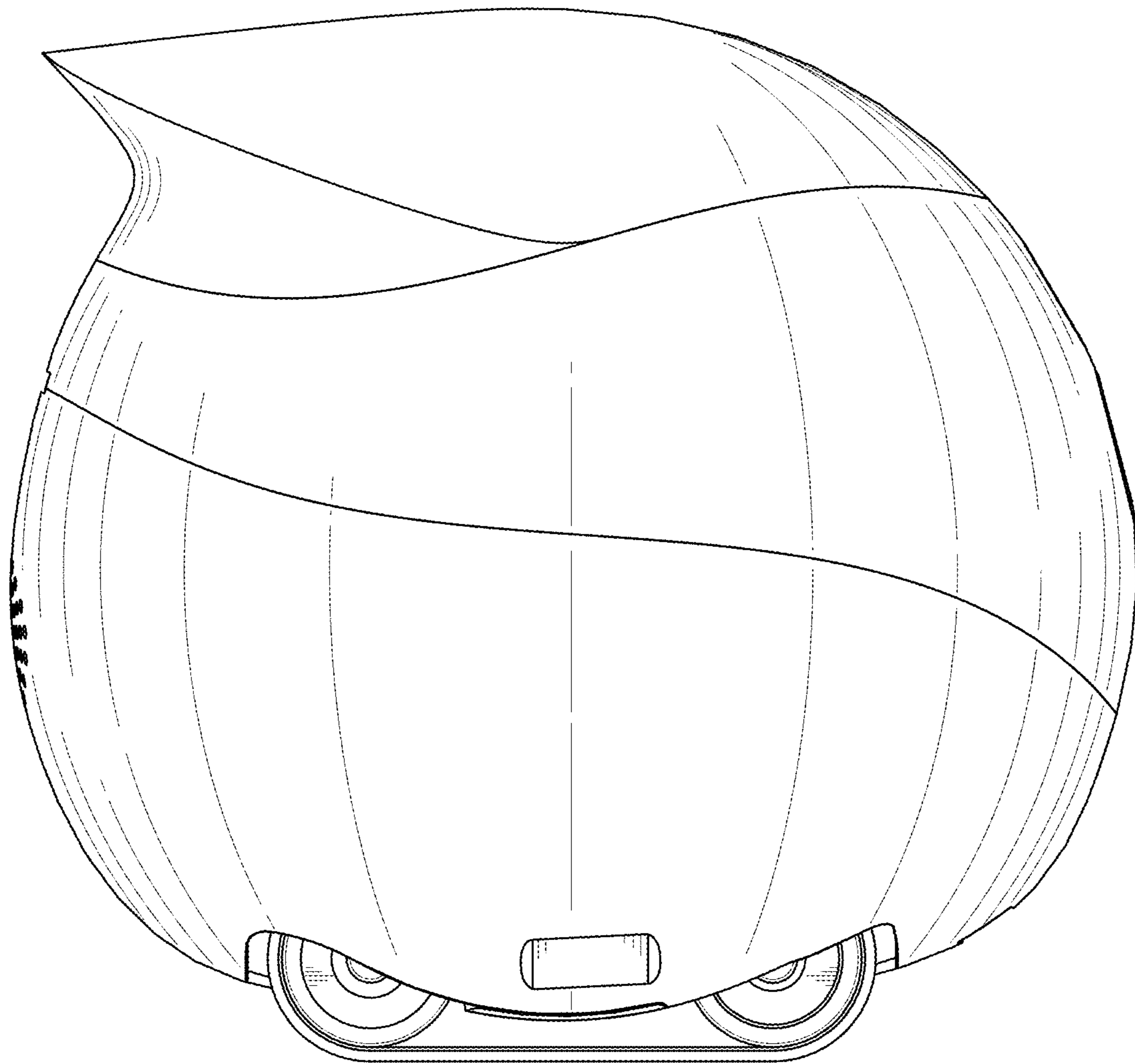

FIG. 4

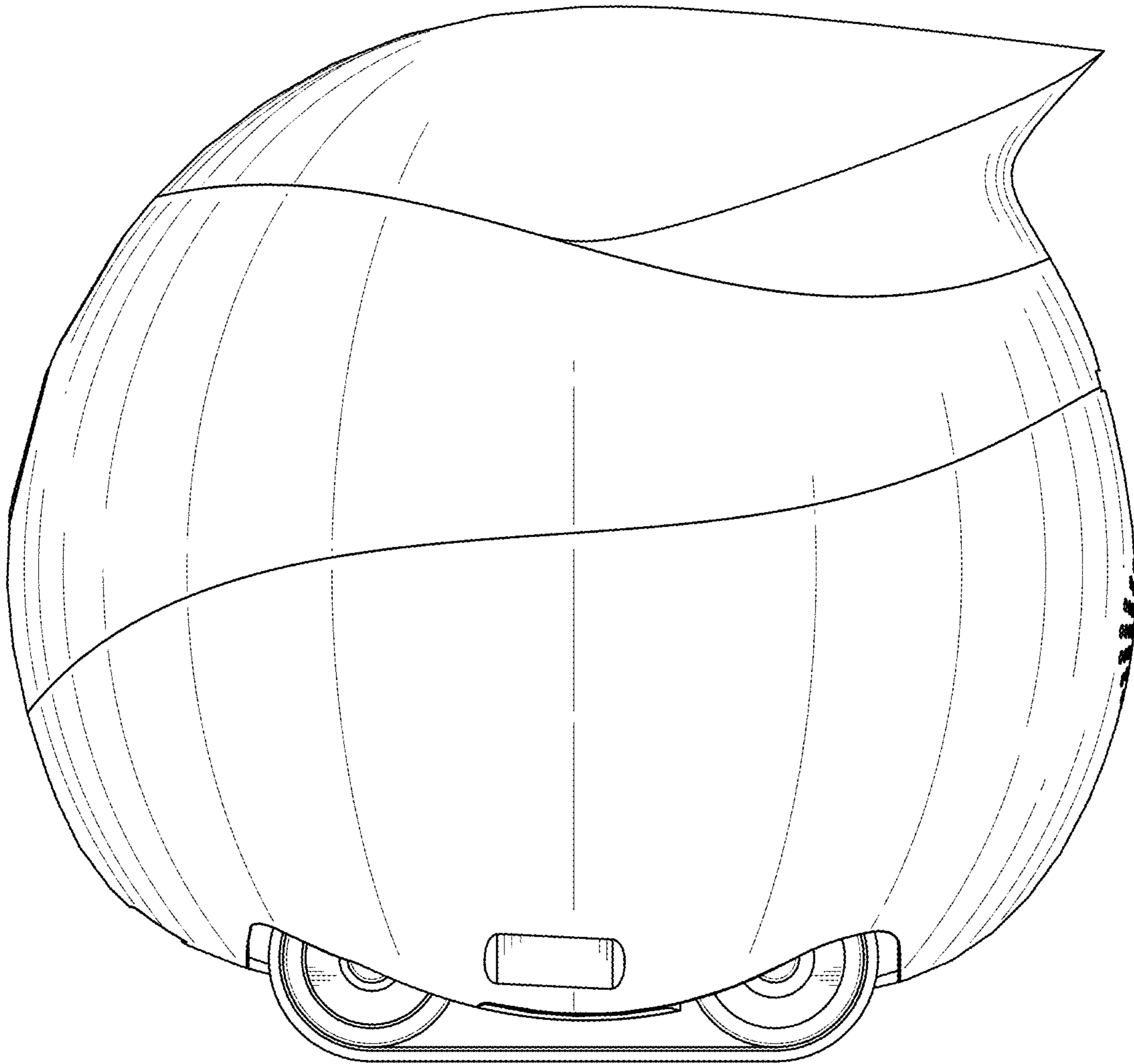

FIG. 5

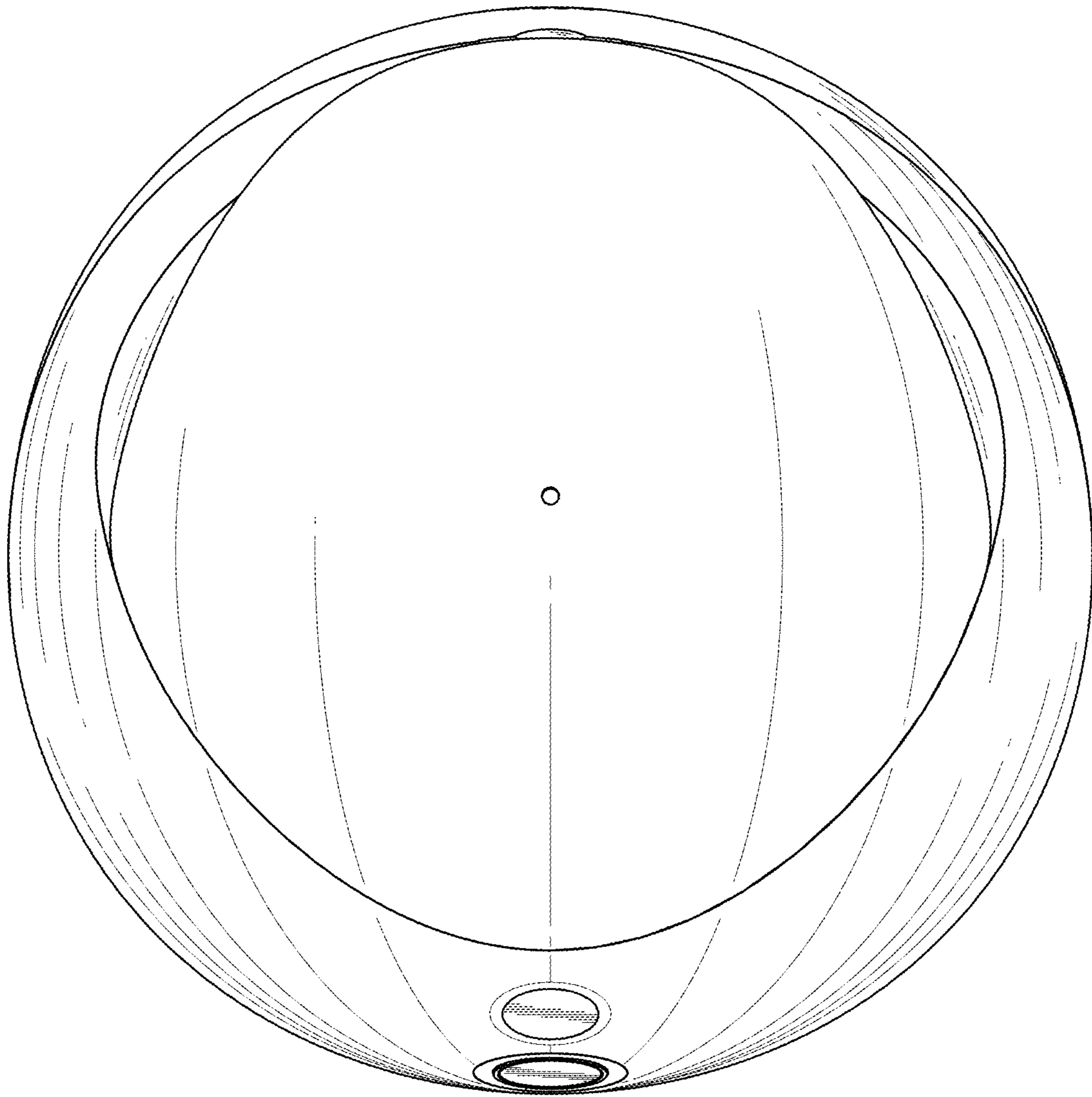

FIG. 6

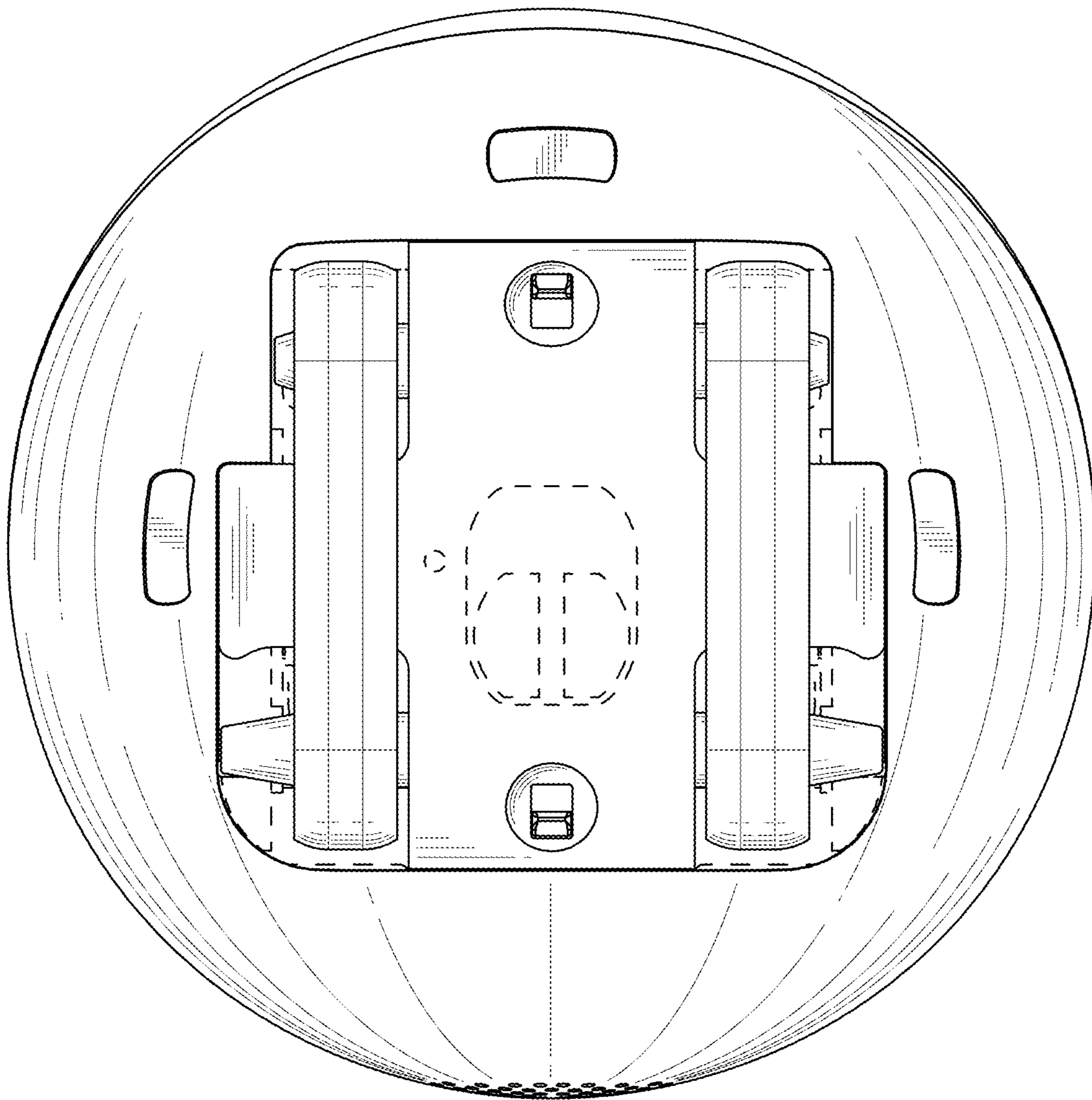

FIG. 7