



US00D958222S

(12) **United States Design Patent**
Fan

(10) **Patent No.:** **US D958,222 S**
(45) **Date of Patent:** **** Jul. 19, 2022**

(54) **360 PHOTO BOOTH**

(71) Applicant: **Chengdu Tops Technology Co., Ltd.**,
Chengdu (CN)

(72) Inventor: **Xing Fan**, Nanchong (CN)

(**) Term: **15 Years**

(21) Appl. No.: **29/816,741**

(22) Filed: **Nov. 24, 2021**

(30) **Foreign Application Priority Data**

Oct. 25, 2021 (CN) 202130696288.1

(51) **LOC (13) Cl.** **16-01**

(52) **U.S. Cl.**
USPC **D16/215**

(58) **Field of Classification Search**

USPC D16/200, 202–204, 208, 211, 218, 219,
D16/221, 225, 229, 232, 242; D14/423;
348/373–376; 396/430, 431, 535,
396/539–541

CPC G03B 17/02; G03B 19/04; G03B 17/56;
G03B 17/04; G03B 15/03; G03B 17/48;
G03B 17/06; H04N 5/2251; H04N
5/2252; H04N 5/2253; H04N 5/2254

See application file for complete search history.

(56) **References Cited**

U.S. PATENT DOCUMENTS

D569,887 S * 5/2008 Feng D16/202
D721,757 S * 1/2015 Shepard D16/214
D729,296 S * 5/2015 Shelton D16/202

D731,575 S * 6/2015 Moss D16/215
D755,876 S * 5/2016 Moss D16/214
D785,694 S * 5/2017 Fujii D16/214
D824,986 S * 8/2018 Bartram D16/202
D849,104 S * 5/2019 Wong D16/215
D860,292 S * 9/2019 Callens D16/214
D865,837 S * 11/2019 Hasegawa D16/202
D881,259 S * 4/2020 Wang D16/202
D895,712 S * 9/2020 van Schalkwyk D16/219
D898,805 S * 10/2020 Lynch et al.
D921,088 S * 6/2021 Andres D16/214

* cited by examiner

Primary Examiner — Ramzi Almatrahi

(57) **CLAIM**

The ornamental design for a 360 photo booth, substantially as shown and described.

DESCRIPTION

FIG. 1 is a top, front and right side perspective view of a 360 photo booth, showing my new design;
FIG. 2 is a bottom, rear and left side perspective view;
FIG. 3 is a front elevational view thereof;
FIG. 4 is a rear elevational view thereof;
FIG. 5 is a left side elevational view thereof;
FIG. 6 is a right side elevational view thereof;
FIG. 7 is a top plan view thereof;
FIG. 8 is a bottom plan view thereof; and,
FIG. 9 is an enlarged view of portion 9 shown in FIG. 2.
The broken lines depict portions of the 360 photo booth in which the design is embodied that form no part of the claimed design. The dot-dash broken lines encircling an enlargement portion of the design forms no part of the claimed design.

1 Claim, 9 Drawing Sheets

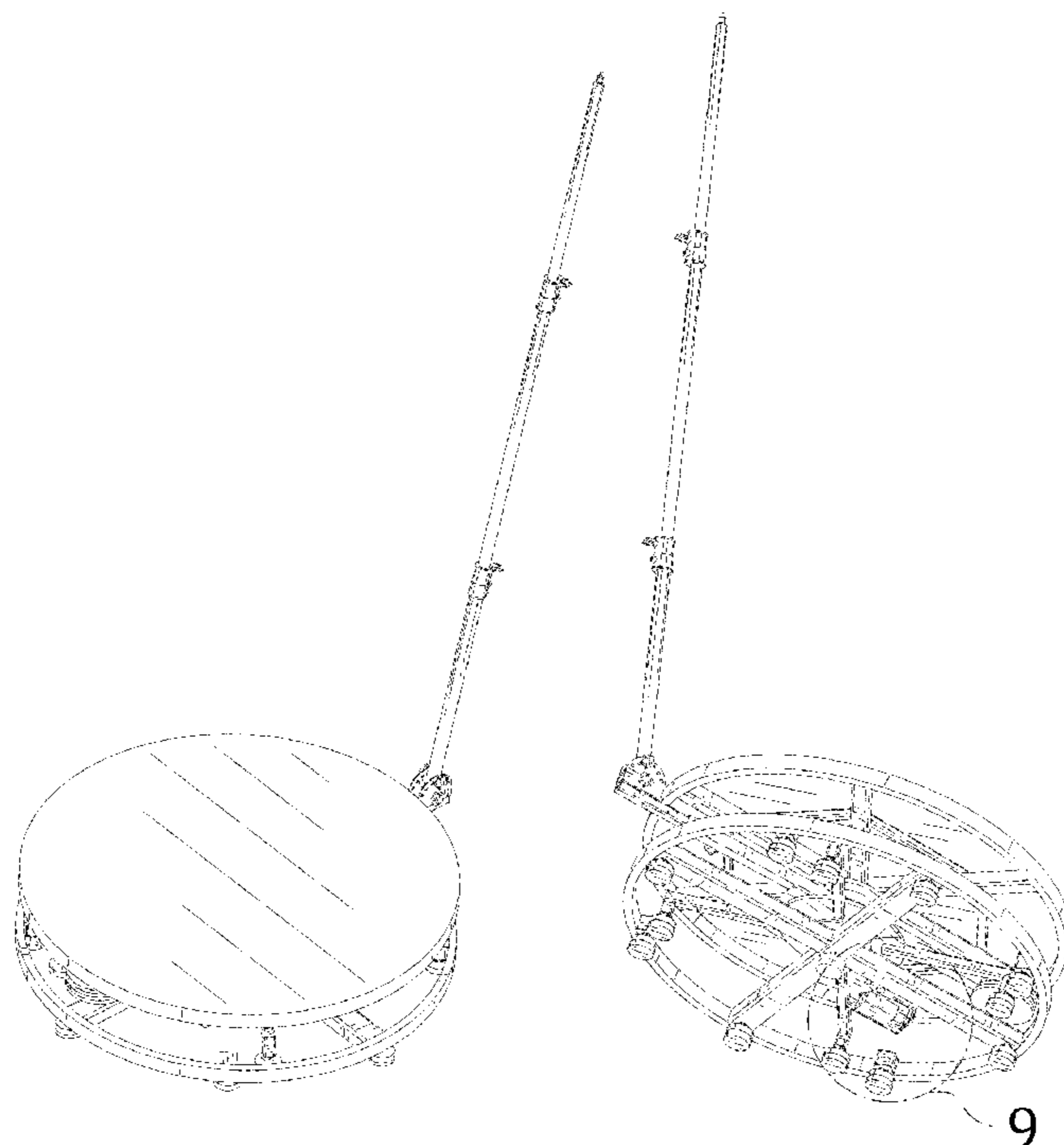

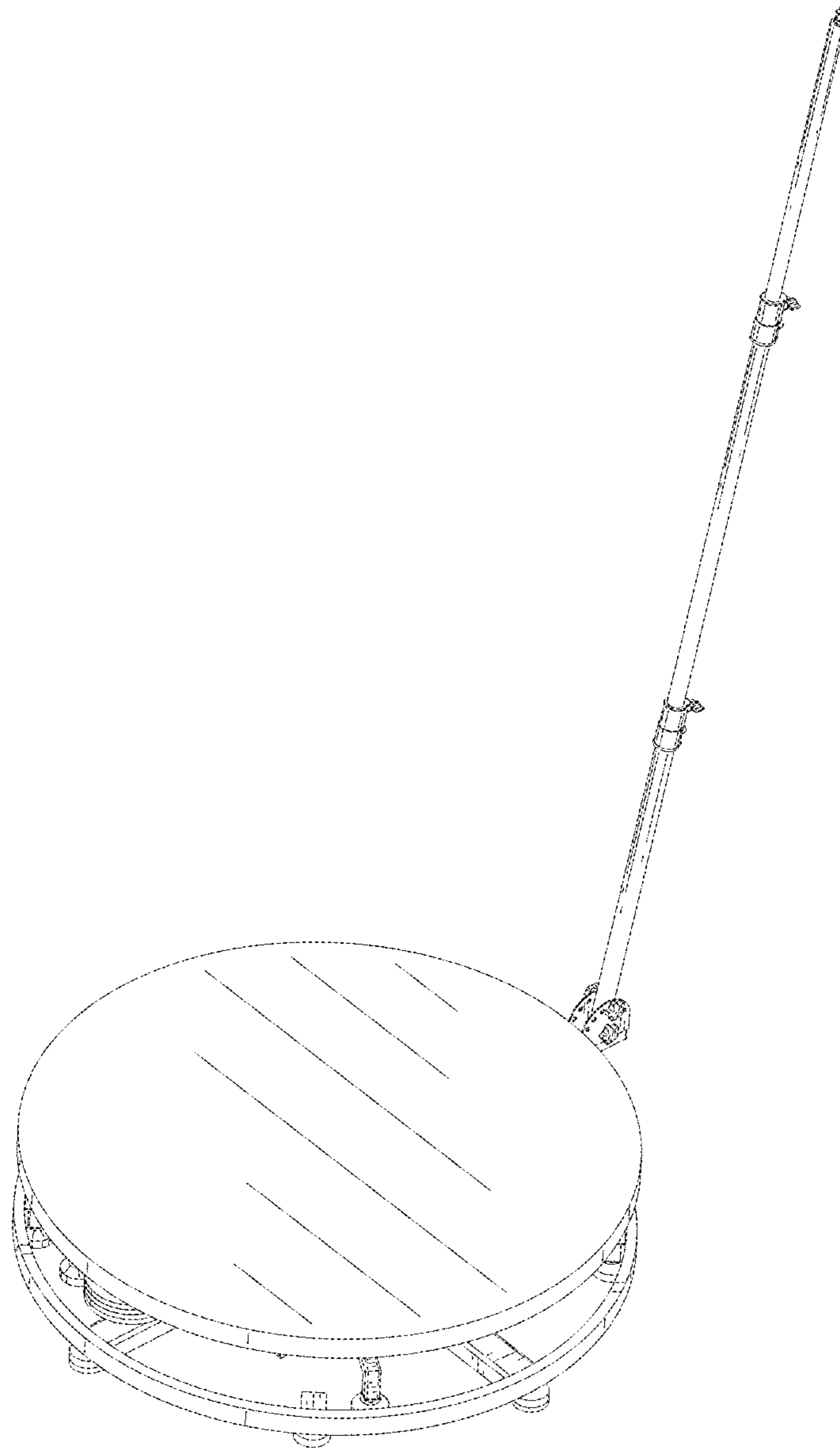

FIG. 1

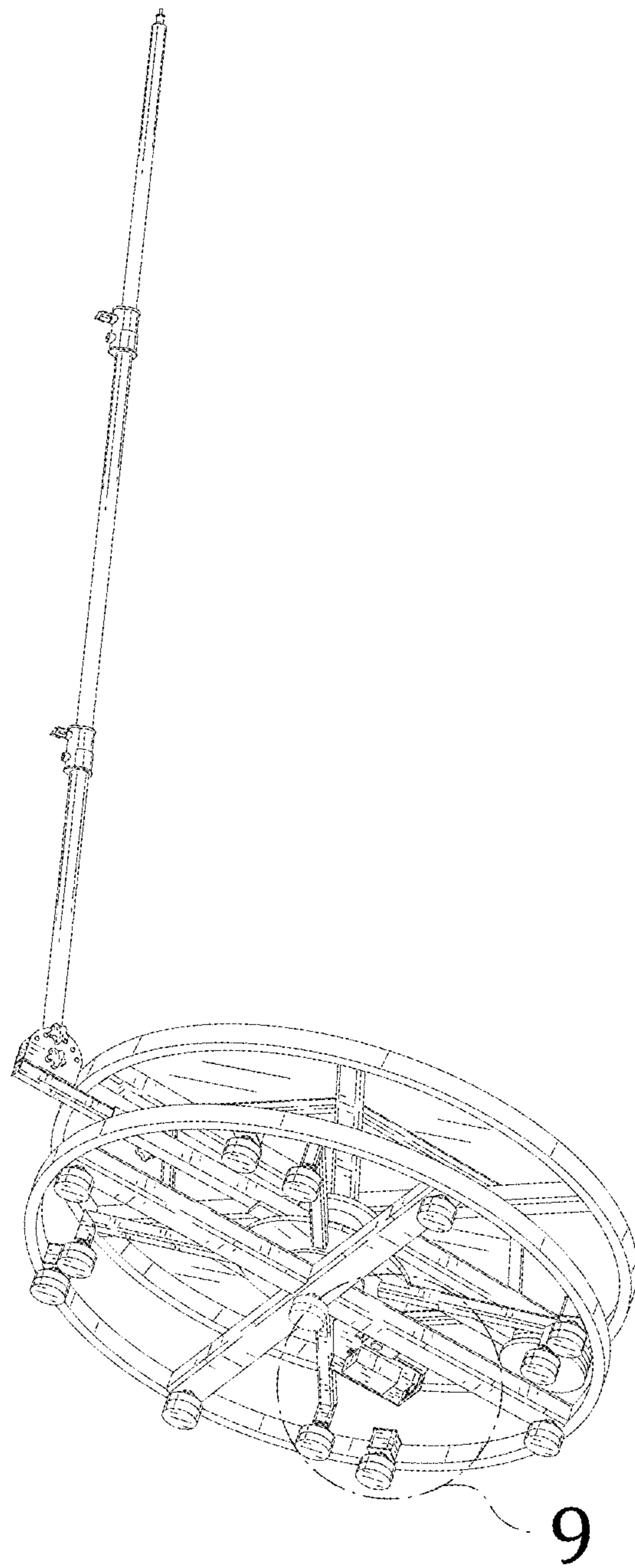

FIG. 2

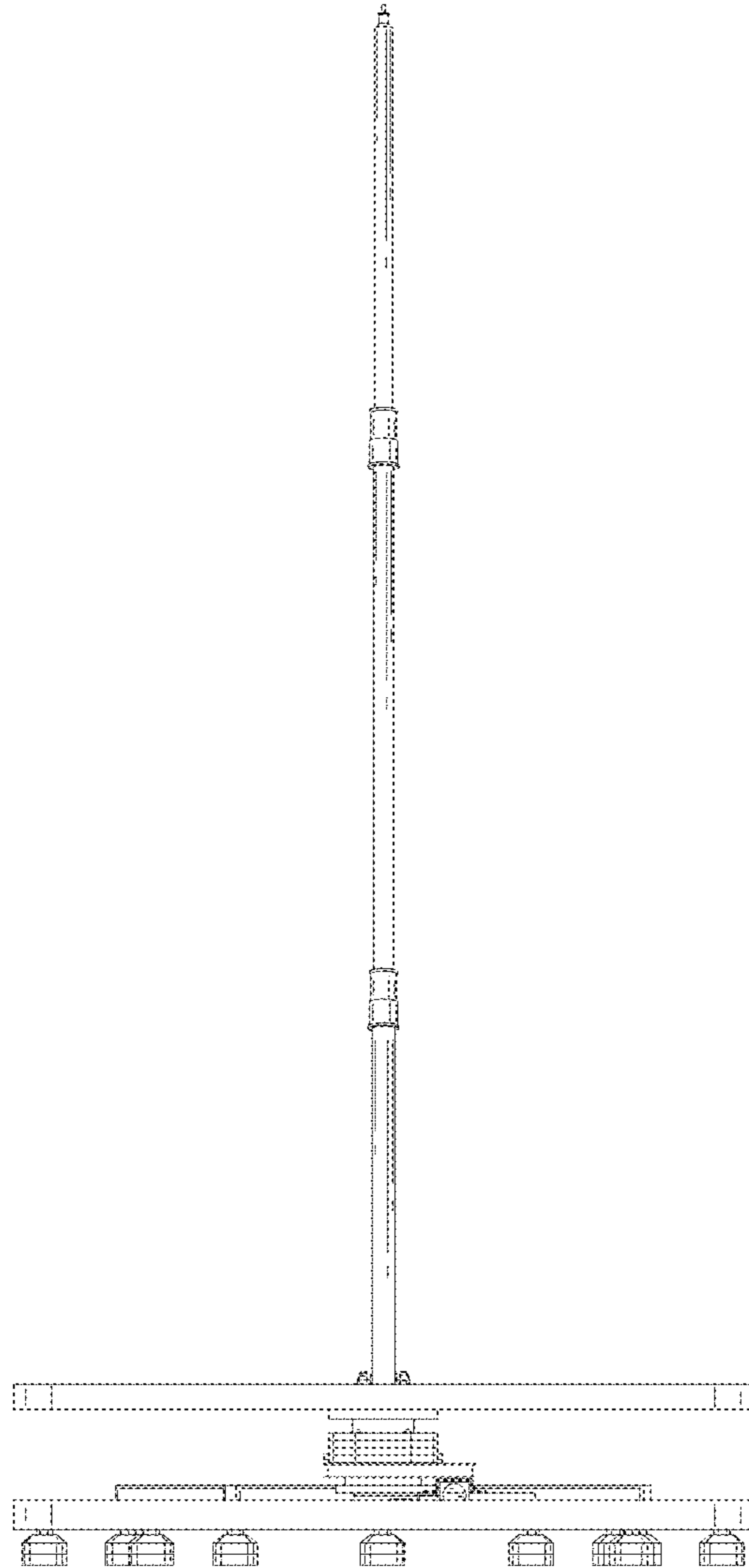

FIG. 3

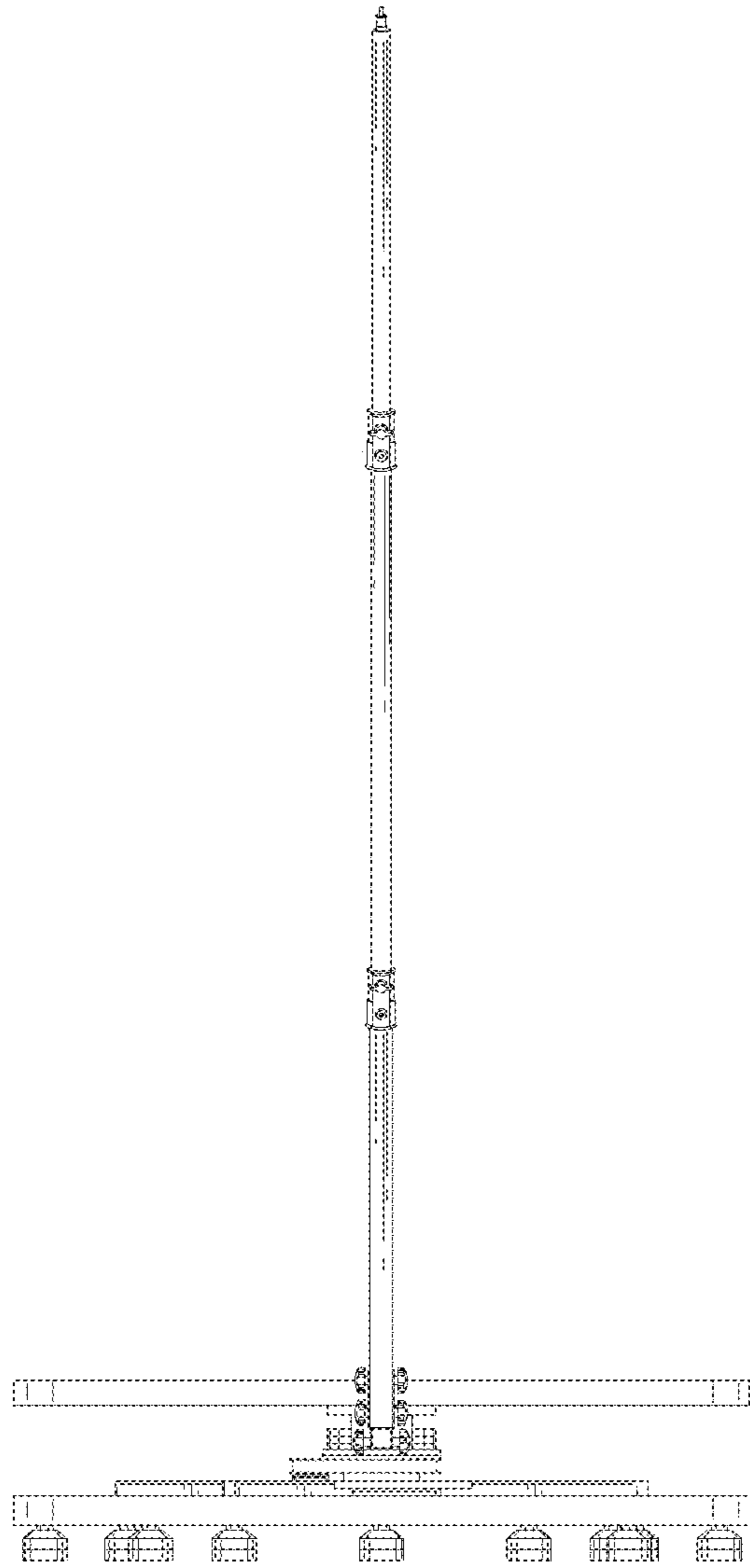

FIG. 4

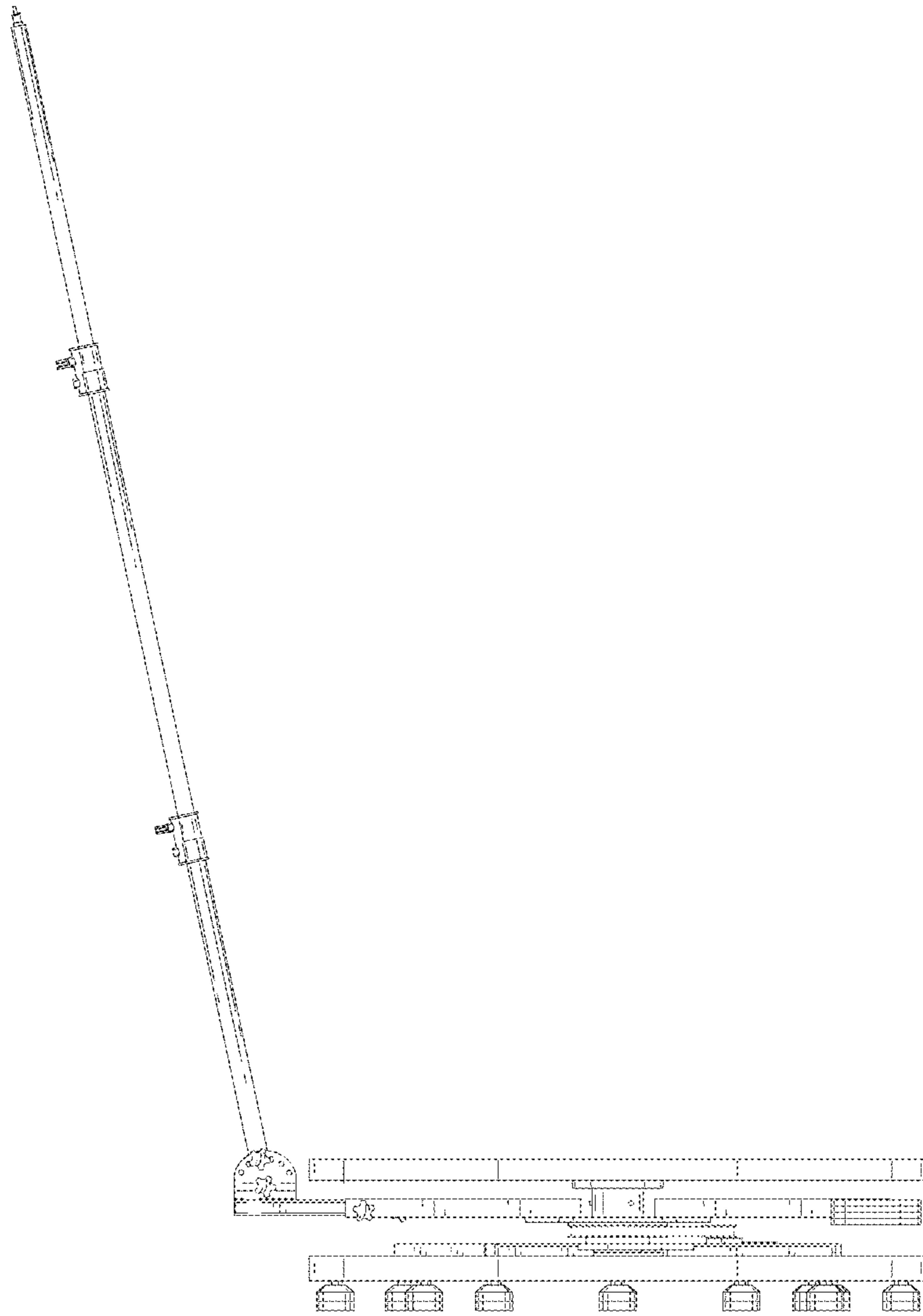

FIG. 5

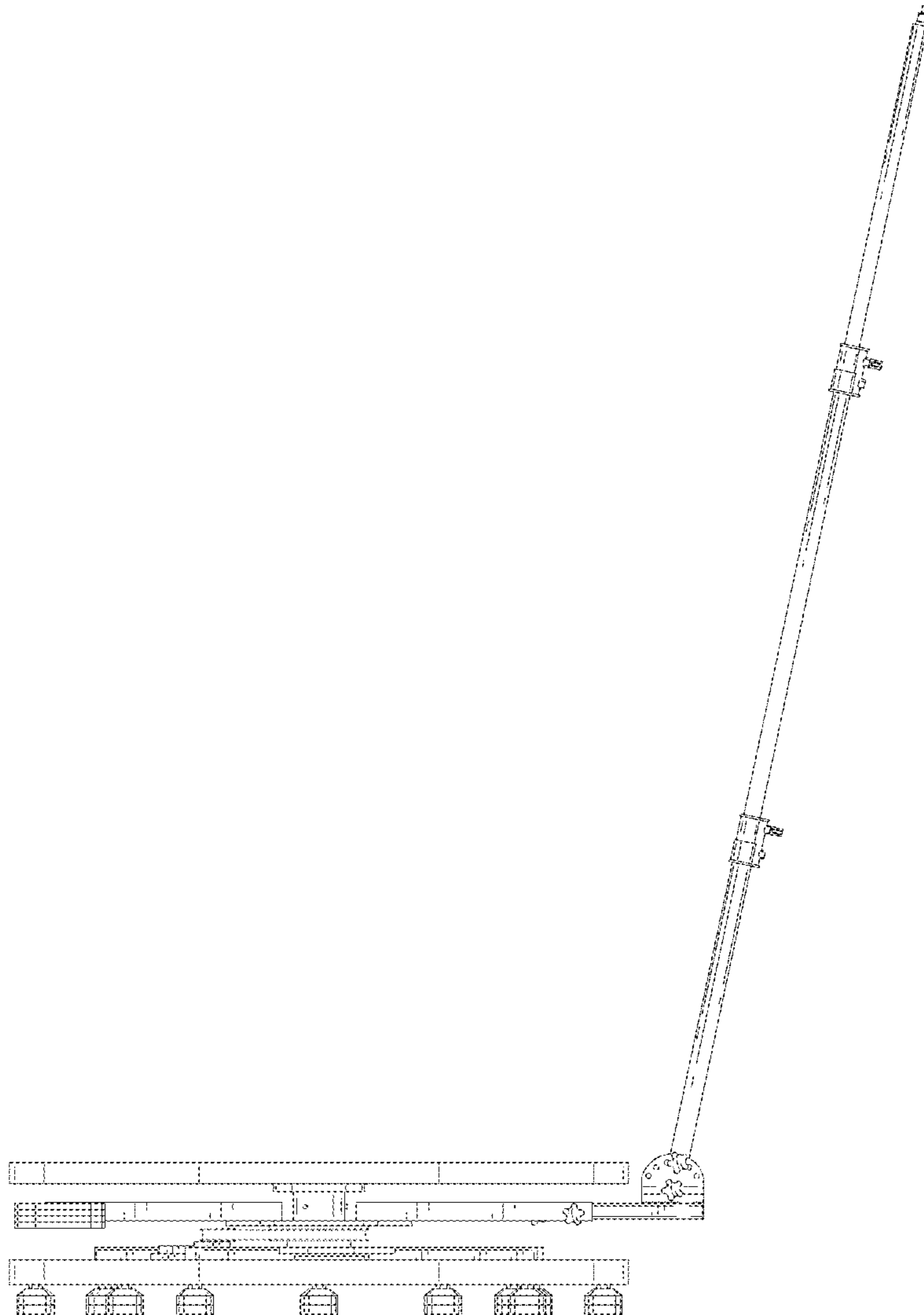

FIG. 6

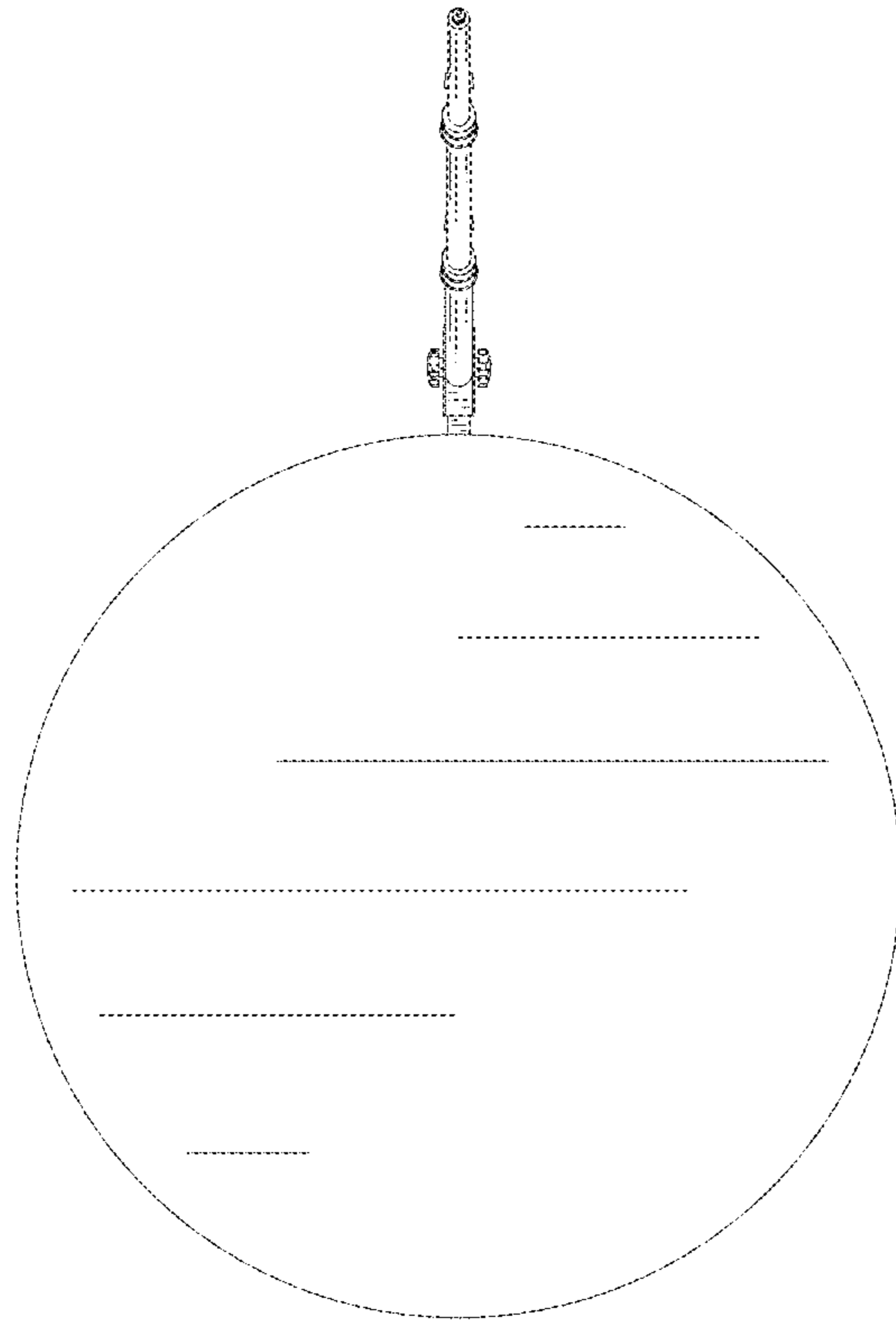

FIG. 7

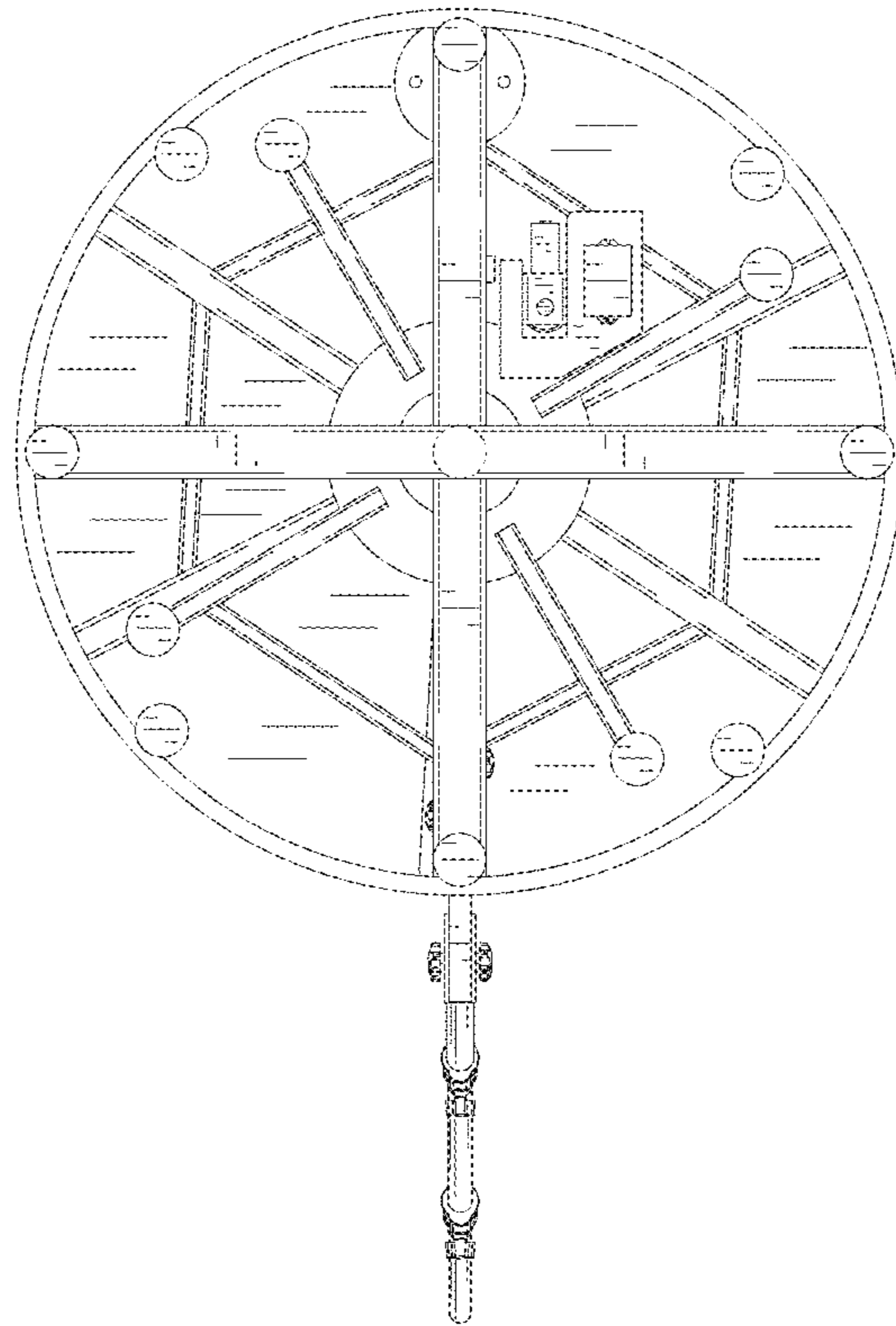

FIG. 8

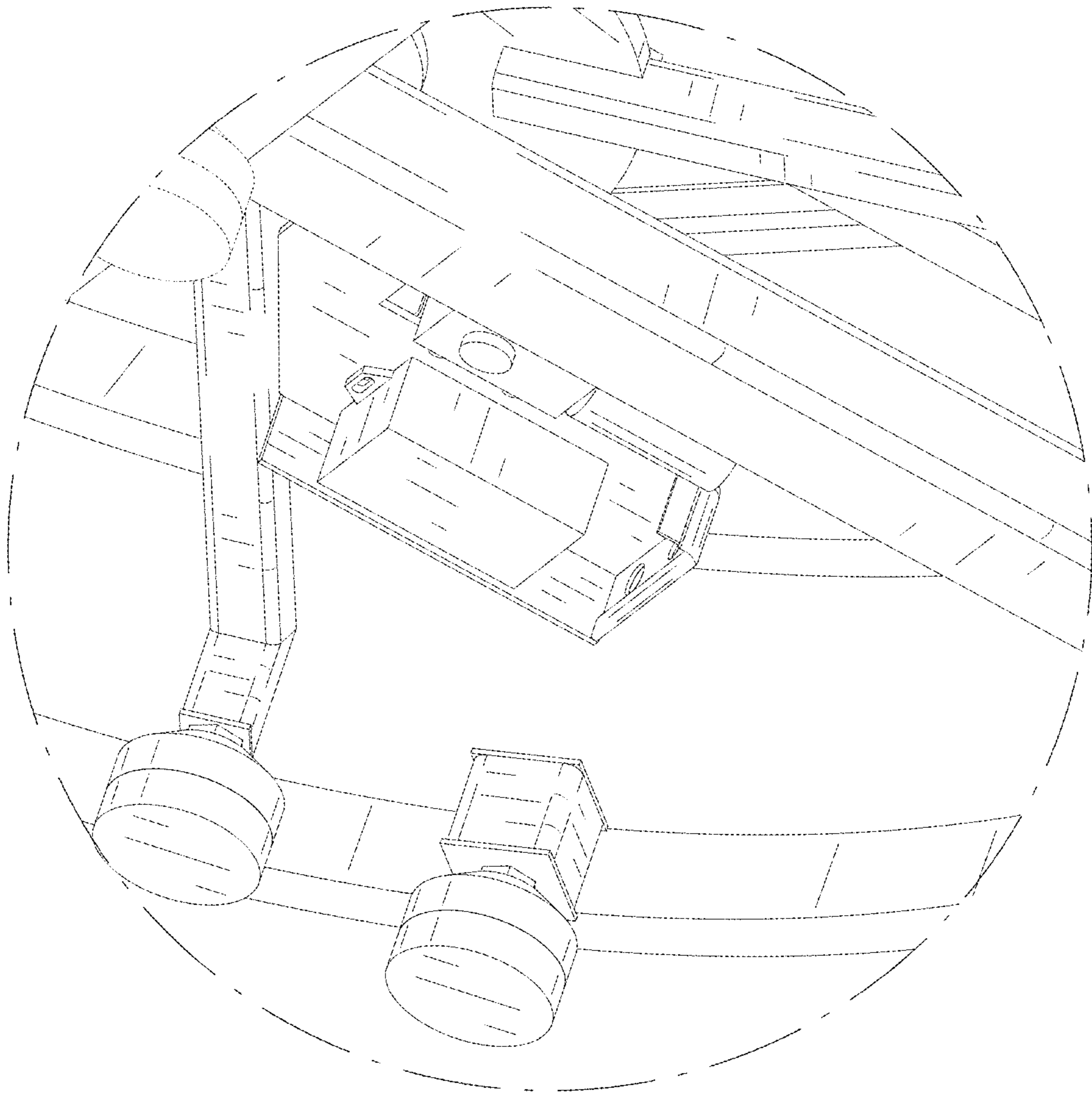

FIG. 9