



US00D957988S

(12) **United States Design Patent**
Steininger

(10) **Patent No.:** **US D957,988 S**
(45) **Date of Patent:** **** *Jul. 19, 2022**

(54) **PROTECTION BOARD MOUNTING BRACKET**

(71) Applicant: **Richard Steininger**, North Jackson, OH (US)

(72) Inventor: **Richard Steininger**, North Jackson, OH (US)

(*) Notice: This patent is subject to a terminal disclaimer.

(**) Term: **15 Years**

(21) Appl. No.: **29/719,597**

(22) Filed: **Jan. 6, 2020**

Related U.S. Application Data

(63) Continuation-in-part of application No. 15/585,774, filed on May 3, 2017, now Pat. No. 10,596,921.

(51) **LOC (13) Cl.** **12-03**

(52) **U.S. Cl.**
USPC **D12/51**

(58) **Field of Classification Search**
USPC D12/48, 49, 50, 51; D8/349, 354, 363, D8/364, 380
CPC B60M 1/307; B60M 1/04
See application file for complete search history.

(56) **References Cited**

U.S. PATENT DOCUMENTS

- 726,599 A * 4/1903 Wheeler et al. B60M 1/307 191/32
- 1,532,836 A 4/1925 Schmid et al.
- 1,837,096 A * 12/1931 Banks B60M 1/04 248/297.31
- 2,048,367 A 7/1936 Banks
- 2,502,756 A 4/1950 Schmid
- D211,606 S * 7/1968 Harmsen D12/51
- D215,141 S * 9/1969 Harmsen D8/380
- 3,475,568 A 10/1969 Dehn

- 3,575,576 A * 4/1971 Harmsen B60M 1/04 191/32
- 3,614,340 A * 10/1971 Harmsen B60M 1/307 191/32
- 3,806,672 A 4/1974 Landis
- 4,318,462 A 3/1982 Weinhaus
- D352,015 S 11/1994 Esworthy
- 5,905,216 A 5/1999 Davis
- 6,386,492 B1 5/2002 Brown et al.

(Continued)

FOREIGN PATENT DOCUMENTS

- DE 922052 C * 1/1955 B60M 1/307
- DE 10122793 C1 * 11/2002 B60M 1/307

(Continued)

OTHER PUBLICATIONS

www.conductix.com, "Transit Power Rail For Third Rail and APM Systems", Conductix-Wampfler, 2017, 16 pages.
http://www.lbfoster.com, "Transit Products", 2017, 7 pages.

Primary Examiner — Ania Aman
(74) *Attorney, Agent, or Firm* — Fay Sharpe LLP

(57) **CLAIM**

The ornamental design for a protection board mounting bracket, as shown and described.

DESCRIPTION

FIG. 1 is a rear perspective view of a protection board mounting bracket showing my new design; FIG. 2 is a right side elevational view thereof, with the left side elevational view being a mirror image thereof; FIG. 3 is a rear elevational view thereof; FIG. 4 is a front perspective view thereof partially broken away; and, FIG. 5 is a front perspective view thereof. In the drawings, the broken lines depict unclaimed subject matter only and form no part of the claimed design.

1 Claim, 5 Drawing Sheets

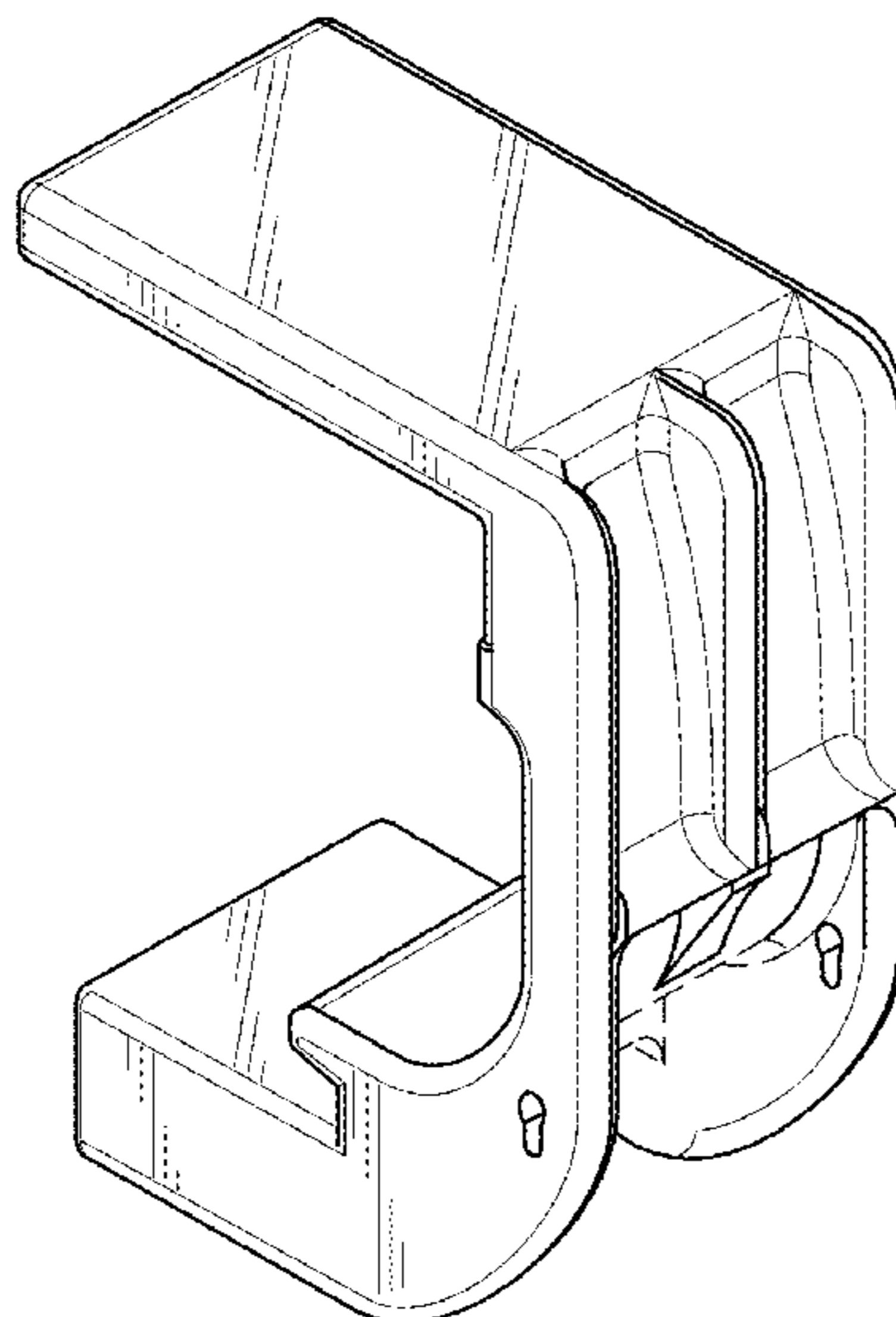

(56)

References Cited

U.S. PATENT DOCUMENTS

D616,791 S 6/2010 Ciloglu et al.
7,926,634 B1 4/2011 Morales
D702,596 S 4/2014 Ciloglu
D724,490 S 3/2015 Ciloglu et al.
D816,548 S 5/2018 Soyomez et al.
2017/0320404 A1 11/2017 Steininger

FOREIGN PATENT DOCUMENTS

DE 20 2012 101 576 U1 9/2013
DE 202012102995 U1 * 11/2013 B60M 1/307
DE 202017101189 U1 * 6/2018 B60M 1/307
EP 2657066 A2 * 10/2013 B60M 1/307

* cited by examiner

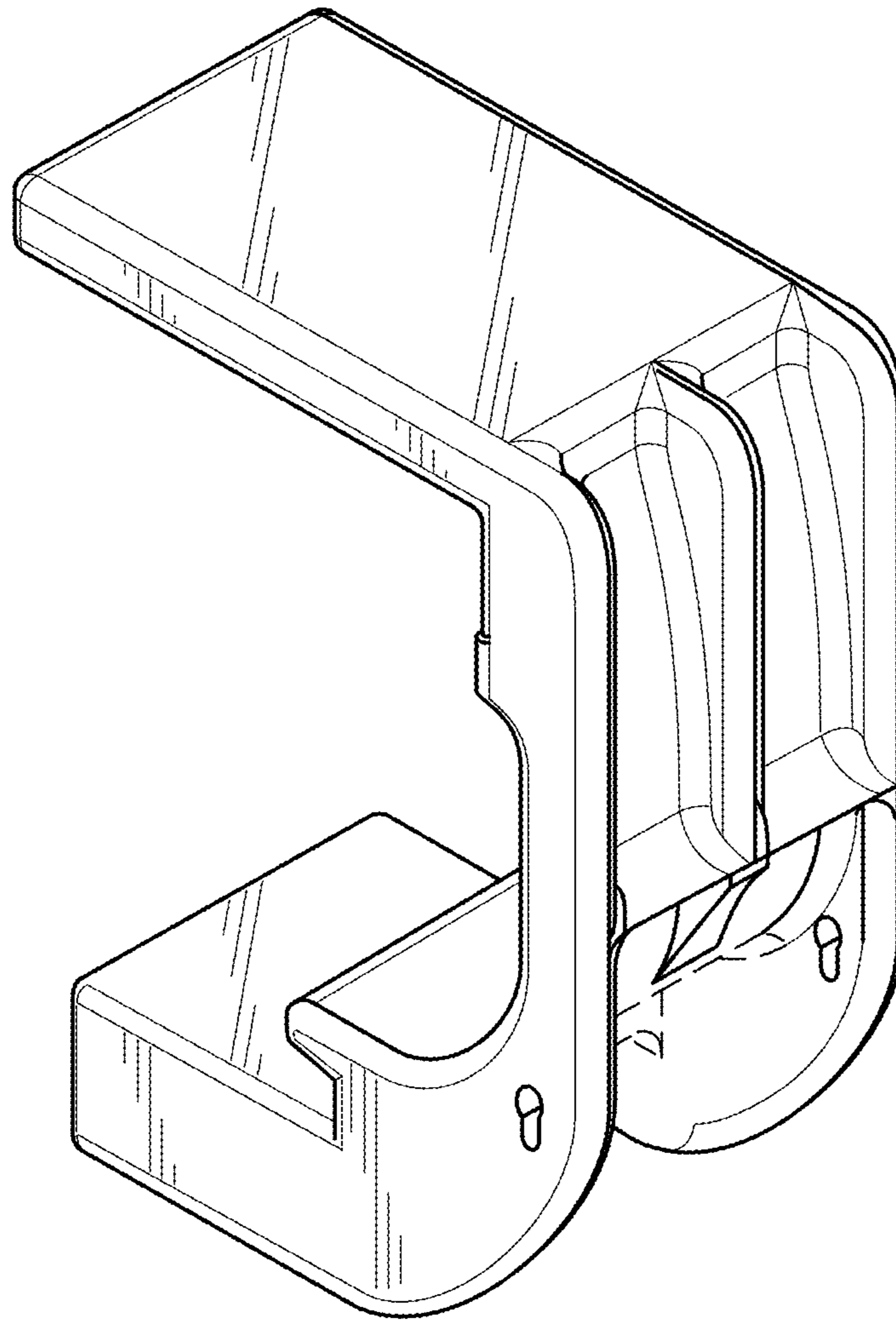

FIG. 1

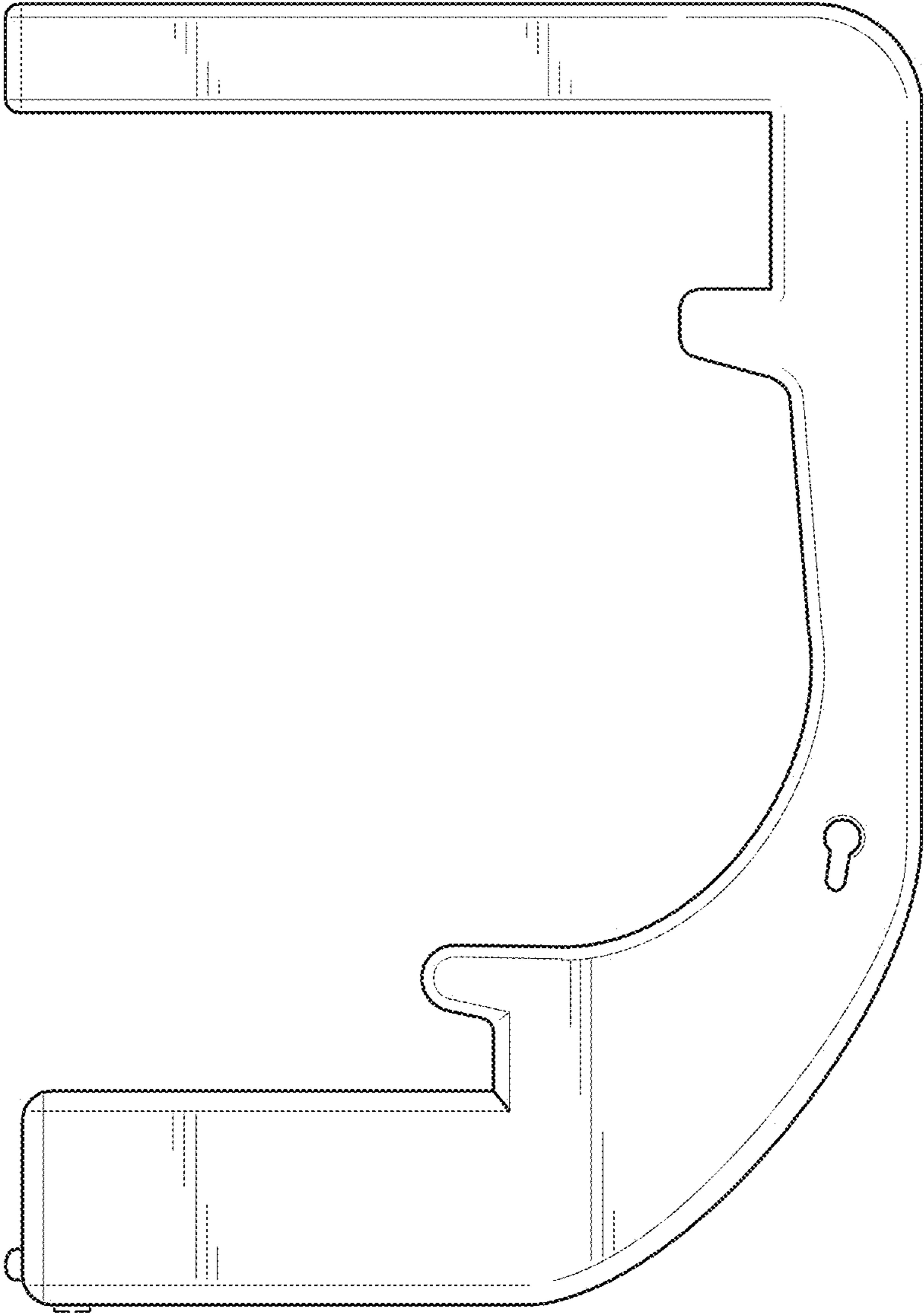

FIG. 2

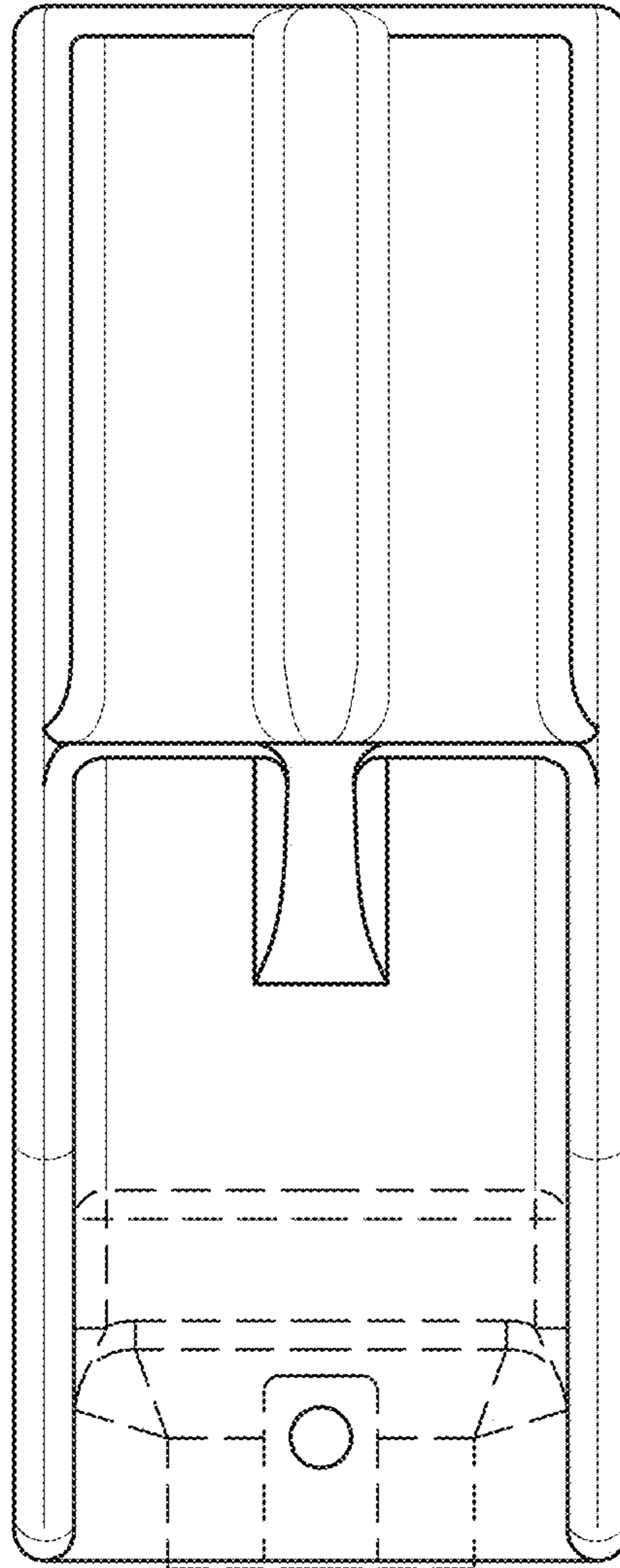

FIG. 3

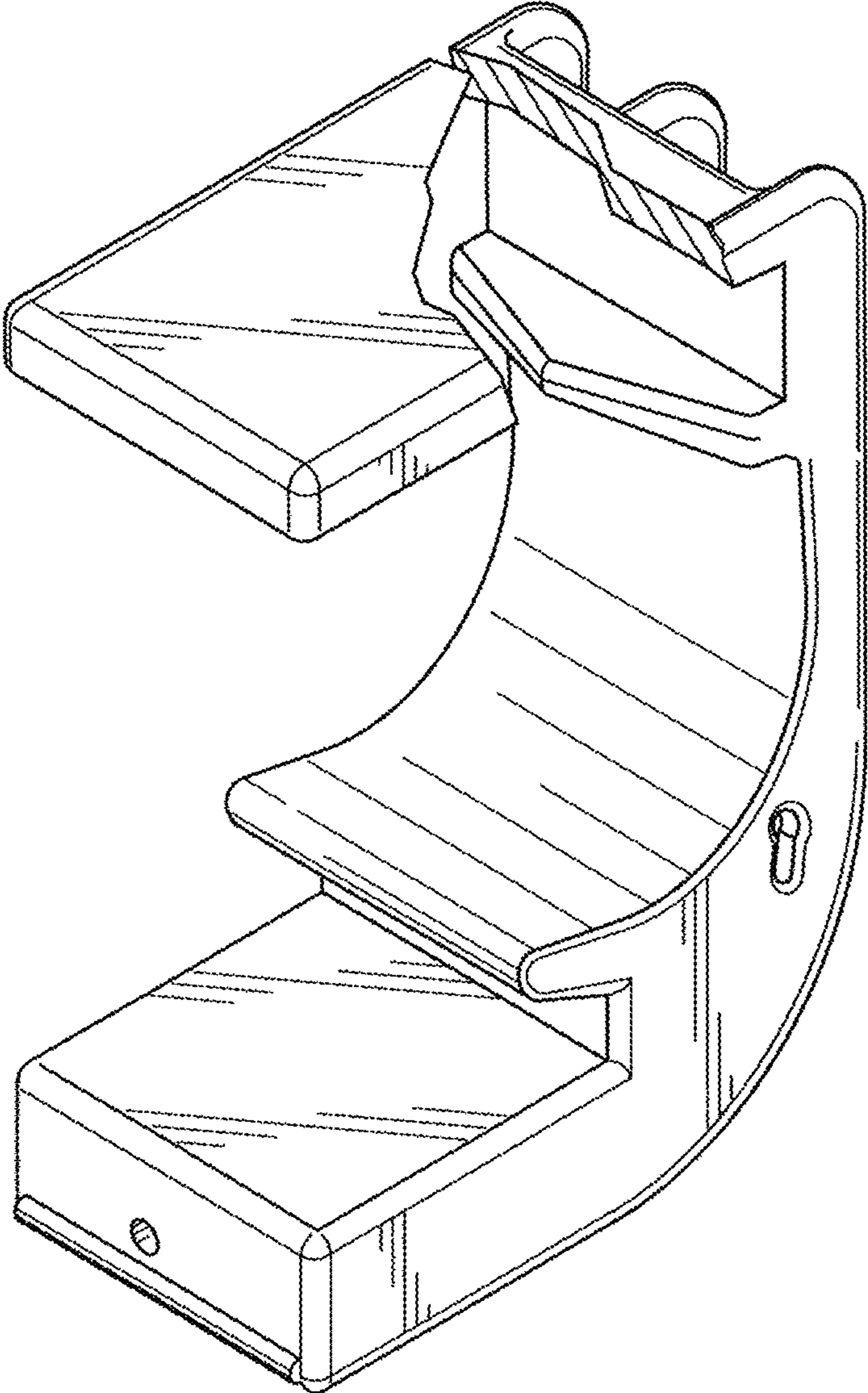

FIG. 4

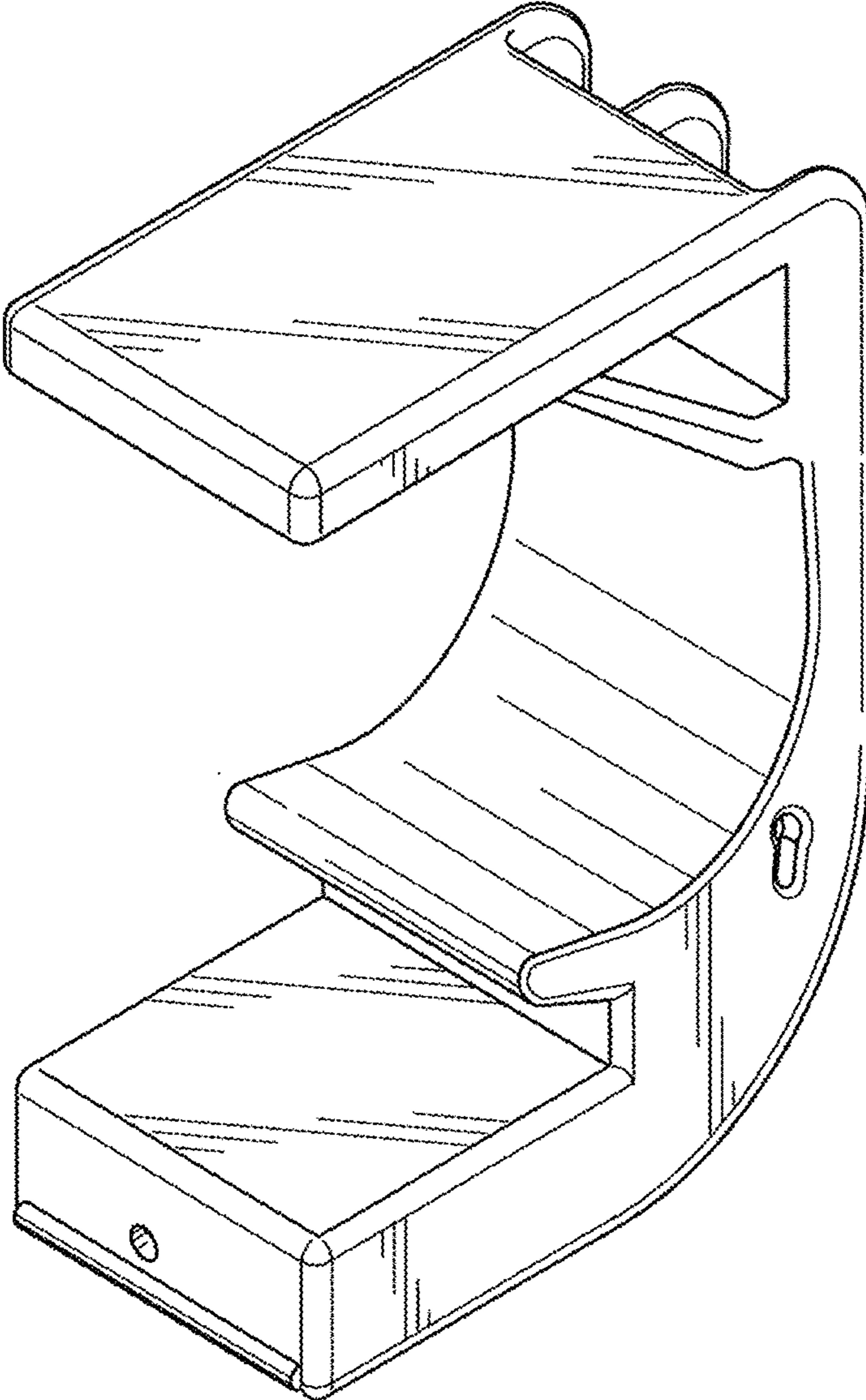

FIG. 5