



US00D957466S

(12) **United States Design Patent** (10) **Patent No.:** **US D957,466 S**
Wei (45) **Date of Patent:** **** Jul. 12, 2022**

(54) **INTAKE MANIFOLD**

(71) Applicant: **DeepMotor Inc**, Rancho Cucamonga, CA (US)

(72) Inventor: **Yong Wei**, Rancho Cucamonga, CA (US)

(73) Assignee: **DEEPMOTOR INC**, Rancho Cucamonga, CA (US)

(**) Term: **15 Years**

(21) Appl. No.: **29/757,783**

(22) Filed: **Nov. 10, 2020**

(51) **LOC (13) Cl.** **15-01**

(52) **U.S. Cl.**
USPC **D15/5**

(58) **Field of Classification Search**
USPC D15/1, 2, 3, 4, 5, 6
CPC F02M 35/104; F02M 35/108; F02M 35/1085; F02M 35/116

See application file for complete search history.

(56) **References Cited**

U.S. PATENT DOCUMENTS

4,210,107	A *	7/1980	Shaffer	F02B 27/0294	123/184.56
4,925,510	A	5/1990	Hojo et al.			
D364,628	S	11/1995	Haller			
5,494,011	A	2/1996	Haller			
5,551,386	A *	9/1996	Gambardella	F02M 35/116	123/184.35
5,911,205	A *	6/1999	Gambardella	F02M 35/116	123/184.53
6,053,148	A *	4/2000	Glovatsky	F02M 51/005	123/470

(Continued)

FOREIGN PATENT DOCUMENTS

CN	303479863	12/2015
CN	303727690	6/2016

(Continued)

OTHER PUBLICATIONS

Alibaba.com: "BK-3123SET Supra 2JZ-GE Billet Intake manifold with fuel rail and throttle body 90mm", 4 pages, retrieved from the Internet <URL: http://www.bkcmotorsport.com/product/60462533019-802641114/bk_3123SET_supra_2JZ_GE_Billet_Intake_manifold_with_fuel_and_rail_and_throttle_body_90mm.html>, [retrieved on Jun. 2, 2020].

(Continued)

Primary Examiner — Ania Aman

(74) *Attorney, Agent, or Firm* — Loza & Loza, LLP; Heidi Eisenhut

(57) **CLAIM**

The ornamental design for an intake manifold, as shown and described.

DESCRIPTION

FIG. 1 is a front, right, top perspective view of an intake manifold;
FIG. 2 is a front, left, bottom perspective view of an intake manifold
FIG. 3 is a left side elevation view of the intake manifold of FIG. 1;
FIG. 4 is a right side elevation view of the intake manifold of FIG. 1;
FIG. 5 is a rear elevation view of the intake manifold of FIG. 1;
FIG. 6 is a front elevation view of the intake manifold of FIG. 1;
FIG. 7 is a top plan view of the intake manifold of FIG. 1; and,
FIG. 8 is a bottom plan view of the intake manifold of FIG. 1.
The broken lines show features of the intake manifold that form no part of the claimed design.

1 Claim, 7 Drawing Sheets

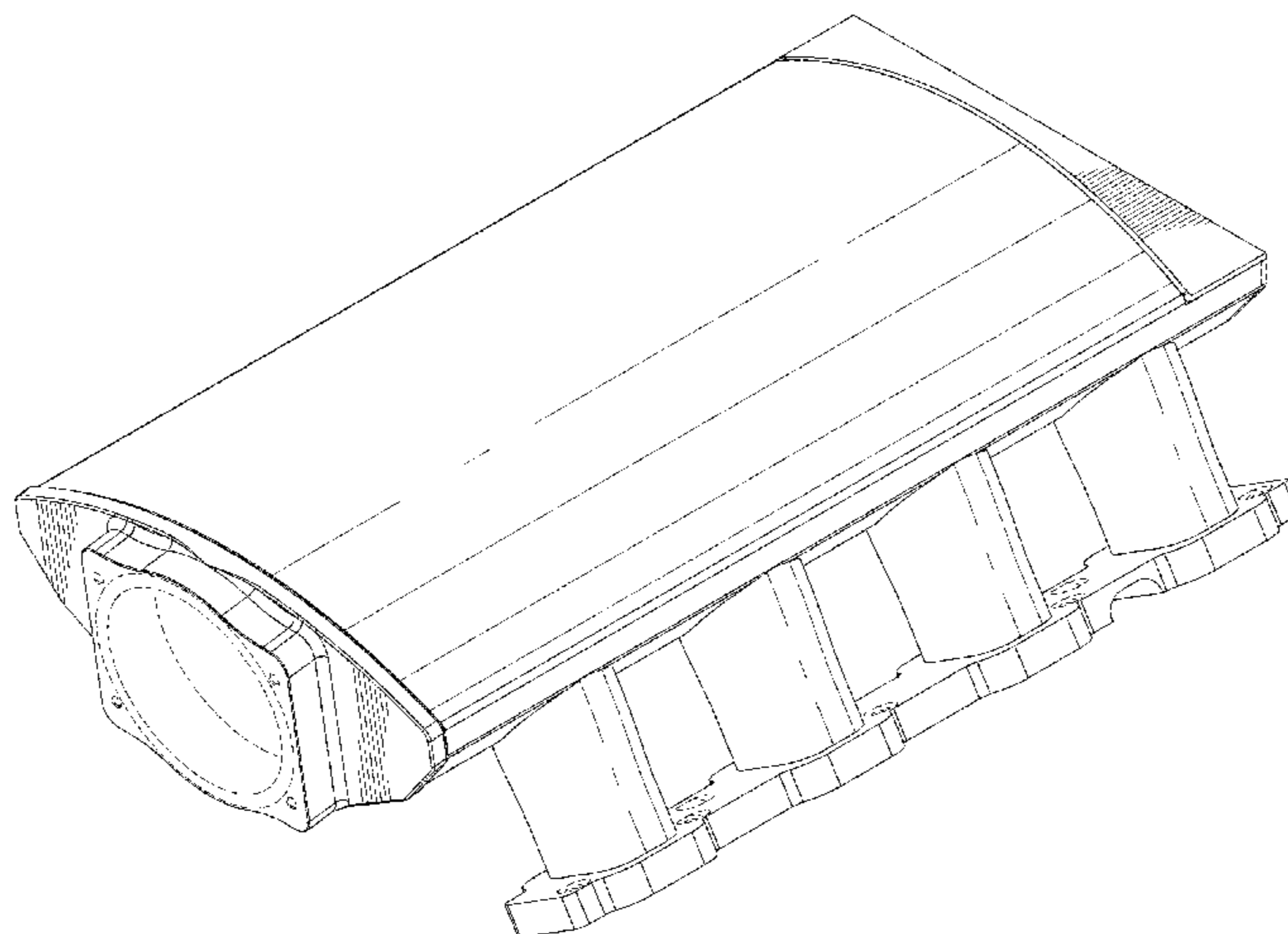

(56)

References Cited

U.S. PATENT DOCUMENTS

D517,567	S	3/2006	Teeter	
7,086,365	B1	8/2006	Teeter	
D654,094	S	2/2012	Dralle	
8,122,864	B2	2/2012	Randall et al.	
8,220,430	B2	7/2012	Gupta	
D673,977	S	1/2013	Hsu et al.	
D673,979	S	1/2013	Finnican	
D674,408	S	1/2013	Hsu et al.	
D676,460	S	2/2013	Grubisich	
D677,699	S	3/2013	Finnican	
D680,132	S	4/2013	Finnican	
D688,614	S	8/2013	Meulen	
D700,557	S	3/2014	Glaeser	
D737,862	S	9/2015	Finnican	
9,273,653	B2	3/2016	Wilson	
9,617,957	B2	4/2017	Shinkai et al.	
D802,628	S	11/2017	Fischetto	
D812,100	S	3/2018	Litchfield	
D814,523	S	4/2018	Vaninetti et al.	
D894,239	S *	8/2020	Coates	D15/5
D908,141	S *	1/2021	Wei	D15/5
2010/0269777	A1	10/2010	Jasper	
2011/0169186	A1	7/2011	Bruman et al.	
2017/0067424	A1	3/2017	Krogdhal	
2017/0175688	A1	6/2017	Nola et al.	
2017/0204817	A1	7/2017	Nola	
2017/0211527	A1	7/2017	Nola	
2019/0128221	A1	5/2019	Tiramani et al.	

FOREIGN PATENT DOCUMENTS

EP	1046808	A2 *	10/2000	F02M 35/10039
EP	1772615	A2	4/2007		
JP	2000130275	A *	5/2000	F02B 75/22

OTHER PUBLICATIONS

Amazon.com: "JEGS Performance Products 513056 Fabricated Intake Manifold 2011-2014 Ford 5.0L: Automotive", 5 pages, retrieved from the Internet <URL: https://www.amazon.com/...rd_wg=aiTq0&pf_rd_p=7cd8f929-4335-4bf2-a554-7d7588b3dd5f&pf_rd_r=XKMJXZPC1G97VMEXBFW&psc=1&refRID=XKMJXZPC1G97VMEXBFW> [retrieved on Feb. 27, 2020].
 AMAZON.COM: "2JZ GTE Tig Welded Sheet Metal intake W/Rails and 90mm Thottle body", 6 pages, retrieved from the Internet <URL: <https://www.amazon.com/Welded-Sheet-Metal-intake-Thottle/>

dp/B0748Y6QJP/ref=sr_1_1?dchild=1&keywords=B0748Y6QJP&qid=15913203938s=automotive&sr=1-1>, [retrieved 2017].
 AMAZON.COM: "Billet Custom Intake Manifold Kit for 1993+ and up Supra MK4 2JZ-GTE w/ 90MM Throttle Body & Hi Flow Fuel Rail", 5 pages, retrieved from the Internet <URL: https://www.amazon.com/TOYOTA-2JZ-GTE-CUSTOM-MANI-FOLD-THROTTLE/dp/B071F9CT8Q/ref=sr_1_16?dchild=1&keywords=manifold&qid=1591156534&sr=8-16&srs=20639935011>, [retrieved on Jun. 2, 2020].
 AMAZON.COM: search results for "intake manifold deepmotor search", 7 pages, retrieved from the internet <URL: https://www.amazon.com/s?k=intake+manifold+deepmotor&ref=nb_sb_noss_2> [retrieved on Jun. 2, 2020].
 AMAZON.COM: "A-Team Performance Intake Manifold 102mm Throttle Body Sheet Metal Fabricated EFI 15° Throttle Opening Compatible with Chevrolet Chevy GMC Pontiac LS LS1 LS2 LS6 Black", 7 pages, retrieved from the Internet <URL: https://www.amazon.com/Team-Performance-Fabricated-Compatible-Chevrolet/dp/B076Z97CCW/ref=cm_cr_arp_d_product_top?ie=UTF8> [retrieved on Feb. 22, 2021].
 AMAZON.COM: "Sniper 822112-1 Black Low-Profile Sheet Metal Fabricated Intake Manifold for LS3/L92 w/ 102mm Throttle Body Opening & Fuel Rail Kit", 5 pages, retrieved from the Internet <URL: https://www.amazon.com/Sniper-822112-1-Low-Profile-Fabricated-Manifold/dp/B07RLMX385/ref=sr_1_4?keywords=LS3+L92+intake+manifold+with+fuel+rail+kit+102mm&qid=1582846561&s=automotive&sr=1-4> [retrieved on Feb. 27, 2020].
 AMAZON.COM: "BMW N54 3.0L TIG Weld Intake Manifold 135i 335i 535i E90 to E93 E60 E61 E82 E88", 5 pages, retrieved from the Internet <URL: https://www.amazon.com/3-0L-Weld-Intake-Manifold-135i/dp/B07B7D1VT2/ref=sr_1_fkmr1_2?keywords=BMW+N54+Billet+Intake+U+Manifold&qid=1582652714&s=automotive&sr=1-2-fkmr1> [retrieved on Feb. 25, 2020].
 EBAY.COM: "Items for sale by deepmo_64 | ebay", 3 pages, retrieved from the internet <URL: https://www.ebay.com/sch/deepmo_64/m.html?nkw=&armrs=1&_from=&jpg=200&rt=> [retrieved on Jun. 2, 2020].
 AMAZON.COM: "Tig Welding Aluminum Intake Manifold for BMW N54 3.0L: Automotive", 5 pages, retrieved from the internet <URL: https://www.amazon.com/Welded-Aluminum-Intake-Manifold-3-0L/dp/B07KTJNKL8/ref=pd_sbs_263_1/147-9724501-2684428?_encoding=UTF8&pdJj=BO7KTJNKL8&pd_rd_r=35f0a955-e3c3-4984-b6c2-ade6c7d97cOc&pd_rd_w=bmcnb&pd_rd_wg=4Z199&pUd_p=7cd8f929-4345-4bf2-a5544-7d7588b3dd5f&pUd_r=5HNTFPF2563487W1BVR4&psc=1&refRID=5HNTFPF25> [retrieved Feb. 25, 2020].

* cited by examiner

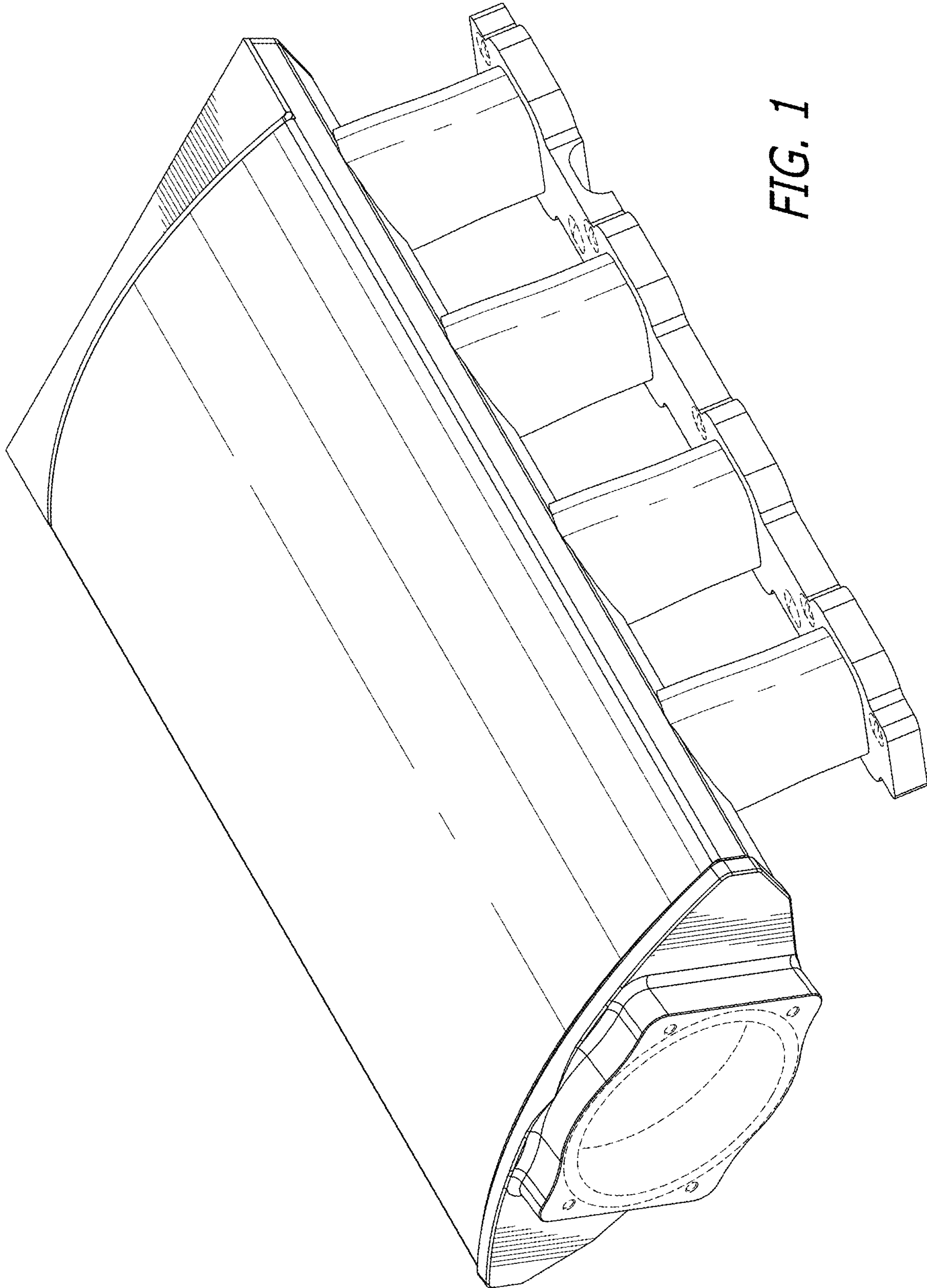

FIG. 1

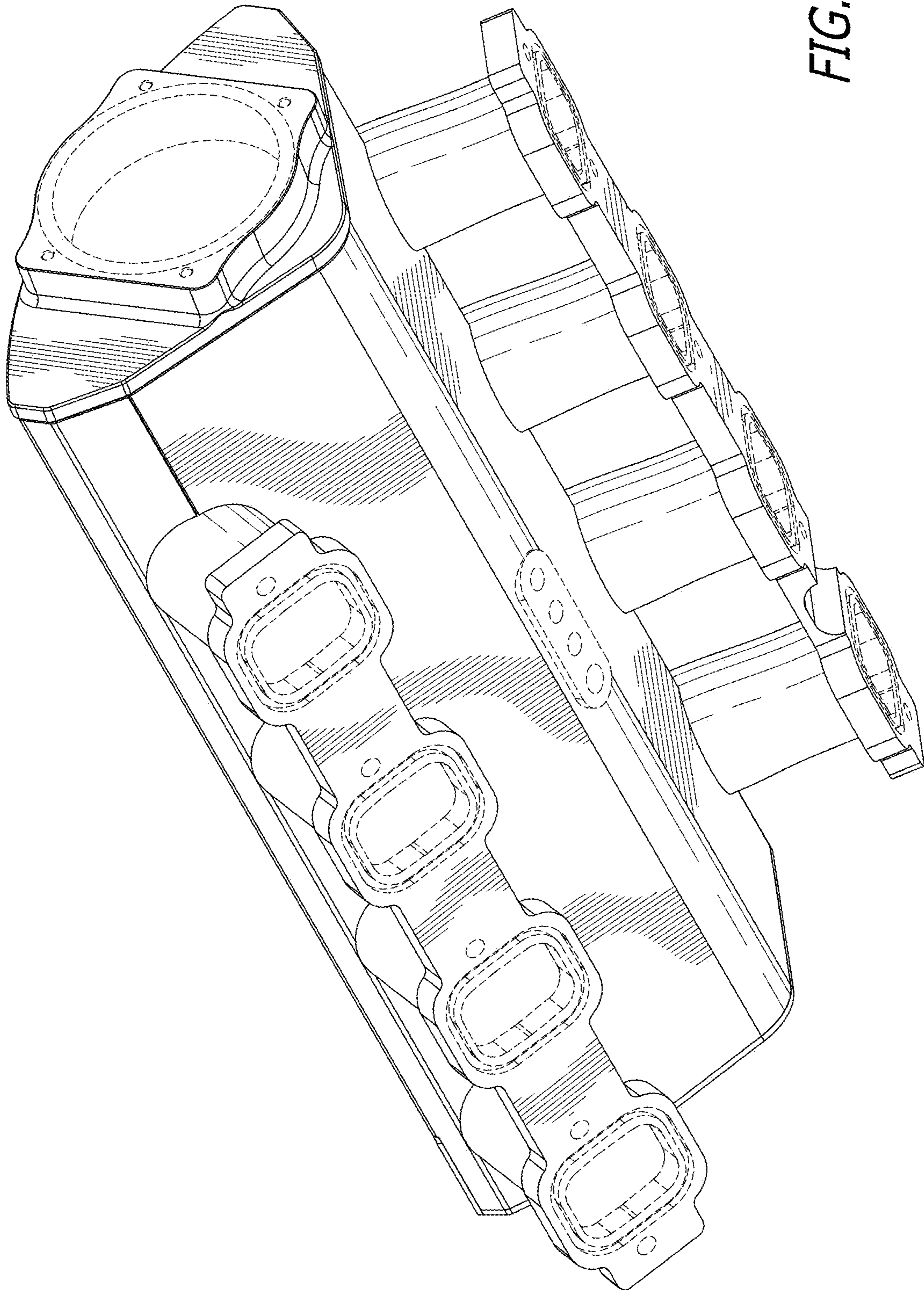

FIG. 2

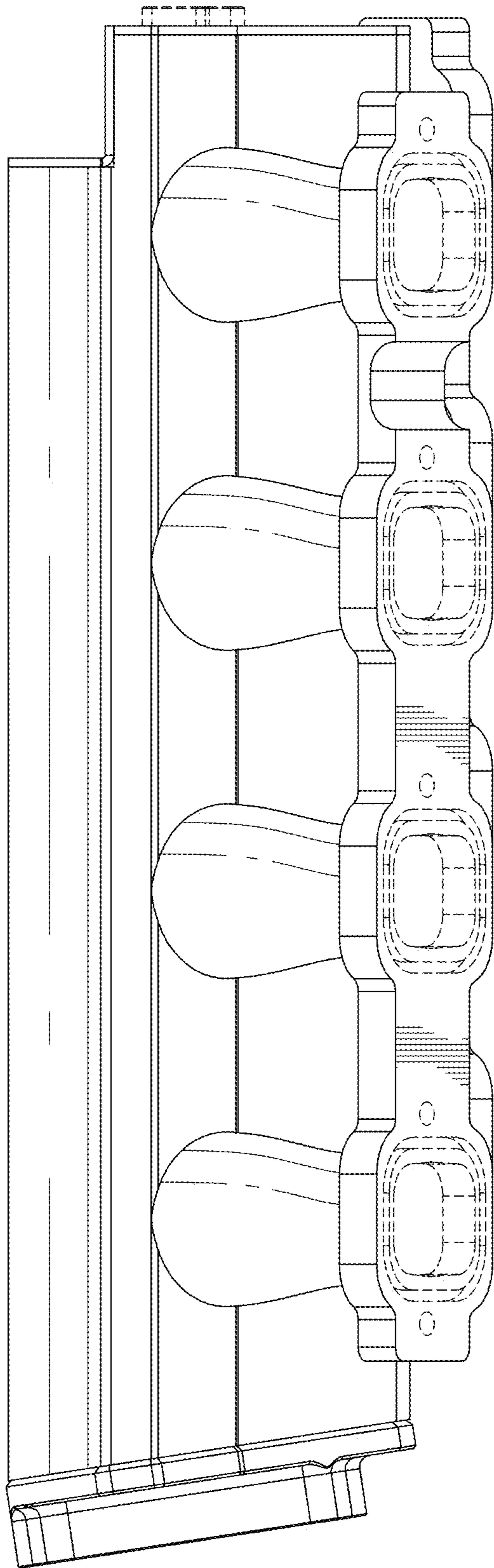

FIG. 3

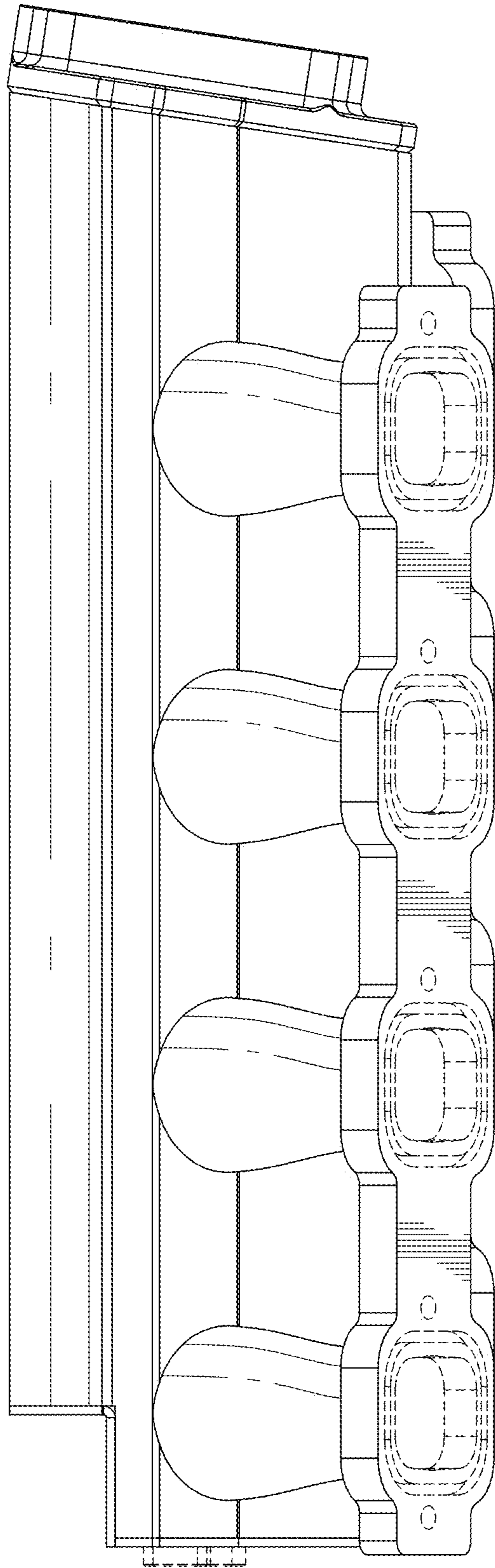

FIG. 4

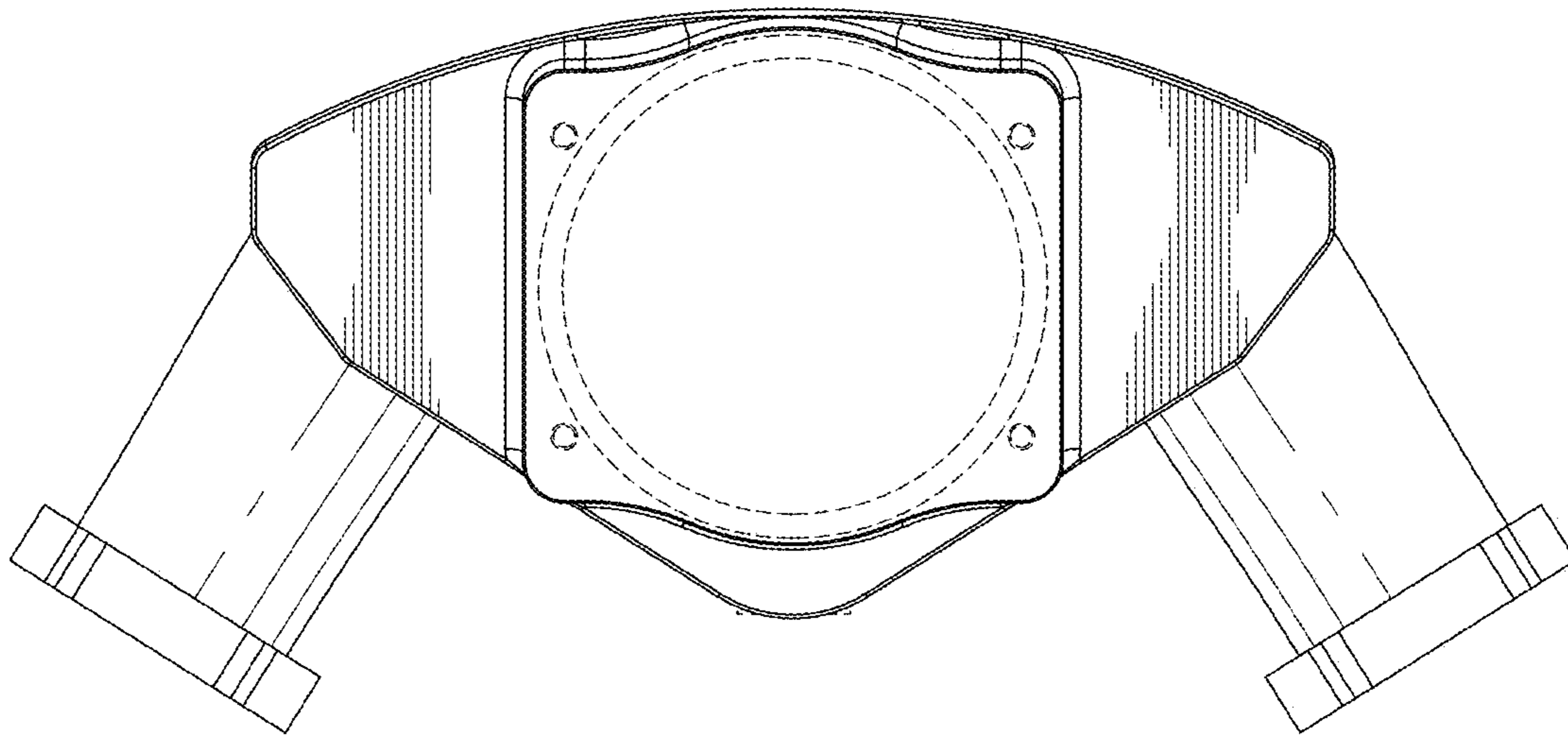

FIG. 5

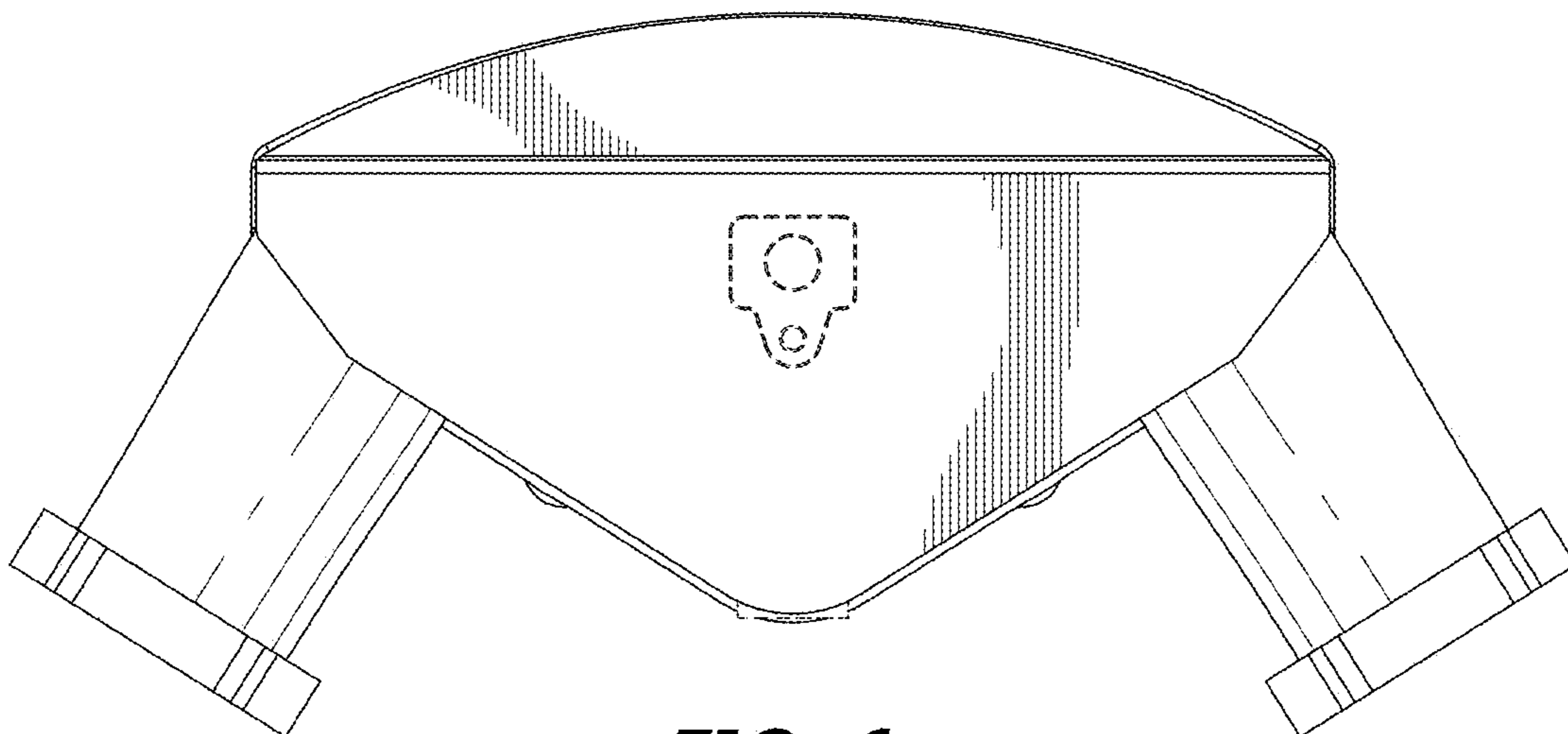

FIG. 6

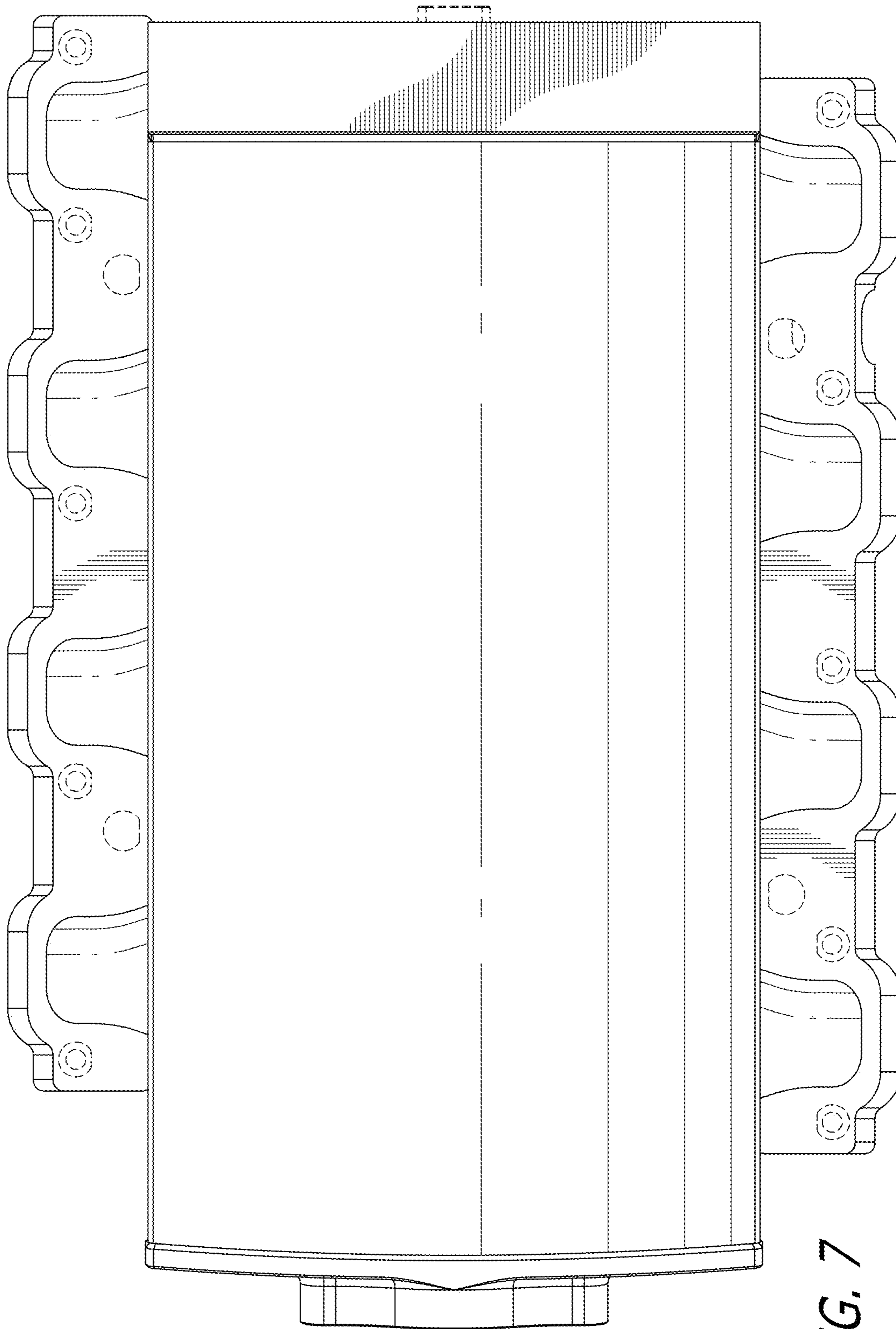

FIG. 7

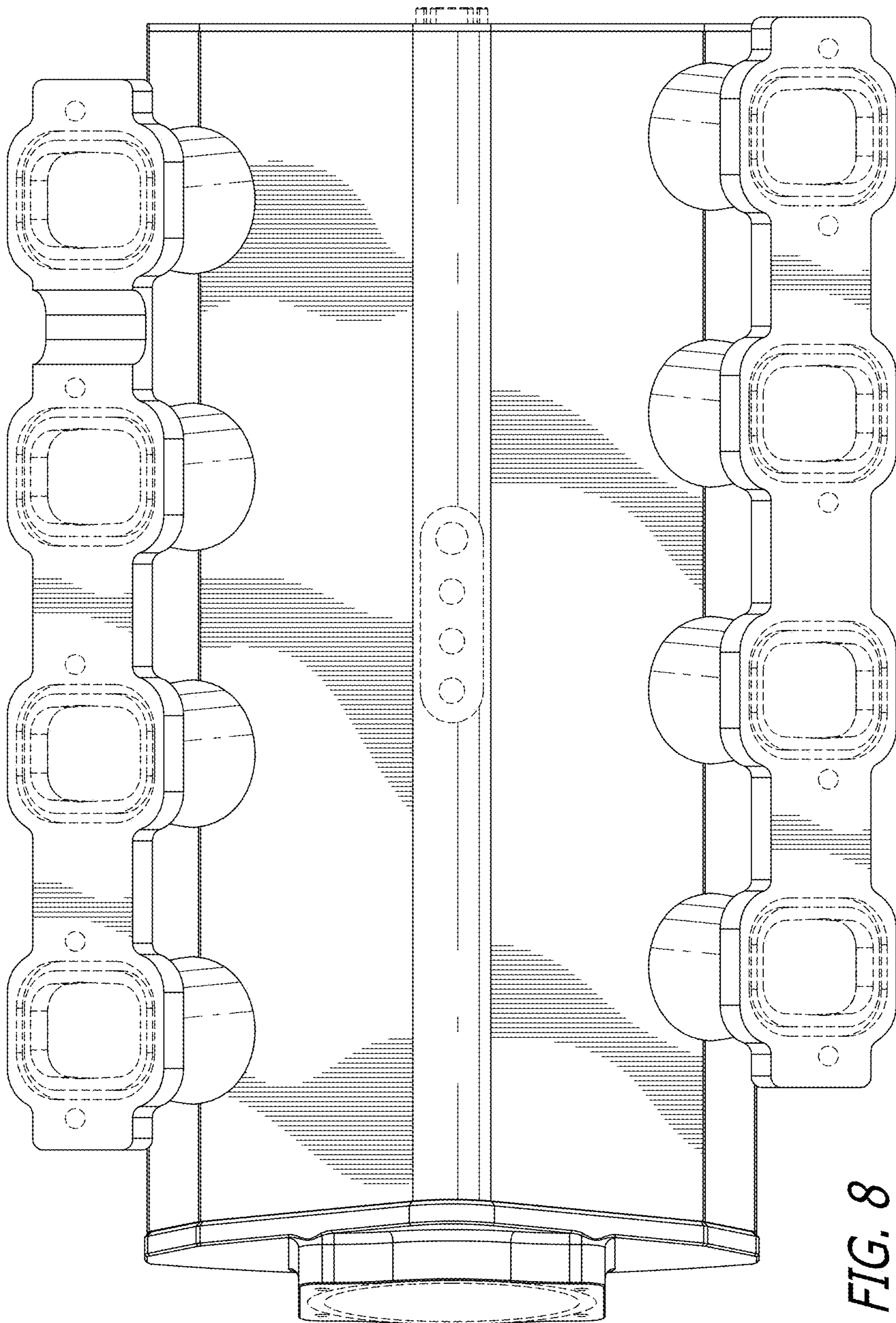

FIG. 8