



US00D957290S

(12) **United States Design Patent** (10) **Patent No.:** **US D957,290 S**
Nolte et al. (45) **Date of Patent:** **** Jul. 12, 2022**

(54) **OFF-ROAD VEHICLE BODY**
(71) Applicant: **BOMBARDIER RECREATIONAL PRODUCTS INC., Valcourt (CA)**
(72) Inventors: **Drake Nolte, London (CA); Jean-Philippe Crepeau, Bromont (CA)**
(73) Assignee: **BOMBARDIER RECREATIONAL PRODUCTS INC., Valcourt (CA)**

9,932,073 B2 * 4/2018 Dube B60K 13/02
D828,225 S 9/2018 Zhang et al.
10,207,555 B2 * 2/2019 Mailhot B60R 21/13
D852,674 S * 7/2019 Wilcox D12/87
10,369,861 B2 * 8/2019 Deckard B62D 21/183
10,399,435 B2 * 9/2019 Bastien B60K 15/03504
10,479,422 B2 * 11/2019 Hollman B60K 17/34
D879,663 S * 3/2020 Barlow, Jr. D12/87
10,607,091 B2 * 3/2020 Kawamoto G06K 9/00791
10,655,574 B2 * 5/2020 Hamada F02M 35/10288
D904,931 S * 12/2020 Lai D12/87

(**) Term: **15 Years**
(21) Appl. No.: **29/704,901**
(22) Filed: **Sep. 9, 2019**
(51) **LOC (13) Cl.** **12-08**
(52) **U.S. Cl.**
USPC **D12/87**
(58) **Field of Classification Search**
USPC D12/3, 4, 5, 14, 85, 86, 87, 107, 110
CPC ... B62D 1/04; B62D 1/18; B62D 3/12; B62D
5/0403; B62D 21/11; B62D 23/005;
B60G 3/20; B60N 2/015; B60R 21/13
See application file for complete search history.

OTHER PUBLICATIONS

Grant Decision issued from the ROSPATENT dated Sep. 14, 2020 in connection with the corresponding application No. 2020500201 and including the nearest prior art.

* cited by examiner

Primary Examiner — Darlington Ly
(74) *Attorney, Agent, or Firm* — BCF LLP

(57) **CLAIM**

The ornamental design for an off-road vehicle body, as shown and described.

DESCRIPTION

FIG. 1 is a perspective view taken from a front, left side of an off-road vehicle body according to our design; FIG. 2 is a front elevation view thereof; FIG. 3 is a rear elevation view thereof; FIG. 4 is a left side elevation view thereof; FIG. 5 is a right side elevation view thereof; FIG. 6 is a top plan view thereof; and, FIG. 7 is a bottom plan view thereof. The broken lines in the drawings illustrate portions of the off-road vehicle body that form no part of the claimed design.

1 Claim, 7 Drawing Sheets

(56) **References Cited**
U.S. PATENT DOCUMENTS
D555,036 S * 11/2007 Eck D12/87
D622,631 S * 8/2010 Lai D12/87
D642,493 S * 8/2011 Goebert D12/87
D650,311 S * 12/2011 Bracy D12/87
D703,102 S * 4/2014 Eck D12/87
8,944,449 B2 * 2/2015 Hurd B62D 21/186
280/124.152
D735,077 S * 7/2015 Sato D12/87
D737,724 S * 9/2015 Schroeder D12/87
D756,845 S * 5/2016 Flores D12/87
9,540,052 B2 * 1/2017 Burt, II B62D 33/0617
9,889,777 B2 * 2/2018 Proulx B60N 2/01

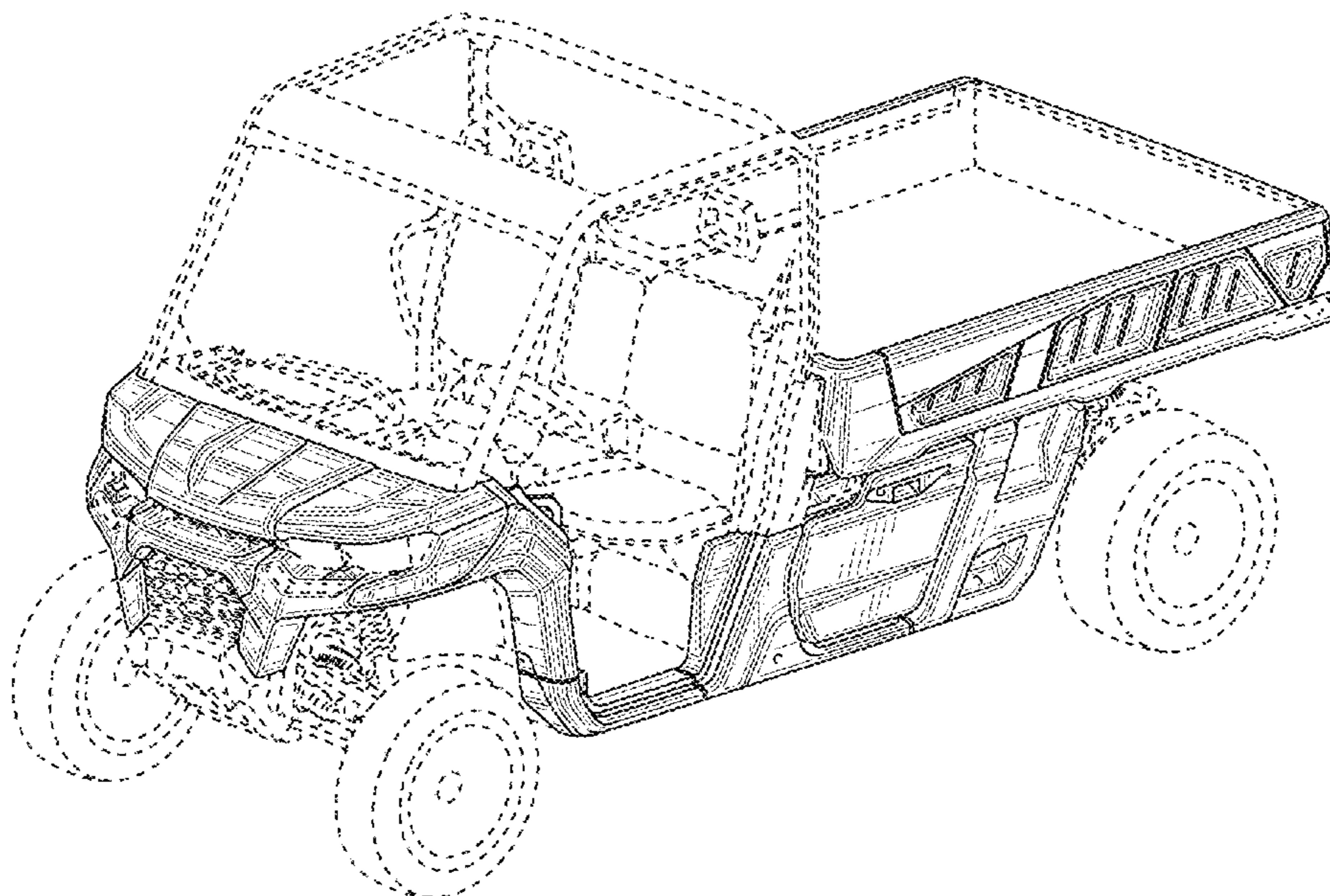

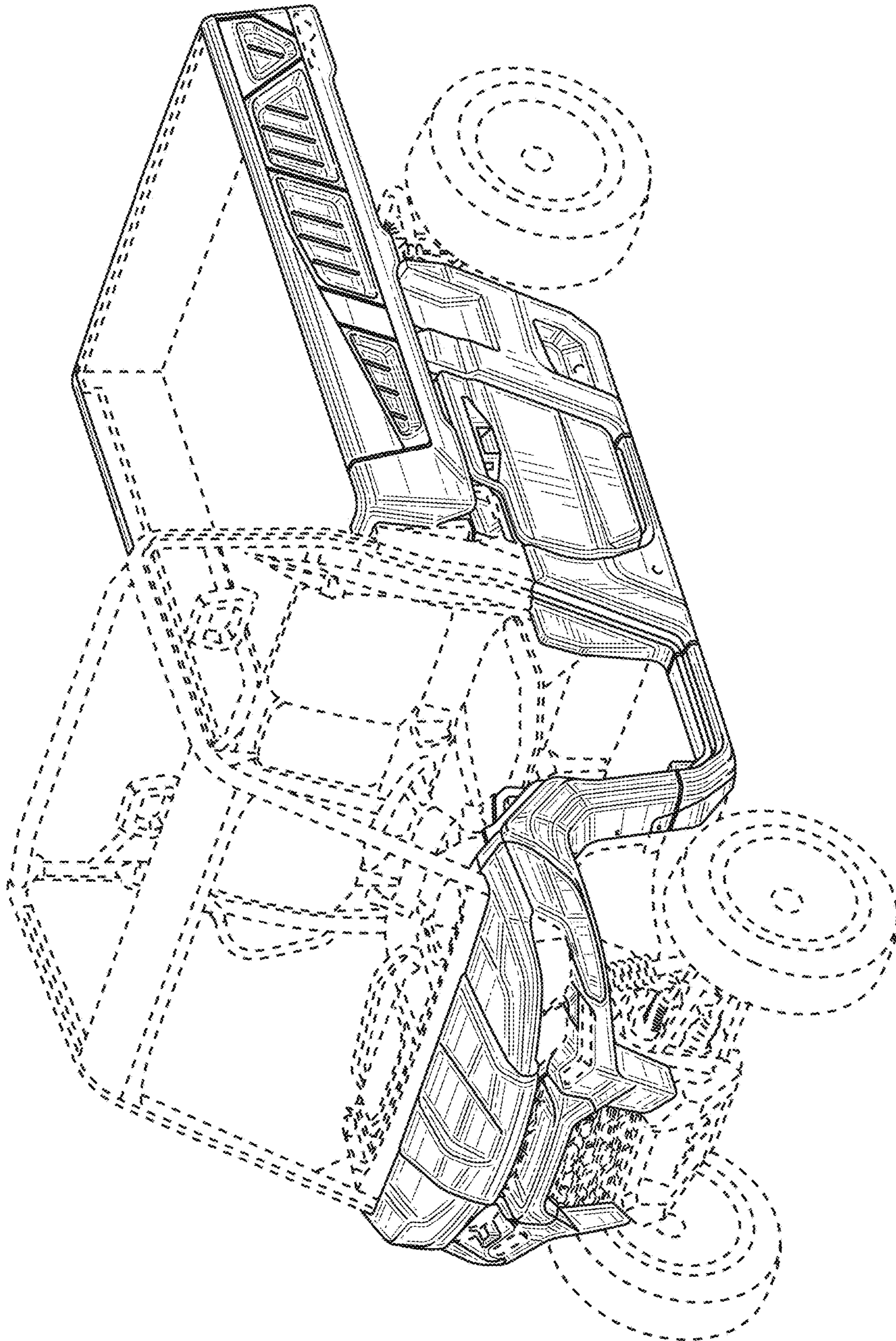

FIG. 1

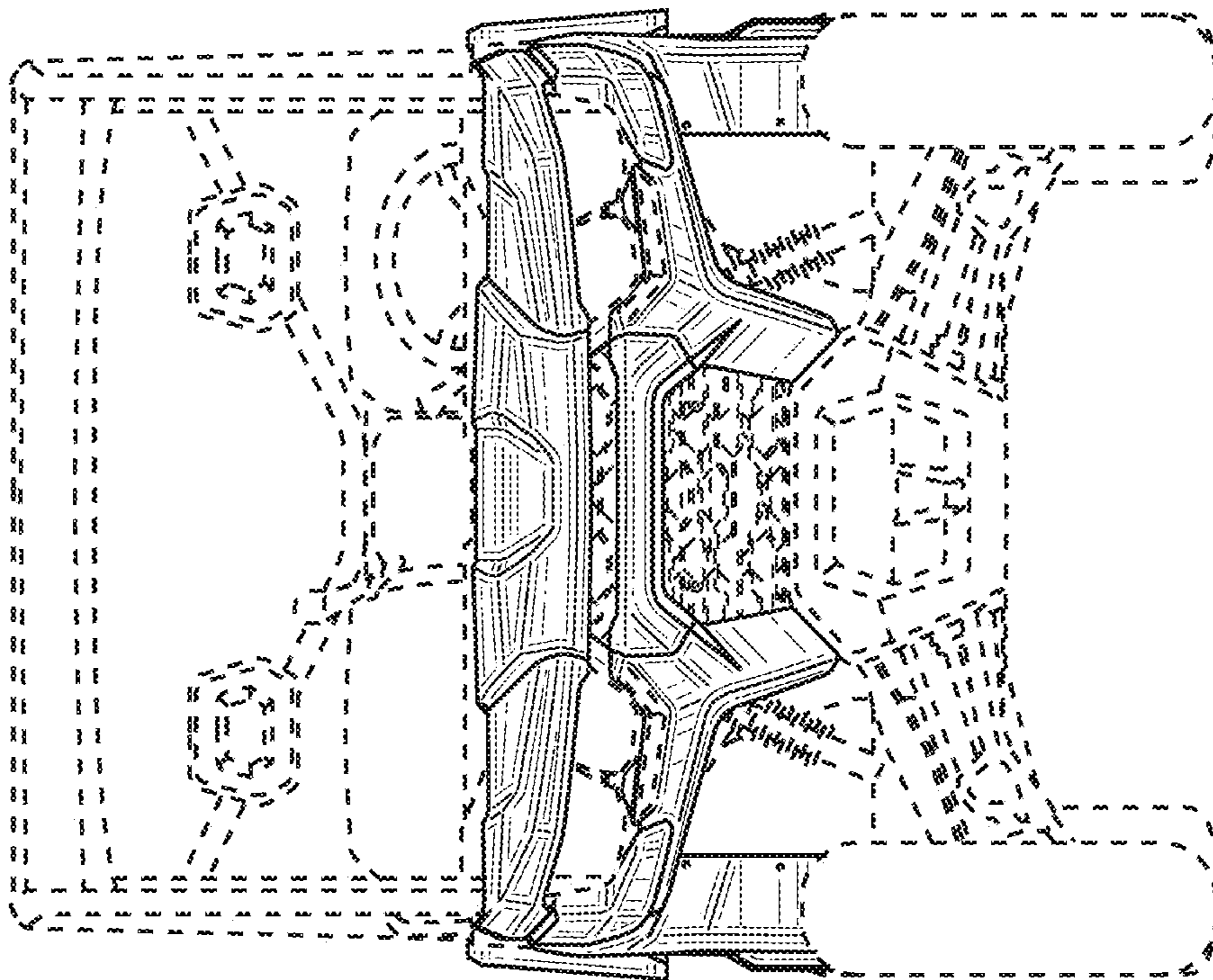

FIG. 2

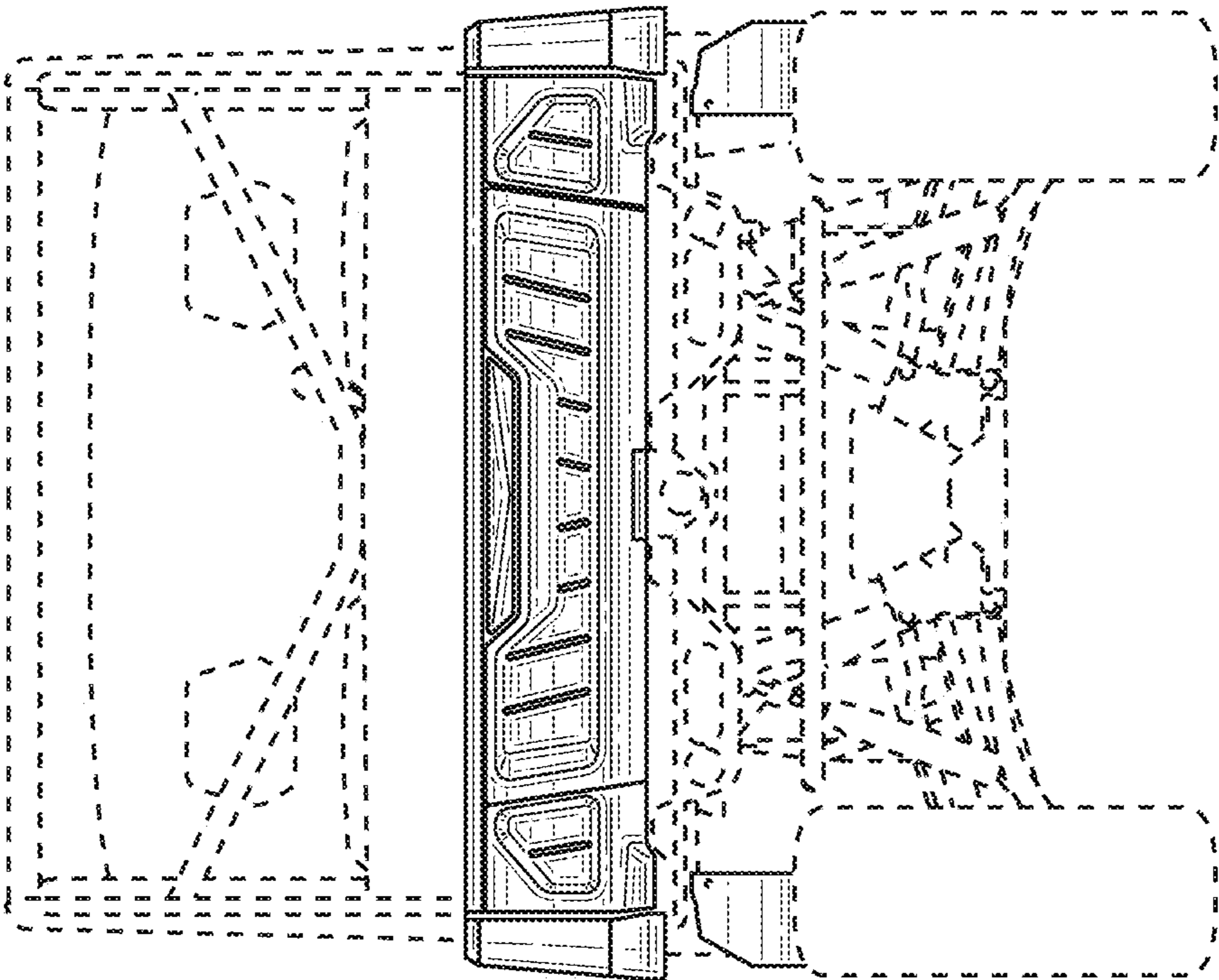

FIG. 3

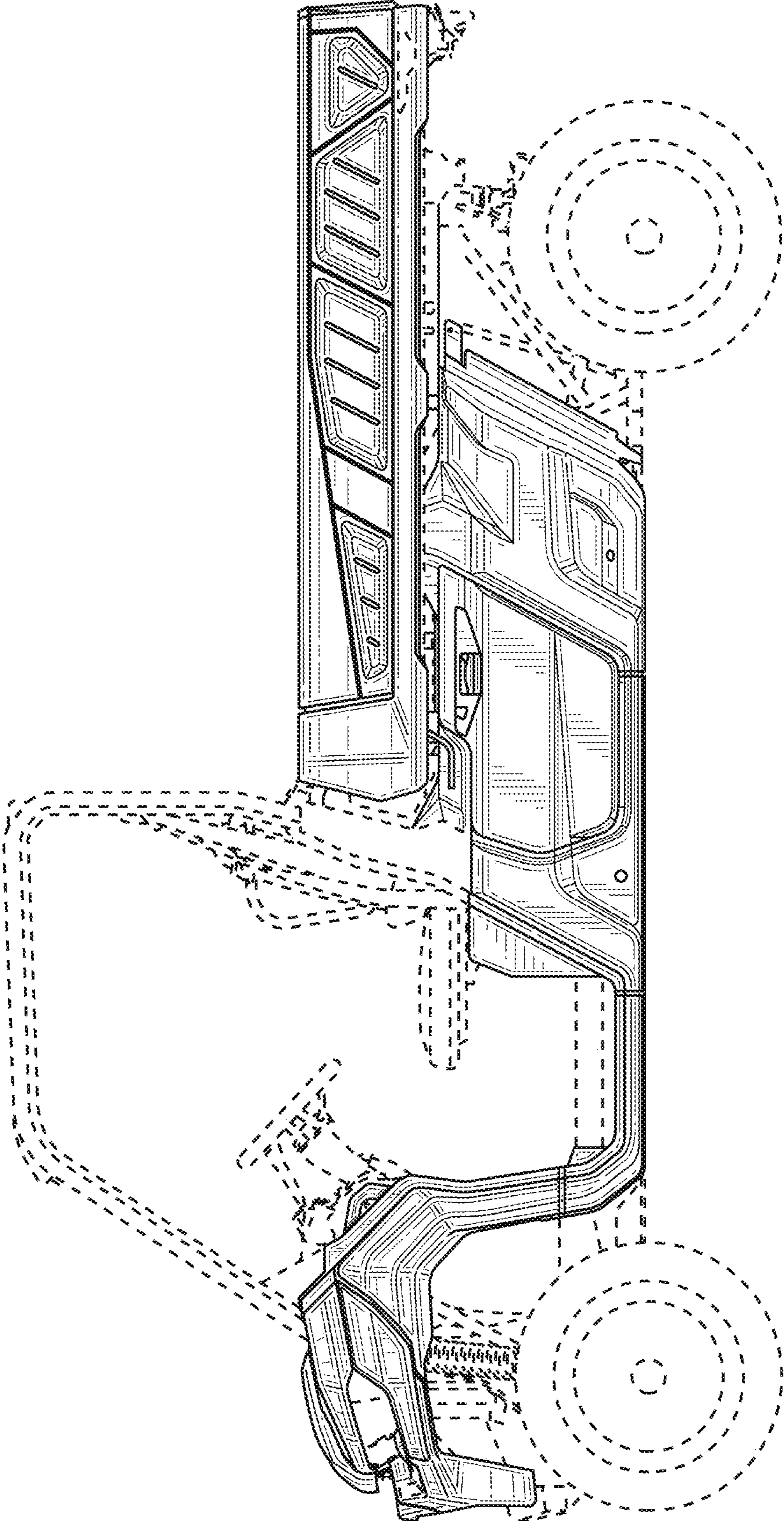

FIG. 4

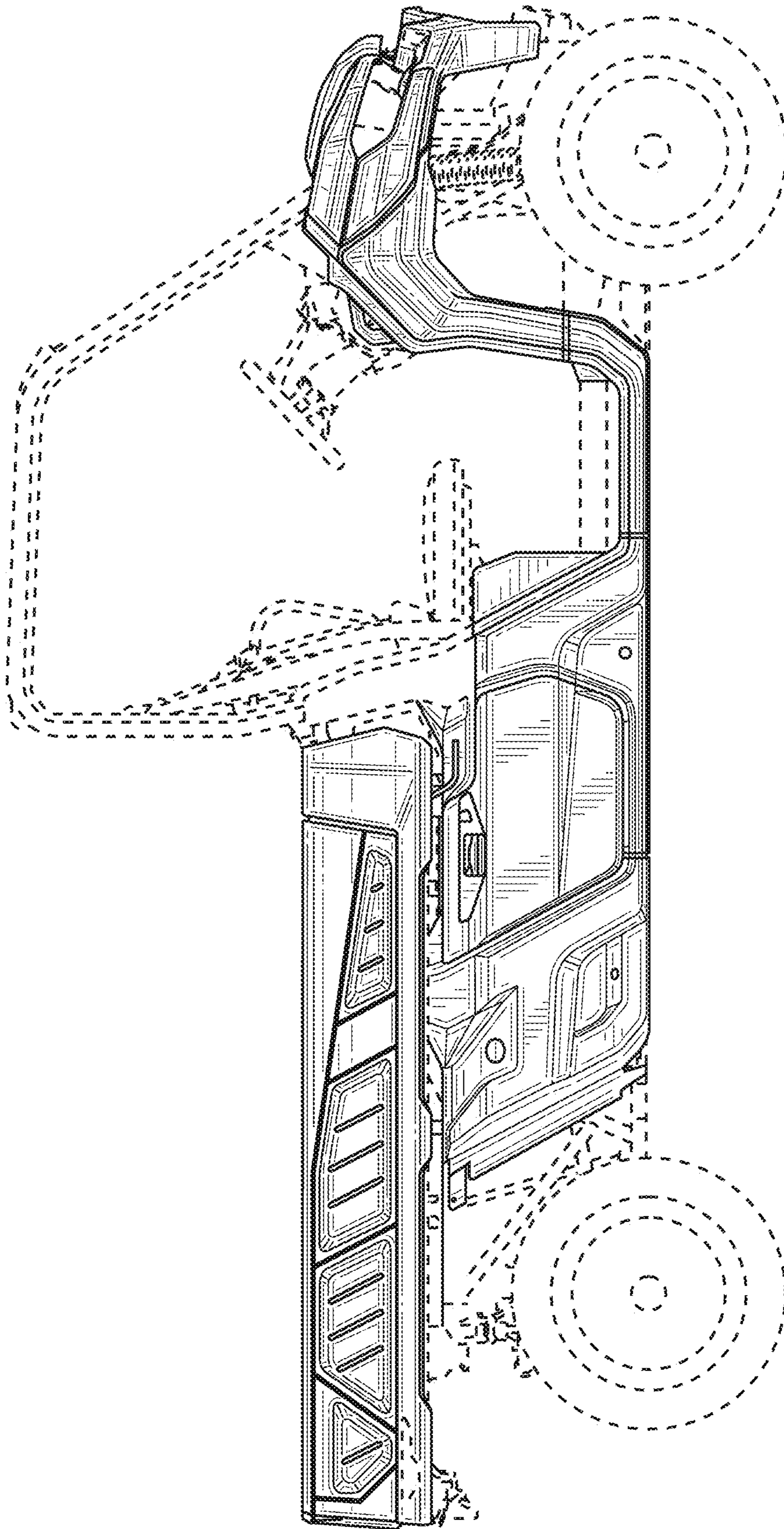

FIG. 5

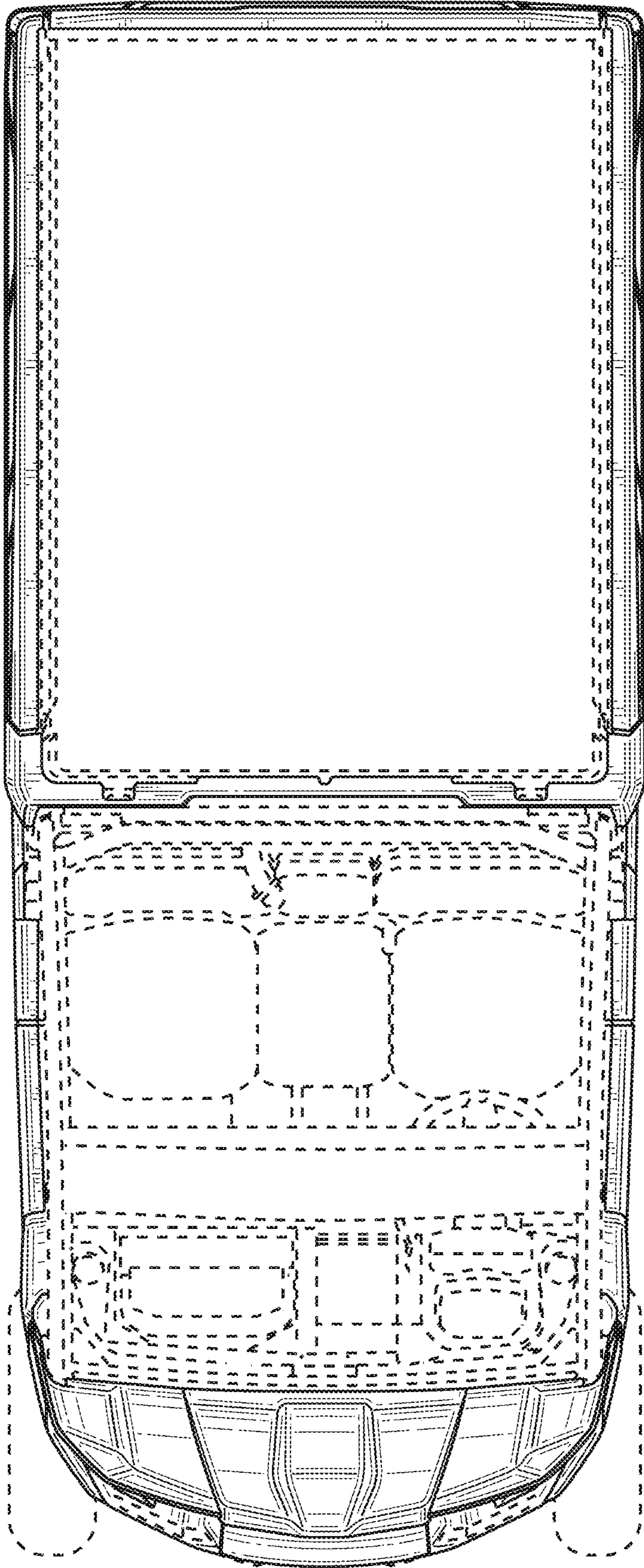

FIG. 6

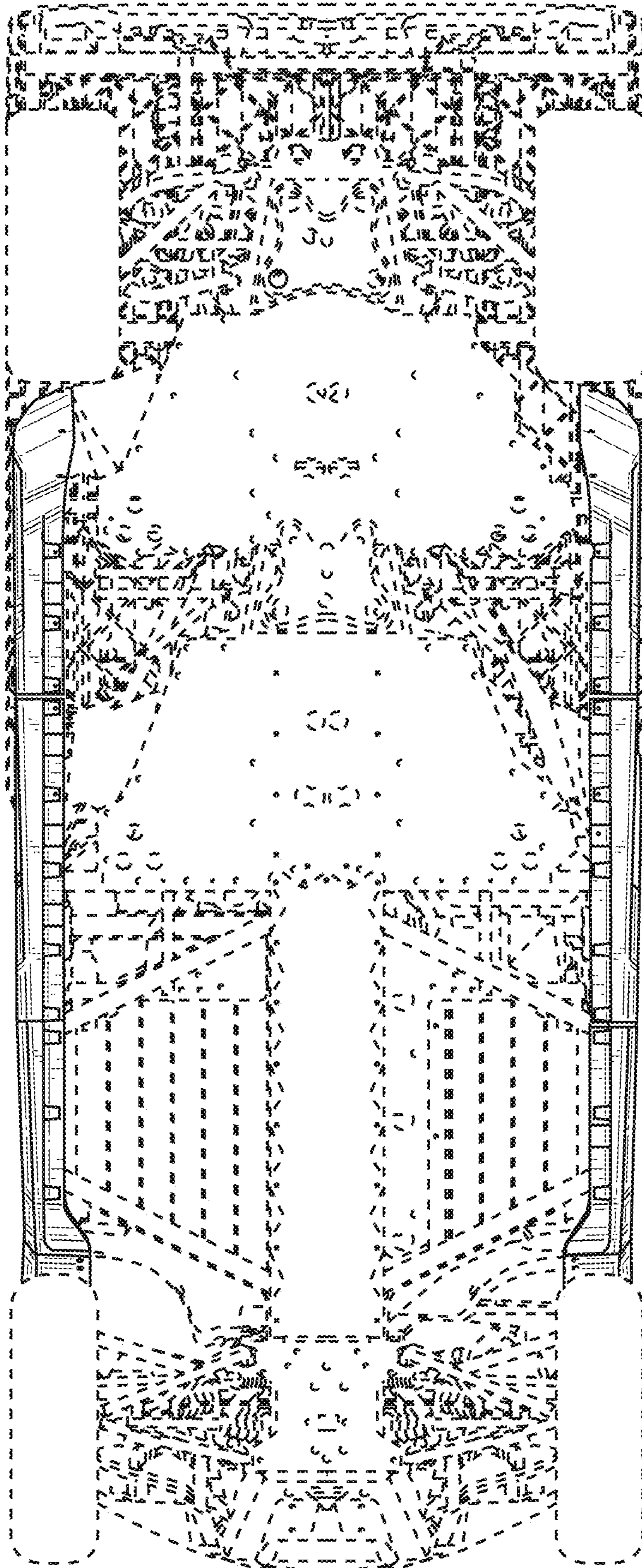

FIG. 7