



US00D957150S

(12) **United States Design Patent** (10) **Patent No.:** **US D957,150 S**
Bowers et al. (45) **Date of Patent:** **** Jul. 12, 2022**

(54) **CHILD CAR SEAT** D724,852 S * 3/2015 Giampavolo D6/333
D781,059 S * 3/2017 Christopherson D6/333
D841,991 S * 3/2019 Bowers D6/333

(71) Applicant: **Wonderland Switzerland AG**,
Steinhausen (CH)

* cited by examiner

(72) Inventors: **Patrick J. G. Bowers**, West Chester,
PA (US); **Peter Tuckey**, Leola, PA (US)

Primary Examiner — Abraham Bahta

(74) *Attorney, Agent, or Firm* — Burriss Law, PLLC

(73) Assignee: **Wonderland Switzerland AG**,
Steinhausen (CH)

(**) Term: **15 Years**

(57) **CLAIM**

(21) Appl. No.: **29/768,220**

The ornamental design for a child car seat, as shown and described.

(22) Filed: **Jan. 28, 2021**

(51) **LOC (13) Cl.** **06-01**

(52) **U.S. Cl.**
USPC **D6/333**

DESCRIPTION

(58) **Field of Classification Search**
USPC D6/333–336, 339, 344, 702, 716,
D6/716.1–716.7; 297/183.1–183.4,
297/184.13, 184.15, 184.17, 250.1, 255,
297/256.1, 256.15, 219.12, 463.1;
D12/129–130, 133; D21/412, 428, 419;
280/30–31; 5/94, 98.1, 99.1, 101–102,
5/105, 655, 93.1, 12.1; 24/200
CPC A47D 13/02; A47D 13/10; A47D 13/083;
A47D 1/00; A47D 1/002; A47D 1/004;
A47D 1/008; A47D 1/04; B60N 2/22;
B60N 2/24; B60N 2/2821; B60N 2/02;
B60N 2/10; B60N 2/16; B60N
2002/0212; B60N 2002/0216; B60N
2002/022; A47C 3/00; A47C 3/02; A47C
3/025; A47C 3/20

FIG. 1 is a perspective view of a child car seat showing our new design;
FIG. 2 is a front elevational view thereof;
FIG. 3 is a rear elevational view thereof;
FIG. 4 is a left side elevational view thereof;
FIG. 5 is a right side elevational view thereof;
FIG. 6 is a top plan view thereof;
FIG. 7 is a bottom plan view thereof;
FIG. 8 is a perspective view of the design with broken line environment;
FIG. 9 is a perspective view of the design in a state of use with broken line environment; and,
FIG. 10 is another perspective view of the design in a state of use with broken line environment.

See application file for complete search history.

The dashed broken lines depict portions of a child car seat in which the design is embodied that form no part of the claimed design, and illustrate environment structures that form no part of the claimed design.

The dot-dash broken lines are for defining the bounds of the claimed design only and form no part of the claimed design.

(56) **References Cited**

U.S. PATENT DOCUMENTS

D417,568 S * 12/1999 Pike D6/333
D555,402 S * 11/2007 Hou D6/708.19

1 Claim, 10 Drawing Sheets

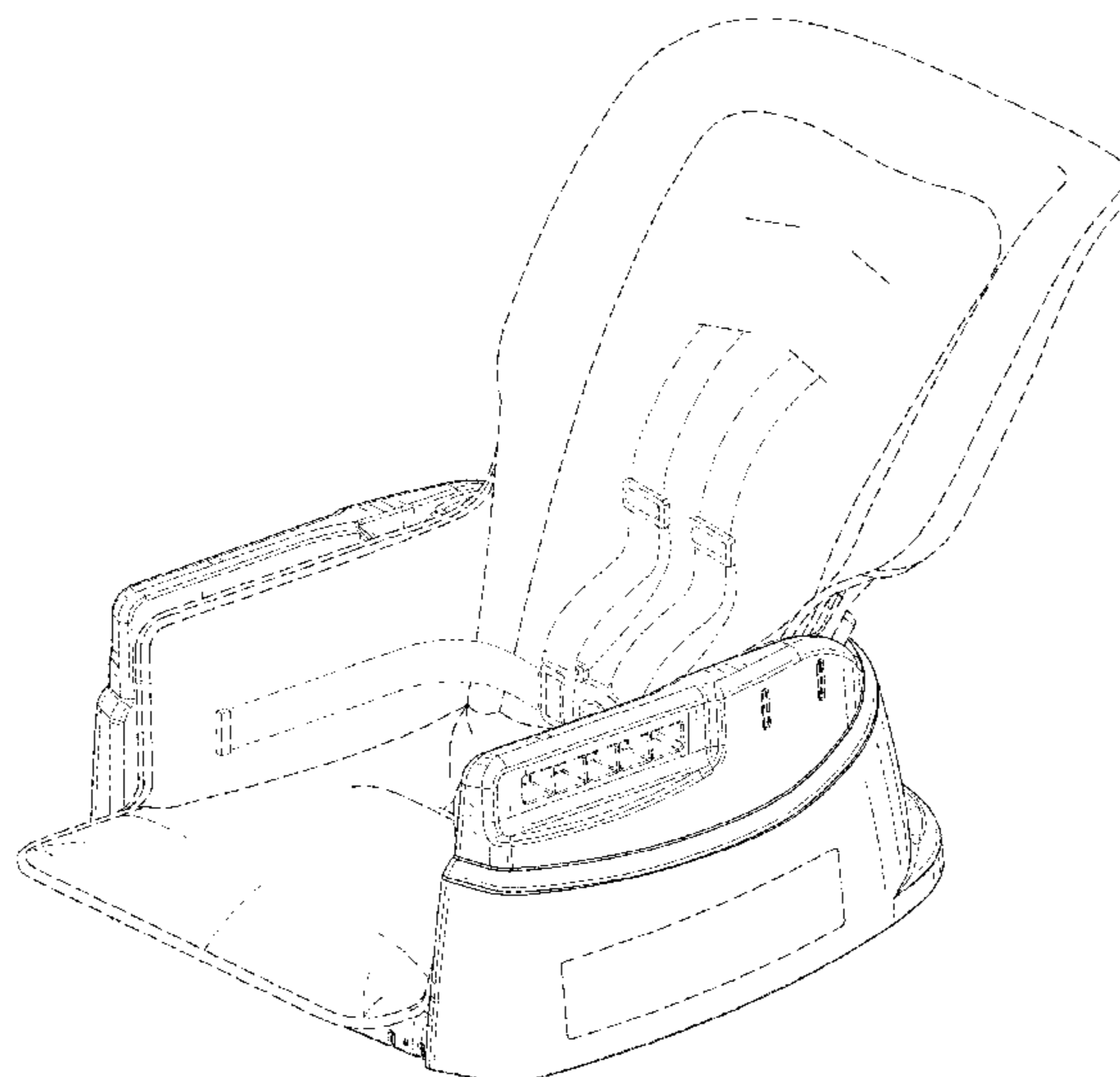

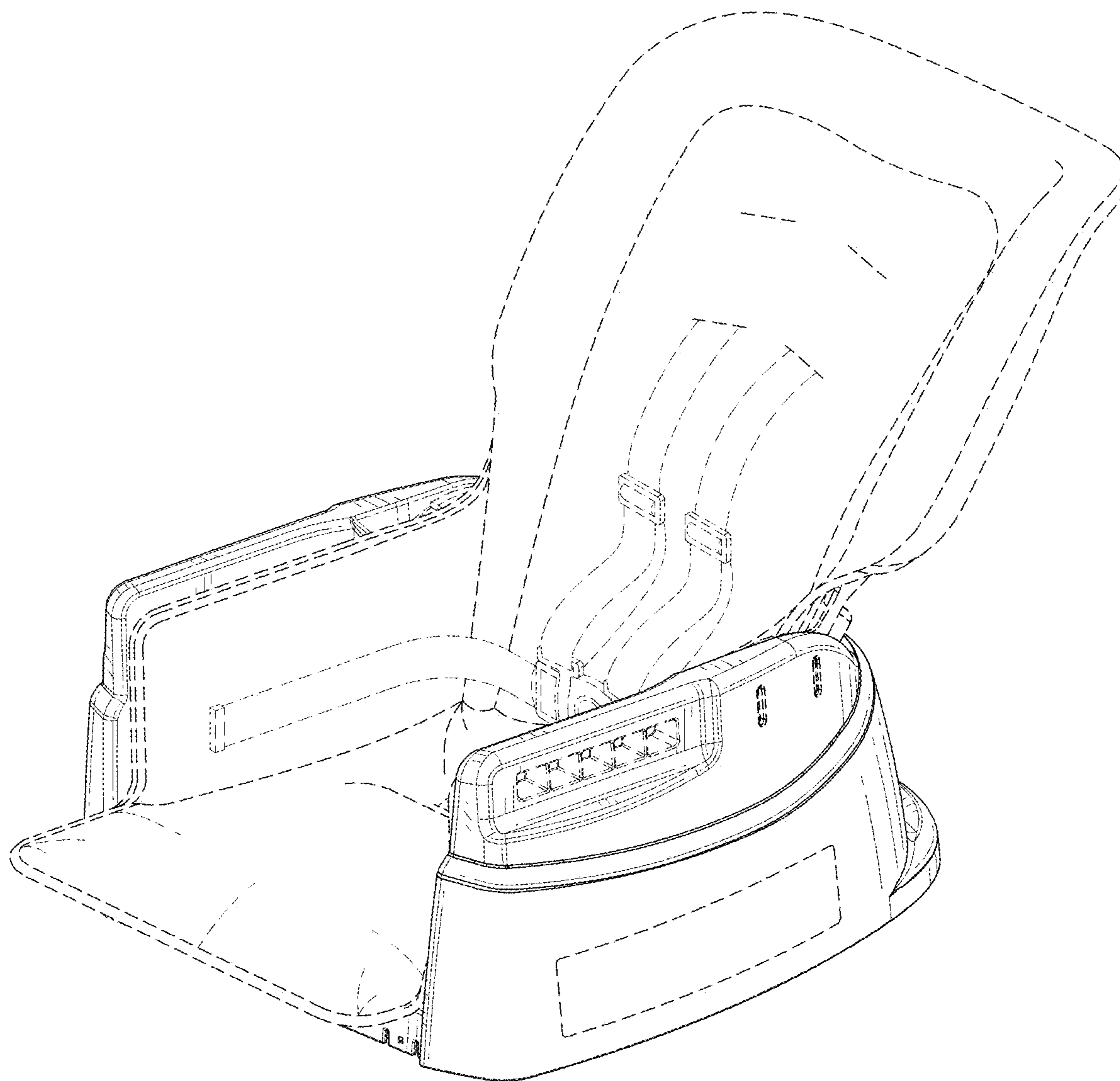

FIG. 1

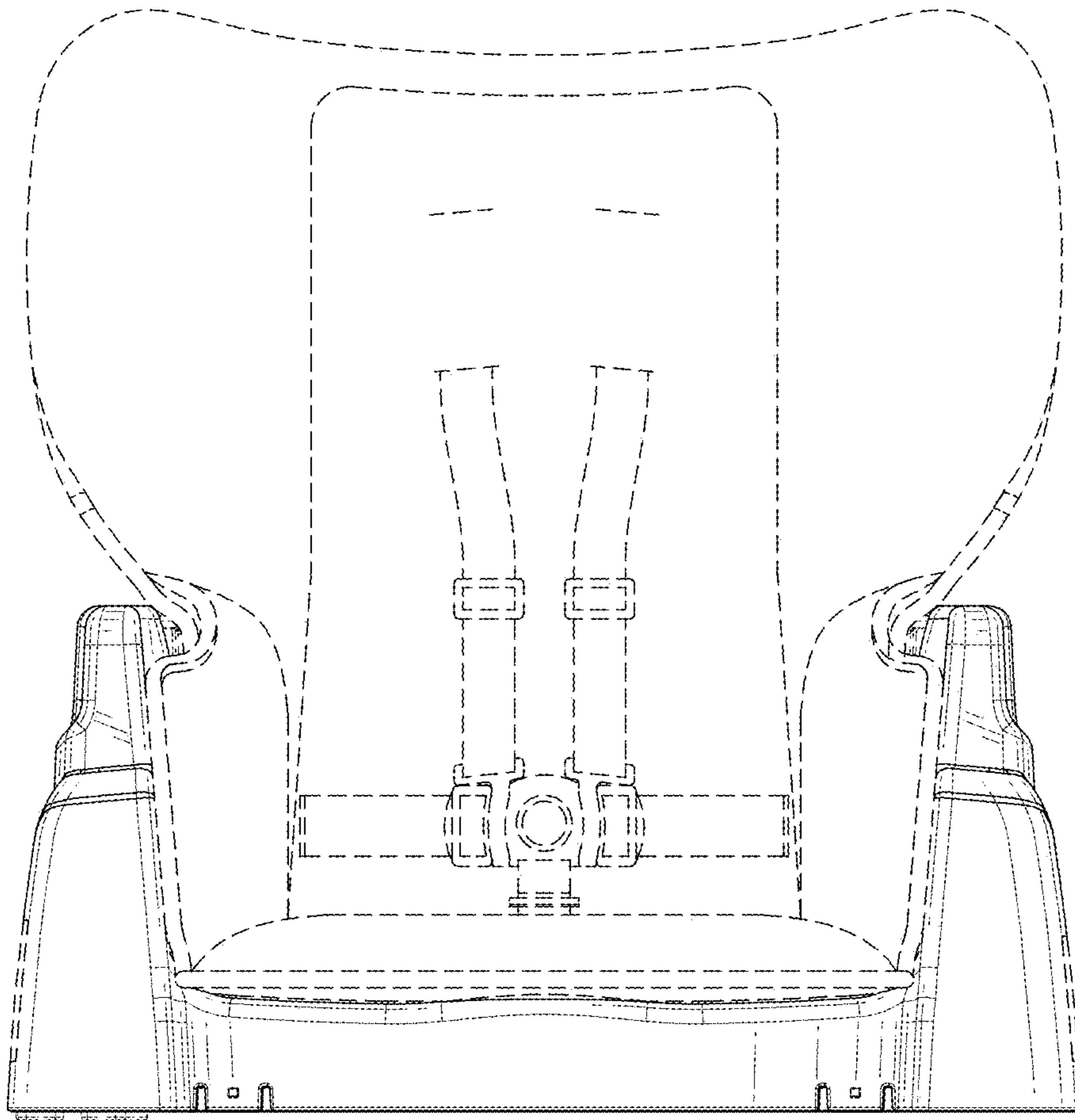

FIG. 2

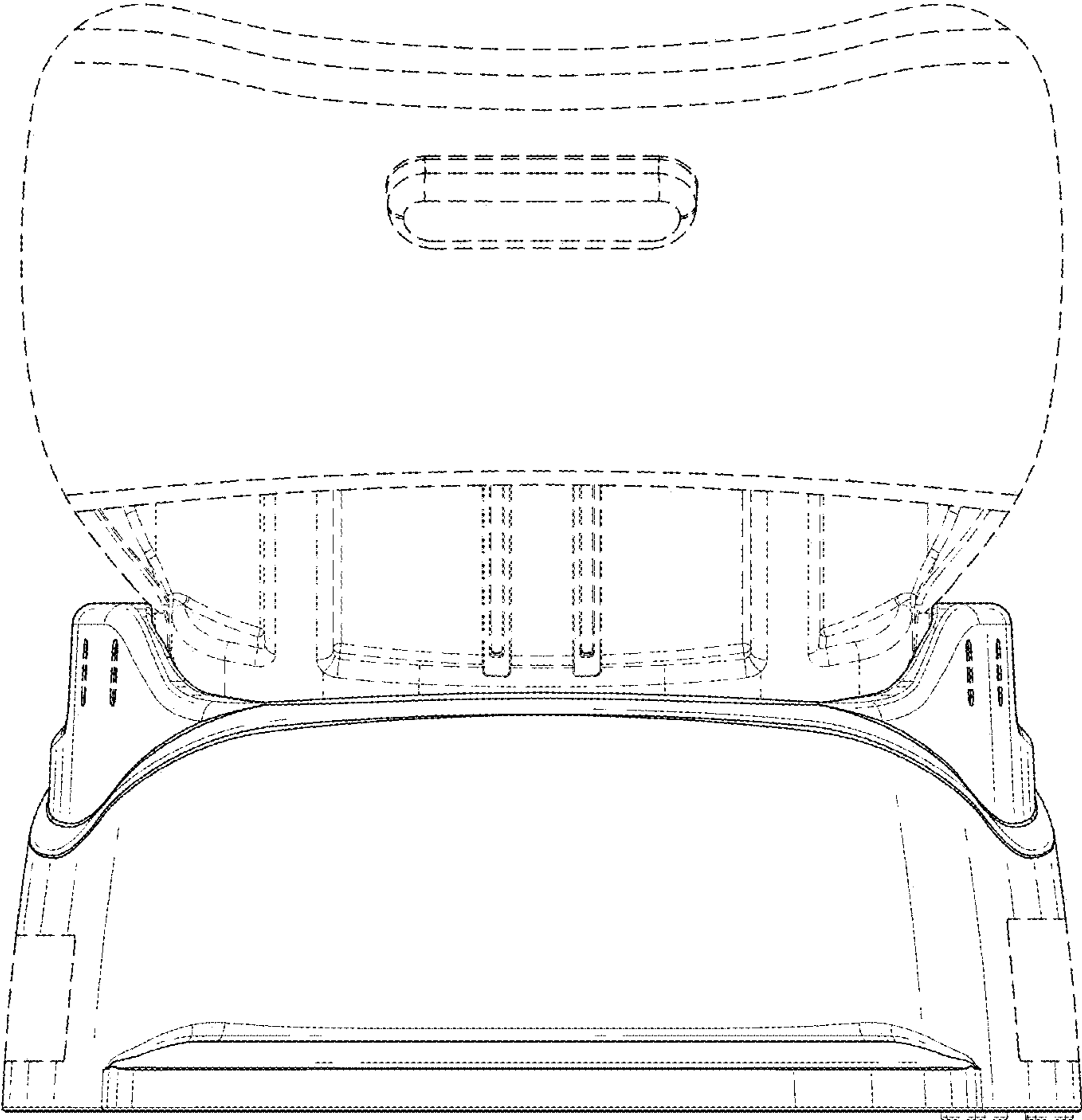

FIG. 3

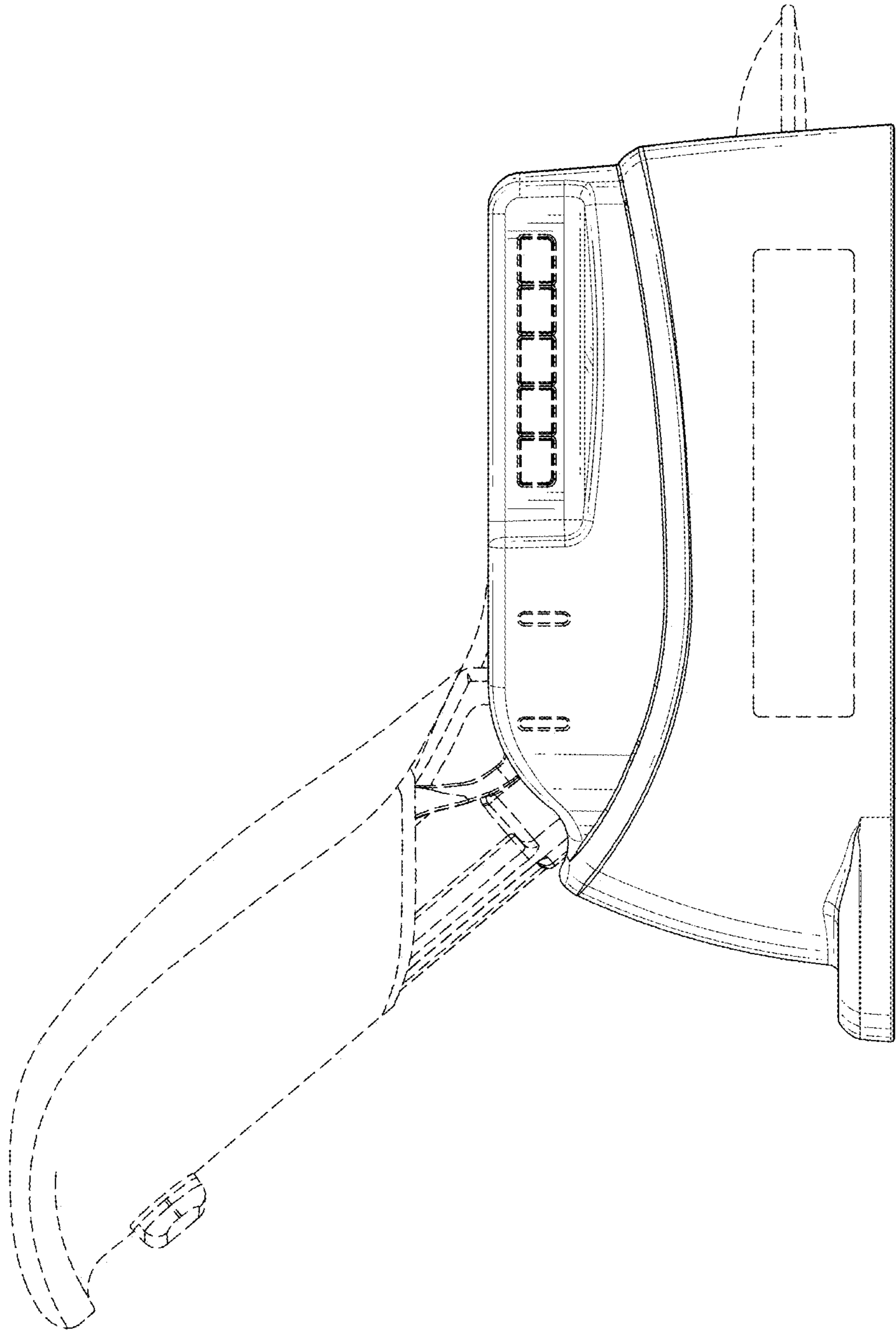

FIG. 4

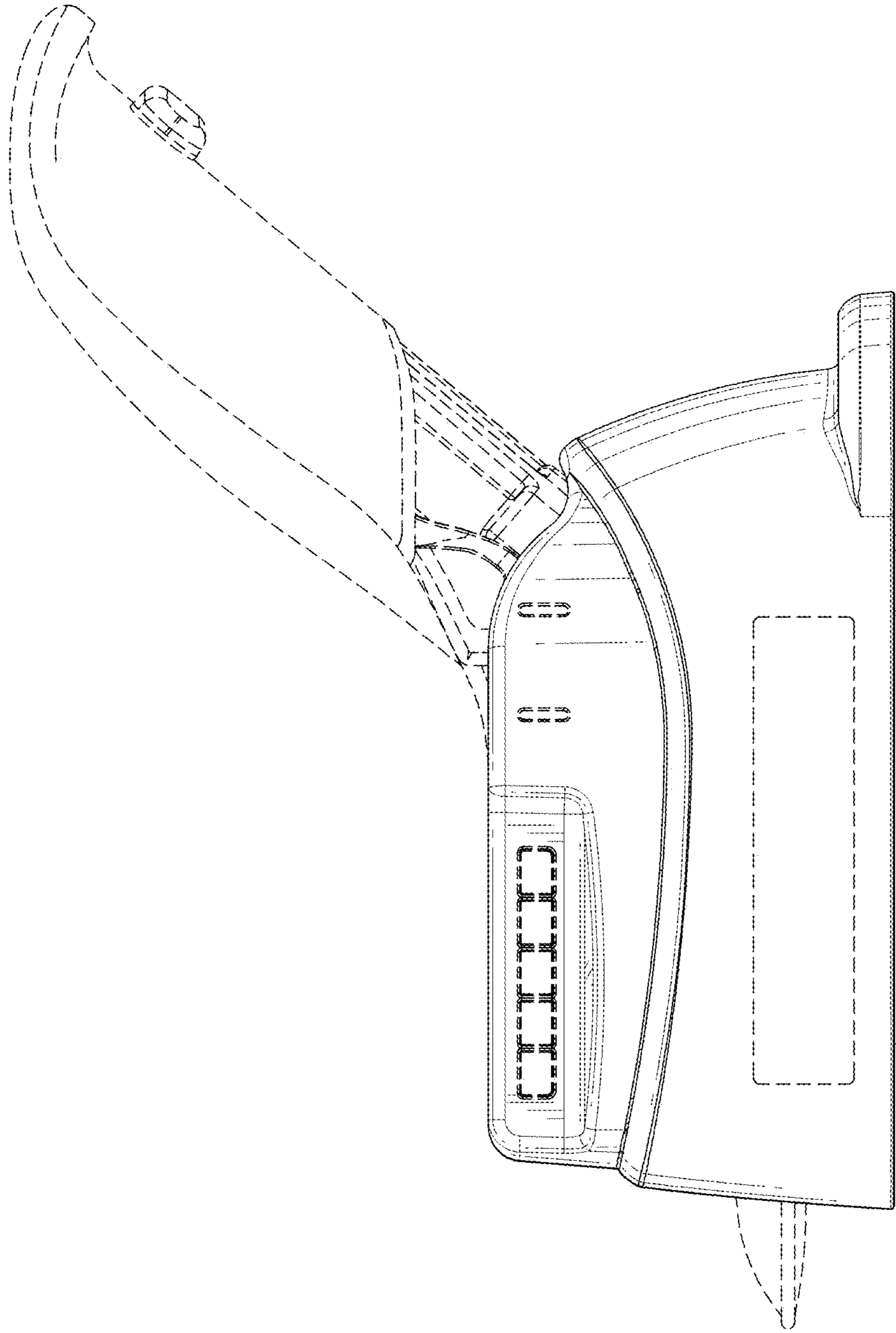

FIG. 5

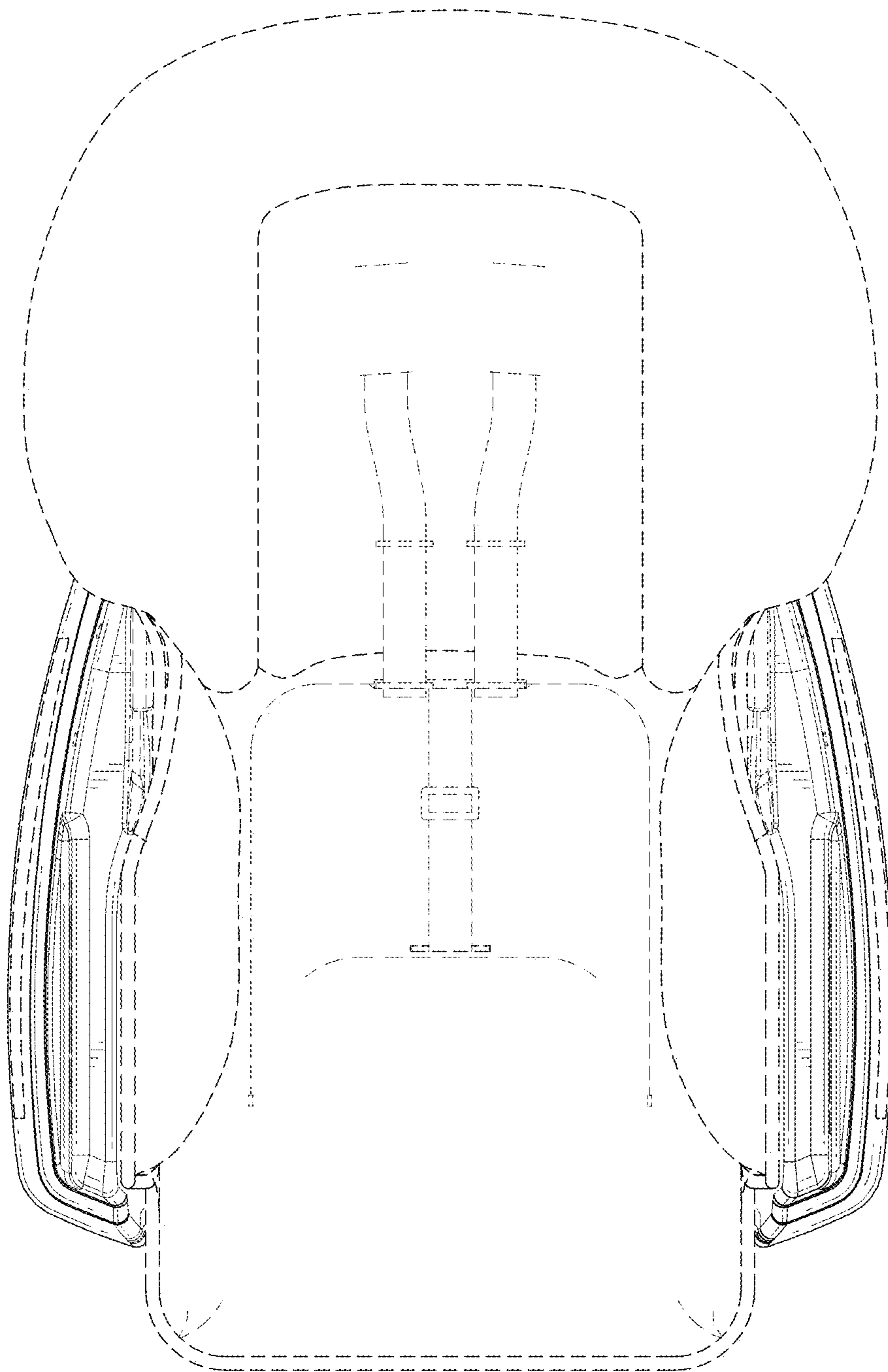

FIG. 6

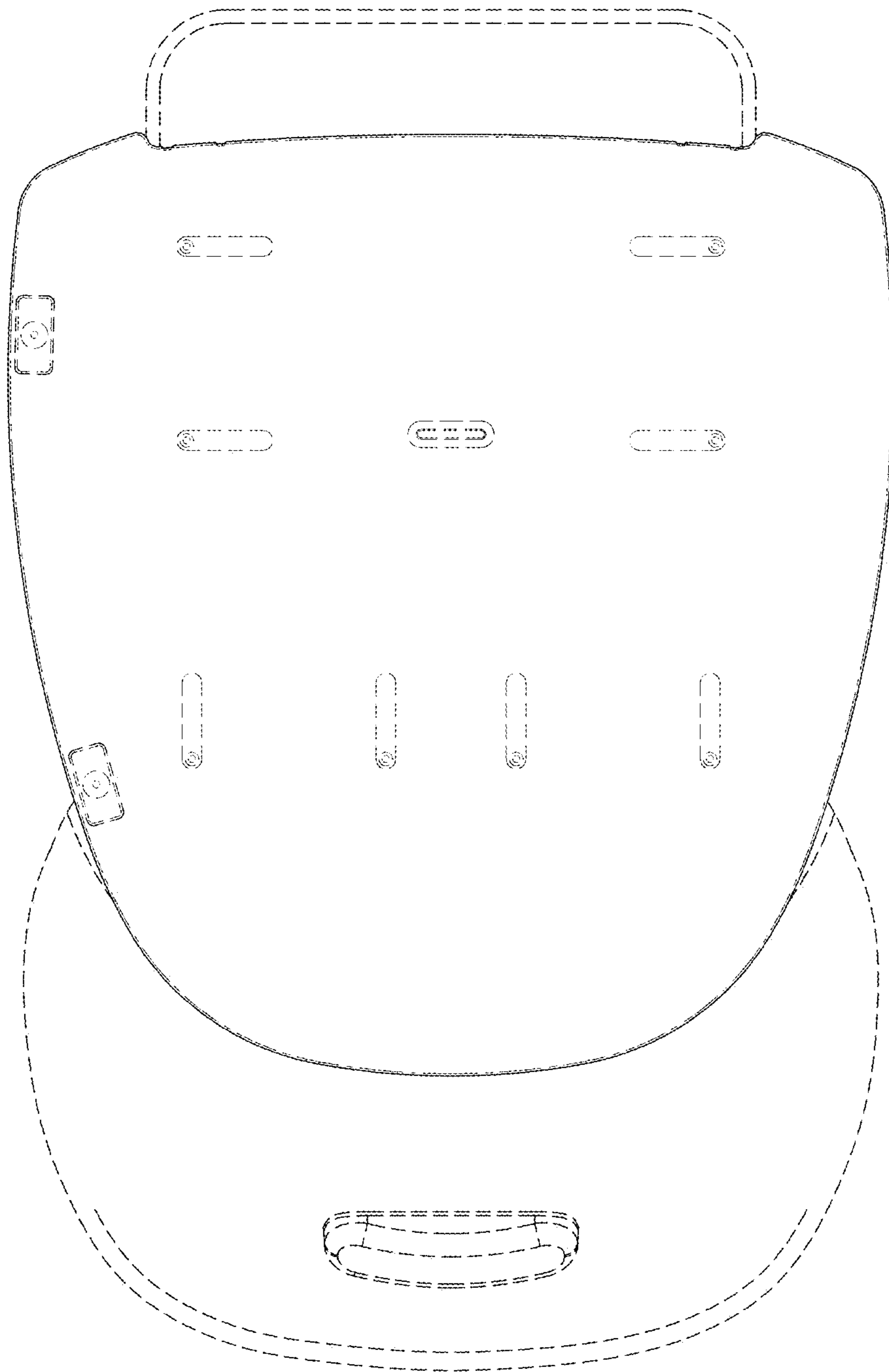

FIG. 7

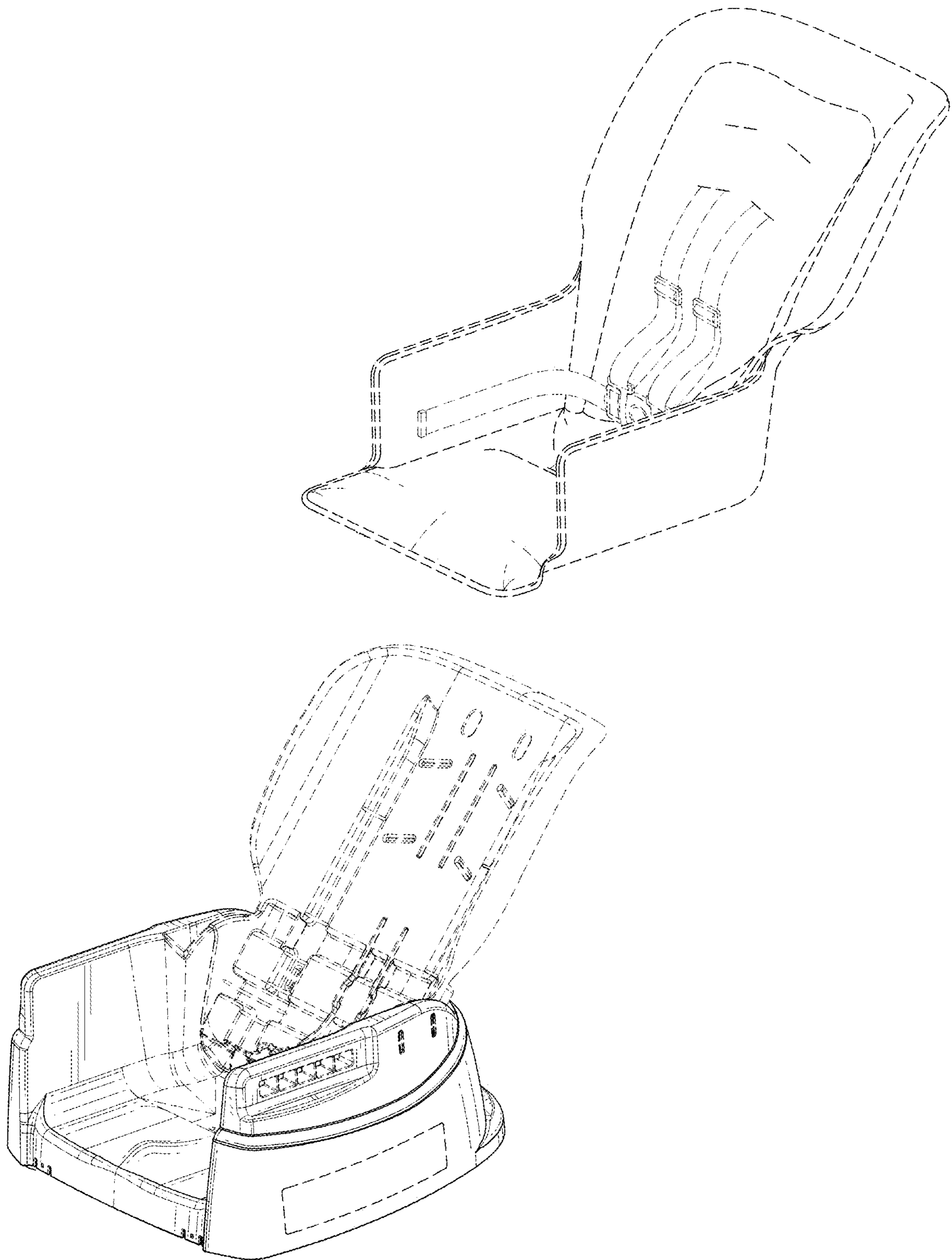

FIG. 8

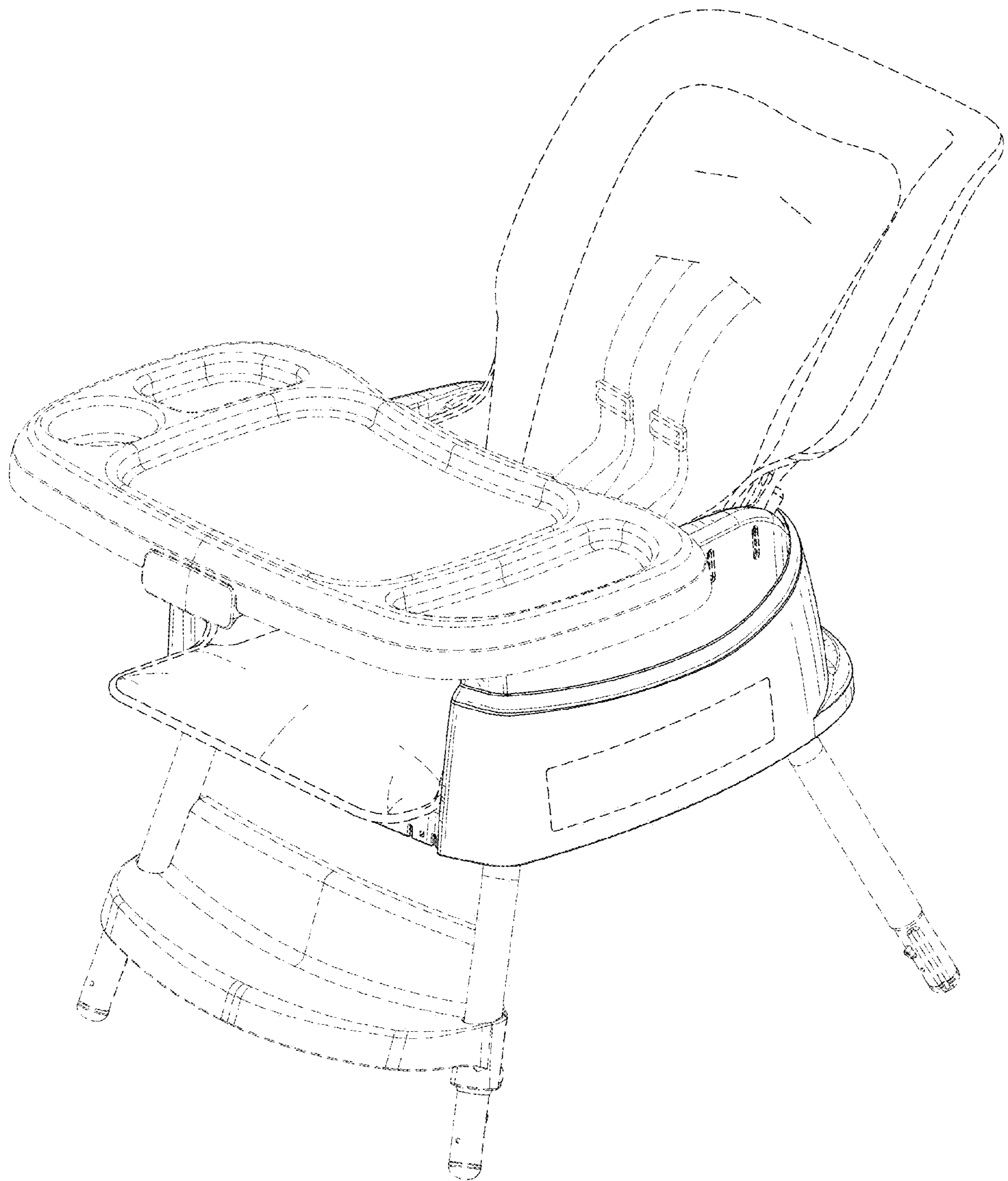

FIG. 9

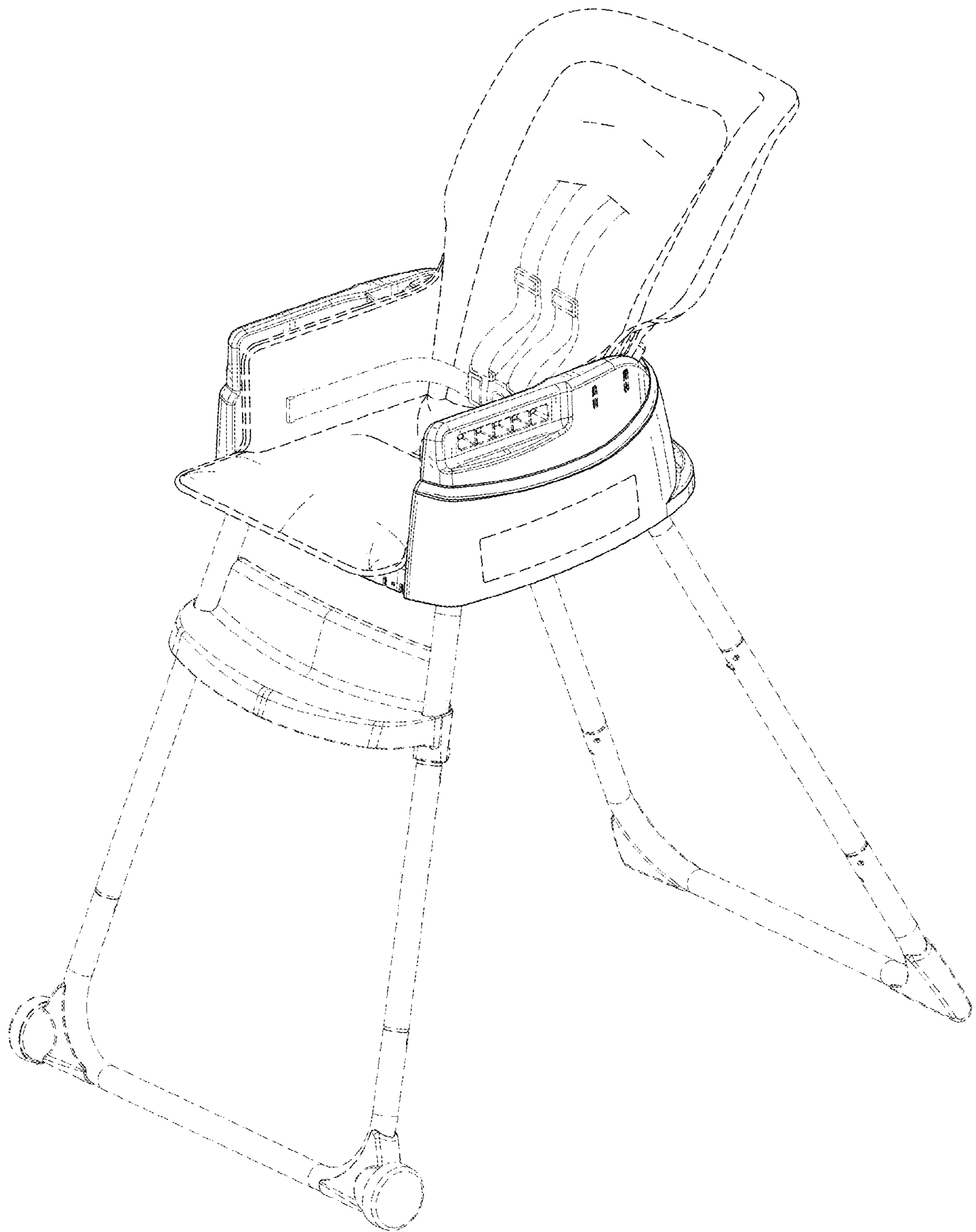

FIG. 10