



US00D956958S

(12) **United States Design Patent** (10) **Patent No.:** **US D956,958 S**
Bar-El et al. (45) **Date of Patent:** **** Jul. 5, 2022**

(54) **LIQUID TRANSFER DEVICE** 2,830,587 A 4/1958 James
 2,931,668 A 4/1960 Baley
 (71) Applicant: **WEST PHARMA. SERVICES IL, LTD.**, Ra'anana (IL) 2,968,497 A 1/1961 Mervyn
 3,059,643 A 10/1962 Barton
 (Continued)

(72) Inventors: **Yossi Bar-El**, Beit Arye (IL); **Elisheva Fabrikant**, Herzliya (IL); **Niv Ben Shalom**, Netanya (IL)

FOREIGN PATENT DOCUMENTS

CA 2946559 A1 10/2015
 CN 1636605 A 7/2005
 (Continued)

(73) Assignee: **West Pharma. Services IL, Ltd.**, Ra'anana (IL)

OTHER PUBLICATIONS

Author unknown, Progressive Medical inc. is proud to announce the launch of West's Vial2Bag Advanced, Progressive Medinc., [Post Date Oct. 23, 2020], [Site seen Jan. 25, 2022], Seen at URL: <https://www.progressivemedinc.com/west-launches-vial2bag-advanced-20mm-admixture-device/> (Year: 2020).*

(**) Term: **15 Years**

(21) Appl. No.: **29/741,476**

(22) Filed: **Jul. 13, 2020**

(51) **LOC (13) Cl.** **24-02**

(52) **U.S. Cl.**
USPC **D24/112**

(58) **Field of Classification Search**
USPC D24/100, 102, 103, 220, 221, 231, 232, D24/127-131, 112-114

CPC .. A61M 5/162; A61M 39/105; A61M 39/223; A61M 2039/0027; A61J 1/2089; A61J 1/2058

See application file for complete search history.

(Continued)

Primary Examiner — Natasha Vujcic
Assistant Examiner — Gilbert B Ford

(74) *Attorney, Agent, or Firm* — BakerHostetler

(57) **CLAIM**

We claim, the ornamental design for a liquid transfer device, as shown and described.

DESCRIPTION

FIG. 1 is a rear perspective view of a liquid transfer device;
 FIG. 2 is a front view thereof;
 FIG. 3 is a rear view thereof;
 FIG. 4 is a left side view thereof;
 FIG. 5 is a right side view thereof;
 FIG. 6 is a top view thereof; and,
 FIG. 7 is a bottom view thereof.

The broken lines in the figures show portions of the liquid transfer device that form no part of the claimed design.

1 Claim, 7 Drawing Sheets

(56) **References Cited**

U.S. PATENT DOCUMENTS

62,333 A	2/1867	Hall
247,975 A	10/1881	Wickes
254,444 A	2/1882	Vogel et al.
300,060 A	6/1884	Ford
1,021,681 A	3/1912	Jennings
1,704,817 A	3/1929	Ayers
1,930,944 A	10/1933	Schmitz, Jr.
2,326,490 A	8/1943	Perelson
2,560,162 A	7/1951	Ferguson
2,748,769 A	6/1956	Jennie

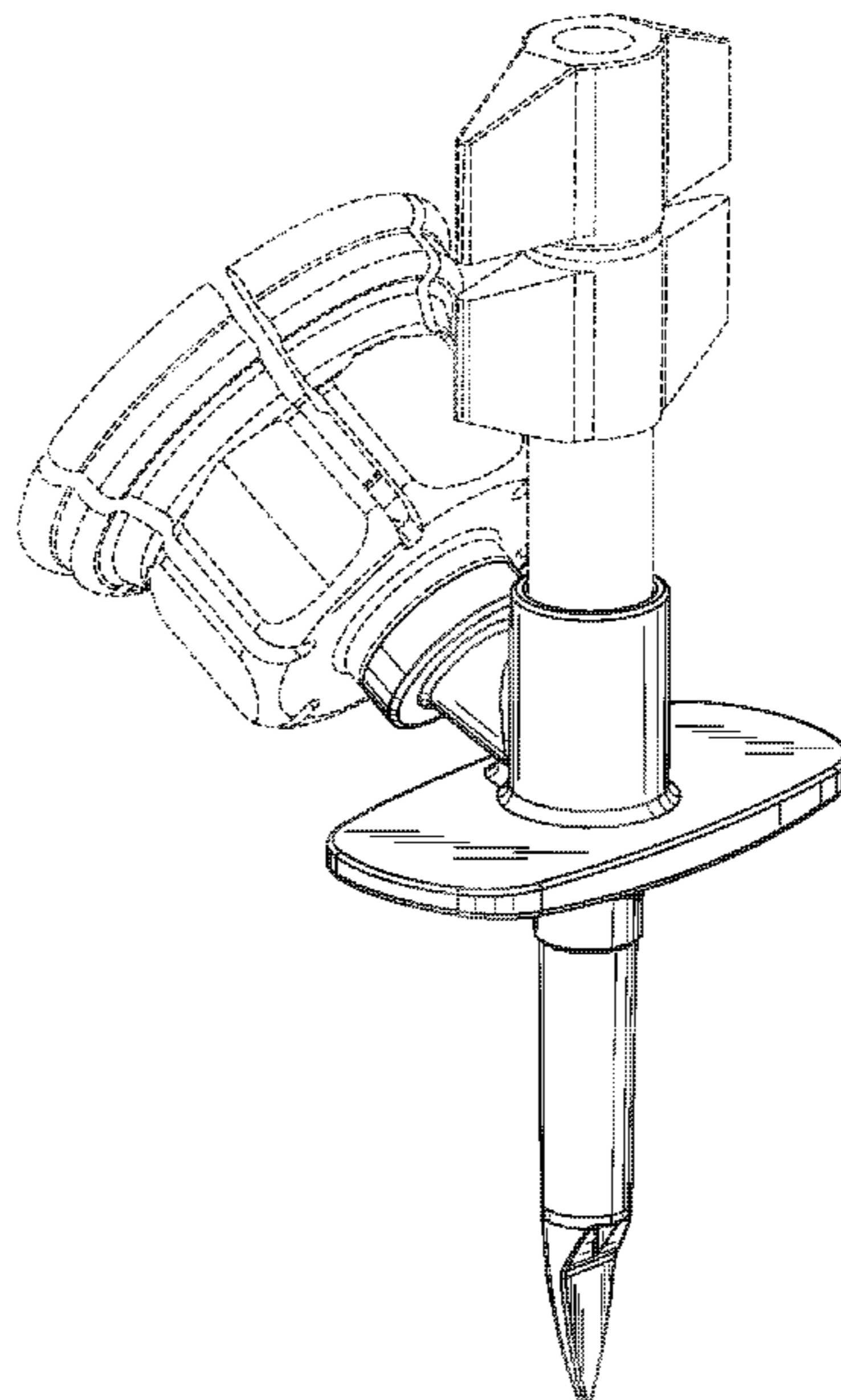

(56)

References Cited

U.S. PATENT DOCUMENTS

D198,499 S	6/1964	Andrew et al.	4,676,530 A	6/1987	Nordgren et al.
3,225,763 A	12/1965	Waterman	D291,490 S *	8/1987	Raines D24/112
3,277,893 A	10/1966	Clark	4,683,975 A	8/1987	Booth et al.
3,308,822 A	3/1967	De Luca	4,697,622 A	10/1987	Swift et al.
3,484,849 A	12/1969	Huebner et al.	4,721,133 A	1/1988	Sundblom
3,618,637 A	11/1971	Santomieri	4,729,401 A	3/1988	Raines
3,757,981 A	9/1973	Harris, Sr. et al.	4,735,608 A	4/1988	Sardam
D229,518 S *	12/1973	Bujan D24/114	4,743,229 A	5/1988	Chu
3,782,365 A	1/1974	Pinna	4,743,243 A	5/1988	Vaillancourt
3,788,524 A	1/1974	Davis et al.	4,752,292 A	6/1988	Lopez et al.
3,822,700 A	7/1974	Pennington	4,758,235 A	7/1988	Tu
3,826,261 A	7/1974	Killinger	4,759,756 A	7/1988	Forman et al.
3,872,992 A	3/1975	Larson	4,778,447 A	10/1988	Velde et al.
3,885,607 A	5/1975	Peltier	4,787,898 A	11/1988	Raines
3,938,520 A	2/1976	Scislowicz et al.	4,797,898 A	1/1989	Martinez
3,957,052 A	5/1976	Topham	D300,060 S	2/1989	Molgaard-Nielsen
3,977,555 A	8/1976	Larson	4,804,366 A	2/1989	Zdeb et al.
3,993,063 A	11/1976	Larrabee	4,826,492 A	5/1989	Magasi
4,020,839 A	5/1977	Klapp	4,832,690 A	5/1989	Kuu
4,026,128 A	5/1977	Blanco	4,834,152 A	5/1989	Howson et al.
4,051,852 A	10/1977	Villari	4,834,744 A	5/1989	Ritson
D247,975 S	5/1978	Luther	D303,013 S	8/1989	Konopka
D248,568 S	7/1978	Ismach	4,857,062 A	8/1989	Russell
4,109,670 A	8/1978	Slagel	4,865,592 A	9/1989	Rycroft
4,121,585 A	10/1978	Becker, Jr.	4,871,463 A	10/1989	Taylor et al.
4,161,178 A	7/1979	Genese	4,898,209 A	2/1990	Zdeb
4,187,848 A	2/1980	Taylor	4,909,290 A	3/1990	Coccia
D254,444 S	3/1980	Levine	4,919,596 A	4/1990	Slate et al.
4,203,067 A	5/1980	Bollongino et al.	4,927,423 A	5/1990	Malmborg
4,203,443 A	5/1980	Genese	4,931,040 A	6/1990	Haber et al.
4,210,173 A	7/1980	Choksi et al.	4,932,944 A	6/1990	Jagger et al.
D257,286 S	10/1980	Folkman	4,967,797 A	11/1990	Manska
4,253,501 A	3/1981	Ogle	D314,050 S	1/1991	Sone
4,262,671 A	4/1981	Kersten	D314,622 S	2/1991	Andersson et al.
4,296,786 A	10/1981	Brignola	4,997,430 A	3/1991	Van Der Heiden et al.
4,303,067 A	12/1981	Connolly et al.	5,006,114 A	4/1991	Rogers et al.
4,312,349 A	1/1982	Cohen	5,035,686 A	7/1991	Crittenden et al.
4,314,586 A	2/1982	Folkman	5,041,105 A	8/1991	D'Alo et al.
4,328,802 A	5/1982	Curley et al.	5,045,066 A	9/1991	Scheuble et al.
4,335,717 A	6/1982	Bujan et al.	5,049,129 A	9/1991	Zdeb et al.
D267,199 S	12/1982	Koenig	5,053,015 A	10/1991	Gross
4,364,387 A	12/1982	Larkin	5,061,248 A	10/1991	Sacco
4,376,634 A	3/1983	Prior et al.	5,088,996 A	2/1992	Kopfer et al.
D268,871 S	5/1983	Benham et al.	5,096,575 A	3/1992	Cosack
4,392,850 A	7/1983	Elias et al.	5,104,387 A	4/1992	Pokorney et al.
D270,282 S	8/1983	Gross	5,113,904 A	5/1992	Aslanian
4,410,321 A	10/1983	Pearson et al.	5,122,124 A	6/1992	Novacek et al.
4,411,662 A	10/1983	Pearson	5,125,908 A	6/1992	Cohen
D271,421 S	11/1983	Fetterman	5,125,915 A	6/1992	Berry et al.
4,434,823 A	3/1984	Hudspith	D328,788 S	8/1992	Sagae et al.
4,465,471 A	8/1984	Harris et al.	D331,281 S	11/1992	Levine
4,475,915 A	10/1984	Sloane	5,171,230 A	12/1992	Eland et al.
4,493,348 A	1/1985	Lemmons	5,181,508 A	1/1993	Poole, Jr.
4,505,709 A	3/1985	Froning et al.	5,201,705 A	4/1993	Berglund et al.
4,507,113 A	3/1985	Dunlap	5,201,717 A	4/1993	Wyatt et al.
D280,018 S	8/1985	Scott	5,203,771 A	4/1993	Melker et al.
4,532,969 A	8/1985	Kwaan	5,203,775 A	4/1993	Frank et al.
4,534,758 A	8/1985	Akers et al.	5,211,638 A	5/1993	Dudar et al.
4,561,445 A *	12/1985	Berke A61B 5/296 600/372	D337,828 S	7/1993	Gordon
4,564,054 A	1/1986	Gustavsson	5,232,029 A	8/1993	Knox et al.
4,573,993 A	3/1986	Hoag et al.	5,232,109 A	8/1993	Tirrell et al.
4,576,211 A	3/1986	Valentini et al.	5,242,432 A	9/1993	Defrank
4,581,014 A	4/1986	Millerd et al.	5,247,972 A	9/1993	Tetreault
4,585,446 A	4/1986	Kempf	D341,420 S	11/1993	Conn
4,588,396 A	5/1986	Stroebel et al.	5,269,768 A	12/1993	Cheung
4,588,403 A	5/1986	Weiss et al.	5,270,219 A	12/1993	Decastro et al.
D284,603 S	7/1986	Loignon	5,279,576 A	1/1994	Loo et al.
4,604,093 A	8/1986	Brown et al.	5,288,290 A	2/1994	Brody
4,607,671 A	8/1986	Aalto et al.	5,300,034 A	4/1994	Behnke et al.
4,614,437 A	9/1986	Buehler	5,301,685 A	4/1994	Guirguis
4,638,975 A	1/1987	Iuchi et al.	5,304,163 A	4/1994	Bonnici et al.
4,639,019 A	1/1987	Mittleman	5,304,165 A	4/1994	Haber et al.
4,667,927 A	5/1987	Oscarsson	5,308,483 A	5/1994	Sklar et al.
4,675,020 A	6/1987	Mcphee	5,312,377 A	5/1994	Dalton
			5,328,474 A	7/1994	Raines
			D349,648 S	8/1994	Tirrell et al.
			5,334,163 A	8/1994	Sinnett
			5,334,179 A	8/1994	Poli et al.
			5,342,346 A	8/1994	Honda et al.

(56)

References Cited

U.S. PATENT DOCUMENTS

5,344,417 A	9/1994	Wadsworth, Jr.	5,766,211 A	6/1998	Wood et al.
5,348,544 A	9/1994	Sweeney et al.	5,772,630 A	6/1998	Ljungquist
5,348,548 A	9/1994	Meyer et al.	5,772,652 A	6/1998	Zielinski
5,350,372 A	9/1994	Ikeda et al.	RE35,841 E	7/1998	Frank et al.
5,364,386 A	11/1994	Fukuoka et al.	5,776,116 A	7/1998	Lopez et al.
5,364,387 A	11/1994	Sweeney	5,782,872 A	7/1998	Muller
5,374,264 A	12/1994	Wadsworth, Jr.	5,806,831 A	9/1998	Paradis
5,385,547 A	1/1995	Wong et al.	5,810,792 A	9/1998	Fangrow et al.
5,397,303 A	3/1995	Sancoff et al.	5,814,020 A	9/1998	Gross
D357,733 S	4/1995	Matkovich	D399,558 S *	10/1998	Guala D24/112
5,429,614 A	7/1995	Fowles et al.	D399,559 S	10/1998	Molina
5,433,330 A	7/1995	Yatsko et al.	5,817,082 A	10/1998	Niedospial et al.
5,445,630 A	8/1995	Richmond	5,820,621 A	10/1998	Yale et al.
5,445,631 A	8/1995	Uchida	5,827,262 A	10/1998	Neftel et al.
D362,718 S	9/1995	Deily et al.	5,832,971 A	11/1998	Yale et al.
5,451,374 A	9/1995	Molina	5,833,213 A	11/1998	Ryan
5,454,805 A	10/1995	Brony	5,834,744 A	11/1998	Risman
5,464,111 A	11/1995	Vacek et al.	5,839,715 A	11/1998	Leinsing
5,464,123 A	11/1995	Scarrow	D403,398 S *	12/1998	Guala D24/112
5,466,219 A	11/1995	Lynn et al.	5,853,406 A	12/1998	Masuda et al.
5,466,220 A	11/1995	Brenneman	D405,522 S	2/1999	Hoenig et al.
5,470,327 A	11/1995	Helgren et al.	5,868,710 A	2/1999	Battiato et al.
5,471,994 A	12/1995	Guirguis	5,871,110 A	2/1999	Grimard et al.
5,472,022 A	12/1995	Michel et al.	5,873,872 A	2/1999	Thibault et al.
5,478,337 A	12/1995	Okamoto et al.	5,879,337 A	3/1999	Kuracina et al.
5,482,446 A	1/1996	Williamson et al.	5,879,345 A	3/1999	Aneas
5,492,147 A	2/1996	Challender et al.	5,887,633 A	3/1999	Yale et al.
5,496,274 A	3/1996	Graves et al.	5,890,610 A	4/1999	Jansen et al.
D369,406 S	4/1996	Niedospial et al.	5,891,129 A	4/1999	Daubert et al.
5,505,714 A	4/1996	Dassa et al.	5,893,397 A	4/1999	Peterson et al.
5,509,433 A	4/1996	Paradis	5,897,526 A	4/1999	Vaillancourt
5,515,871 A	5/1996	Bittner et al.	5,899,468 A	5/1999	Apps et al.
5,520,659 A	5/1996	Hedges	5,902,280 A	5/1999	Powles et al.
5,526,853 A	6/1996	Mcphee et al.	5,902,298 A	5/1999	Niedospial et al.
5,527,306 A	6/1996	Haining	D410,740 S	6/1999	Molina
5,531,695 A	7/1996	Swisher	5,911,710 A	6/1999	Barry et al.
5,547,471 A	8/1996	Thompson et al.	5,919,182 A	7/1999	Avallone
5,549,577 A	8/1996	Siegel et al.	5,921,419 A	7/1999	Niedospial et al.
5,554,128 A	9/1996	Hedges	5,924,584 A	7/1999	Hellstrom et al.
5,562,686 A	10/1996	Sauer et al.	5,925,029 A	7/1999	Jansen et al.
5,562,696 A	10/1996	Nobles et al.	5,935,112 A	8/1999	Stevens et al.
5,566,729 A	10/1996	Grabenkort et al.	5,941,848 A	8/1999	Nishimoto et al.
5,569,191 A	10/1996	Meyer	5,941,850 A	8/1999	Shah et al.
5,573,281 A	11/1996	Keller	5,944,700 A	8/1999	Nguyen et al.
5,578,015 A	11/1996	Robb	D414,562 S	9/1999	Tajima
5,583,052 A	12/1996	Portnoff et al.	5,954,104 A	9/1999	Daubert et al.
5,584,819 A	12/1996	Kopfer	5,968,022 A	10/1999	Saito
5,591,143 A	1/1997	Trombley et al.	5,971,181 A	10/1999	Niedospial et al.
5,603,706 A	2/1997	Wyatt et al.	5,971,965 A	10/1999	Mayer
5,607,439 A	3/1997	Yoon	D416,086 S	11/1999	Parris et al.
5,611,576 A	3/1997	Guala	5,989,237 A	11/1999	Fowles et al.
5,616,203 A	4/1997	Stevens	D417,733 S	12/1999	Howell et al.
5,636,660 A	6/1997	Pfleiderer et al.	6,003,566 A	12/1999	Thibault et al.
5,637,101 A	6/1997	Shillington	6,004,278 A	12/1999	Botich et al.
5,641,010 A	6/1997	Maier	6,019,750 A	2/2000	Fowles et al.
5,645,538 A	7/1997	Richmond	6,022,339 A	2/2000	Fowles et al.
5,647,845 A	7/1997	Haber et al.	6,036,171 A	3/2000	Weinheimer et al.
5,651,776 A	7/1997	Appling et al.	6,039,093 A	3/2000	Mrotzek et al.
5,653,686 A	8/1997	Coulter et al.	6,039,302 A	3/2000	Cote et al.
5,658,133 A	8/1997	Anderson et al.	D422,357 S	4/2000	Niedospial et al.
5,672,160 A	9/1997	Oesterlind et al.	6,053,899 A	4/2000	Slanda et al.
5,674,195 A	10/1997	Truthan	6,063,068 A	5/2000	Fowles et al.
5,676,346 A	10/1997	Leinsing	D427,308 S	6/2000	Zinger
5,685,845 A	11/1997	Grimard	D427,309 S	6/2000	Molina
D388,172 S	12/1997	Cipes	6,070,623 A	6/2000	Aneas
5,699,821 A	12/1997	Paradis	6,071,270 A	6/2000	Fowles et al.
5,702,019 A	12/1997	Grimard	6,080,132 A	6/2000	Cole et al.
5,718,346 A	2/1998	Weiler	D428,141 S	7/2000	Brotspies et al.
5,728,087 A	3/1998	Niedospial	6,086,762 A	7/2000	Guala
D393,722 S	4/1998	Fangrow et al.	6,089,541 A	7/2000	Weinheimer et al.
5,738,144 A	4/1998	Rogers	6,090,091 A	7/2000	Fowles et al.
5,743,312 A	4/1998	Pfeifer et al.	6,090,093 A	7/2000	Thibault et al.
5,746,733 A	5/1998	Capaccio et al.	6,092,692 A	7/2000	Riskin
5,752,942 A	5/1998	Doyle et al.	D430,291 S	8/2000	Jansen et al.
5,755,696 A	5/1998	Caizza	6,099,511 A	8/2000	Devos et al.
			6,113,068 A	9/2000	Ryan
			6,113,583 A	9/2000	Fowles et al.
			6,117,114 A	9/2000	Paradis
			D431,864 S	10/2000	Jansen

(56)

References Cited

U.S. PATENT DOCUMENTS

6,139,534	A	10/2000	Niedospial et al.	6,632,201	B1	10/2003	Mathias et al.
6,142,446	A	11/2000	Leinsing	6,638,244	B1	10/2003	Reynolds
6,146,362	A	11/2000	Turnbull et al.	D482,121	S	11/2003	Harding et al.
6,149,623	A	11/2000	Reynolds	D482,447	S	11/2003	Harding et al.
6,156,025	A	12/2000	Niedospial et al.	6,651,956	B2	11/2003	Miller
6,159,192	A	12/2000	Fowles et al.	6,652,509	B1	11/2003	Helgren et al.
6,162,199	A	12/2000	Geringer	D483,487	S	12/2003	Harding et al.
6,168,037	B1	1/2001	Grimard	D483,869	S	12/2003	Tran et al.
6,171,287	B1	1/2001	Lynn et al.	6,656,433	B2	12/2003	Sasso
6,171,293	B1	1/2001	Rowley et al.	6,666,852	B2	12/2003	Niedospial
6,173,852	B1	1/2001	Browne	6,681,810	B2	1/2004	Weston
6,173,868	B1	1/2001	Dejonge	6,681,946	B1	1/2004	Jansen et al.
6,174,304	B1	1/2001	Weston	6,682,509	B2	1/2004	Lopez
6,179,822	B1	1/2001	Niedospial	6,692,478	B1	2/2004	Paradis
6,179,823	B1	1/2001	Niedospial, Jr.	6,692,829	B2	2/2004	Stubler et al.
6,186,997	B1	2/2001	Gabbard et al.	6,695,829	B2	2/2004	Hellstrom et al.
6,206,861	B1	3/2001	Mayer	6,699,229	B2	3/2004	Zinger et al.
6,221,041	B1	4/2001	Russo	6,699,232	B2	3/2004	Hart et al.
6,221,054	B1	4/2001	Martin et al.	6,706,022	B1	3/2004	Leinsing et al.
6,221,065	B1	4/2001	Davis	6,706,031	B2	3/2004	Manera
6,238,372	B1	5/2001	Zinger et al.	6,715,520	B2	4/2004	Andreasson et al.
6,245,044	B1	6/2001	Daw et al.	6,729,370	B2	5/2004	Norton et al.
D445,501	S	7/2001	Niedospial	6,736,798	B2	5/2004	Ohkubo et al.
D445,895	S	7/2001	Svendson	6,745,998	B2	6/2004	Doyle
6,253,804	B1	7/2001	Safabash	6,746,438	B1	6/2004	Arnisolle
6,258,078	B1	7/2001	Thilly	6,752,180	B2	6/2004	Delay
6,280,430	B1	8/2001	Neffel et al.	D495,416	S	8/2004	Dimeo et al.
6,290,688	B1	9/2001	Lopez et al.	D496,457	S	9/2004	Prais et al.
6,296,621	B1	10/2001	Masuda et al.	6,802,490	B2	10/2004	Leinsing et al.
6,299,131	B1	10/2001	Ryan	6,832,994	B2	12/2004	Niedospial et al.
D453,221	S	1/2002	Haytman et al.	6,852,103	B2	2/2005	Fowles et al.
6,343,629	B1	2/2002	Wessman et al.	6,875,203	B1	4/2005	Fowles et al.
6,348,044	B1	2/2002	Coletti et al.	6,875,205	B2	4/2005	Leinsing
6,358,236	B1	3/2002	Defoggi et al.	6,878,131	B2	4/2005	Novacek et al.
6,364,866	B1	4/2002	Furr et al.	6,884,253	B1	4/2005	Mcfarlane
6,378,576	B2	4/2002	Thibault et al.	6,890,328	B2	5/2005	Fowles et al.
6,378,714	B1	4/2002	Jansen et al.	D506,256	S	6/2005	Miyoshi et al.
6,379,340	B1	4/2002	Zinger et al.	6,901,975	B2	6/2005	Aramata et al.
D457,954	S	5/2002	Wallace et al.	6,945,417	B2	9/2005	Jansen et al.
6,382,442	B1	5/2002	Thibault et al.	6,948,522	B2	9/2005	Newbrough et al.
6,386,397	B2	5/2002	Brotspies et al.	6,949,086	B2	9/2005	Ferguson et al.
6,408,897	B1	6/2002	Laurent et al.	6,951,613	B2	10/2005	Reif et al.
6,409,708	B1	6/2002	Wessman	6,953,450	B2	10/2005	Baldwin et al.
6,419,696	B1	7/2002	Ortiz et al.	6,957,745	B2	10/2005	Thibault et al.
6,440,107	B1	8/2002	Trombley, III et al.	6,960,164	B2	11/2005	O'Heeron
6,453,949	B1	9/2002	Chau	6,964,684	B2	11/2005	Ortiz et al.
6,453,956	B2	9/2002	Safabash	6,972,002	B2	12/2005	Thorne
6,474,375	B2	11/2002	Spero et al.	6,979,318	B1	12/2005	Mcdonald et al.
6,478,788	B1	11/2002	Aneas	RE38,996	E	2/2006	Crawford et al.
D468,015	S	12/2002	Horppu	6,994,315	B2	2/2006	Ryan et al.
6,499,617	B1	12/2002	Niedospial et al.	6,997,916	B2	2/2006	Simas et al.
6,503,240	B1	1/2003	Niedospial et al.	6,997,917	B2	2/2006	Niedospial et al.
6,503,244	B2	1/2003	Hayman	7,024,968	B2	4/2006	Raudabough et al.
6,520,932	B2	2/2003	Taylor	7,070,589	B2	7/2006	Lolachi et al.
6,524,278	B1	2/2003	Campbell et al.	7,074,216	B2	7/2006	Fowles et al.
6,524,295	B2	2/2003	Daubert et al.	7,083,600	B2	8/2006	Meloul
D472,316	S	3/2003	Douglas et al.	7,086,431	B2	8/2006	D'Antonio et al.
6,530,903	B2	3/2003	Wang et al.	7,097,637	B2	8/2006	Triplett et al.
6,537,263	B1	3/2003	Aneas	7,100,890	B2	9/2006	Cote et al.
D472,630	S	4/2003	Douglas et al.	7,140,401	B2	11/2006	Wilcox et al.
6,544,246	B1	4/2003	Niedospial	7,150,735	B2	12/2006	Hickle
6,551,299	B2	4/2003	Miyoshi et al.	7,192,423	B2	3/2007	Wong
6,558,365	B2	5/2003	Zinger et al.	7,195,623	B2	3/2007	Burroughs et al.
6,569,196	B1	5/2003	Vesely	D546,450	S *	7/2007	Wolf D24/108
6,571,837	B2	6/2003	Jansen et al.	7,241,285	B1	7/2007	Dikeman
6,572,591	B2	6/2003	Mayer	7,294,122	B2	11/2007	Kubo et al.
6,575,955	B2	6/2003	Azzolini	7,306,199	B2	12/2007	Leinsing et al.
6,581,593	B1	6/2003	Rubin et al.	D560,815	S	1/2008	Tajima
6,581,648	B1	6/2003	Zolentoff et al.	D561,348	S	2/2008	Zinger et al.
6,582,415	B1	6/2003	Fowles et al.	7,326,188	B1	2/2008	Russell et al.
D476,731	S	7/2003	Cise et al.	7,326,194	B2	2/2008	Zinger et al.
6,591,876	B2	7/2003	Safabash	7,335,213	B1	2/2008	Hyde et al.
6,599,273	B1	7/2003	Lopez	7,350,764	B2	4/2008	Raybuck
6,601,721	B2	8/2003	Jansen et al.	7,354,422	B2	4/2008	Riesenberger et al.
6,626,309	B1	9/2003	Jansen et al.	7,354,427	B2	4/2008	Fangrow
				D573,250	S	7/2008	MacRae et al.
				D575,314	S	8/2008	Hind
				7,425,209	B2	9/2008	Fowles et al.
				7,435,246	B2	10/2008	Zihlmann

(56)

References Cited

U.S. PATENT DOCUMENTS

D580,558 S	11/2008	Shigesada et al.	8,029,472 B2	10/2011	Leinsing et al.
D581,529 S	11/2008	Moehle et al.	8,038,123 B2	10/2011	Ruschke et al.
7,452,348 B2	11/2008	Hasegawa	8,066,688 B2	11/2011	Zinger et al.
7,470,257 B2	12/2008	Norton et al.	8,070,739 B2	12/2011	Zinger et al.
7,470,265 B2	12/2008	Brugger et al.	8,075,550 B2	12/2011	Nord et al.
7,472,932 B2	1/2009	Weber et al.	8,096,525 B2	1/2012	Ryan
7,488,297 B2	2/2009	Flaherty	8,105,314 B2	1/2012	Fangrow, Jr.
7,491,197 B2	2/2009	Jansen et al.	D654,166 S	2/2012	Lair
7,497,848 B2	3/2009	Leinsing et al.	D655,017 S	2/2012	Mosler et al.
7,500,961 B2	3/2009	Nemoto	8,122,923 B2	2/2012	Kraus et al.
7,523,967 B2	4/2009	Steppe	8,123,736 B2	2/2012	Kraushaar et al.
7,530,546 B2	5/2009	Ryan et al.	D655,071 S	3/2012	Davila
D595,420 S	6/2009	Suzuki et al.	D657,461 S	4/2012	Schembre et al.
D595,421 S	6/2009	Suzuki et al.	8,152,779 B2	4/2012	Cabiri
7,540,863 B2	6/2009	Haindl	8,157,784 B2	4/2012	Rogers
7,540,865 B2	6/2009	Griffin et al.	8,167,863 B2	5/2012	Yow
7,544,191 B2	6/2009	Peluso et al.	8,172,824 B2	5/2012	Pfeifer et al.
D595,862 S	7/2009	Suzuki et al.	8,177,768 B2	5/2012	Leinsing
D595,863 S	7/2009	Suzuki et al.	8,182,452 B2	5/2012	Mansour et al.
7,569,062 B1	8/2009	Kuehn et al.	8,187,248 B2	5/2012	Zihlmann
D604,837 S	11/2009	Crawford et al.	8,196,614 B2	6/2012	Kriheli
7,611,487 B2	11/2009	Woehr et al.	8,197,459 B2	6/2012	Jansen et al.
7,611,502 B2	11/2009	Daly	8,211,069 B2	7/2012	Fangrow, Jr.
7,615,041 B2	11/2009	Sullivan et al.	8,225,959 B2	7/2012	Lambrecht
7,628,779 B2	12/2009	Aneas	8,241,268 B2	8/2012	Whitley
7,632,261 B2	12/2009	Zinger et al.	8,262,628 B2	9/2012	Fangrow, Jr.
D608,900 S	1/2010	Giraud et al.	8,262,641 B2	9/2012	Vedrine et al.
D609,804 S	2/2010	Uchida et al.	8,267,127 B2	9/2012	Kriheli
7,654,995 B2	2/2010	Warren et al.	D669,980 S	10/2012	Lev et al.
7,670,326 B2	3/2010	Shemesh	8,287,513 B2	10/2012	Ellstrom et al.
7,695,445 B2	4/2010	Yuki	D671,654 S	11/2012	Akamatsu et al.
7,703,483 B2	4/2010	Hartman et al.	8,317,741 B2	11/2012	Kraushaar
7,704,229 B2	4/2010	Moberg et al.	8,328,784 B2	12/2012	Jensen et al.
7,704,236 B2	4/2010	Denolly	D673,673 S	1/2013	Wang
D616,090 S	5/2010	Kawamura	D674,084 S	1/2013	Linnenschmidt
7,713,247 B2	5/2010	Lopez	D674,088 S	1/2013	Lev et al.
7,717,886 B2	5/2010	Lopez	8,348,898 B2	1/2013	Cabiri
7,722,090 B2	5/2010	Burton et al.	D681,230 S	4/2013	Mosler et al.
D616,984 S	6/2010	Gilboa	8,418,690 B2	4/2013	Power et al.
7,731,678 B2	6/2010	Tennican et al.	8,454,573 B2	6/2013	Wyatt et al.
7,743,799 B2	6/2010	Mosier et al.	8,469,939 B2	6/2013	Fangrow, Jr.
7,744,581 B2	6/2010	Wallen et al.	8,475,404 B2	7/2013	Foshee et al.
7,757,901 B2	7/2010	Welp	8,480,645 B1	7/2013	Choudhury et al.
7,758,082 B2	7/2010	Weigel et al.	8,480,646 B2	7/2013	Nord et al.
7,758,560 B2	7/2010	Connell et al.	8,506,548 B2	8/2013	Okiyama
7,762,524 B2	7/2010	Cawthon et al.	8,511,352 B2	8/2013	Kraus et al.
7,766,304 B2	8/2010	Phillips	8,512,309 B2	8/2013	Shemesh et al.
7,771,383 B2	8/2010	Truitt et al.	D689,605 S	9/2013	Bellenoit
D624,641 S	9/2010	Boclet	D690,009 S	9/2013	Schembre et al.
7,799,009 B2	9/2010	Niedospial et al.	D690,418 S	9/2013	Rosenquist
7,803,140 B2	9/2010	Fangrow, Jr.	8,523,837 B2	9/2013	Wiggins et al.
D627,216 S	11/2010	Fulginiti	D691,264 S	10/2013	Dallemagne et al.
D630,732 S	1/2011	Lev et al.	8,545,476 B2	10/2013	Ariagno et al.
7,862,537 B2	1/2011	Zinger et al.	8,551,067 B2	10/2013	Zinger et al.
7,867,215 B2	1/2011	Akerlund et al.	8,556,879 B2	10/2013	Okiyama
7,879,018 B2	2/2011	Zinger et al.	8,562,582 B2	10/2013	Tuckwell et al.
7,883,499 B2	2/2011	Fangrow	8,608,723 B2	12/2013	Lev et al.
7,887,583 B2	2/2011	Macoviak	8,628,508 B2	1/2014	Weitzel et al.
7,895,216 B2	2/2011	Longshaw et al.	8,636,689 B2	1/2014	Halili et al.
D634,007 S *	3/2011	Zinger D24/129	D703,812 S	4/2014	Cederschiold et al.
7,896,849 B2	3/2011	Delay	8,684,992 B2	4/2014	Sullivan et al.
7,900,659 B2	3/2011	Whitley et al.	8,684,994 B2	4/2014	Lev et al.
7,914,499 B2	3/2011	Gonnelli et al.	8,752,598 B2	6/2014	Denenburg et al.
D637,713 S	5/2011	Nord et al.	D714,935 S	10/2014	Nishioka et al.
7,963,954 B2	6/2011	Kavazov	D717,406 S	11/2014	Stanley et al.
D641,080 S	7/2011	Zinger et al.	D717,948 S	11/2014	Strong et al.
7,985,216 B2	7/2011	Daily et al.	D719,650 S	12/2014	Arinobe et al.
D644,104 S	8/2011	Maeda et al.	D720,067 S	12/2014	Rosenquist
7,993,328 B2	8/2011	Whitley	D720,451 S	12/2014	Denenburg et al.
8,007,461 B2	8/2011	Huo et al.	D720,452 S	12/2014	Jordan
8,012,132 B2	9/2011	Lum et al.	8,900,212 B2	12/2014	Kubo
8,016,809 B2	9/2011	Zinger et al.	8,905,994 B1	12/2014	Lev et al.
8,021,325 B2	9/2011	Zinger et al.	8,915,882 B2	12/2014	Cabiri
8,025,653 B2	9/2011	Capitaine et al.	D720,850 S	1/2015	Hsia et al.
8,025,683 B2	9/2011	Morrison	8,986,370 B2	3/2015	Annest
			9,011,522 B2	4/2015	Annest
			D732,660 S	6/2015	Ohashi
			D732,664 S	6/2015	Woehr et al.
			D733,291 S	6/2015	Wang

(56)

References Cited

U.S. PATENT DOCUMENTS

D733,292 S	6/2015	Rogers	
D733,293 S	6/2015	Rogers	
9,072,827 B2	7/2015	Cabiri	
D738,494 S	9/2015	Kashmirian	
D741,457 S	10/2015	Guest	
9,149,575 B2	10/2015	Cabiri	
D750,235 S	2/2016	Maurice	
9,254,242 B2	2/2016	Mueller et al.	
D757,933 S	5/2016	Lev et al.	
9,393,365 B2	7/2016	Cabiri	
D765,837 S *	9/2016	Lev	D24/129
D767,124 S *	9/2016	Lev	D24/129
9,486,391 B2	11/2016	Shemesh	
9,492,610 B2	11/2016	Cabiri	
9,511,190 B2	12/2016	Cabiri	
9,522,234 B2	12/2016	Cabiri	
D794,183 S	8/2017	Lev et al.	
9,763,855 B2	9/2017	Fangrow	
D833,599 S	11/2018	Nilsson et al.	
D836,324 S *	12/2018	Michalski	D3/28
10,206,854 B2	2/2019	Wu et al.	
D849,936 S	5/2019	Allard	
D851,240 S *	6/2019	Baid	A61M 5/165 D24/112
10,413,662 B2	9/2019	Yeh et al.	
D881,389 S	4/2020	Wang et al.	
D881,390 S	4/2020	Wang et al.	
10,772,798 B2 *	9/2020	Lev	A61J 1/10
D903,836 S *	12/2020	Pak	D23/262
D923,782 S *	6/2021	Lev	D24/129
D923,812 S *	6/2021	Ben Shalom	D24/220
2001/0000347 A1	4/2001	Hellstrom et al.	
2001/0025671 A1	10/2001	Safabash	
2001/0029360 A1	10/2001	Miyoshi et al.	
2001/0047150 A1	11/2001	Chobotov	
2001/0051793 A1	12/2001	Weston	
2002/0017328 A1	2/2002	Loo	
2002/0029080 A1	3/2002	Mortier et al.	
2002/0055711 A1	5/2002	Lavi et al.	
2002/0065488 A1	5/2002	Suzuki et al.	
2002/0066715 A1	6/2002	Niedospial	
2002/0087118 A1	7/2002	Reynolds et al.	
2002/0087141 A1	7/2002	Zinger et al.	
2002/0087144 A1	7/2002	Zinger et al.	
2002/0104584 A1	8/2002	Spero et al.	
2002/0115980 A1	8/2002	Niedospial et al.	
2002/0121496 A1	9/2002	Thiebault et al.	
2002/0123736 A1	9/2002	Fowles et al.	
2002/0123737 A1	9/2002	Hart et al.	
2002/0127150 A1	9/2002	Sasso	
2002/0128628 A1	9/2002	Fathallah	
2002/0138045 A1	9/2002	Moen	
2002/0173752 A1	11/2002	Polzin	
2002/0193777 A1	12/2002	Aneas	
2003/0028156 A1	2/2003	Juliar	
2003/0036725 A1	2/2003	Lavi et al.	
2003/0068354 A1	4/2003	Reif et al.	
2003/0069550 A1	4/2003	Sharp	
2003/0073971 A1	4/2003	Saker	
2003/0083742 A1	5/2003	Spence et al.	
2003/0100866 A1	5/2003	Reynolds	
2003/0109846 A1	6/2003	Zinger et al.	
2003/0120209 A1	6/2003	Jensen et al.	
2003/0135159 A1	7/2003	Daily et al.	
2003/0153895 A1	8/2003	Leinsing	
2003/0187420 A1	10/2003	Akerlund et al.	
2003/0191445 A1	10/2003	Wallen et al.	
2003/0195479 A1	10/2003	Kuracina et al.	
2003/0199827 A1	10/2003	Thorne	
2003/0199846 A1	10/2003	Fowles et al.	
2003/0199847 A1	10/2003	Akerlund et al.	
2003/0205843 A1	11/2003	Adams	
2003/0236543 A1	12/2003	Brenneman et al.	
2004/0010207 A1	1/2004	Flaherty et al.	
2004/0024354 A1	2/2004	Reynolds	
2004/0039365 A1			
2004/0044327 A1			
2004/0044406 A1			
2004/0073189 A1			
2004/0143218 A1			
2004/0143226 A1			
2004/0153047 A1			
2004/0158172 A1			
2004/0162515 A1			
2004/0162540 A1			
2004/0167472 A1			
2004/0167620 A1			
2004/0181192 A1			
2004/0186424 A1			
2004/0199139 A1			
2004/0204699 A1			
2004/0217315 A1			
2004/0225274 A1			
2004/0236305 A1			
2004/0236419 A1			
2004/0249341 A1			
2004/0255952 A1			
2005/0010287 A1			
2005/0015070 A1			
2005/0016626 A1			
2005/0049553 A1			
2005/0055008 A1			
2005/0070999 A1			
2005/0075727 A1			
2005/0082828 A1			
2005/0124964 A1			
2005/0137523 A1			
2005/0137566 A1			
2005/0137702 A1			
2005/0148994 A1			
2005/0159706 A1			
2005/0159724 A1			
2005/0182383 A1			
2005/0209554 A1			
2005/0261637 A1			
2005/0277896 A1			
2006/0030832 A1			
2006/0049209 A1			
2006/0058741 A1			
2006/0074484 A1			
2006/0079834 A1			
2006/0089594 A1			
2006/0089603 A1			
2006/0095015 A1			
2006/0106360 A1			
2006/0135948 A1			
2006/0155257 A1			
2006/0161192 A1			
2006/0169348 A1			
2006/0173410 A1			
2006/0178646 A1			
2006/0195029 A1			
2006/0212004 A1			
2006/0224105 A1			
2006/0253084 A1			
2006/0259004 A1			
2006/0259135 A1			
2007/0016381 A1			
2007/0024995 A1			
2007/0060904 A1			
2007/0078428 A1			
2007/0079894 A1			
2007/0083164 A1			
2007/0088252 A1			
2007/0088293 A1			
2007/0088313 A1			
2007/0095856 A1			
2007/0106218 A1			
2007/0106244 A1			
2007/0112324 A1			
2007/0156112 A1			
2007/0167904 A1			
2007/0167912 A1			
2007/0191760 A1			
2/2004		Aramata et al.	
3/2004		Hasegawa	
3/2004		Woolfson et al.	
4/2004		Wyatt et al.	
7/2004		Das	
7/2004		Marsden	
8/2004		Blank et al.	
8/2004		Hancock	
8/2004		Chornenky et al.	
8/2004		Walenciak et al.	
8/2004		Howell et al.	
8/2004		Ortiz et al.	
9/2004		Cuppy	
9/2004		Hjertman	
10/2004		Fowles et al.	
10/2004		Hanly et al.	
11/2004		Doyle	
11/2004		Jansen et al.	
11/2004		Jansen et al.	
11/2004		Milo	
12/2004		Newbrough et al.	
12/2004		Carlsen et al.	
1/2005		Macoviak et al.	
1/2005		Delnevo et al.	
1/2005		Wilcox et al.	
3/2005		Triplett et al.	
3/2005		Paradis et al.	
3/2005		Spence	
4/2005		Wheatley	
4/2005		Wicks et al.	
6/2005		Niedospial et al.	
6/2005		Wyatt et al.	
6/2005		Fowles et al.	
6/2005		Haug et al.	
7/2005		Leinsing	
7/2005		Wilkinson et al.	
7/2005		Enerson	
8/2005		Wallen	
9/2005		Landau	
11/2005		Miller	
12/2005		Messerli et al.	
2/2006		Niedospial et al.	
3/2006		Baker	
3/2006		Gallagher	
4/2006		Huber	
4/2006		Tennican et al.	
4/2006		Landau	
4/2006		Truitt et al.	
5/2006		Hobbs et al.	
5/2006		Wong	
6/2006		Varma	
7/2006		Reynolds	
7/2006		Young	
8/2006		Yigal	
8/2006		Moberg et al.	
8/2006		Harris et al.	
8/2006		Shults et al.	
9/2006		Atil	
10/2006		Thorne et al.	
11/2006		Nordgren	
11/2006		Connell et al.	
11/2006		Navia et al.	
1/2007		Kamath et al.	
2/2007		Hayashi	
3/2007		Vedrine et al.	
4/2007		Reynolds et al.	
4/2007		Kraus et al.	
4/2007		Barrelle et al.	
4/2007		Pestotnik et al.	
4/2007		Fangrow	
4/2007		Zinger et al.	
5/2007		Vogel et al.	
5/2007		Yodfat et al.	
5/2007		Mosler et al.	
5/2007		Hamedi-Sangsari	
7/2007		Walsh	
7/2007		Zinger et al.	
7/2007		Causey et al.	
8/2007		Iguchi et al.	

(56)

References Cited

U.S. PATENT DOCUMENTS

2007/0191764 A1	8/2007	Zihlmann	2010/0162548 A1	7/2010	Leidig
2007/0191767 A1	8/2007	Hennessy et al.	2010/0168664 A1	7/2010	Zinger et al.
2007/0203451 A1	8/2007	Murakami et al.	2010/0168712 A1	7/2010	Tuckwell et al.
2007/0219483 A1	9/2007	Kitani et al.	2010/0179506 A1	7/2010	Shemesh et al.
2007/0244447 A1	10/2007	Capitaine et al.	2010/0198148 A1	8/2010	Zinger et al.
2007/0244461 A1	10/2007	Fangrow	2010/0204670 A1	8/2010	Kraushaar et al.
2007/0244462 A1	10/2007	Fangrow	2010/0228220 A1	9/2010	Zinger et al.
2007/0244463 A1	10/2007	Warren et al.	2010/0241088 A1	9/2010	Ranalletta et al.
2007/0249995 A1	10/2007	Van Manen	2010/0262232 A1	10/2010	Annest
2007/0255202 A1	11/2007	Kitani et al.	2010/0274184 A1	10/2010	Chun
2007/0265574 A1	11/2007	Tennican et al.	2010/0274202 A1	10/2010	Hyde et al.
2007/0265581 A1	11/2007	Funamura et al.	2010/0286661 A1	11/2010	Raday et al.
2007/0270778 A9	11/2007	Zinger et al.	2010/0305548 A1	12/2010	Kraushaar
2007/0287953 A1	12/2007	Ziv et al.	2010/0312220 A1	12/2010	Kalitzki
2007/0299404 A1	12/2007	Katoh et al.	2011/0004143 A1	1/2011	Beiriger et al.
2008/0009789 A1	1/2008	Zinger et al.	2011/0004184 A1	1/2011	Proksch et al.
2008/0009822 A1	1/2008	Enerson	2011/0044850 A1	2/2011	Solomon et al.
2008/0015496 A1	1/2008	Hamedi-Sangsari	2011/0054440 A1	3/2011	Lewis
2008/0039935 A1	2/2008	Buch et al.	2011/0087164 A1	4/2011	Mosler et al.
2008/0077235 A1	3/2008	Kirson	2011/0125056 A1	5/2011	Merchant
2008/0125860 A1	5/2008	Webler et al.	2011/0144584 A1	6/2011	Wozencroft
2008/0135051 A1	6/2008	Lee	2011/0160655 A1	6/2011	Hanson et al.
2008/0167713 A1	7/2008	Bolling	2011/0160701 A1	6/2011	Wyatt et al.
2008/0172024 A1	7/2008	Yow	2011/0172636 A1	7/2011	Aasmul
2008/0188799 A1	8/2008	Mueller-Beckhaus et al.	2011/0175347 A1	7/2011	Okiyama
2008/0195049 A1	8/2008	Thalmann et al.	2011/0218511 A1	9/2011	Yokoyama
2008/0208138 A1	8/2008	Lim et al.	2011/0224640 A1	9/2011	Kuehn et al.
2008/0215015 A1	9/2008	Cindrich et al.	2011/0230856 A1	9/2011	Kyle et al.
2008/0249473 A1	10/2008	Rutti et al.	2011/0264037 A1	10/2011	Foshee et al.
2008/0249479 A1	10/2008	Zinger et al.	2011/0264069 A1	10/2011	Bochenko
2008/0249498 A1	10/2008	Fangrow	2011/0275988 A1	11/2011	Davis et al.
2008/0262465 A1*	10/2008	Zinger A61J 1/1487 604/411	2011/0276007 A1	11/2011	Denenburg
2008/0262609 A1	10/2008	Gross et al.	2011/0319827 A1	12/2011	Leinsing et al.
2008/0269687 A1	10/2008	Chong et al.	2012/0022344 A1	1/2012	Kube
2008/0275407 A1	11/2008	Scheurer	2012/0022469 A1	1/2012	Alpert
2008/0287905 A1	11/2008	Hiejima et al.	2012/0053555 A1	3/2012	Ariagno et al.
2008/0294100 A1	11/2008	De et al.	2012/0059332 A1	3/2012	Woehr et al.
2008/0306439 A1	12/2008	Nelson et al.	2012/0059346 A1	3/2012	Sheppard et al.
2008/0312634 A1	12/2008	Helmerson et al.	2012/0067429 A1	3/2012	Mosler et al.
2009/0012492 A1	1/2009	Zihlmann	2012/0071819 A1	3/2012	Brueggemann et al.
2009/0043253 A1	2/2009	Podaima	2012/0078214 A1	3/2012	Finke et al.
2009/0054834 A1	2/2009	Zinger et al.	2012/0123382 A1	5/2012	Kubo
2009/0054852 A1	2/2009	Takano et al.	2012/0184938 A1	7/2012	Lev et al.
2009/0054969 A1	2/2009	Salahieh et al.	2012/0215182 A1	8/2012	Mansour et al.
2009/0062767 A1	3/2009	Van et al.	2012/0220977 A1	8/2012	Yow
2009/0076360 A1	3/2009	Brister et al.	2012/0220978 A1	8/2012	Lev et al.
2009/0082750 A1	3/2009	Denenburg et al.	2012/0265163 A1	10/2012	Cheng et al.
2009/0139724 A1	6/2009	Gray et al.	2012/0271229 A1	10/2012	Lev et al.
2009/0143758 A1	6/2009	Okiyama	2012/0296307 A1	11/2012	Holt et al.
2009/0177177 A1	7/2009	Zinger et al.	2012/0310203 A1	12/2012	Khaled et al.
2009/0177178 A1	7/2009	Pedersen	2012/0323172 A1	12/2012	Lev et al.
2009/0187140 A1	7/2009	Racz	2012/0323187 A1	12/2012	Iwase et al.
2009/0216103 A1	8/2009	Brister et al.	2012/0323210 A1	12/2012	Lev et al.
2009/0216212 A1	8/2009	Fangrow, Jr.	2013/0046269 A1	2/2013	Lev et al.
2009/0257306 A1	10/2009	Coffeen et al.	2013/0053814 A1	2/2013	Mueller-Beckhaus et al.
2009/0267011 A1	10/2009	Hatton et al.	2013/0096493 A1	4/2013	Kubo et al.
2009/0299325 A1	12/2009	Vedrine et al.	2013/0110049 A1	5/2013	Cronenberg et al.
2009/0318946 A1	12/2009	Tamesada	2013/0144248 A1	6/2013	Putter et al.
2009/0326506 A1	12/2009	Hasegawa et al.	2013/0199669 A1	8/2013	Moy et al.
2010/0010443 A1	1/2010	Morgan et al.	2013/0226100 A1	8/2013	Lev
2010/0016811 A1	1/2010	Smith	2013/0231630 A1	9/2013	Kraus et al.
2010/0022985 A1	1/2010	Sullivan et al.	2013/0237904 A1	9/2013	Deneburg et al.
2010/0030181 A1	2/2010	Helle et al.	2013/0253448 A1	9/2013	Baron et al.
2010/0036319 A1	2/2010	Drake et al.	2013/0289530 A1	10/2013	Wyatt et al.
2010/0042147 A1	2/2010	Janovsky et al.	2013/0315026 A1	11/2013	Cheio De Oliveira et al.
2010/0049315 A1	2/2010	Kirson	2013/0317472 A1	11/2013	Finke
2010/0070027 A1	3/2010	Bonhoeffer et al.	2014/0020793 A1	1/2014	Denenburg et al.
2010/0076397 A1	3/2010	Reed et al.	2014/0096862 A1	4/2014	Aneas
2010/0087786 A1	4/2010	Zinger et al.	2014/0102552 A1	4/2014	Shemesh
2010/0137827 A1	6/2010	Warren et al.	2014/0150911 A1*	6/2014	Hanner A61M 5/1407 137/798
2010/0137831 A1	6/2010	Tsals	2014/0194854 A1	7/2014	Tsals
2010/0152658 A1	6/2010	Hanson et al.	2014/0221940 A1	8/2014	Clauson et al.
2010/0160889 A1	6/2010	Smith et al.	2014/0276215 A1	9/2014	Nelson et al.
2010/0161047 A1	6/2010	Cabiri	2014/0277052 A1	9/2014	Haselby et al.
			2014/0352845 A1	12/2014	Lev et al.
			2015/0082746 A1	3/2015	Ivosevic et al.
			2015/0088078 A1	3/2015	Lev et al.
			2015/0112297 A1	4/2015	Lev et al.

(56)

References Cited

U.S. PATENT DOCUMENTS

2015/0209230 A1 7/2015 Lev et al.
 2015/0250681 A1 9/2015 Lev et al.
 2015/0290390 A1 10/2015 Ring et al.
 2015/0297839 A1 10/2015 Sanders et al.
 2015/0297880 A1 10/2015 Ogawa et al.
 2015/0305770 A1 10/2015 Fill et al.
 2016/0081308 A1 3/2016 Cary et al.
 2016/0081878 A1 3/2016 Marks et al.
 2016/0088995 A1 3/2016 Ueda et al.
 2016/0166824 A1* 6/2016 Lev A61M 39/10
 604/411
 2016/0199569 A1 7/2016 Yevmenenko et al.
 2016/0228644 A1 8/2016 Cabiri
 2016/0287475 A1 10/2016 Yevmenenko et al.
 2016/0367439 A1 12/2016 Davis et al.
 2018/0008513 A1 1/2018 Iibuchi et al.
 2018/0161243 A1 6/2018 Ariagno et al.
 2018/0221572 A1 8/2018 Schlitt et al.
 2018/0303720 A1 10/2018 Kennard et al.
 2019/0083357 A1 3/2019 David et al.
 2019/0117514 A1 4/2019 Denenburg et al.
 2019/0133885 A1 5/2019 Wu et al.
 2019/0343725 A1 11/2019 Denenburg
 2020/0093692 A1* 3/2020 Lev A61J 1/2089
 2020/0276084 A1 9/2020 Denenburg
 2020/0282133 A1* 9/2020 Mason A61J 1/1406
 2020/0330326 A1* 10/2020 Merchant A61J 1/201
 2020/0376194 A1* 12/2020 Fabrikant A61J 1/2013

FOREIGN PATENT DOCUMENTS

CN 1747683 A 3/2006
 CN 1863566 A 11/2006
 CN 1950049 A 4/2007
 CN 101001661 A 7/2007
 CN 101687083 A 3/2010
 CN 201330626512 12/2013
 CN 106413799 A 2/2017
 CN 306375580 * 3/2021
 DE 1064693 B 9/1959
 DE 1913926 A1 9/1970
 DE 4122476 A1 1/1993
 DE 4314657 A1 11/1994
 DE 4408498 A1 5/1995
 DE 19504413 A1 8/1996
 DE 202004012714 U1 11/2004
 DE 102007046951 B3 2/2009
 DE 202009011019 U1 12/2010
 EM 001126270-0001 4/2009
 EM 001680703 3/2010
 EM 001680703-0002 8/2010
 EM 002446062-0002 8/2010
 EM 000627237-0001 10/2010
 EM 002446062 4/2014
 EM 006630893 7/2019
 EM 008039507-0004 * 1/2021
 EP 0192661 A1 9/1986
 EP 0195018 A1 9/1986
 EP 0258913 A2 3/1988
 EP 0416454 A2 3/1991
 EP 0426403 A1 5/1991
 EP 0282545 B1 2/1992
 EP 0518397 A1 12/1992
 EP 0521460 A1 1/1993
 EP 0582038 A2 2/1994
 EP 0598918 A1 6/1994
 EP 0637443 A1 2/1995
 EP 0737467 A1 10/1996
 EP 0761562 A1 3/1997
 EP 0765652 A1 4/1997
 EP 0765853 A1 4/1997
 EP 0806597 A1 11/1997
 EP 0814866 A1 1/1998
 EP 0829248 A2 3/1998

EP 0856331 A2 8/1998
 EP 0882441 A2 12/1998
 EP 0887085 A2 12/1998
 EP 0887885 A2 12/1998
 EP 0897708 A2 2/1999
 EP 0898951 A2 3/1999
 EP 0960616 A2 12/1999
 EP 1008337 A1 6/2000
 EP 1029526 A1 8/2000
 EP 1034809 A1 9/2000
 EP 1051988 A2 11/2000
 EP 1323403 A1 7/2003
 EP 1329210 A1 7/2003
 EP 1396250 A1 3/2004
 EP 1454609 A1 9/2004
 EP 1454650 A1 9/2004
 EP 1498097 A2 1/2005
 EP 1872824 A1 1/2008
 EP 1911432 A1 4/2008
 EP 1919432 A1 5/2008
 EP 1930038 A2 6/2008
 EP 2090278 A1 8/2009
 EP 2351548 A1 8/2011
 EP 2351549 A1 8/2011
 EP 2462913 A1 6/2012
 EP 2512399 A1 10/2012
 EP 2416739 B1 6/2016
 FR 2029242 A5 10/1970
 FR 2856660 A1 12/2004
 FR 2869795 A1 11/2005
 FR 2931363 A1 11/2009
 GB 1444210 A 7/1976
 IL 171662 10/2005
 IL 186290 1/2008
 IN 331018-001-0001 * 6/2021
 JP 03-062426 B2 9/1991
 JP 03-205560 A 9/1991
 JP 04-329954 A 11/1992
 JP 06-050656 U 7/1994
 JP 08-000710 A 1/1996
 JP 09-104460 A 4/1997
 JP 09-104461 A 4/1997
 JP 10-118158 A 5/1998
 JP 10-504736 A 5/1998
 JP 11-503627 A 3/1999
 JP 11-319031 A 11/1999
 JP 2000-508934 A 7/2000
 JP 2000-237278 A 9/2000
 JP 2000-262497 A 9/2000
 JP 2001-505083 A 4/2001
 JP 2002-035140 A 2/2002
 JP 2002-516160 A 6/2002
 JP 2002-355318 A 12/2002
 JP 2003-033441 A 2/2003
 JP 2003-102807 A 4/2003
 JP 2003-513709 A 4/2003
 JP 2004-501721 A 1/2004
 JP 2004-097253 A 4/2004
 JP 2004-522541 A 7/2004
 JP 2004-267776 A 9/2004
 JP 2005-270629 A 10/2005
 JP 2005-537048 A 12/2005
 JP 2006-061421 A 3/2006
 JP 2008-220961 A 9/2008
 JP 2009-513294 A 4/2009
 JP 4329954 B2 9/2009
 JP 2010-063622 A 3/2010
 JP 2010-179128 A 8/2010
 JP 2012-205769 A 10/2012
 JP 2013-520272 A 6/2013
 JP 2014-000220 A 1/2014
 JP 2015-211763 A 11/2015
 JP D201915749 7/2019
 WO 86/01487 A1 3/1986
 WO 86/01712 A1 3/1986
 WO 86/05683 A1 10/1986
 WO 90/03536 A1 4/1990
 WO 94/03373 A1 2/1994
 WO 95/07066 A1 3/1995

(56)

References Cited

FOREIGN PATENT DOCUMENTS

WO 9507720 A1 3/1995
 WO 9513785 A1 5/1995
 WO 96/00053 A1 1/1996
 WO 96/09083 A1 3/1996
 WO 96/29113 A1 9/1996
 WO 97/36636 A1 10/1997
 WO 98/32411 A1 7/1998
 WO 98/37854 A1 9/1998
 WO 99/61093 A1 12/1999
 WO 01/02490 A1 1/2001
 WO 01/28490 A1 4/2001
 WO 01/30425 A1 5/2001
 WO 01/32524 A1 5/2001
 WO 01/60311 A1 8/2001
 WO 01/89607 A2 11/2001
 WO 01/91693 A2 12/2001
 WO 02/02165 A2 1/2002
 WO 02/09797 A1 2/2002
 WO 02/32372 A1 4/2002
 WO 02/36191 A2 5/2002
 WO 02/66100 A2 8/2002
 WO 02/89900 A1 11/2002
 WO 03/51423 A2 6/2003
 WO 03/70147 A2 8/2003
 WO 03079956 A1 10/2003
 WO 2004/004806 A1 1/2004
 WO 2004/041148 A1 5/2004
 WO 2004/096113 A2 11/2004
 WO 2005/002492 A1 1/2005
 WO 2005/018703 A2 3/2005
 WO 2005/041846 A2 5/2005
 WO 2005/105014 A2 11/2005
 WO 2005120431 A1 12/2005
 WO 2006/099441 A2 9/2006
 WO 2006/124634 A1 11/2006
 WO 2007/015233 A1 2/2007
 WO 2007/017868 A1 2/2007
 WO 2007052252 A1 5/2007
 WO 2007/079305 A2 7/2007
 WO 2007/101772 A1 9/2007
 WO 2007/105221 A1 9/2007
 WO 2007/130809 A2 11/2007
 WO 2008/068756 A2 6/2008
 WO 2008/076459 A1 6/2008
 WO 2008081424 A2 7/2008
 WO 2008/126090 A1 10/2008
 WO 2008/135989 A1 11/2008
 WO 2009/026443 A2 2/2009
 WO 2009/029010 A1 3/2009
 WO 2009/038860 A2 3/2009
 WO 2009/040804 A2 4/2009
 WO 2009/087572 A1 7/2009
 WO 2009/093249 A1 7/2009
 WO 2009/112489 A1 9/2009
 WO 2009140511 A1 11/2009
 WO 2009/146088 A1 12/2009
 WO 2010061743 A1 6/2010
 WO 2010/078227 A1 7/2010
 WO 2010/117471 A2 10/2010
 WO 2010/117580 A1 10/2010
 WO 2011/004360 A1 1/2011
 WO 2011/024725 A1 3/2011
 WO 2011025719 A1 3/2011
 WO 2011/039747 A1 4/2011
 WO 2011/058545 A1 5/2011
 WO 2011/058548 A1 5/2011
 WO 2011/077434 A1 6/2011
 WO 2011/090955 A1 7/2011
 WO 2011/104711 A1 9/2011
 WO 2011/132657 A1 10/2011
 WO 2011/156373 A1 12/2011
 WO 2011150037 A1 12/2011
 WO 2012/004784 A1 1/2012
 WO 2012/004790 A2 1/2012
 WO 2012/063230 A1 5/2012

WO 2012/143921 A1 10/2012
 WO 2012/150587 A1 11/2012
 WO 2013/001525 A1 1/2013
 WO 2013/127813 A1 9/2013
 WO 2013/134246 A1 9/2013
 WO 2013/148435 A1 10/2013
 WO 2013/156944 A1 10/2013
 WO 2013/156994 A1 10/2013
 WO 2014/033706 A2 3/2014
 WO 2014/033710 A1 3/2014
 WO 2014/099395 A1 6/2014
 WO 2014/170888 A1 10/2014
 WO 2014/174278 A1 10/2014
 WO 2015009746 A2 1/2015
 WO 2015019343 A1 2/2015
 WO 2016/023590 A1 2/2016
 WO 2017/203512 A1 11/2017
 WO 2018/104932 A1 6/2018
 WO 2018104930 A1 6/2018
 WO 2018178971 A1 10/2018
 WO 2020/222220 A1 11/2020

OTHER PUBLICATIONS

Our Vial2Bag Advanced™ 20mm admixture device , West Pharma, WestPharma @twitter, [Post date Mar. 19, 2021], [Site seen Jan. 25, 2022], Seen at URL: <https://twitter.com/westpharma/status/1372921057766739971> (Year: 2021).*
 Vial2Bag Advanced™ 20mm Admixture , West Pharmaceutical Services Inc, Youtube, [post date Nov. 5, 2020], [Site seen Jan. 25, 2022], Seen at URL: <https://www.youtube.com/watch?v=J0Am3mt5vn8> (Year: 2020).*
 Summit International Medical Technologies, Inc., Vial Direct to Bag Spike, 2020.
 Merchant “An engineered control device for needle free reconstitution and transfer of compounded sterile intravenous drug solutions for immediate use to assist in complying with United States Pharmacopeia Chapter <797> standard”, Adv Care, 2 pages, 2018.
 West Vial2Bag DC system, Oct. 2, 2014, <https://web.archive.org/web/2014002065133/http://www.westpharma.com/en/products/Pages/Reconstitutionsystems.aspx>.
 Youtube.com, Vial2Bag DC, Aug. 21, 2014, <https://www.youtube.com/watch?v=FEOkglxNBrS>.
 Article with picture of West Pharmaceutical Services Vial2Bag Needleless System, [on-line]; IPIPS Newsletter, Oct. 26, 2007], [retrieved from Internet Feb. 16, 2010]; URL: http://www.isips.org/reports/ISIPS_Newsletter_October_26_2007.html.> (7 pages, see pp. 5-6).
 Int’l Search Report and Written Opinion issued Mar. 23, 2020 in Int’l Application No. PCT/IL2020/050048.
 Facebook “West Pharmaceutical Services, Inc.”, first available Oct. 21, 2014 (<https://www.facebook.com/westpharma/photos/710246859056351>)(2014).
 YouTube, “vial2Bag DC”, first available Feb. 1, 2018, (https://www.youtube.com/watch?v=abSKPo5e_Hg) (Year:2018).
 Youtube, “ADVCARE—Vial Direct to bag Spoke”, first available Oct. 31, 2018 (https://www.youtube.com/watch?v=dd8ctggkrfM&feature=emb_title)(2018).
 Int’l Preliminary Report on Patentability dated Aug. 24, 2015 in Int’l Application No. PCT/IL2014/050405.
 Int’l Search Report and Written Opinion dated Jul. 21, 2020 in Int’l Application No. PCT/IL2020/050362.
 Int’l Search Report and Written Opinion dated Mar. 29, 2019 in Int’l Application No. PCT/IB2018/059577.
 Int’l Search Report and Written Opinion dated May 4, 2011 in Int’l Application No. PCT/IL2010/001077.
 Int’l Search Report dated Apr. 24, 2020 in Int’l Application No. PCT/US2020/050020.
 Int’l Search Report dated Aug. 25, 2008 in Int’l Application No. PCT/IL2008/000517.
 Int’l Search Report dated Jan. 22, 2013 in Int’l Application No. PCT/IL2012/000354.
 Int’l Search Report dated Nov. 20, 2006 in Int’l Application No. PCT/IL2006/000881.

(56)

References Cited

OTHER PUBLICATIONS

International Search Report and Written Opinion dated Oct. 17, 2014 in International Application No. PCT/IL2014/050680.

International Search Report dated Jan. 23, 2007 in Int'l Application No. PCT/IL/2006/001228.

International Search Report dated Mar. 30, 2011 in Int'l Application No. PCT/IL2010/000939.

International Search Report dated Aug. 28, 2008 in Int'l Application No. PCT/IL2008/000606.

Intl Search Report dated Dec. 6, 2006 in Int'l Application No. PCT/IL2006/000912.

IV disposables sets catalogue, Cardinal Health, Alaris(Registered) products, SmartSite(Registered) access devices and accessories product No. 10013365, SmartSite add-on bag access device with spike adapter and needle-free valve bag access port, pp. 1-5, Fall edition (2007).

MixJect, downloaded from webpage: <http://www.westpharma.com/en/products/Pages/MixjecLaspx>, Download Date Aug. 8, 2012, 1 page.

MixJet Product Information Sheet, downloaded from webpage: <http://www.westpharma.com/SiteCollectionDocuments/Recon/mixject%20product%20sheet.pdf>; 1 page.

Non-Vented Vial Access Pin with ultrasite.rm. Valve, B. Braun Medical, Inc. website and product description, 3 pages, Feb. 2006.

Notice of Allowance dated Jan. 12, 2016 in U.S. Appl. No. 14/385,212 by Lev.

Notice of Allowance dated Mar. 17, 2016 in U.S. Appl. No. 29/502,037 by Lev.

Novel Transfer, Mixing and Drug Delivery System, MOP Medimop Medical Projects Ltd. Catalog, 4 pages, Rev. 4, 2004.

Office Action dated Apr. 17, 2014 in CN Application No. 201080051201.4.

Office Action dated Apr. 2, 2013 in U.S. Appl. No. 13/505,790.

Office Action dated Apr. 20, 2010 in U.S. Appl. No. 11/997,569.

Office Action dated Apr. 9, 2015 in U.S. Appl. No. 13/883,289 by Lev.

Office Action dated Aug. 20, 2013 in U.S. Appl. No. 13/576,461 by Lev.

Office Action dated Aug. 24, 2015 in U.S. Appl. No. 14/366,306 by Lev.

Office Action dated Aug. 3, 2011 in JP Application No. 2008-525719.

Office Action dated Aug. 7, 2015 in JP Application No. 2015-529206.

Office Action dated Dec. 13, 2010 in U.S. Appl. No. 12/293,122.

Office Action dated Dec. 20, 2010 in U.S. Appl. No. 12/063,176.

Office Action dated Dec. 23, 2010 in U.S. Appl. No. 29/334,696.

Office Action dated Dec. 9, 2015 in U.S. Appl. No. 29/478,723 by Lev.

Office Action dated Dec. 9, 2015 in U.S. Appl. No. 29/478,726 by Lev.

Office Action dated Feb. 13, 2014 in U.S. Appl. No. 13/884,981 by Denenburg.

Office Action dated Feb. 20, 2009 in U.S. Appl. No. 11/694,297.

Office Action dated Feb. 22, 2005 in U.S. Appl. No. 10/062,796.

Office Action dated Feb. 7, 2011 in U.S. Appl. No. 12/783,194.

Office Action dated Jan. 17, 2014 in CN Application No. 201180006534.X.

Office Action dated Jan. 2, 2014 in U.S. Appl. No. 13/505,881 by Lev.

Office Action dated Jan. 2, 2015 in U.S. Appl. No. 29/438,141 by Gilboa.

Office Action dated Jan. 20, 2010 in JP Application No. 2007-510229.

Office Action dated Jan. 23, 2013 in U.S. Appl. No. 12/112,490 by Zinger.

Office Action dated Jan. 5, 2015 in U.S. Appl. No. 29/413,220 by Lev.

Office Action dated Jul. 11, 2011 in U.S. Appl. No. 12/293,122.

Office Action dated Jul. 13, 2012 in U.S. Appl. No. 12/112,490 by Zinger.

Office Action dated Jul. 31, 2014 in U.S. Appl. No. 29/438,141 by Gilboa.

Office Action dated Jun. 1, 2010 in U.S. Appl. No. 11/568,421.

Office Action dated Jun. 14, 2012 in U.S. Appl. No. 29/376,980.

Office Action dated Jun. 15, 2011 in JP Application No. 2008-538492.

Office Action dated Jun. 15, 2012 in U.S. Appl. No. 29/413,170.

Decision to Grant dated Apr. 12, 2010 in EP Application No. 08738307.1.

Drug Administration Systems product information sheets; <http://www.westpharma.com/eu/en/products/Pages/Vial2Bag.aspx>; pp. 1-3.

English translation of an Office Action dated Apr. 28, 2014 in JP Application No. 2013-537257.

English translation of an Office Action dated Aug. 28, 2014 in JP Application No. 2013-168885.

English translation of an Office Action dated Dec. 25, 2013 in CN Application No. 201180006530.1.

English translation of an Office Action dated Dec. 4, 2013 in CN Application No. 201080051210.3.

English translation of an Office Action dated Feb. 4, 2014 in JP Application No. 2012-554468.

English translation of an Office Action dated Jan. 9, 2014 in JP Application No. 2010-526421.

English translation of an Office Action dated Jul. 26, 2013 in JP Application No. 2012-538464.

English translation of an Office Action dated Jun. 19, 2013 in JP Application No. 2012-531551.

English translation of an Office Action dated Jun. 30, 2014 in CN Application No. 201180052962.6.

English translation of an Office Action dated Sep. 10, 2013 in JP Application No. 2012-554468.

Extended European Search Report dated Jun. 3, 2014 in EP Application No. 08781828.2.

Grifols Vial Adapter Product Literature, 2 pages, Jan. 2002.

<http://www.westpharma.com/en/products/Pages/Mixject.aspx>, [Retrieved on Aug. 8, 2012].

<http://www.westpharma.com/eu/en/products/Pages/Vial2Bag.aspx>; Drug Administration Systems product information sheets pp. 1-3.

<http://www.westpharma.com/eu/SiteCollectionDocuments/Recon/mixject%20product%20sheet.pdf>; Mixject product information sheet p. 1, Sep. 10, 2010.

Int'l Preliminary Report on Patentability Issued Oct. 20, 2009 in Int'l Application No. PCT/IL2008/000517.

Int'l Preliminary Report on Patentability issued Jan. 14, 2014 in Int'l Application No. PCT/IL2012/050516.

Int'l Preliminary Report on Patentability issued May 6, 2008 in Int'l Application No. PCT/IL2006/001228.

Int'l Preliminary Report on Patentability issued May 12, 2014 in Int'l Application No. PCT/IL2013/050316.

Int'l Preliminary Report on Patentability issued Aug. 20, 2014 in Int'l Application No. PCT/IL2012/050407.

Int'l Preliminary Report on Patentability issued Aug. 28, 2012 in Int'l Application No. PCT/IL2011/000186.

Int'l Preliminary Report on Patentability issued Sep. 24, 2013 in Int'l Application No. PCT/IL2012/000354.

Int'l Preliminary Report on Patentability Issued Dec. 4, 2007 in Int'l Application No. PCT/IL2006/000912.

Int'l Preliminary Report on Patentability Issued Jun. 19, 2006 in Int'l Application No. PCT/IL2005/000376.

Int'l Preliminary Report on Patentability Issued Jun. 19, 2008 in Int'l Application No. PCT/IL2007/000343.

Int'l Search Report & Written Opinion dated Mar. 7, 2012 in Int'l Application No. PCT/IL2011/000829.

Int'l Search Report and Written Opinion dated Mar. 6, 2012 in Int'l Application No. PCT/IL2011/000834.

Int'l Search Report and Written Opinion dated May 8, 2014 in Int'l Application No. PCT/IL2013/050706.

Int'l Search Report and Written Opinion dated Jul. 16, 2014 in Int'l Application No. PCT/IL2014/050327.

Int'l Search Report and Written Opinion dated Sep. 2, 2014 in Int'l Application No. PCT/IL2014/050405.

(56)

References Cited

OTHER PUBLICATIONS

- Int'l Search Report dated Feb. 3, 2011 in Int'l Application No. PCT/IL2010/000777; Written Opinion.
- Int'l Search Report dated Mar. 17, 2011 in Int'l Application No. PCT/IL2010/000854; Written Opinion.
- Int'l Search Report dated Mar. 17, 2011 in Int'l Application No. PCT/IL2010/000915; Written Opinion.
- Int'l Search Report dated Mar. 18, 2013 in Int'l Application No. PCT/IL2012/050516.
- Int'l Search Report dated Jun. 5, 2013 in Int'l Application No. PCT/IL2012/050407.
- Int'l Search Report dated Jun. 19, 2013 in Int'l Application No. PCT/IL2013/050167.
- Int'l Search Report dated Jul. 1, 2013 in Int'l Application No. PCT/IL2013/050180.
- Int'l Search Report dated Jul. 26, 2013 in Int'l Application No. PCT/IL2013/050316.
- Int'l Search Report dated Jul. 31, 2013 in Int'l Application No. PCT/IL2013/050313.
- Int'l Search Report dated Aug. 16, 2012 in Int'l Application No. PCT/IL2012/000164.
- Int'l Search Report dated Oct. 17, 2005 in Int'l Application No. PCT/IL2005/000376.
- Int'l Search Report dated 10/17/2011 in Int'l Application No. PCT/IL2011/000511.
- Int'l Search Report dated Nov. 25, 2010 in Int'l Application No. PCT/IL2010/000530.
- Int'l Search Report dated Mar. 12, 2009 in Int'l Application No. PCT/IL2008/001278.
- Int'l Search Report dated Mar. 27, 09 in Int'l Application No. PCT/US2008/070024.
- Int'l Search Report dated Jul. 12, 2011 in Int'l Application No. PCT/IL2011/000186.
- Int'l Search Report dated Jul. 12, 2011 in Int'l Application No. PCT/IL2011/000187.
- Int'l Search Report dated Jul. 27, 2007 in Int'l Application No. PCT/IL2007/000343.
- Office Action dated Jun. 21, 2012 in U.S. Appl. No. 12/596,167.
- Office Action dated Jun. 8, 2010 in U.S. Appl. No. 12/112,490 by Zinger.
- Office Action dated Mar. 1, 2012 in CN Application No. 200880108283.4.
- Office Action dated Mar. 10, 2015 in EP Application No. 12 812 395.7.
- Office Action dated Mar. 13, 2012 in CA Application No. 2,563,643.
- Office Action dated Mar. 17, 2015 in U.S. Appl. No. 14/504,979 by Lev.
- Office Action dated Mar. 25, 2016 in U.S. Appl. No. 29/478,726 by Lev.
- Office Action dated Mar. 28, 2016 in JP Application No. 2016-507113.
- Office Action dated Mar. 6, 2012 in U.S. Appl. No. 12/678,928.
- Office Action dated May 12, 2011 in U.S. Appl. No. 12/063,176.
- Office Action dated May 27, 2010 in U.S. Appl. No. 11/559,152.
- Office Action dated May 28, 2015 in U.S. Appl. No. 14/391,792 by Lev.
- Office Action dated May 31, 2013 in U.S. Appl. No. 13/505,790.
- Office Action dated May 6, 2014 in U.S. Appl. No. 13/505,881 by Lev.
- Office Action dated Nov. 11, 2013 in IL Application No. 218730.
- Office Action dated Nov. 28, 2013 in IN Application No. 4348/DELNP/2008.
- Office Action dated Nov. 29, 2010 in U.S. Appl. No. 11/568,421.
- Office Action dated Oct. 5, 2005 in U.S. Appl. No. 10/062,796.
- Office Action dated Oct. 5, 2015 in U.S. Appl. No. 14/385,212 by Lev.
- Office Action dated Oct. 6, 2003 in U.S. Appl. No. 10/062,796.
- Office Action dated Oct. 8, 2013 in CN Application No. 201080043825.1.
- Office Action dated Sep. 28, 2010 in U.S. Appl. No. 12/112,490 by Zinger.
- Office Action issued Jul. 31, 2012 in U.S. Appl. No. 12/598,469.
- Office Action issued May 25, 2021 issued in Japanese Application No. 2020-553506.
- Overview—Silicone Rubber [retrieved from http://www.knovel.com/web/portal/browse/display?_EXT_KNOVEL_DISPLAY_bookid=1023&VerticalID=0 on Feb. 9, 2011].
- Photographs of Alaris Medical Systems SmartSite.RTM. device, 5 pages, 2002.
- Publication date of Israeli Patent Application 186290 [on-line]. [Retrieved from Internet May 24, 2010]. URL: <<http://www.ilpatsearch.justice.gov.il/UI/Requestslist.aspx>>. (1 page).
- Smart Site Needle-Free Systems, Alaris Medical Systems Webpage, 4 pages, Feb. 2006.
- Smart Site.RTM. Alaris Medical Systems Product Brochure, 4 pages, Issue 1, Oct. 1999.
- The MixJect transfer system, as shown in the article, "Advanced Delivery Devices," Drug Delivery Technology Jul./Aug. 2007 vol. 7 No. 7 [on-line]. [Retrieved from Internet May 14, 2010.] URL: <<http://www.drugdeliverytech-online.com/drugdelivery/200707/?pg=28pg28>>. (3 pages).
- Translation of Office Action dated Apr. 15, 2013 in JP Application No. 2008-538492.
- Translation of Office Action dated Jun. 18, 2012 in JP Application No. 2008-538492.
- U.S. Appl. No. 14/005,751 by Denenburg, filed Sep. 17, 2013.
- U.S. Appl. No. 13/505,790 by Lev, filed May 3, 2012.
- U.S. Appl. No. 13/505,881 by Lev, filed May 3, 2012.
- U.S. Appl. No. 13/522,410 by Lev, filed Jul. 16, 2012.
- U.S. Appl. No. 13/576,461 by Lev, filed Aug. 1, 2012.
- U.S. Appl. No. 13/883,289 by Lev, filed May 3, 2013.
- U.S. Appl. No. 13/884,981 by Denenburg, filed May 13, 2013.
- U.S. Appl. No. 14/345,094 by Lev, filed Mar. 14, 2014.
- U.S. Appl. No. 14/366,306 by Lev, filed Jun. 18, 2014.
- U.S. Appl. No. 14/385,212 by Lev, filed Sep. 15, 2014.
- U.S. Appl. No. 14/391,792 by Lev, filed Oct. 10, 2014.
- U.S. Appl. No. 14/423,595 by Lev, filed Feb. 24, 2015.
- U.S. Appl. No. 14/423,612 by Lev, filed Feb. 24, 2015.
- U.S. Appl. No. 14/425,582 by Lev, filed Mar. 3, 2015.
- U.S. Appl. No. 14/504,979 by Lev, filed Oct. 2, 2014.
- U.S. Appl. No. 14/784,300 by Lev, filed Oct. 14, 2015.
- U.S. Appl. No. 14/888,590 by Marks, filed Nov. 2, 2015.
- U.S. Appl. No. 29/438,134 by Lev, filed Nov. 27, 2012.
- U.S. Appl. No. 29/438,141 by Gilboa, filed Nov. 27, 2012.
- U.S. Appl. No. 29/478,723 by Lev, filed Jan. 8, 2014.
- U.S. Appl. No. 29/478,726 by Lev, filed Jan. 8, 2014.
- U.S. Appl. No. 29/502,037 by Lev, filed Sep. 11, 2014.
- U.S. Appl. No. 29/502,053 by Lev, filed Sep. 11, 2014.
- U.S. Appl. No. 29/544,969 by Ben Shalom, filed Nov. 9, 2015.
- Vial-Mate Adapter Device, Baxter, May 2017, downloaded from web page: <http://www.baxtermedicationdeliveryproducts.com/drug-delivery/vialmate.html>, Download Date: Jul. 28, 2017, original posting date: unknown, 1 page.
- Vial2Bag DC, downloaded from webpage: <https://www.youtube.com/watch?v=FE0kg1xNBrs>, Original posting date Aug. 21, 2014, 1 page.
- Written Opinion dated Aug. 16, 2012 in Int'l Application No. PCT/IL2012/000164.
- Written Opinion dated Jul. 31, 2013 in Int'l Application No. PCT/IL2013/050313.
- Written Opinion dated Jun. 5, 2013 in Int'l Application No. PCT/IL2012/050407.
- Written Opinion of ISR dated Jun. 19, 2006 in Int'l Application No. PCT/IL2005/000376.
- Written Opinion of the Int'l Searching Authority dated Oct. 27, 2008 in Int'l Application No. PCT/US2008/070024.
- Written Opinion of the ISR dated Oct. 17, 2009 in Int'l Application No. PCT/IL08/00517.

(56)

References Cited

OTHER PUBLICATIONS

Youtube, "Vial2Bag.RTM. Needleless IV Transfer System from Helapet Ltd", first available Aug. 21, 2014 (<https://www.youtube.com/watch?v=yFejsv0eemE>) (Year: 2014).

* cited by examiner

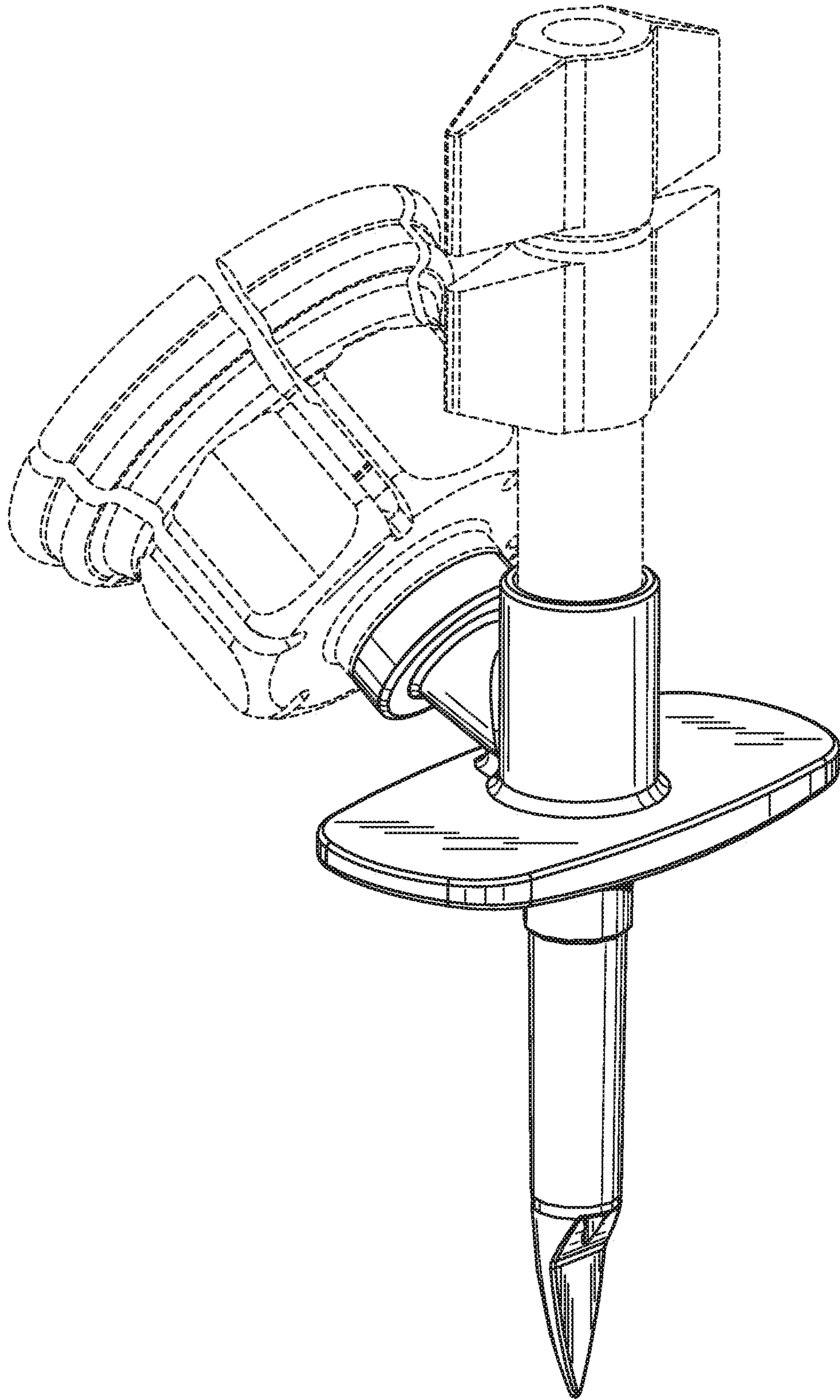

FIG. 1

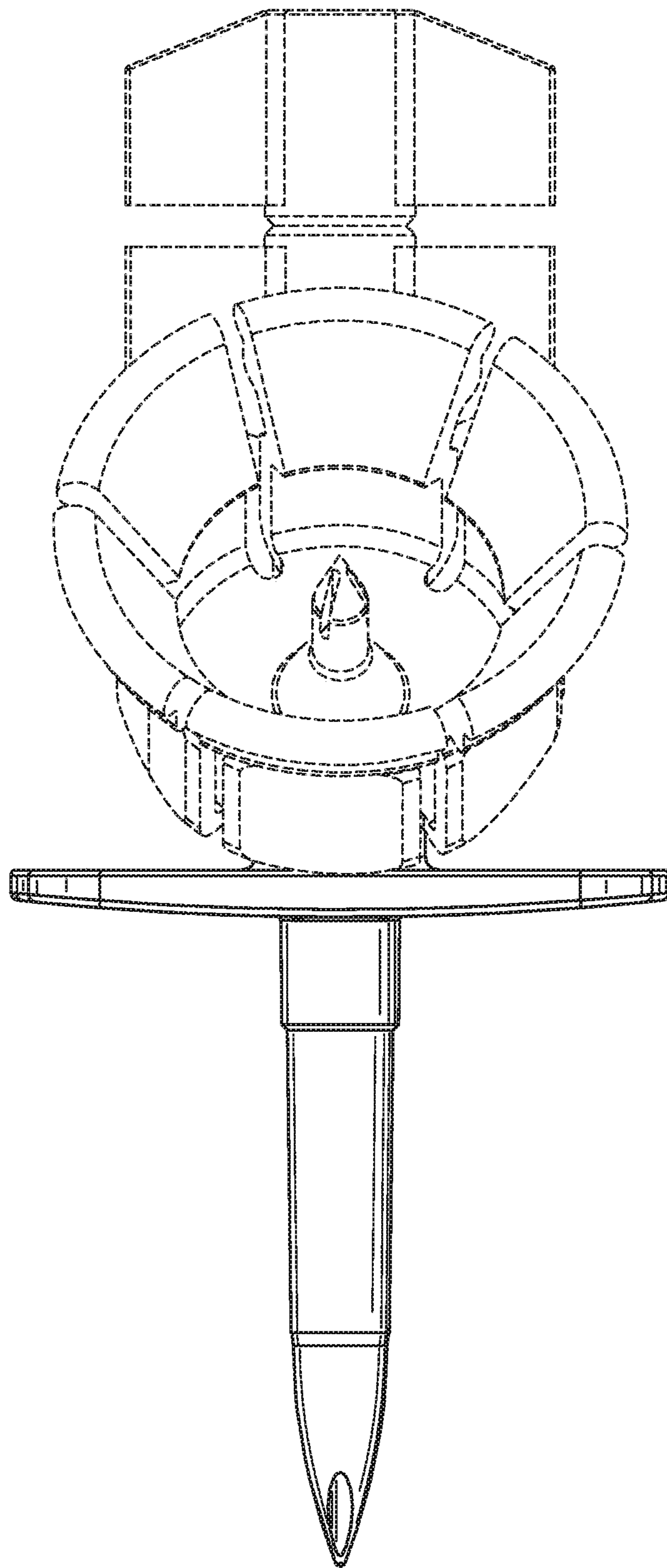

FIG. 2

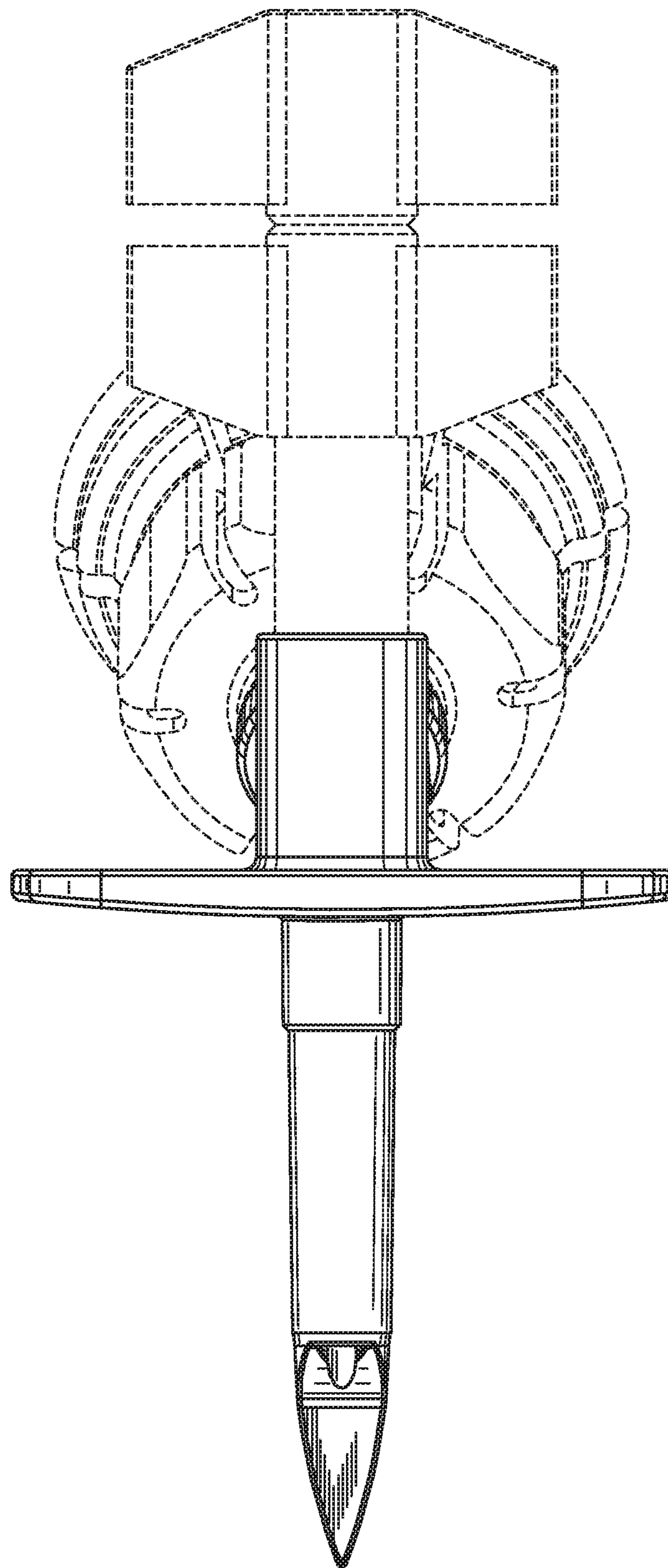

FIG. 3

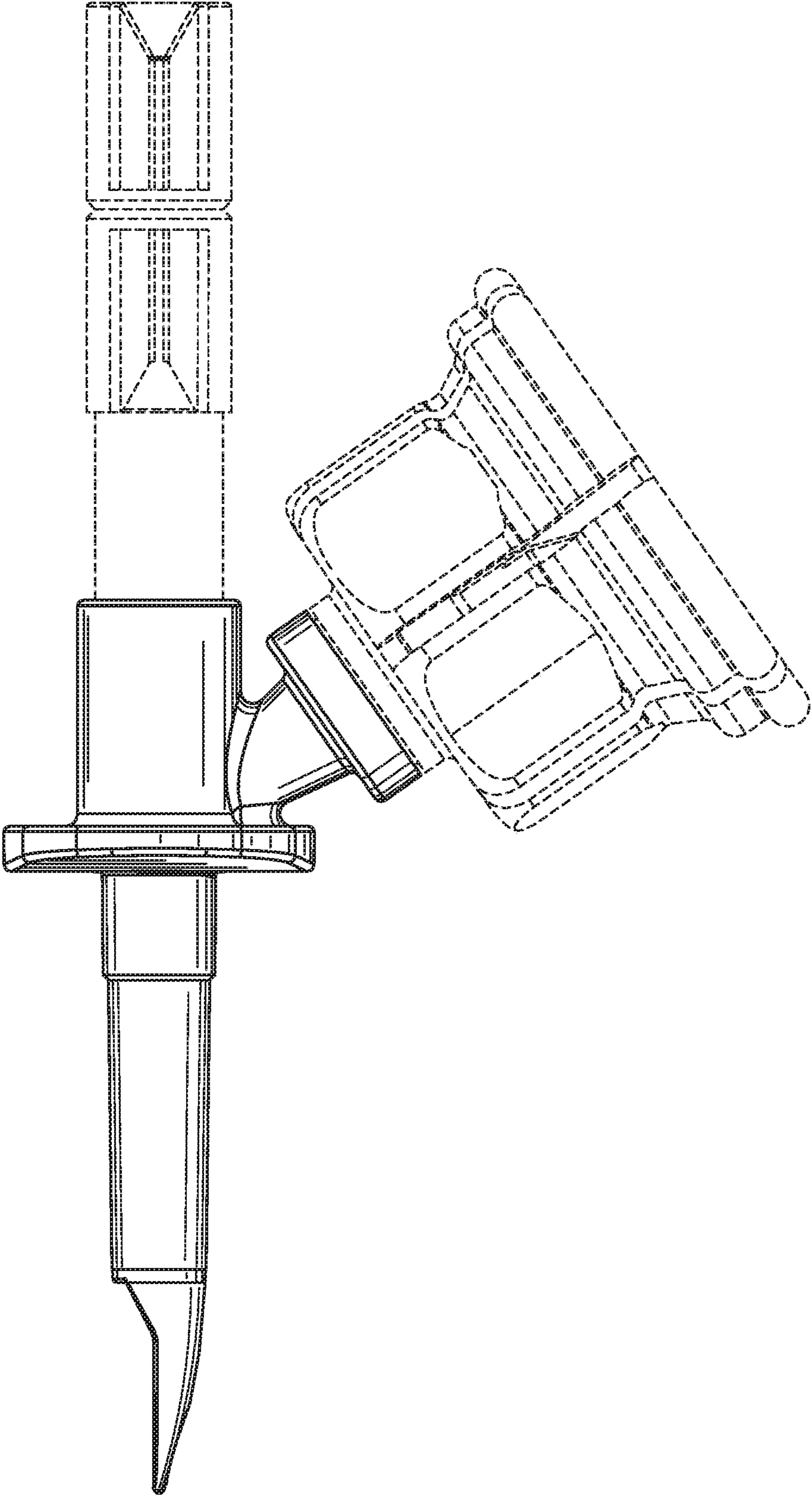

FIG. 4

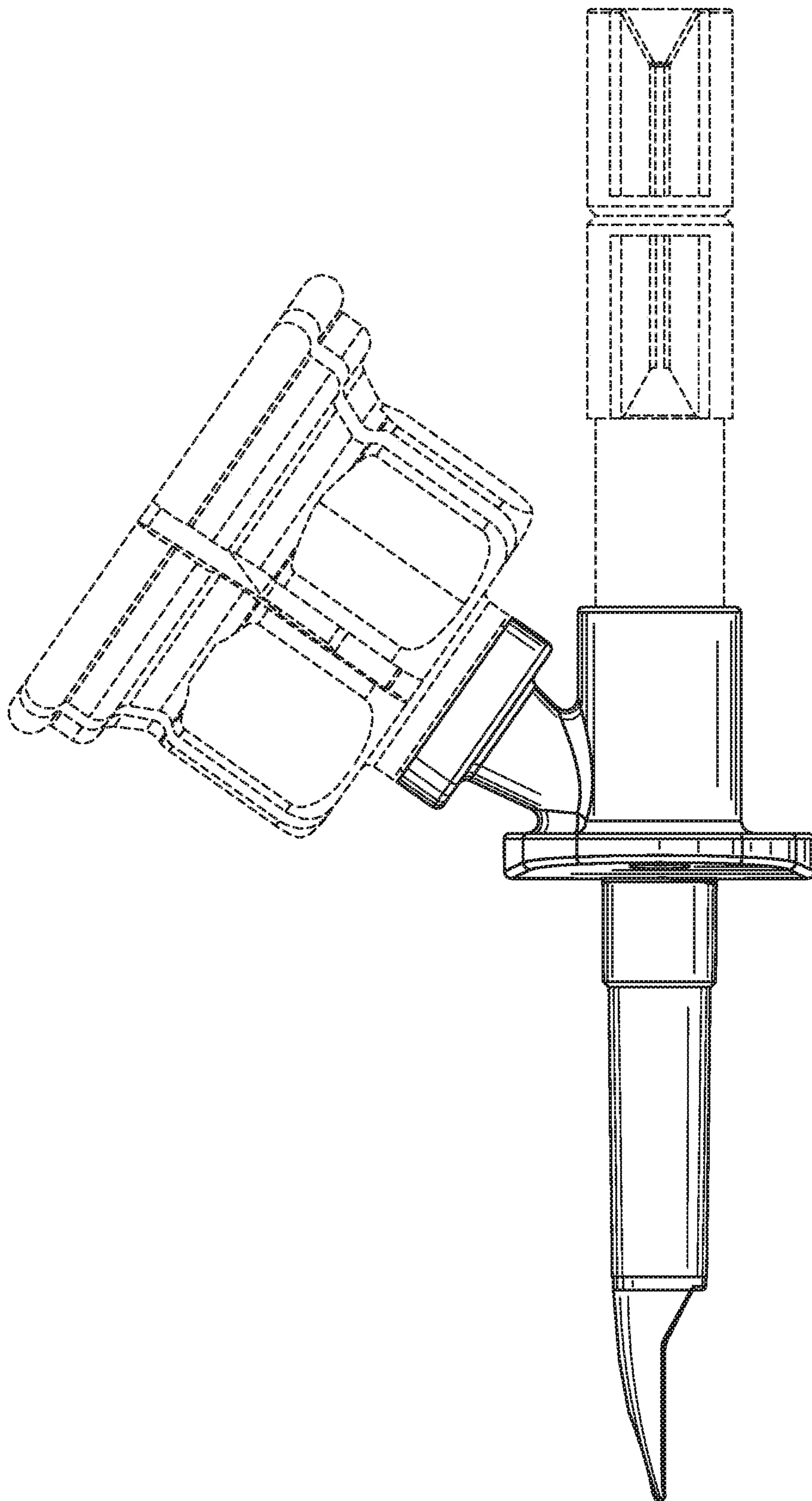

FIG. 5

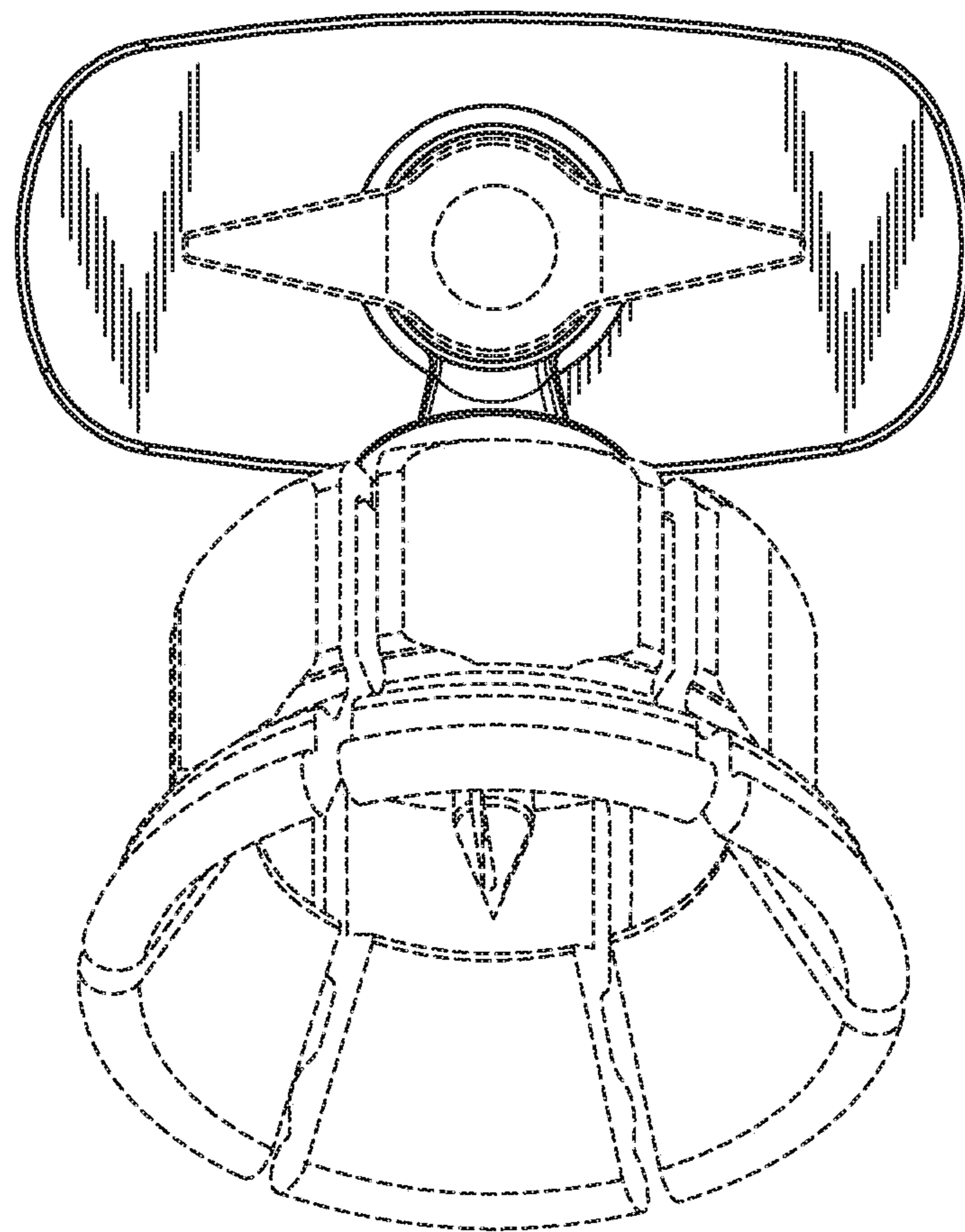

FIG. 6

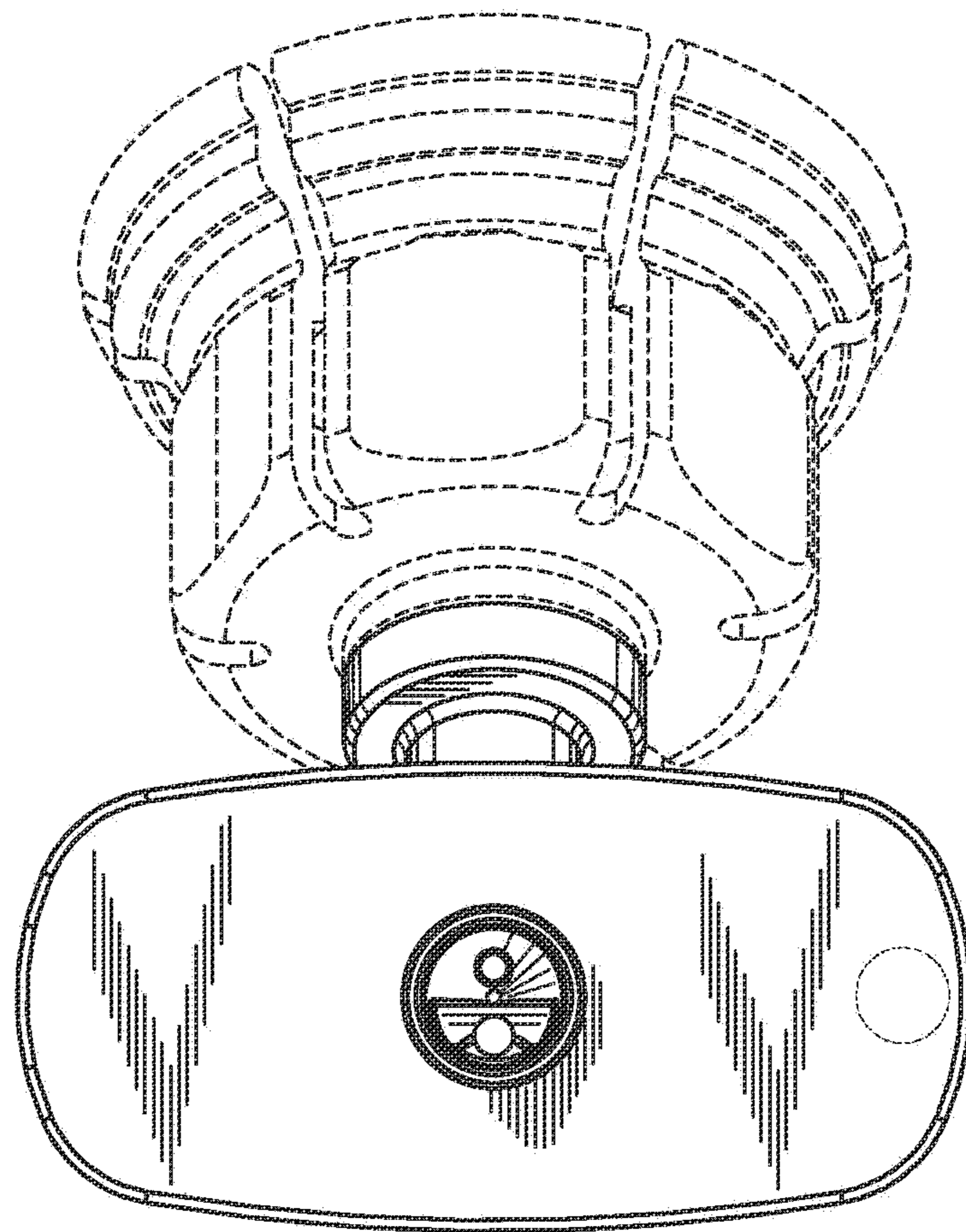

FIG. 7