



US00D955952S

(12) **United States Design Patent**  
**Lopera et al.**

(10) **Patent No.:** **US D955,952 S**  
(45) **Date of Patent:** **\*\* Jun. 28, 2022**

(54) **DOOR FOR A UTILITY VEHICLE**

- (71) Applicant: **Polaris Industries Inc.**, Medina, MN (US)
- (72) Inventors: **R. Mark Lopera**, Lake Elsinore, CA (US); **Jeremy M. Brown**, Menifee, CA (US); **Steven D. Wilcox**, Moreno Valley, CA (US)
- (73) Assignee: **Polaris Industries Inc.**, Medina, MN (US)
- (\*\*) Term: **15 Years**

(21) Appl. No.: **29/699,429**

(22) Filed: **Jul. 25, 2019**

(51) **LOC (13) Cl.** ..... **12-16**

(52) **U.S. Cl.**  
USPC ..... **D12/196**

(58) **Field of Classification Search**  
 USPC ..... D12/3, 4, 5, 14, 85, 86, 87, 90, 91, 92, D12/107, 184, 196  
 CPC ..... B62D 24/00; B62D 24/02; B62D 25/02; B62D 25/18; B62D 25/08; B62D 35/00; B60J 5/04; B60R 19/02; B60R 19/04  
 See application file for complete search history.

(56) **References Cited**

**U.S. PATENT DOCUMENTS**

- 3,422,918 A 1/1969 Musser et al.
- 3,600,768 A 8/1971 Romanzi et al.
- 3,663,057 A 5/1972 Lohr
- 3,758,159 A 9/1973 Morris

(Continued)

**FOREIGN PATENT DOCUMENTS**

- DE 0037435 10/1886
- DE 102009038853 A1 3/2011

(Continued)

**OTHER PUBLICATIONS**

International Search Report and Written Opinion issued by the International Searching Authority, dated Jun. 15, 2009, for International Patent Application No. PCT/US2009/000677; 23 pages.

(Continued)

*Primary Examiner* — Darlington Ly

(74) *Attorney, Agent, or Firm* — Faegre Drinker Biddle & Reath LLP

(57) **CLAIM**

We claim the ornamental design for a door for a utility vehicle, as shown and described.

**DESCRIPTION**

FIG. 1 is a left, front perspective view of a door for a utility vehicle embodying our new design in accordance to a first embodiment of the present application;  
 FIG. 2 is a right, rear perspective view thereof;  
 FIG. 3 is a left side elevation view thereof;  
 FIG. 4 is a right side elevation view thereof;  
 FIG. 5 is a front elevation view thereof;  
 FIG. 6 is a rear elevation view thereof;  
 FIG. 7 is a top plan view thereof;  
 FIG. 8 is a bottom plan view thereof;  
 FIG. 9 is a left, front perspective view of a door for a utility vehicle embodying our new design in accordance to a second embodiment of the present application;  
 FIG. 10 is a right, rear perspective view thereof;  
 FIG. 11 is a left side elevation view thereof;  
 FIG. 12 is a right side elevation view thereof;  
 FIG. 13 is a front elevation view thereof;  
 FIG. 14 is a rear elevation view thereof;  
 FIG. 15 is a top plan view thereof; and,  
 FIG. 16 is a bottom plan view thereof.  
 The portions of the door for the utility vehicle shown in broken lines form no part of the claimed design.

**1 Claim, 16 Drawing Sheets**

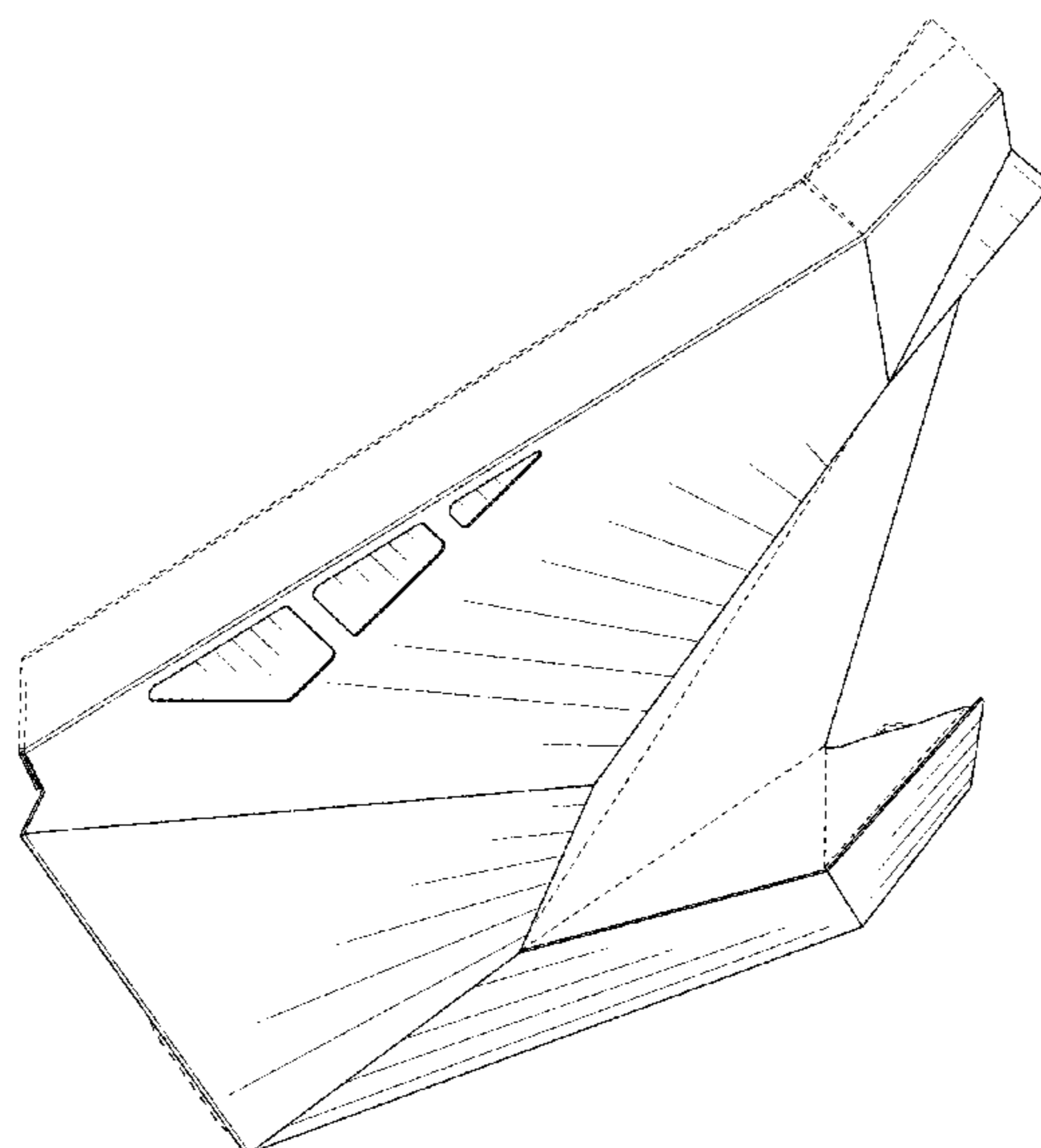

(56)

References Cited

U.S. PATENT DOCUMENTS

4,046,403	A	9/1977	Yoshida	8,465,050	B1	6/2013	Spindler et al.
4,455,049	A	6/1984	Martin	8,548,710	B1	10/2013	Reisenberger
4,650,210	A	3/1987	Hirose et al.	8,596,405	B2	12/2013	Sunsdahl et al.
4,817,985	A	4/1989	Enokimoto et al.	8,613,335	B2	12/2013	Deckard et al.
5,306,044	A	4/1994	Tucker	8,640,814	B2	2/2014	Deckard et al.
5,327,989	A	7/1994	Furuhashi et al.	8,781,705	B1	7/2014	Reisenberger
5,738,471	A	4/1998	Zentner et al.	8,827,025	B2	9/2014	Hapka
5,752,791	A	5/1998	Ehrlich	8,827,028	B2	9/2014	Sunsdahl et al.
5,816,650	A	10/1998	Lucas, Jr.	8,905,435	B2	12/2014	Ripley
5,895,063	A	4/1999	Hasshi et al.	8,998,289	B2 *	4/2015	Peterson ..... E05D 5/14
5,964,172	A	10/1999	Ikeda				296/146.11
5,997,069	A	12/1999	Coffey	9,327,587	B2 *	5/2016	Spindler ..... B60G 3/00
6,086,158	A	7/2000	Zeoli	9,393,894	B2	7/2016	Steinmetz
6,113,328	A	9/2000	Claucherty	D762,522	S *	8/2016	Kinoshita ..... D12/87
6,293,588	B1	9/2001	Clune	9,573,561	B2	2/2017	Muto et al.
6,293,610	B1	9/2001	Howard	9,694,650	B1 *	7/2017	Ohshita ..... B60H 1/243
6,295,713	B1	10/2001	Hilliard et al.	9,718,351	B2	8/2017	Ripley
6,309,024	B1	10/2001	Busch	9,725,023	B2 *	8/2017	Miller ..... B60K 11/06
6,354,663	B1	3/2002	Zhang	9,776,481	B2 *	10/2017	Deckard ..... B60N 2/24
6,375,245	B1	4/2002	Seibold	9,822,562	B2 *	11/2017	Borth ..... B60J 5/0487
D467,200	S	12/2002	Luo et al.	D804,993	S *	12/2017	Eek ..... D12/87
6,582,004	B1	6/2003	Hamm	D805,982	S *	12/2017	Ito ..... D12/196
6,755,269	B1	6/2004	Davis	D835,545	S *	12/2018	Hanten ..... D12/87
D497,324	S	10/2004	Chestnut et al.	10,369,861	B2	8/2019	Deckard
6,868,584	B2	3/2005	Trottier	10,369,869	B2 *	8/2019	Mazzarelli ..... B60J 5/0487
D503,657	S	4/2005	Katoh	D868,659	S *	12/2019	Mikhailov ..... D12/196
D504,638	S	5/2005	Tanaka et al.	10,583,796	B2 *	3/2020	Osorio ..... B60J 5/0487
D506,961	S *	7/2005	Sugimoto ..... D12/186	10,632,823	B1 *	4/2020	Osorio ..... E05B 79/12
D511,317	S	11/2005	Tanaka et al.	D883,163	S *	5/2020	McMath ..... D12/196
7,014,241	B2	3/2006	Toyota et al.	D883,164	S *	5/2020	McMath ..... D12/196
7,121,371	B2	10/2006	Rondeau	D889,343	S *	7/2020	Bertin ..... D12/196
7,258,192	B2	8/2007	Davis	10,737,596	B2	8/2020	Zou
7,281,753	B2	10/2007	Curtis et al.	10,780,766	B2 *	9/2020	Hagedorn ..... E05D 11/1085
D555,036	S	11/2007	Eck	D901,350	S *	11/2020	Marti Sala ..... D12/196
D555,058	S *	11/2007	Curtis, Jr. .... D12/196	D903,565	S *	12/2020	Peplowski ..... D12/196
D557,191	S *	12/2007	Curtis, Jr. .... D12/196	2001/0031185	A1	10/2001	Swensen
7,331,418	B2	2/2008	Audet	2002/0135175	A1	9/2002	Schroth
7,377,570	B2	5/2008	Rondeau	2003/0151278	A1	8/2003	Bertrand
D578,433	S	10/2008	Kawaguchi et al.	2003/0233732	A1	12/2003	Kohlstrand et al.
D578,934	S	10/2008	Tanaka et al.	2004/0031640	A1	2/2004	Tweet
7,431,024	B2	10/2008	Buchwitz et al.	2004/0112668	A1	6/2004	Rondeau
7,506,714	B2	3/2009	Davis	2004/0232684	A1	11/2004	Curl
D592,998	S	5/2009	Woodard et al.	2004/0239088	A1	12/2004	Rondeau
D595,613	S	7/2009	Lai et al.	2005/0073187	A1	4/2005	Frank et al.
7,596,448	B2	9/2009	Suzuki	2005/0077098	A1	4/2005	Takayanagi et al.
7,597,385	B2 *	10/2009	Shibata ..... B60J 10/80 296/190.11	2005/0173177	A1	8/2005	Smith et al.
D604,201	S	11/2009	Kawaguchi et al.	2005/0247506	A1	11/2005	Rondeau
D605,555	S	12/2009	Tanaka et al.	2005/0279330	A1	12/2005	Okazaki et al.
D606,900	S	12/2009	Flores	2006/0006696	A1	1/2006	Umemoto et al.
7,625,048	B2	12/2009	Rouhana et al.	2006/0066122	A1	3/2006	Wiseman
D607,377	S	1/2010	Shimomura et al.	2007/0214818	A1	9/2007	Nakamura
7,677,646	B2	3/2010	Nakamura	2007/0257503	A1	11/2007	Ball
7,717,495	B2	5/2010	Leonard et al.	2008/0012380	A1	1/2008	Takahana
D621,423	S	8/2010	Nakanishi et al.	2008/0023249	A1	1/2008	Sunsdahl et al.
D622,631	S	8/2010	Lai et al.	2008/0084091	A1	4/2008	Nakamura et al.
7,795,602	B2	9/2010	Leonard et al.	2008/0093883	A1	4/2008	Shibata et al.
D624,848	S	10/2010	Shimomura	2008/0231090	A1	9/2008	Takeda
D625,662	S	10/2010	Li	2008/0256738	A1	10/2008	Malone
7,819,220	B2	10/2010	Sunsdahl et al.	2008/0296884	A1	12/2008	Rouhana et al.
7,832,770	B2	11/2010	Bradley et al.	2009/0184531	A1	7/2009	Yamamura et al.
D631,395	S	1/2011	Tandrup et al.	2009/0301830	A1	12/2009	Kinsman et al.
D631,791	S *	2/2011	Sanschagrín ..... D12/14	2010/0084212	A1	4/2010	Smith
D633,006	S	2/2011	Sanschagrín et al.	2010/0090797	A1	4/2010	Koenig et al.
7,913,505	B2	3/2011	Nakamura	2010/0194086	A1	8/2010	Yamamura et al.
D636,704	S	4/2011	Yoo et al.	2010/0314184	A1	12/2010	Stenberg et al.
D640,598	S	6/2011	Zhang	2010/0314191	A1	12/2010	Deckard et al.
D641,288	S	7/2011	Sun	2011/0155087	A1	6/2011	Wenger et al.
D642,493	S	8/2011	Goebert et al.	2011/0297462	A1	12/2011	Grajkowski et al.
7,988,210	B2 *	8/2011	Shibata ..... E05B 85/045 292/340	2011/0309118	A1	12/2011	Wada
8,052,202	B2	11/2011	Nakamura	2012/0031693	A1	2/2012	Deckard et al.
8,215,694	B2	7/2012	Smith et al.	2012/0223500	A1	9/2012	Kinsman et al.
8,328,235	B2	12/2012	Schneider et al.	2013/0033070	A1	2/2013	Kinsman et al.
8,464,824	B1	6/2013	Reisenberger	2013/0047400	A1	2/2013	L'Huillier
				2013/0062909	A1	3/2013	Harris
				2013/0199097	A1	8/2013	Spindler et al.
				2013/0319785	A1	12/2013	Spindler et al.
				2014/0103627	A1	4/2014	Deckard et al.
				2014/0353956	A1	12/2014	Bjerketvedt et al.
				2015/0014974	A1	1/2015	Cotnoir et al.

(56)

**References Cited**

U.S. PATENT DOCUMENTS

2015/0175114	A1	6/2015	Schroeder et al.
2015/0259011	A1	9/2015	Deckard
2016/0032625	A1	2/2016	Suzuki
2018/0065465	A1	3/2018	Ward et al.
2018/0147966	A1	5/2018	Reed
2019/0210484	A1	7/2019	Deckard
2019/0210668	A1	7/2019	Endrizzi et al.
2019/0263294	A1	8/2019	Nishiguchi

FOREIGN PATENT DOCUMENTS

EP	1493624	A1	1/2005
EP	1878645		1/2008
EP	2057060	A2	5/2009
FR	2914597	A1	10/2008
GB	2036659	A	7/1980
JP	07-040783	A	2/1995
JP	2001-130304	A	5/2001
JP	2003-237530	A	8/2003
JP	2010-095106	A	4/2010
JP	6325977	B2	5/2018
WO	2008/016377	A2	2/2008
WO	2019/140026	A1	7/2019

OTHER PUBLICATIONS

Arctic Cat, Company Website, Prowler XT650 H1, undated; 9 pages.  
 BRP Can-Am Commander photo, undated; 1 page.  
 Buyer's Guide Supplement, 2006 Kart Guide, Powersports Business Magazine; 6 pages.  
 Club Car, Company Website, product pages for XRT 1500 SE, undated; 2 pages.  
 Honda Hippo 1800 New Competition for Yamaha's Rhino, Dirt Wheels Magazine, Apr. 2006, pp. 91-92.  
 International Preliminary Report and Patentability issued by the European Patent Office, dated Apr. 14, 2015, for International Patent Application No. PCT/US2013/064516; 18 pages.  
 International Preliminary Report on Patentability issued by the European Patent Office, dated Mar. 8, 2013, for International Patent Application No. PCT/US2012/024664; 24 pages.

International Preliminary Report on Patentability issued by the European Patent Office, dated Nov. 4, 2014, for International Patent Application No. PCT/US2013/039304; 7 pages.  
 International Search Report and Written Opinion issued by the European Patent Office, dated Jan. 14, 2014, for International Patent Application No. PCT/US2013/064516; 23 pages.  
 International Search Report and Written Opinion issued by the European Patent Office, dated Jul. 23, 2013, for International Patent Application No. PCT/US2013/039304; 11 pages.  
 International Search Report and Written Opinion issued by the European Patent Office, dated Jun. 28, 2012, for International Patent Application No. PCT/US2012/024664; 19 pages.  
 Kawasaki Mule The Off-Road Capable 610 4x4 XC Brochure 2011, copyright 2010; 6 pages.  
 Kawasaki Mule Utility Vehicle Brochure 2009, copyright 2008; 10 pages.  
 Kawasaki Teryx 750 FI 4x4 Sport Brochure 2011, copyright 2010; 6 pages.  
 Kawasaki Teryx Recreation Utility Vehicle Brochure 2009, copyright 2008; 8 pages.  
 New for 2004, Yamaha Rhino 660 4x4, ATV Connection Magazine, copyright 2006; 3 pages.  
 Patent Examination Report issued by the Australian Government IP Australia, dated Apr. 7, 2016, for Australian Patent Application No. 2013329090; 3 pages.  
 Polaris Ranger Brochure 2009, copyright 2008; 32 pages.  
 Polaris Ranger Brochure ATVs and Side x Side Brochure 2010, copyright 2009; 26 pages.  
 Polaris Ranger Off-Road Utility Vehicles Brochure 2004, copyright 2003; 20 pages.  
 Polaris Ranger RZR Brochure 2011, copyright 2010; 16 pages.  
 Polaris Ranger Welcome to Ranger Country Brochure 2006, copyright 2005; 24 pages.  
 Polaris Ranger Work/Play Only Brochure 2008, copyright 2007; 28 pages.  
 Yamaha, Company Website, 2006 Rhino 450 Auto 4x4, copyright 2005; 3 pages.  
 Yamaha, Company Website, 2006 Rhino 660 Auto 4x4 Special Edition, copyright 2006; 4 pages.

\* cited by examiner

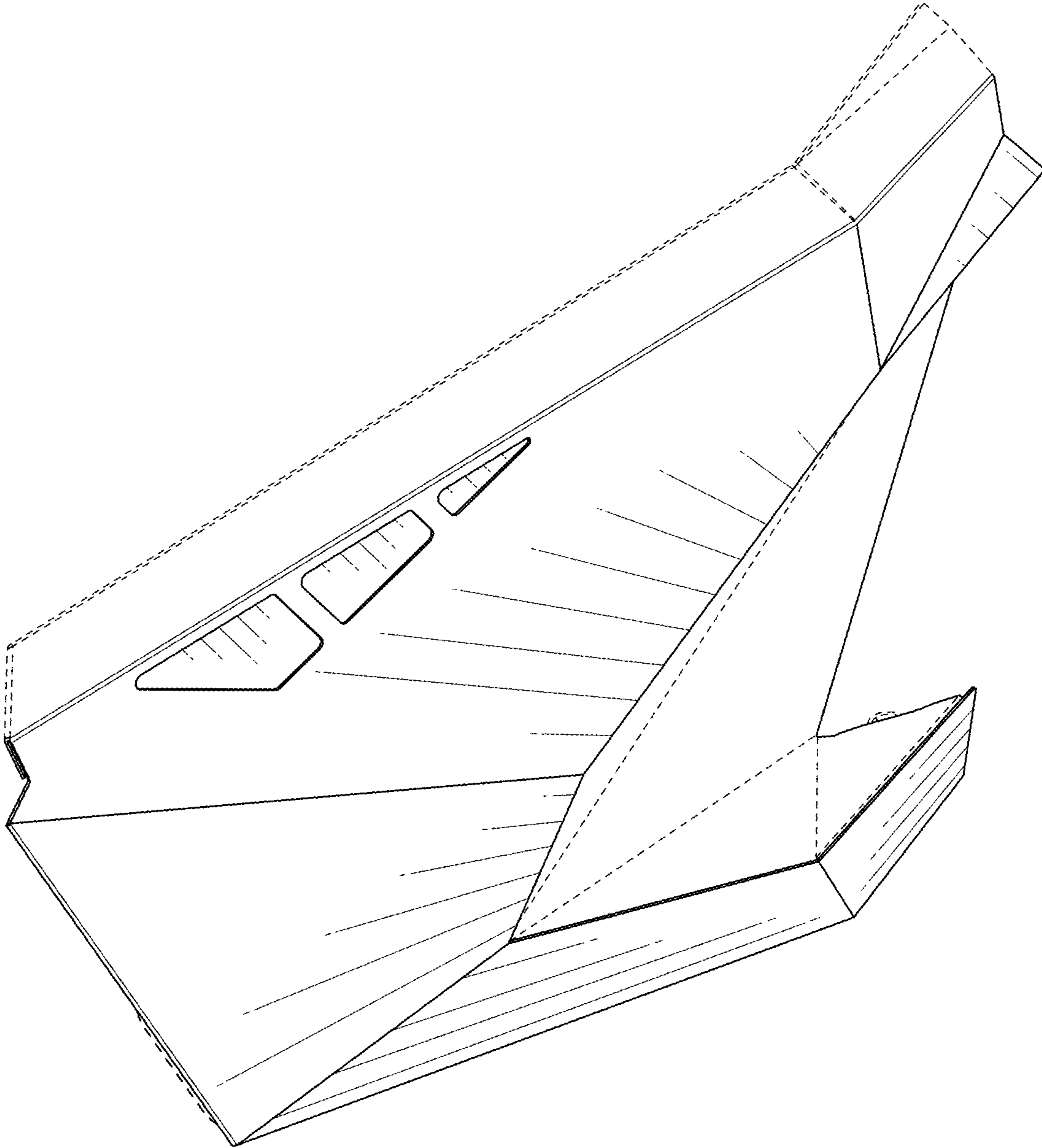

FIG. 1

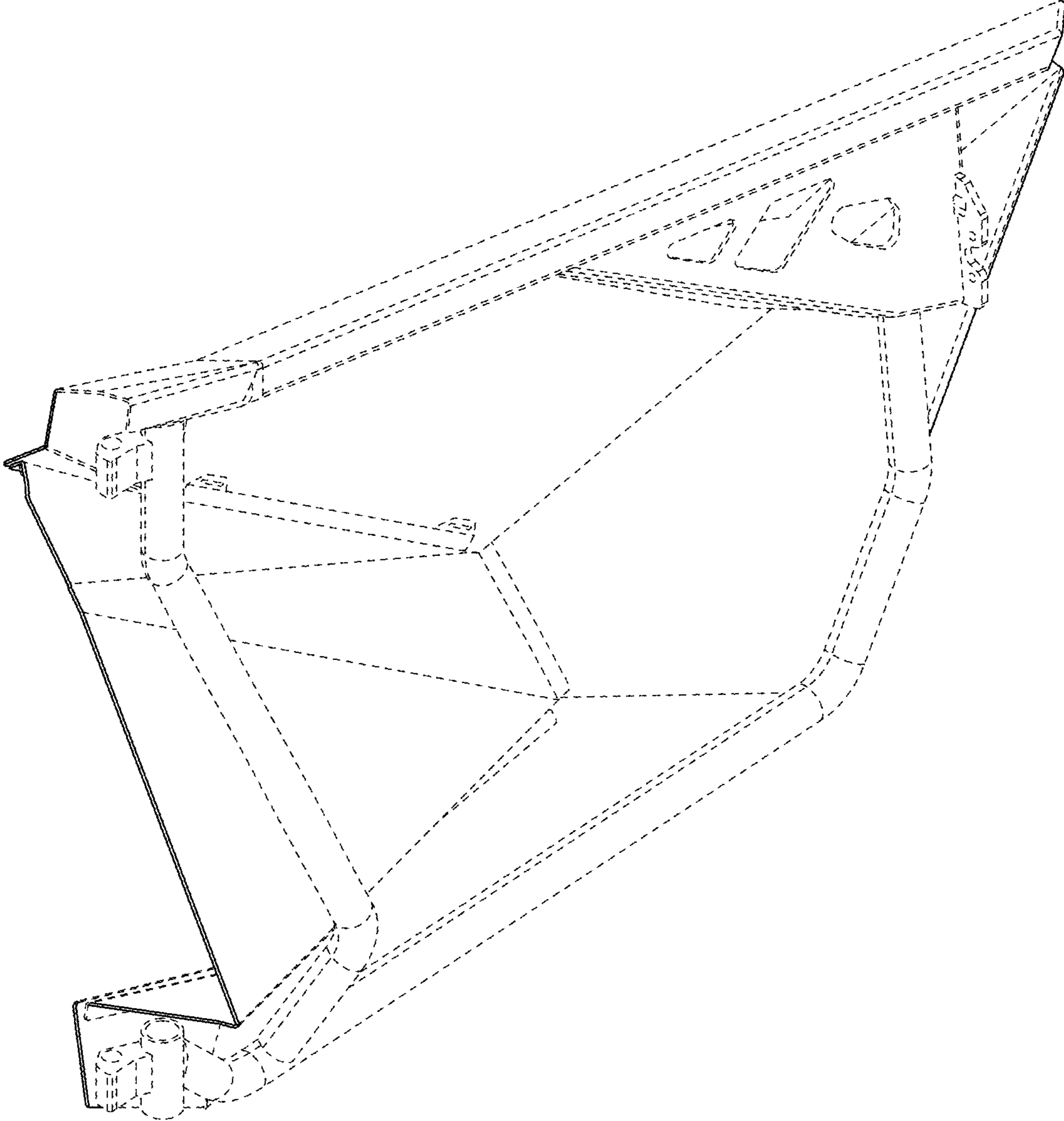

FIG. 2

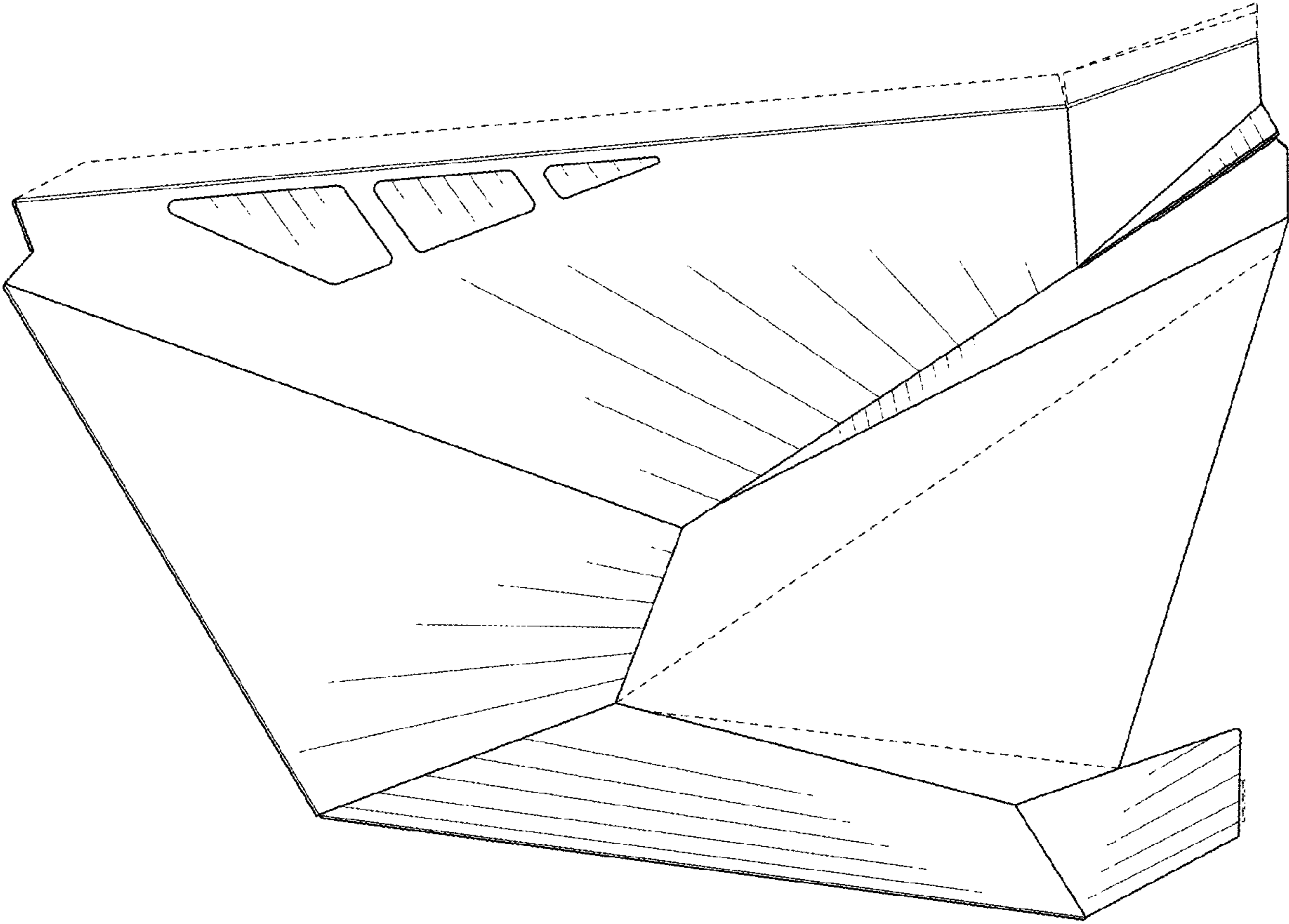

FIG. 3

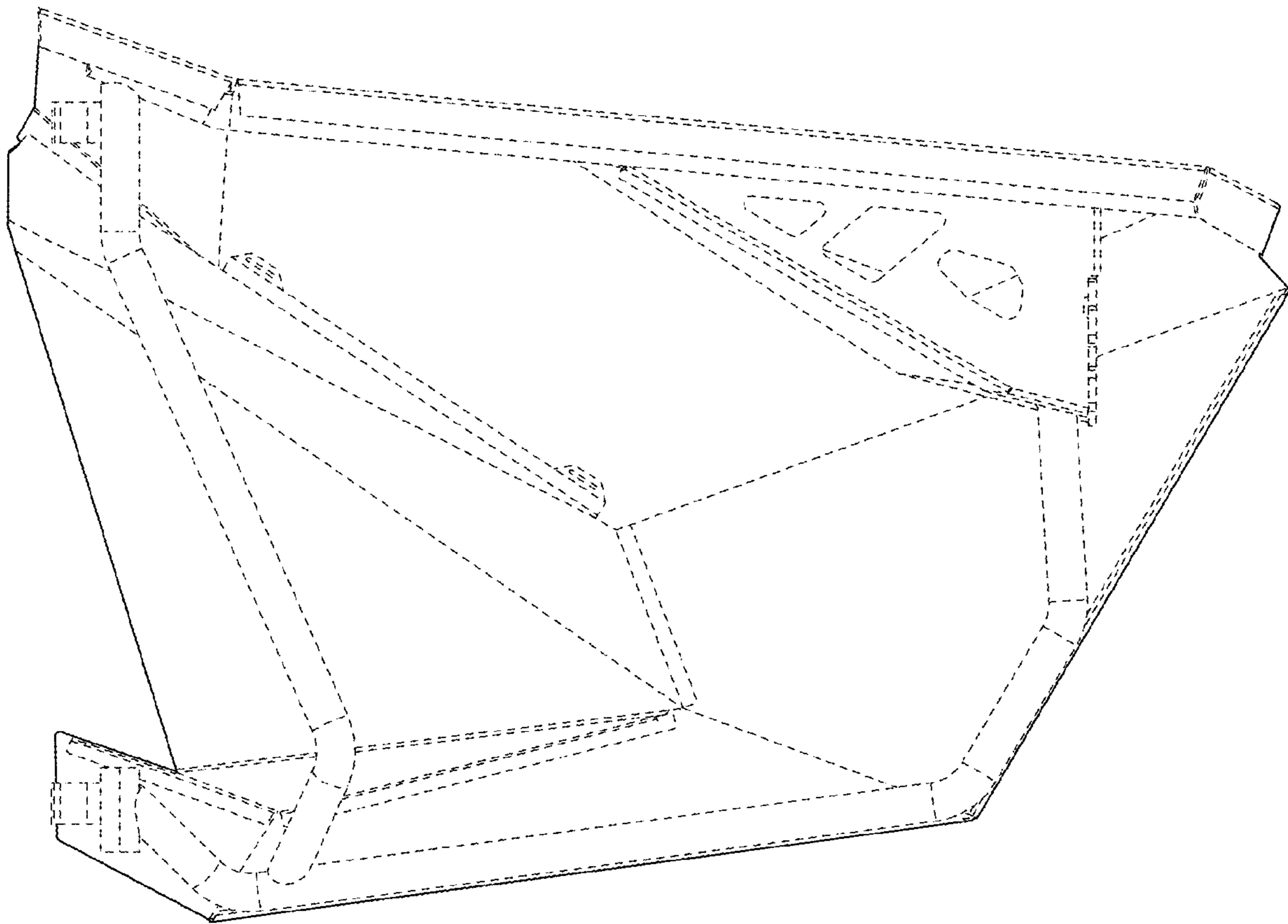

FIG. 4

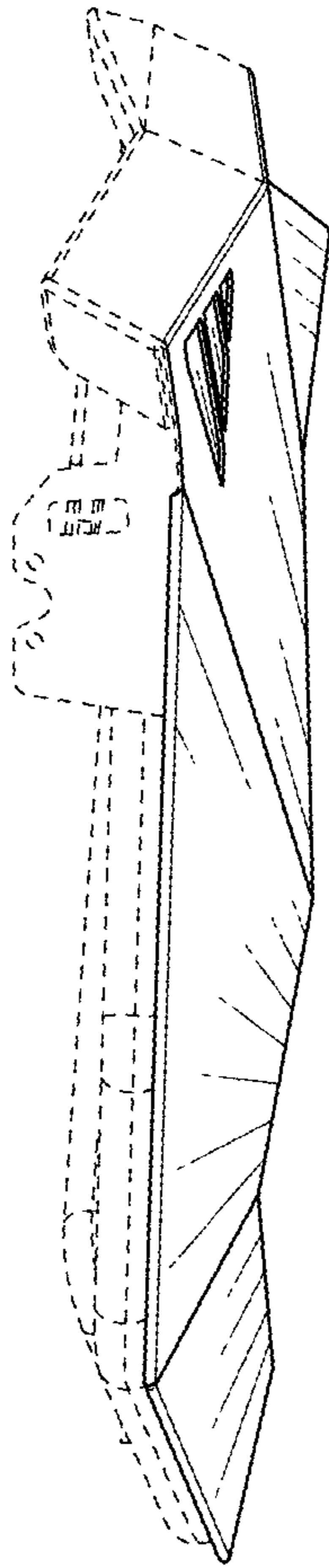

FIG. 5



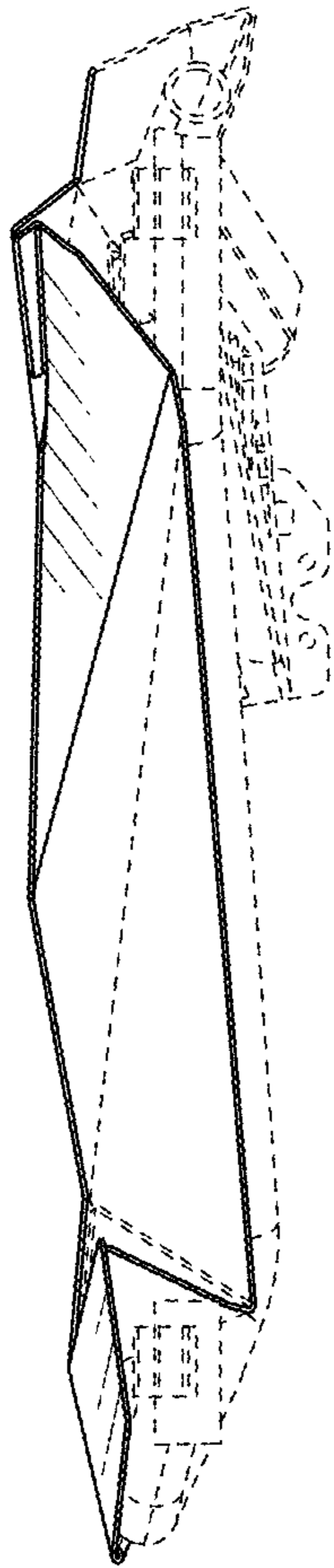

FIG. 6

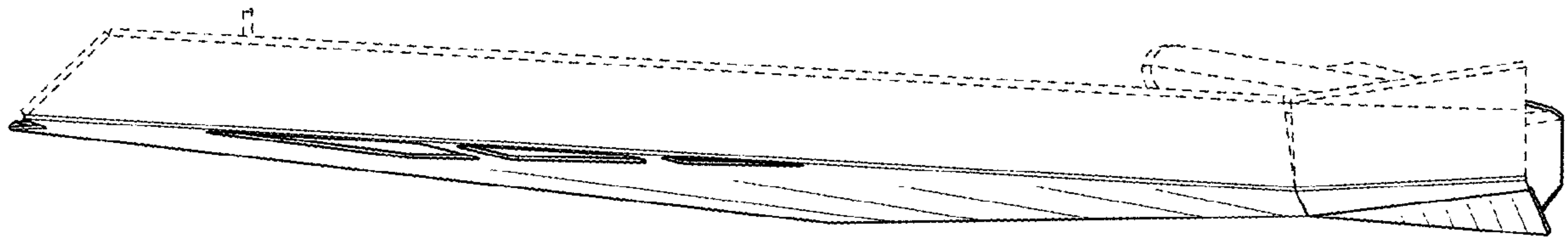

FIG. 7

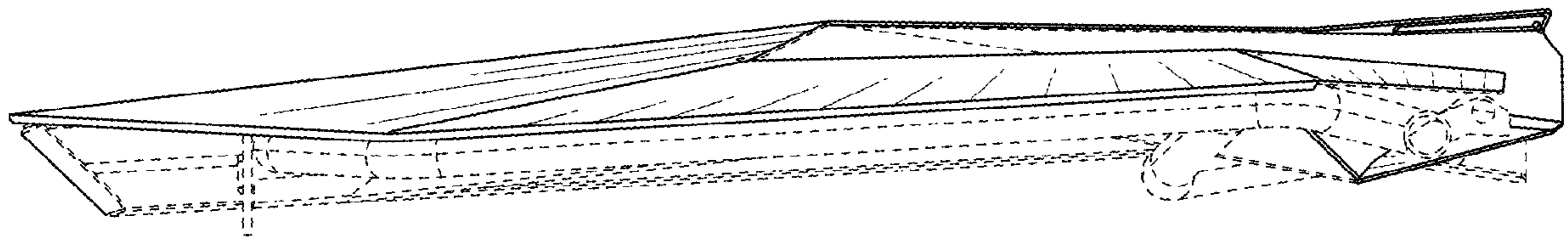

FIG. 8

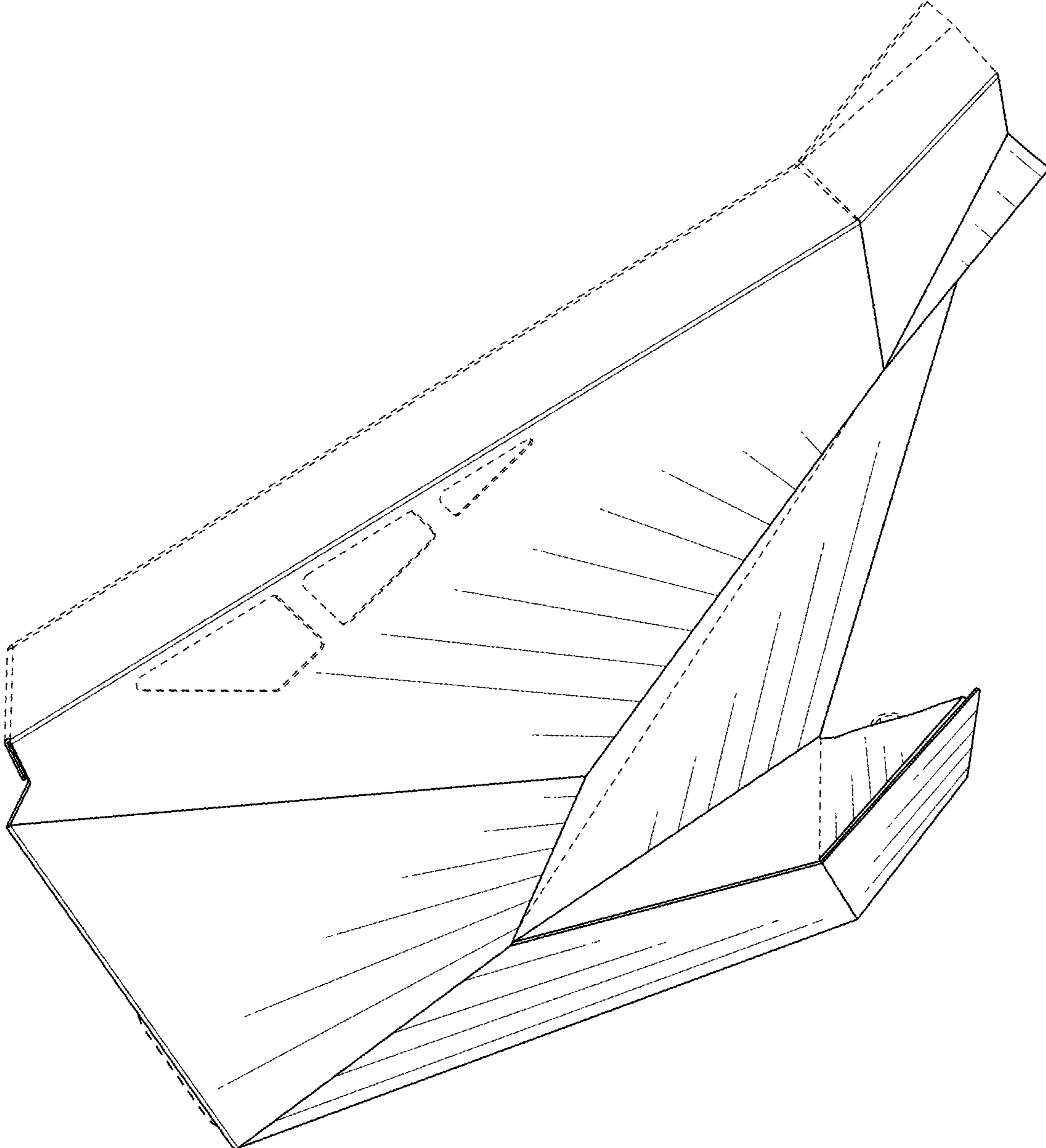

FIG. 9

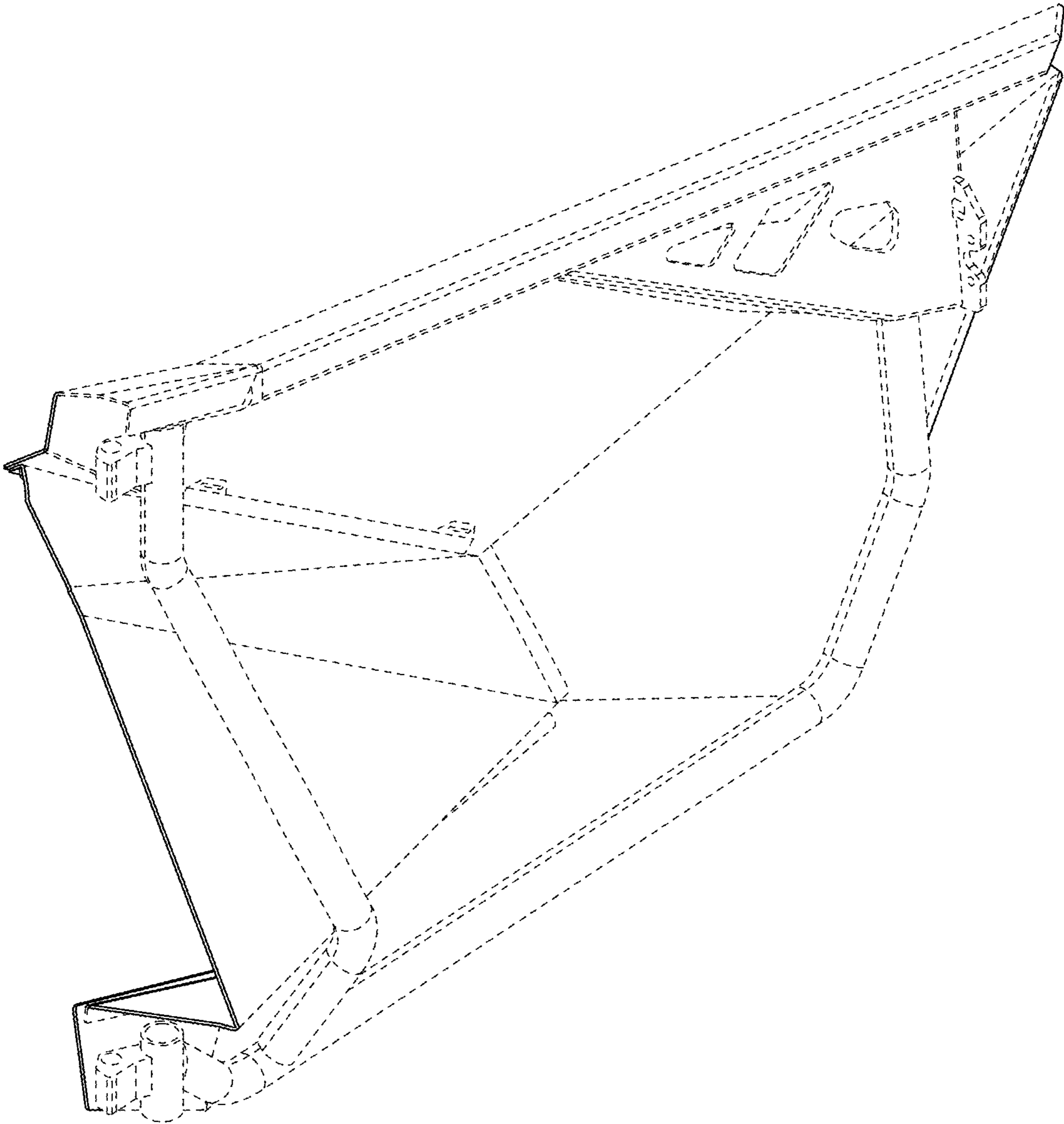

FIG. 10

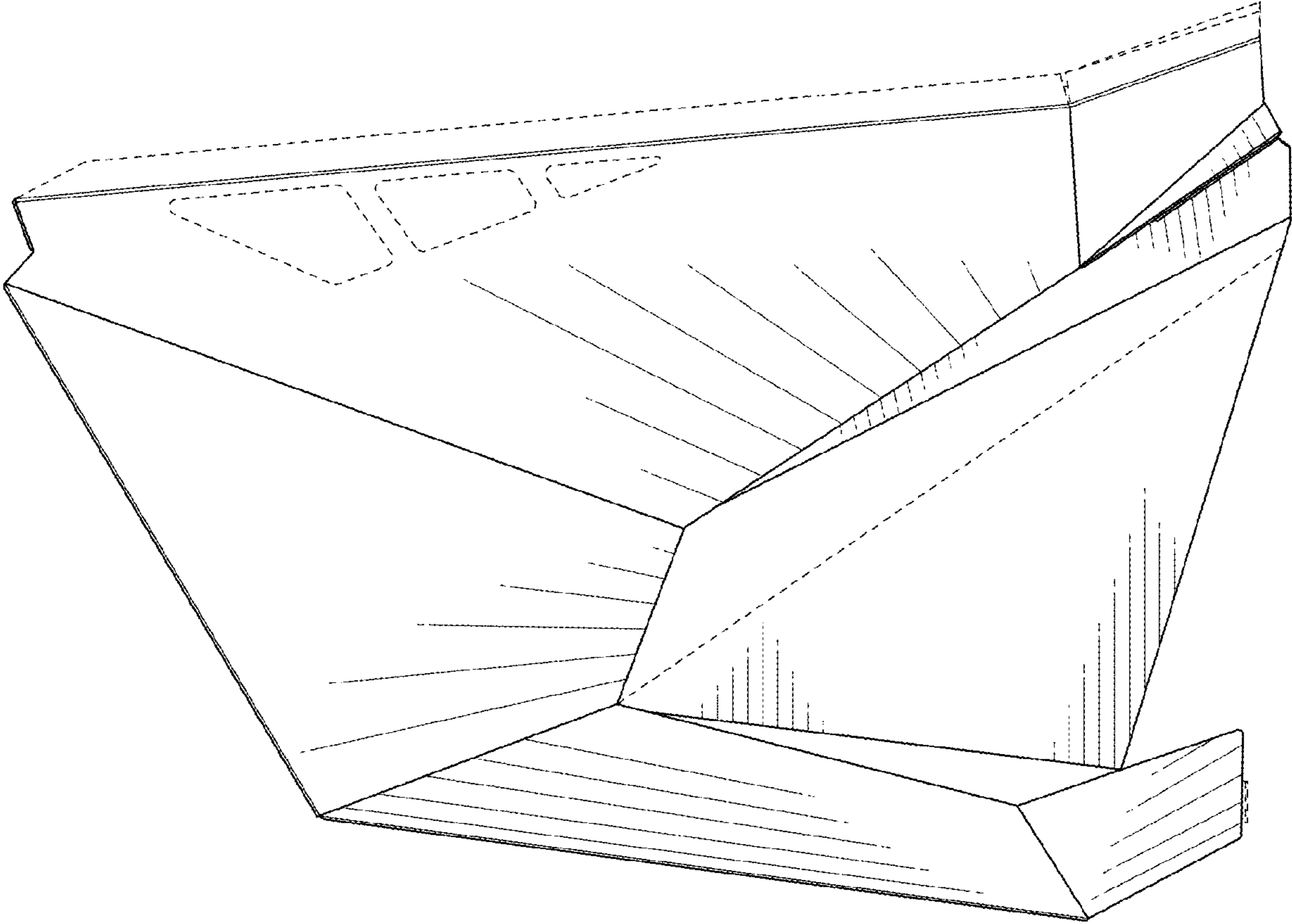

FIG. 11

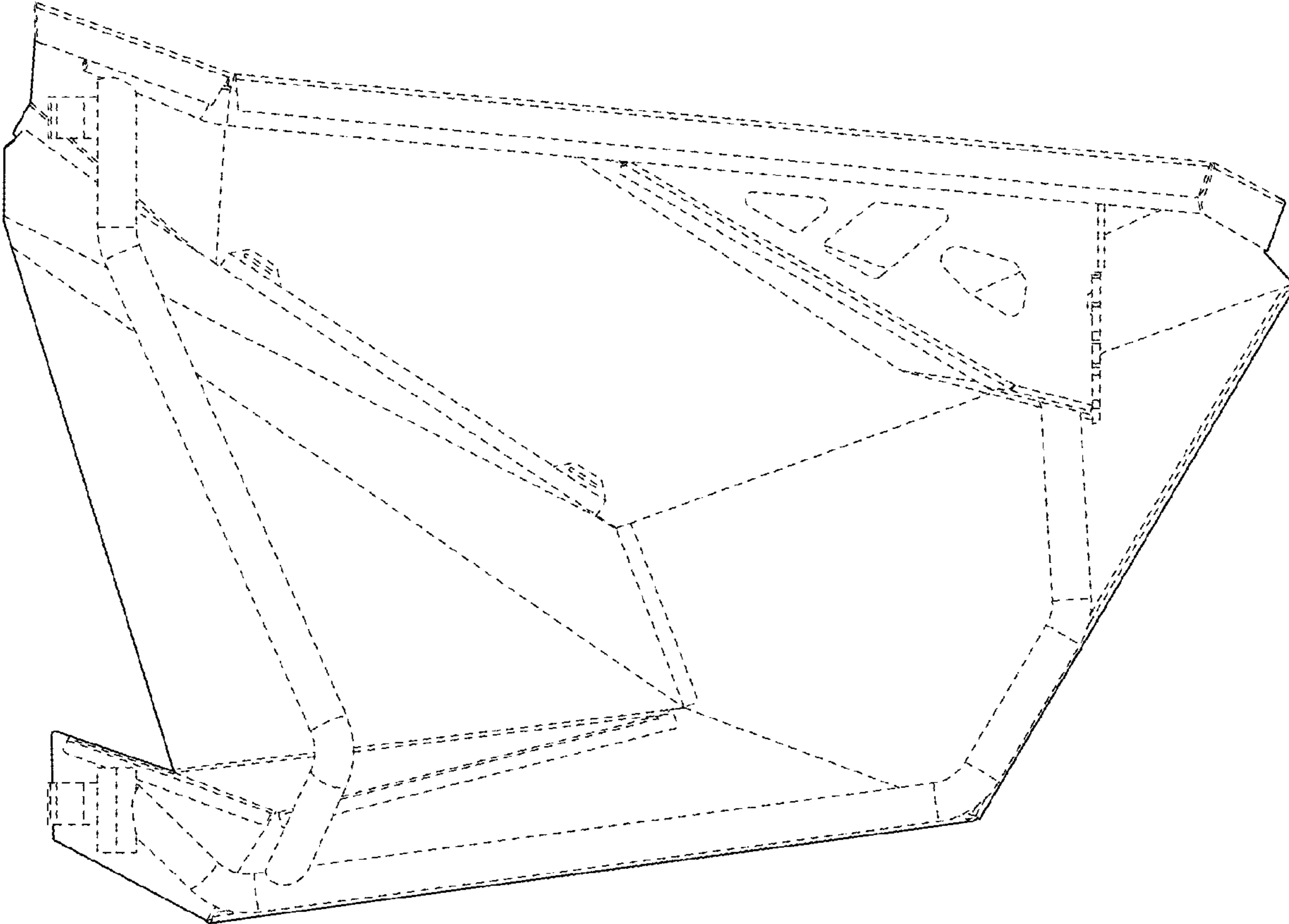

FIG. 12

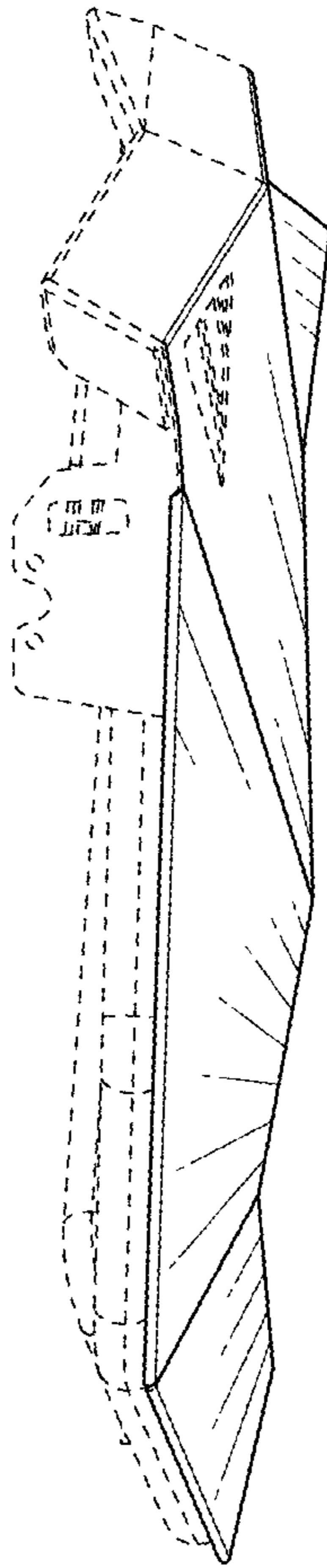

FIG. 13



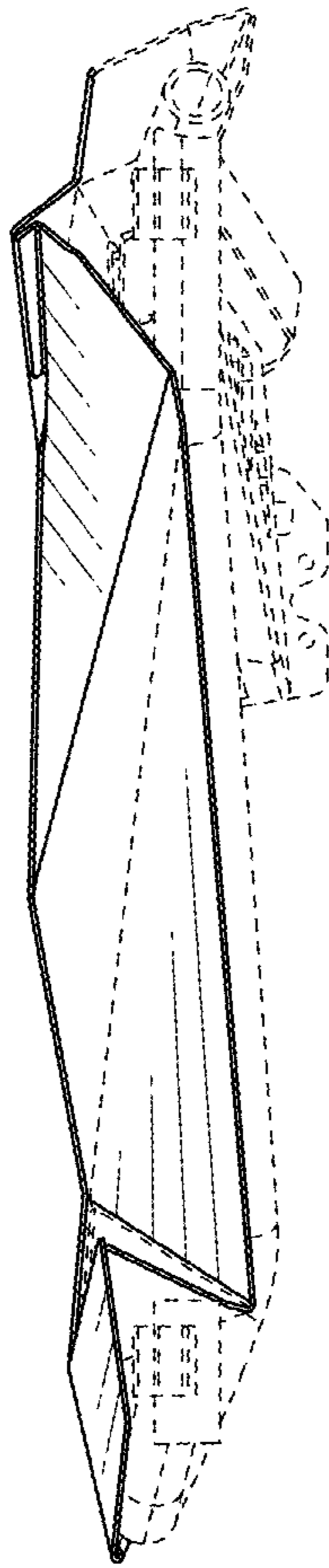

FIG. 14

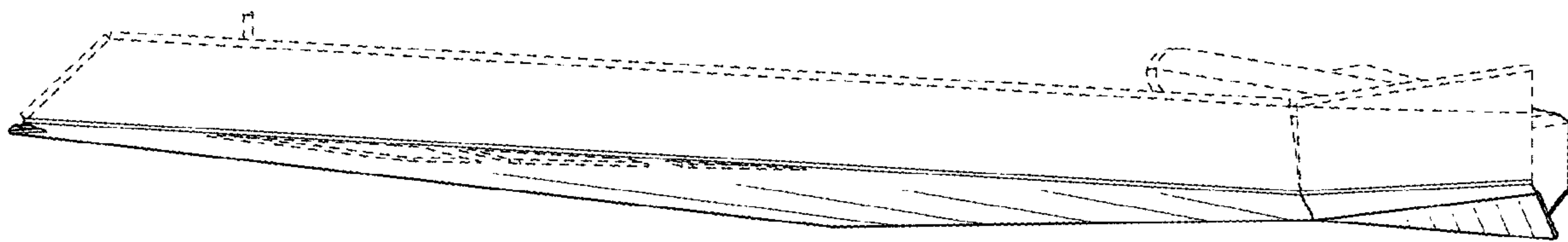

FIG. 15

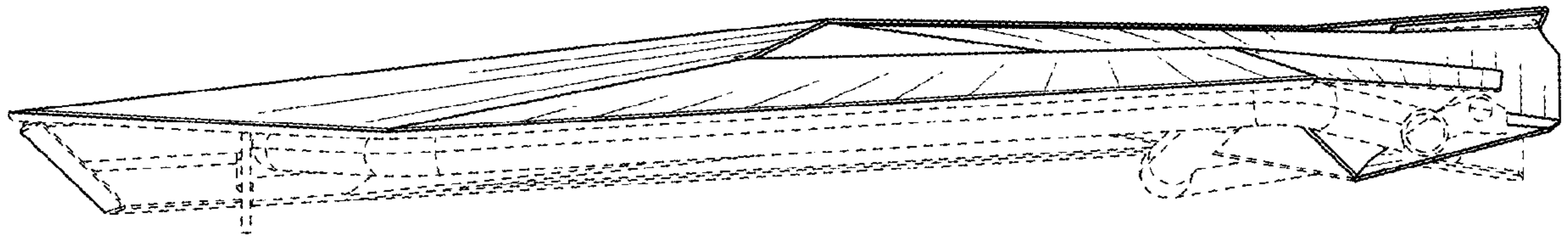

FIG. 16