



US00D955814S

(12) **United States Design Patent**
Kestenbaum

(10) **Patent No.:** **US D955,814 S**
(45) **Date of Patent:** **** Jun. 28, 2022**

(54) **COFFEE MAKER COMPONENT**

FOREIGN PATENT DOCUMENTS

(71) Applicant: **SharkNinja Operating LLC**,
Needham, MA (US)

JP 817686 9/1991
JP 1578234 5/2017

(Continued)

(72) Inventor: **Daniel Kestenbaum**, Brookline, MA
(US)

OTHER PUBLICATIONS

(73) Assignee: **SharkNinja Operating LLC**,
Needham, MA (US)

Ninja Coffee Maker | posted at Amazon.com, posted on Sep. 15,
2016, © 1996-2022 Amazon.com, [online], [site visited Feb. 10,
2022]. Available from Internet, <URL: [https://www.amazon.com/
Ninja-Programmable-Removable-Reservoir-CF091/dp/
B01KA7VWWC/](https://www.amazon.com/Ninja-Programmable-Removable-Reservoir-CF091/dp/B01KA7VWWC/)> (Year: 2016).*

(**) Term: **15 Years**

(Continued)

(21) Appl. No.: **29/758,440**

(22) Filed: **Nov. 16, 2020**

Primary Examiner — Andrew Kerr

Related U.S. Application Data

(74) *Attorney, Agent, or Firm* — Mintz Levin Cohn Ferris
Glovsky and Popeo, PC; Lisa Adams

(62) Division of application No. 29/724,419, filed on Feb.
14, 2020, now Pat. No. Des. 901,969, which is a
division of application No. 29/653,379, filed on Jun.
14, 2018, now Pat. No. Des. 878,846, which is a
division of application No. 29/564,780, filed on May
16, 2016, now Pat. No. Des. 823,036.

(57) **CLAIM**

The ornamental design for a coffee maker component, as
shown and described.

(51) **LOC (13) Cl.** **07-99**

DESCRIPTION

(52) **U.S. Cl.**
USPC **D7/399; D7/412**

(58) **Field of Classification Search**
USPC D7/300, 305, 306, 309–311, 355, 362,
D7/365, 367, 397, 412, 413, 376, 377,
D7/378, 399
CPC A47J 31/46; A47J 31/407; A47J 31/50;
A47J 31/18; A47J 31/00; A47J 31/0573;
A47J 31/52; A47J 27/04

FIG. 1 is a perspective view of a coffee maker component,
showing our new design;
FIG. 2 is a front view thereof;
FIG. 3 is a rear view thereof;
FIG. 4 is side view thereof;
FIG. 5 is another side view thereof;
FIG. 6 is a top view thereof;
FIG. 7 is a bottom view thereof;
FIG. 8 is another perspective view thereof; and,
FIG. 9 is another perspective view thereof.

See application file for complete search history.

The broken lines in the figures are for environmental pur-
poses only and form no part of the claimed design.

The oblique line shading shows a transparent or translucent
surface.

(56) **References Cited**

U.S. PATENT DOCUMENTS

D213,577 S 3/1969 Douglas
D225,365 S 12/1972 Beckman
D245,058 S 7/1977 Hauenstein

(Continued)

1 Claim, 9 Drawing Sheets

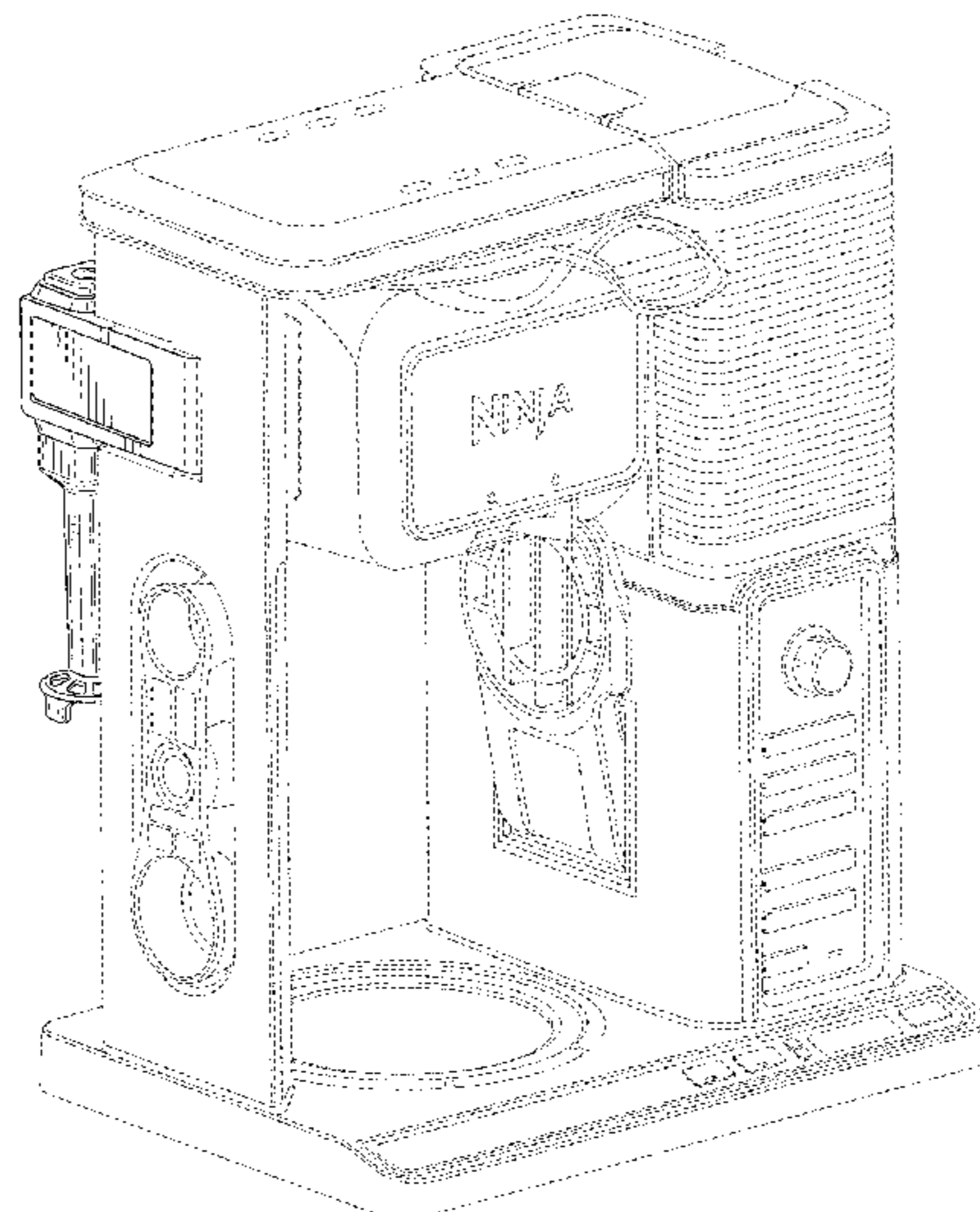

(56)

References Cited

U.S. PATENT DOCUMENTS

4,058,338 A 11/1977 Brown
 D253,572 S 12/1979 Rinaldi
 4,503,757 A 3/1985 Daugherty
 4,590,975 A 5/1986 Credle
 D296,408 S 6/1988 Gaunt et al.
 D308,001 S * 5/1990 Ricard D7/376
 D314,881 S 2/1991 Wondergem et al.
 D317,996 S 7/1991 Jack
 D318,973 S 8/1991 Hasslacher
 D321,806 S 11/1991 Chaney
 D324,319 S 3/1992 Faerber et al.
 D327,601 S 7/1992 Beeren et al.
 D337,915 S 8/1993 Kahlcke
 D348,585 S 7/1994 Sham
 D379,049 S 5/1997 Amiel
 D381,237 S 7/1997 Delonghi
 D381,437 S 7/1997 Browning
 D409,875 S 5/1999 Alonge et al.
 5,931,082 A 8/1999 Kim et al.
 6,148,717 A 11/2000 Lassota
 D452,106 S 12/2001 Seiffert
 D490,639 S 6/2004 Kling
 7,267,476 B2 * 9/2007 Rutigliano B01F 13/002
 366/129
 D558,507 S 1/2008 Picozza et al.
 D562,052 S 2/2008 De Pra'
 D577,244 S * 9/2008 Cahen D7/305
 D581,717 S * 12/2008 Parker D7/309
 D584,912 S 1/2009 Green et al.
 D585,691 S 2/2009 Borin
 D594,688 S 6/2009 Hammad et al.
 D598,693 S 8/2009 Kindler et al.
 D598,695 S 8/2009 Currie
 7,717,026 B1 5/2010 Lassota
 D634,962 S 3/2011 Butler
 D634,963 S 3/2011 Romandy
 D648,973 S 11/2011 De' Longhi
 8,210,095 B2 7/2012 Brezovnik et al.
 D696,890 S 1/2014 Poniedzialek
 D713,668 S 9/2014 Metaxatos et al.
 D727,084 S 4/2015 Dorr et al.
 D730,675 S 6/2015 Williams et al.
 D733,481 S 7/2015 Rousselin
 D742,159 S 11/2015 Doria et al.
 D752,377 S 3/2016 Maitland et al.
 D753,948 S 4/2016 Kestenbaum
 D756,696 S 5/2016 Murphy et al.
 D765,454 S 9/2016 Romandy
 D770,831 S 11/2016 Affatato et al.
 D770,832 S 11/2016 Affatato et al.
 D771,992 S 11/2016 Yang
 D778,098 S 2/2017 Horimoto
 D782,242 S 3/2017 Lee
 D787,251 S 5/2017 Kestenbaum
 D789,725 S 6/2017 Kestenbaum
 D792,731 S 7/2017 Palermo et al.
 D801,506 S 10/2017 Sevy
 D802,978 S 11/2017 Kestenbaum
 D803,611 S 11/2017 Hanneson et al.
 D814,222 S 4/2018 Bronwasser
 D815,904 S 4/2018 Lane
 D823,035 S 7/2018 Ricica
 D823,036 S 7/2018 Kestenbaum
 D823,628 S 7/2018 Steiner
 D833,792 S 11/2018 Garman
 D834,870 S 12/2018 Steiner
 D853,770 S 7/2019 Koury et al.
 D854,363 S 7/2019 Behrmann
 D878,846 S 3/2020 Kestenbaum
 D879,535 S 3/2020 Ricica
 D906,750 S * 1/2021 Kestenbaum D7/309
 D925,272 S * 7/2021 McConnell D7/380
 D930,424 S * 9/2021 Bourgeois D7/378
 2004/0112224 A1 6/2004 Drobeck
 2005/0166765 A1 8/2005 Llyall, III

2009/0255408 A1 10/2009 Lassota et al.
 2010/0107885 A1 5/2010 Kirschner et al.
 2015/0190011 A1 7/2015 Minard
 2016/0338541 A1* 11/2016 Saunders A47J 43/044
 2016/0360919 A1 12/2016 Burrows
 2017/0156539 A1 6/2017 Han et al.
 2017/0367518 A1 12/2017 Anthony et al.
 2018/0098658 A1 4/2018 Angell et al.
 2019/0045968 A1 2/2019 Hartmann et al.
 2019/0387920 A1 12/2019 Anthony et al.

FOREIGN PATENT DOCUMENTS

JP 1578238 5/2017
 WO 2013098777 A1 7/2013
 WO 2014028844 A1 2/2014
 WO 2016164796 A1 10/2016
 WO 2019067595 A1 4/2019

OTHER PUBLICATIONS

Notice of Allowance; U.S. Appl. No. 29/564,780, filed May 16, 2016; Coffee Maker; dated Mar. 21, 2018; 11 Pages.
 Preliminary Rejection; Korean Application No. 30-2016-0053885; dated Jul. 4, 2017; 5 Pages.
 Requirement for Restriction/Election; U.S. Appl. No. 29/564,776, filed May 16, 2016; Coffee Maker and Components Thereof; dated Dec. 7, 2017; 18 Pages.
 Requirement for Restriction/Election; U.S. Appl. No. 29/564,780, filed May 16, 2016; Coffee Maker and Components Thereof; dated Dec. 7, 2017; 18 Pages.
 U.S. Appl. No. 29/622,046, filed Oct. 13, 2017; Notice of Allowance dated Oct. 25, 2018; 6 pages.
 U.S. Appl. No. 29/680,943, filed Feb. 21, 2019; Restriction Requirement dated May 1, 2020; 16 pages.
 U.S. Appl. No. 29/649,476, filed May 30, 2018; Restriction Requirement dated Jan. 16, 2020; 8 pages.
 U.S. Appl. No. 29/649,476, filed May 30, 2018; Restriction Requirement dated Dec. 19, 2019; 7 pages.
 U.S. Appl. No. 29/649,477, filed May 30, 2018; Restriction Requirement dated Dec. 19, 2019; 7 pages.
 U.S. Appl. No. 29/653,369, filed Jun. 14, 2018; Restriction Requirement dated Jul. 18, 2019; 19 pages.
 U.S. Appl. No. 29/653,379, filed Jun. 14, 2018; Restriction Requirement dated Jul. 18, 2019; 19 pages.
 Written Opinion for International Application No. PCT/US2019/038269; dated Nov. 25, 2019; International Filing Date: Jun. 20, 2019; 11 pages.
 Amazon.com, Inc., "SharkNinja CF092 PowerDoF CM6626T 12-Cup Glass Carafe Programmable Coffee Maker, Small, Black/Stainless Steel," retrieved from Internet Jan. 24, 2020, (JPO Publicly Known Design No. HJ28047009), 8 pages.
 Amazon.com; "SharkNinja PowerDoF CM6626T 12-Cup Glass Carafe Programmable Coffee Maker, Small, Black/Stainless Steel"; Nov. 11, 2016; pp. 1-11; https://www.amazon.com/gp/product/b01ka7vwpy/ref=zg_bsnr_289745_1?ie=utf8&psc=1&refrid=nry9kbp5b5nrh7e6dp8n.
 Application for Registration of an Industrial Design Examiner's Report; Canadian Application No. 171623; dated Nov. 14, 2017; 2 Pages.
 Application for Registration of an Industrial Design Examiner's Report; Canadian Application No. 171623; dated Feb. 17, 2017; 1 Page.
 Application for Registration of an Industrial Design Examiner's Report; Canadian Application No. 171623; dated Jul. 25, 2017; 1 Page.
 Decision to Dismiss the Amendment; Korean Application No. 30-2016-0053885; Date of Mailing: Jul. 6, 2017; 5 Pages.
 Hammacher Schlemmer, "The Four Specific Brew Barista Machine," 89861, retrieved from Internet Jan. 24, 2020, (JPO Publicly Known Design No. HJ28041235), 3 pages.

(56)

References Cited

OTHER PUBLICATIONS

International Search Report for International Application No. PCT/US2019/038269; dated Nov. 25, 2019; International Filing Date: Jun. 20, 2019; 7 pages.

Invitation to Pay Additional Fees for International Application No. PCT/US2019/038269; International Filing Date Mar. 20, 2019; dated Sep. 27, 2019; 197 pages.

Japanese Design Application No. 201826036 filed Nov. 30, 2018; Notice of Allowance dated Nov. 8, 2019; 6 pages.

Japanese Design Application No. 201826037 filed Nov. 30, 2018; Notice of Allowance dated Nov. 8, 2019; 6 pages.

Japanese Patent Application No. 2019018140 filed Aug. 16, 2019; Office Action dated May 11, 2020; 6 pages.

Korean Design and Trademark Gazette, vol. 795, (Aug. 23, 1989), p. 40, 93797, (JPO Publicly Known Design No. HH02008182), 4 pages.

Preliminary Rejection; Korean Application No. 30-2016-0053882; dated Jul. 4, 2017; 5 Pages.

Non-Final Office Action; U.S. Appl. No. 29/564,778, filed May 16, 2016; Carafe; dated Mar. 10, 2017; 9 Pages.

Non-Final Office Action; U.S. Appl. No. 29/622,046, filed Oct. 13, 2017; Carafe; dated Jun. 5, 2018; 20 Pages.

Notice of Allowance; Japanese Design Application No. 2016-024849; dated Mar. 31, 2017; 2 Pages.

Notice of Allowance; Japanese Design Application No. 2016-024850; dated Mar. 31, 2017; 2 Pages.

Notice of Allowance; Japanese Design Application No. 2016-024851; dated Mar. 31, 2017; 2 Pages.

Notice of Allowance; Japanese Design Application No. 2016-024852; dated Mar. 31, 2017; 2 Pages.

Notice of Allowance; Japanese Design Application No. 2016-024853; dated Mar. 31, 2017; 2 Pages.

Notice of Allowance; Japanese Design Application No. 2016-024854; dated Mar. 31, 2017; 2 Pages.

Notice of Allowance; Japanese Design Application No. 2016-024855; dated Mar. 31, 2017; 2 Pages.

Notice of Allowance; U.S. Appl. No. 29/564,776, filed May 16, 2016; Coffee Maker; dated Mar. 21, 2018; 11 Pages.

Notice of Allowance; U.S. Appl. No. 29/564,778, filed May 16, 2016; Carafe; dated Jul. 13, 2017; 10 Pages.

Notice of Allowance; U.S. Appl. No. 29/564,780, filed May 16, 2016; Coffee Maker; dated Mar. 21, 2018; 11 Pages.

Notice of Completion of Formalities for Patent Register and Notice of Grant of Design Patent Right; Chinese Application No. 2016305567649; dated Jan. 19, 2017; 5 Pages.

Notice of Completion of Formalities for Patent Register and Notice of Grant of Design Patent Right; Chinese Application No. 2016305570459; dated Jan. 19, 2017; 5 Pages.

Notice of Completion of Formalities for Patent Register and Notice of Grant of Design Patent Right; Chinese Application No. 201630557068X; dated Jan. 19, 2017; 5 Pages.

Notice of Completion of Formalities for Patent Register and Notice of Grant of Design Patent Right; Chinese Application No. 2016305573207; dated Jan. 17, 2017; 5 Pages.

Notice of References; Japanese Design Application No. 2016-024849; dated Mar. 31, 2017; 2 Pages.

Notice of References; Japanese Design Application No. 2016-024850; dated Mar. 31, 2017; 2 Pages.

Philips, "1/91Elektro-Hausgera TE-Programm," HD5860, p. 23, dated Nov. 28, 1991, (JPO Publicly Known Design No. HD04000894), 5 pages.

Preliminary Rejection; Korean Application No. 30-2016-0053875; dated Jul. 4, 2017; 3 Pages.

Preliminary Rejection; Korean Application No. 30-2016-0053876; dated Oct. 14, 2017; 7 Pages.

Preliminary Rejection; Korean Application No. 30-2016-0053877; dated Jul. 4, 2017; 4 Pages.

Preliminary Rejection; Korean Application No. 30-2016-0053878; dated Jul. 4, 2017; 2 Pages.

Preliminary Rejection; Korean Application No. 30-2016-0053879; dated Jul. 4, 2017; 5 Pages.

Spruce Eats: Tea Brewing Times and Temperature. 2017. <https://www.thespruceeats.com/tea-brewing-times-and-temperatures-1328730>.

U.S. Appl. No. 16/444,827, filed Jun. 18, 2019; Non-Final Office Action dated Jan. 22, 2021; 44 pages.

* cited by examiner

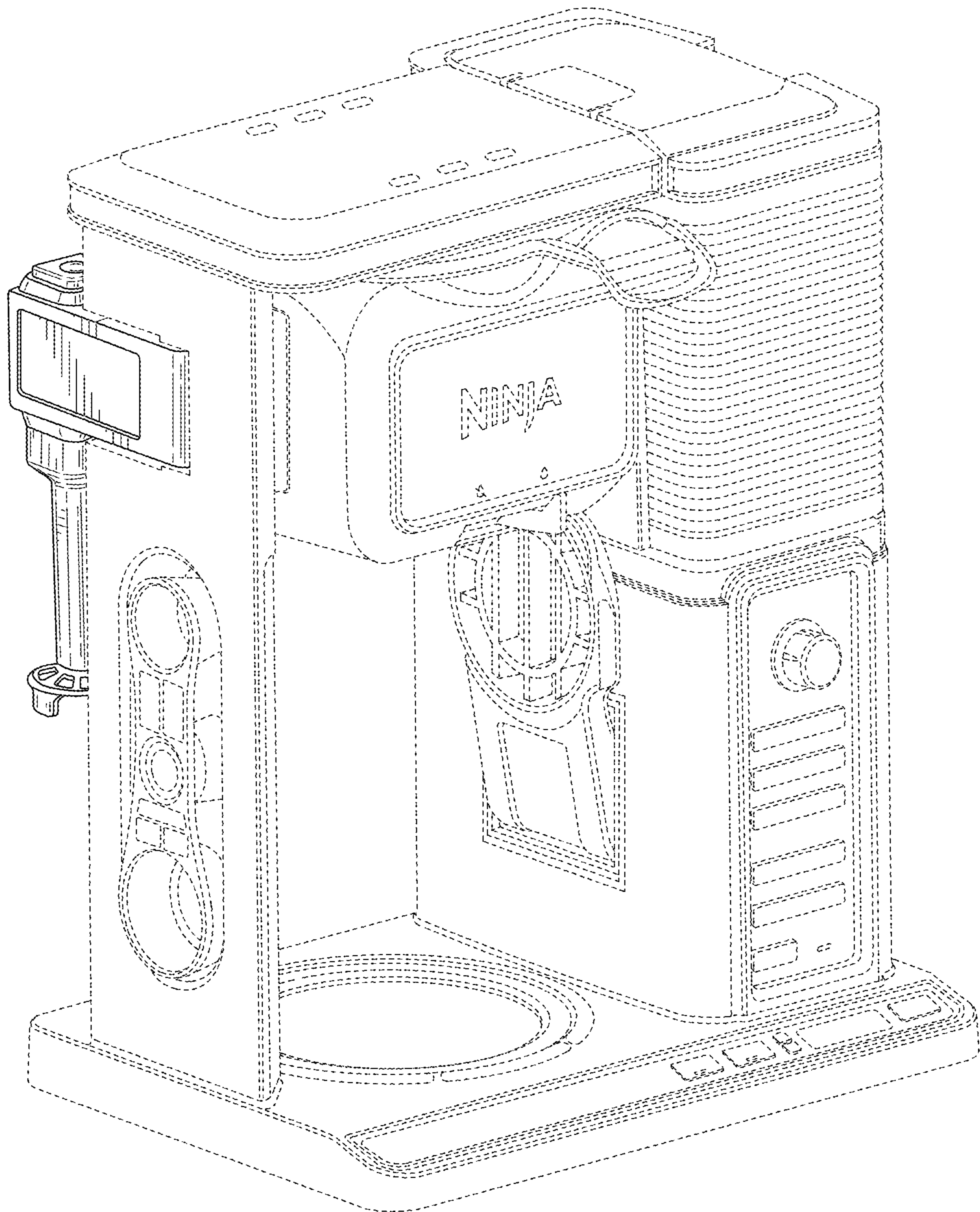

FIG. 1

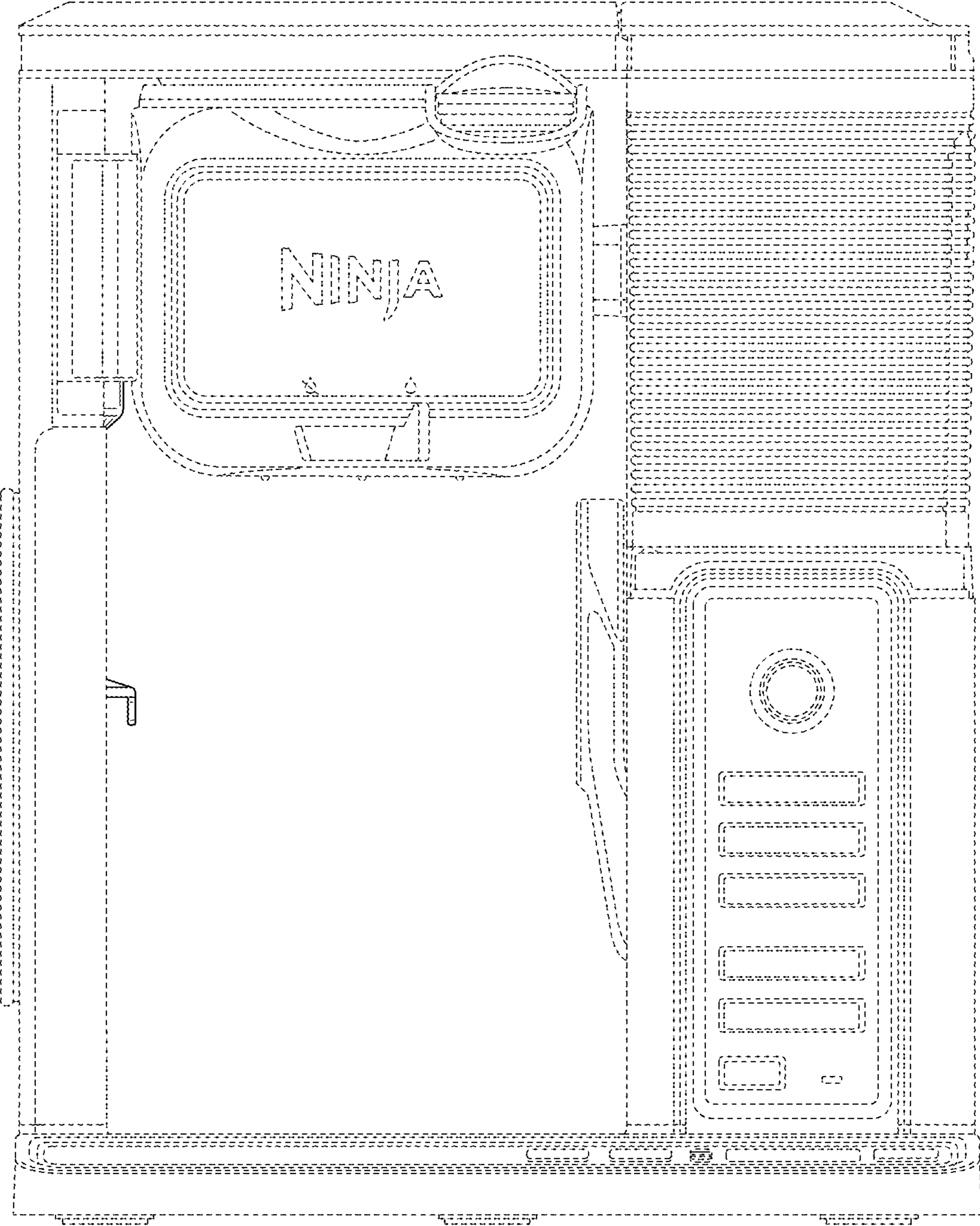

FIG. 2

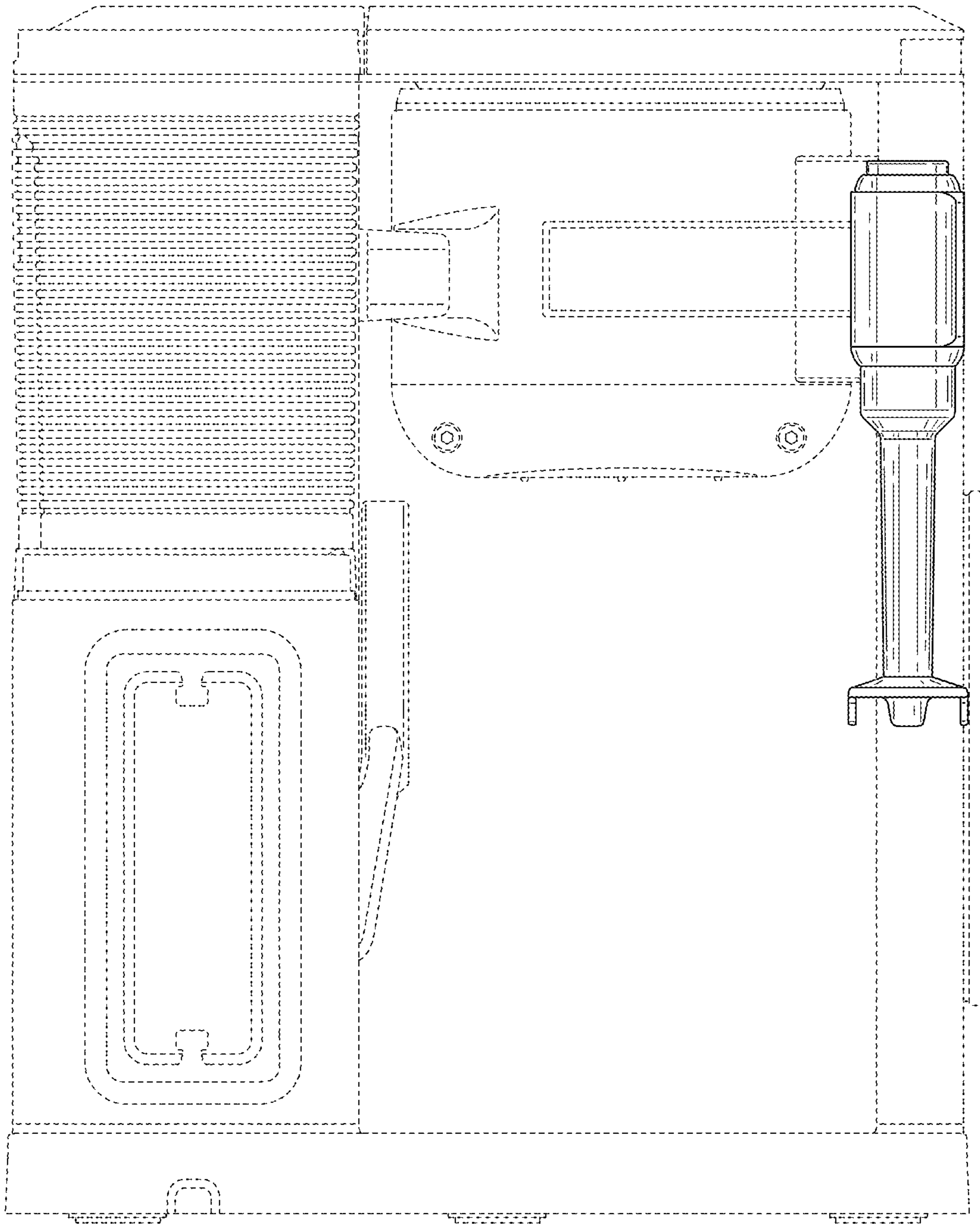

FIG. 3

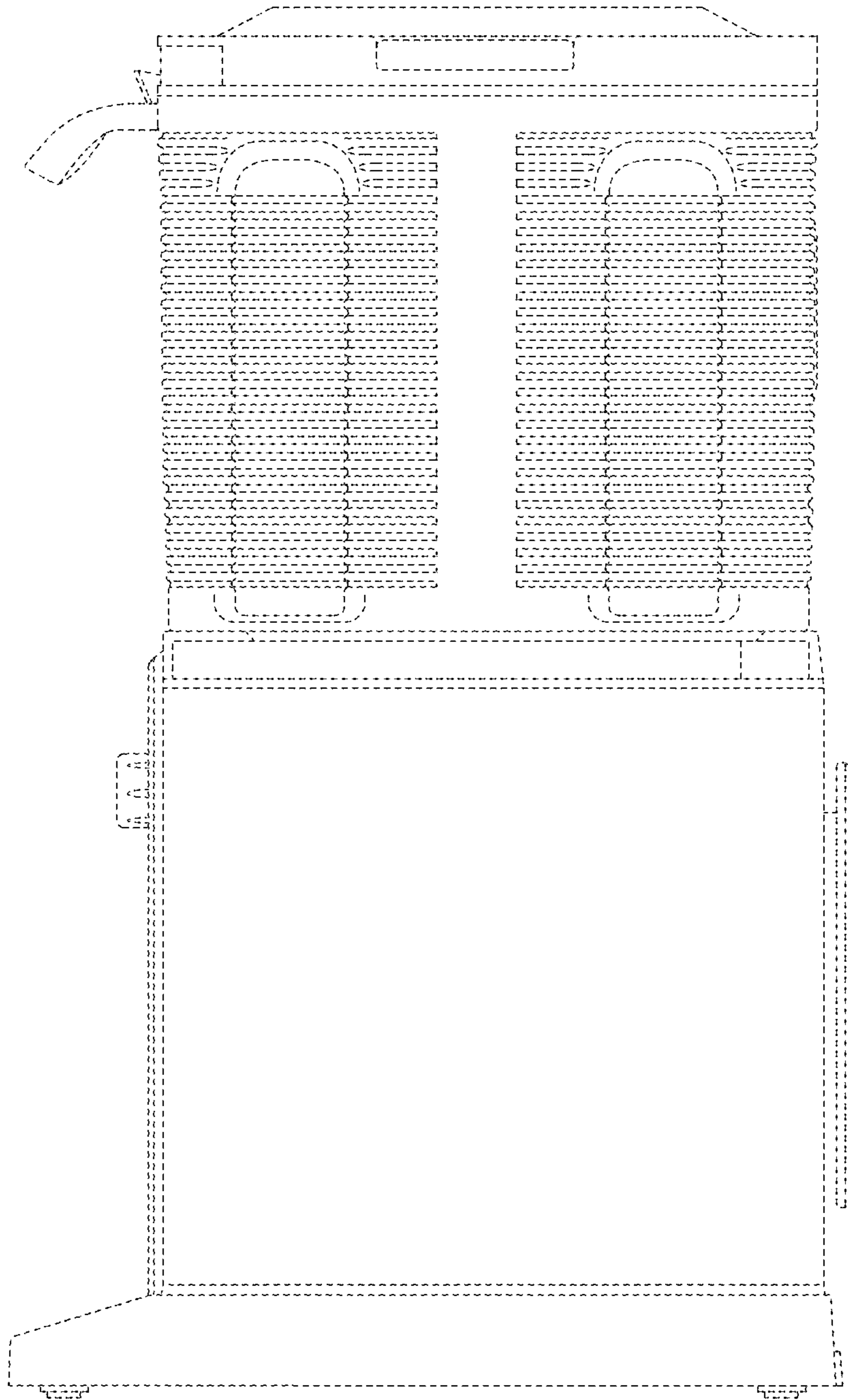

FIG. 4

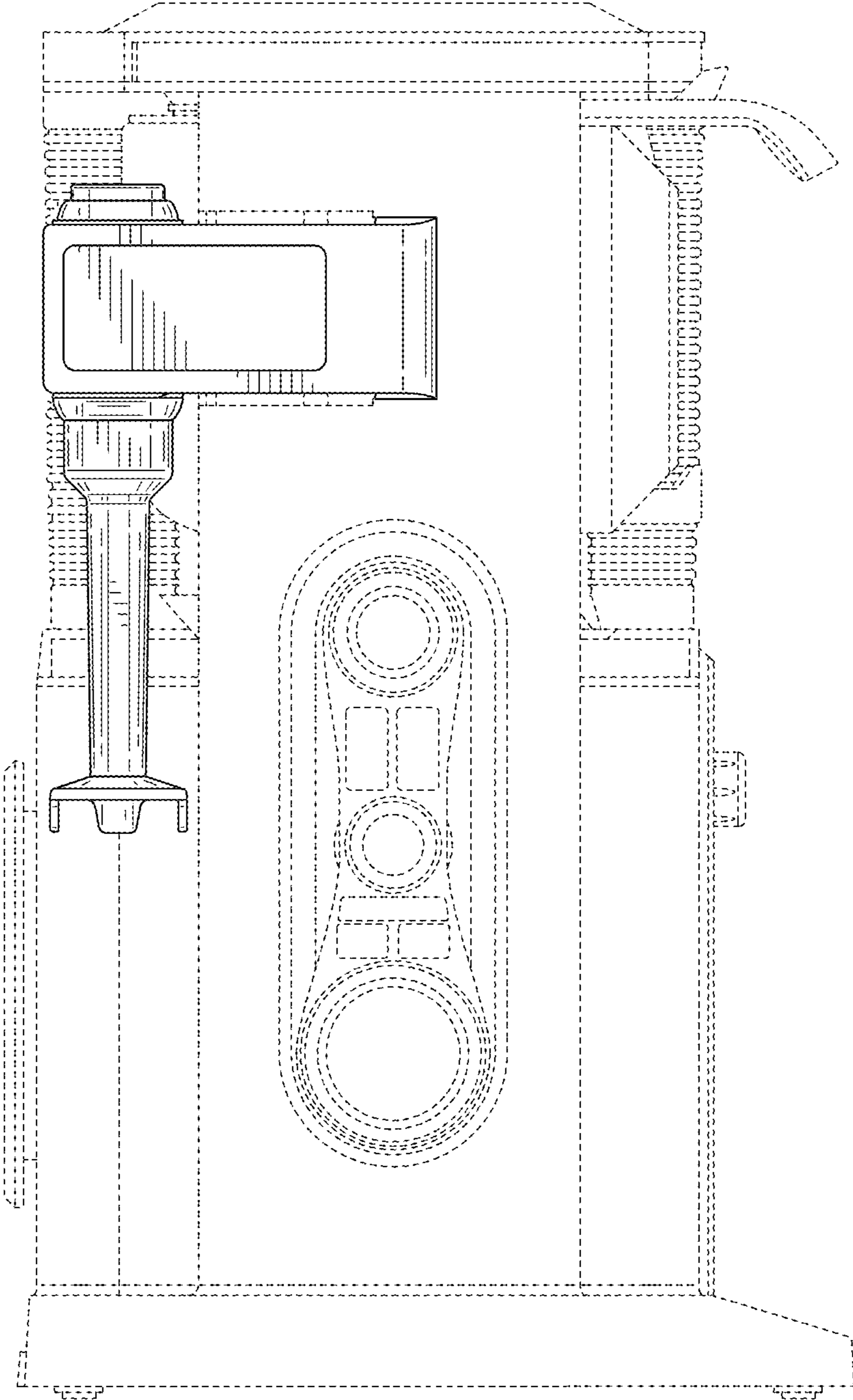

FIG. 5

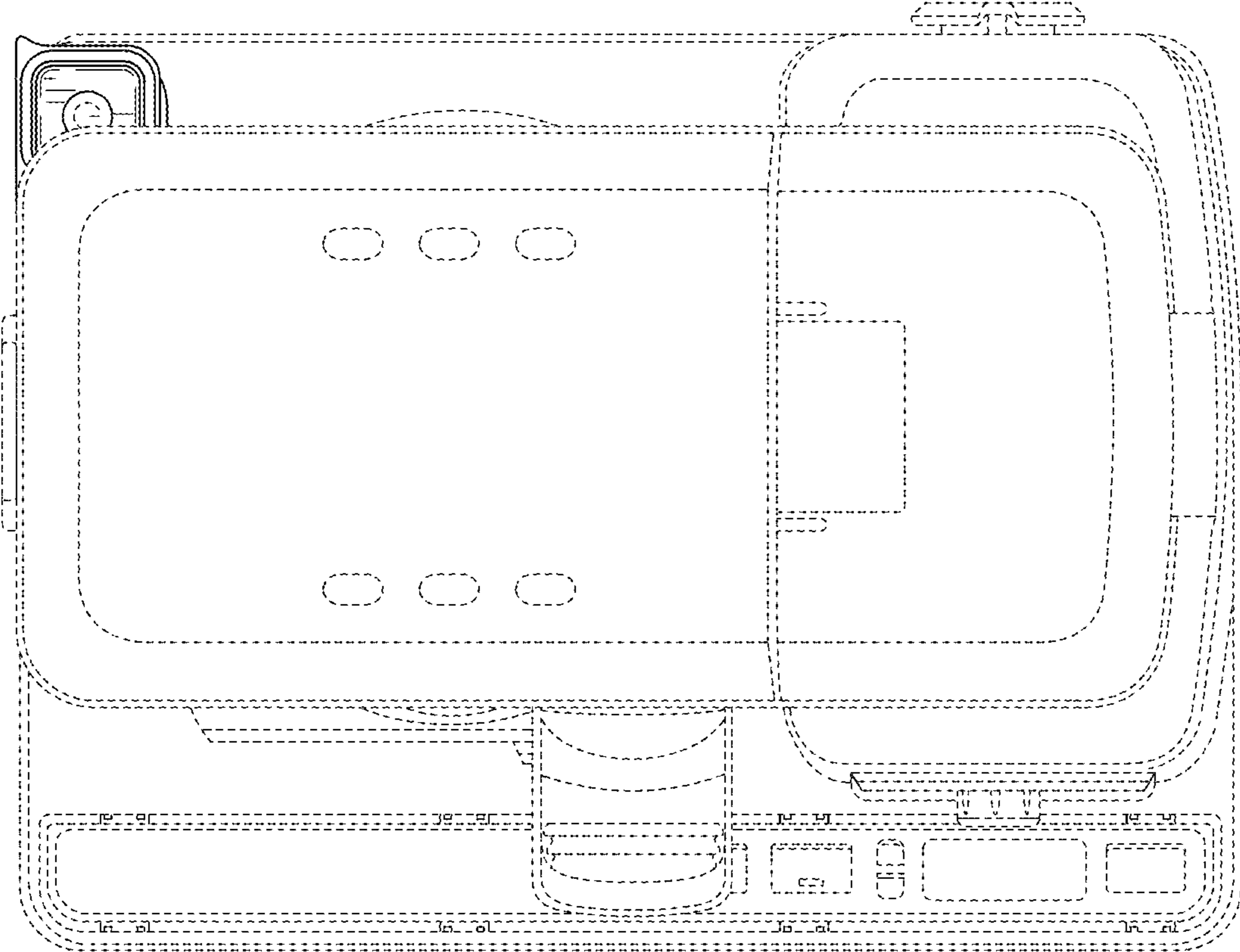

FIG. 6

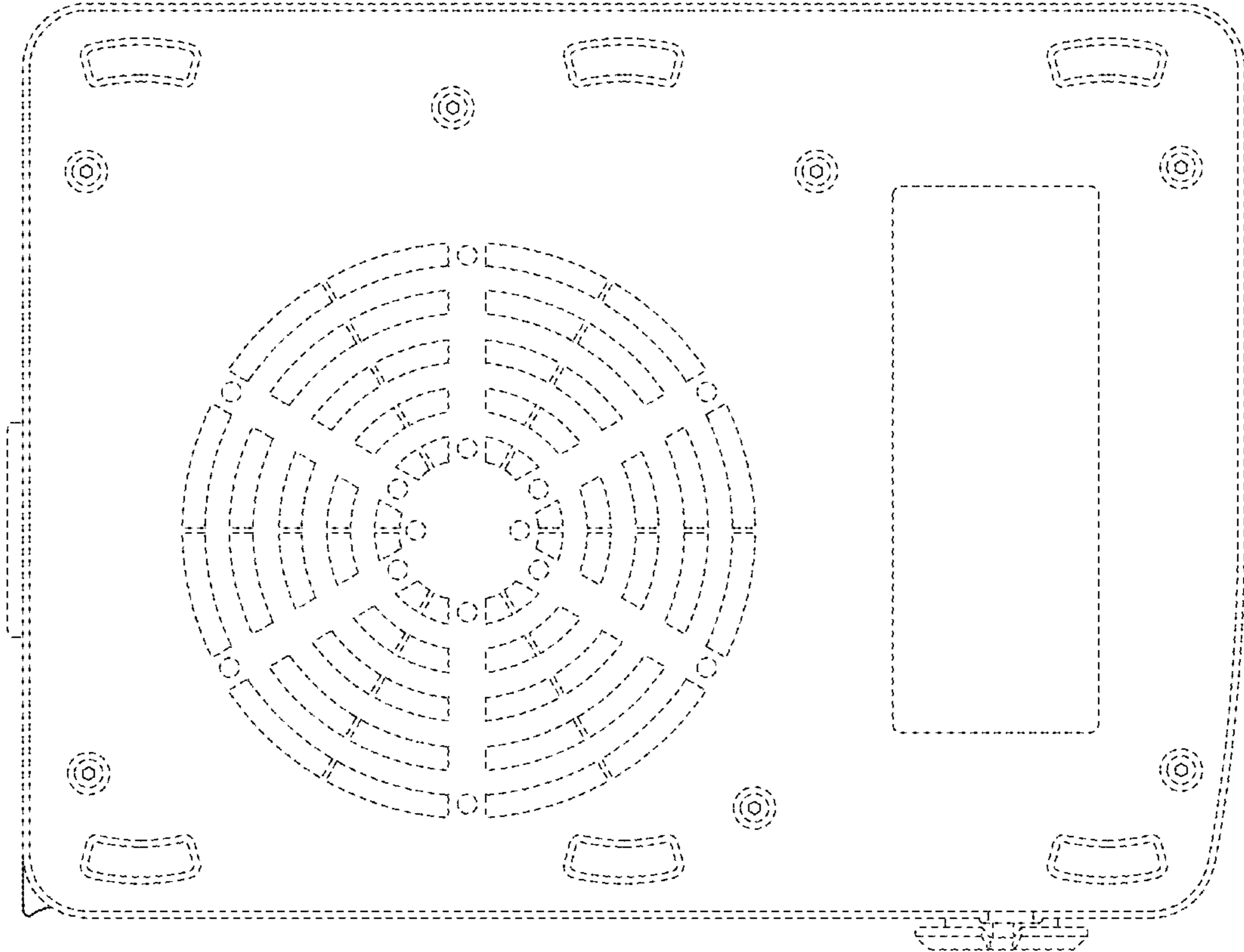

FIG. 7

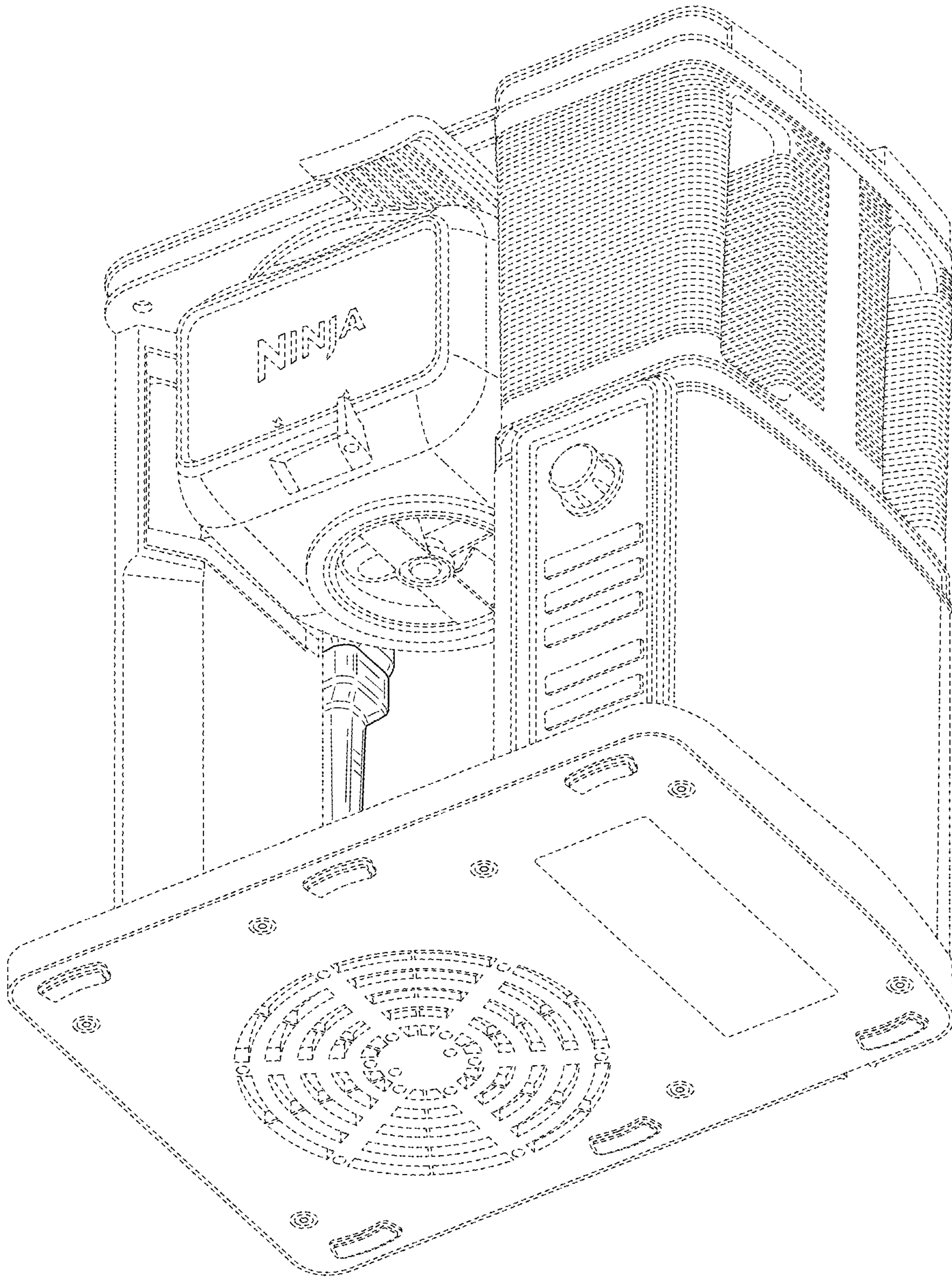

FIG. 8

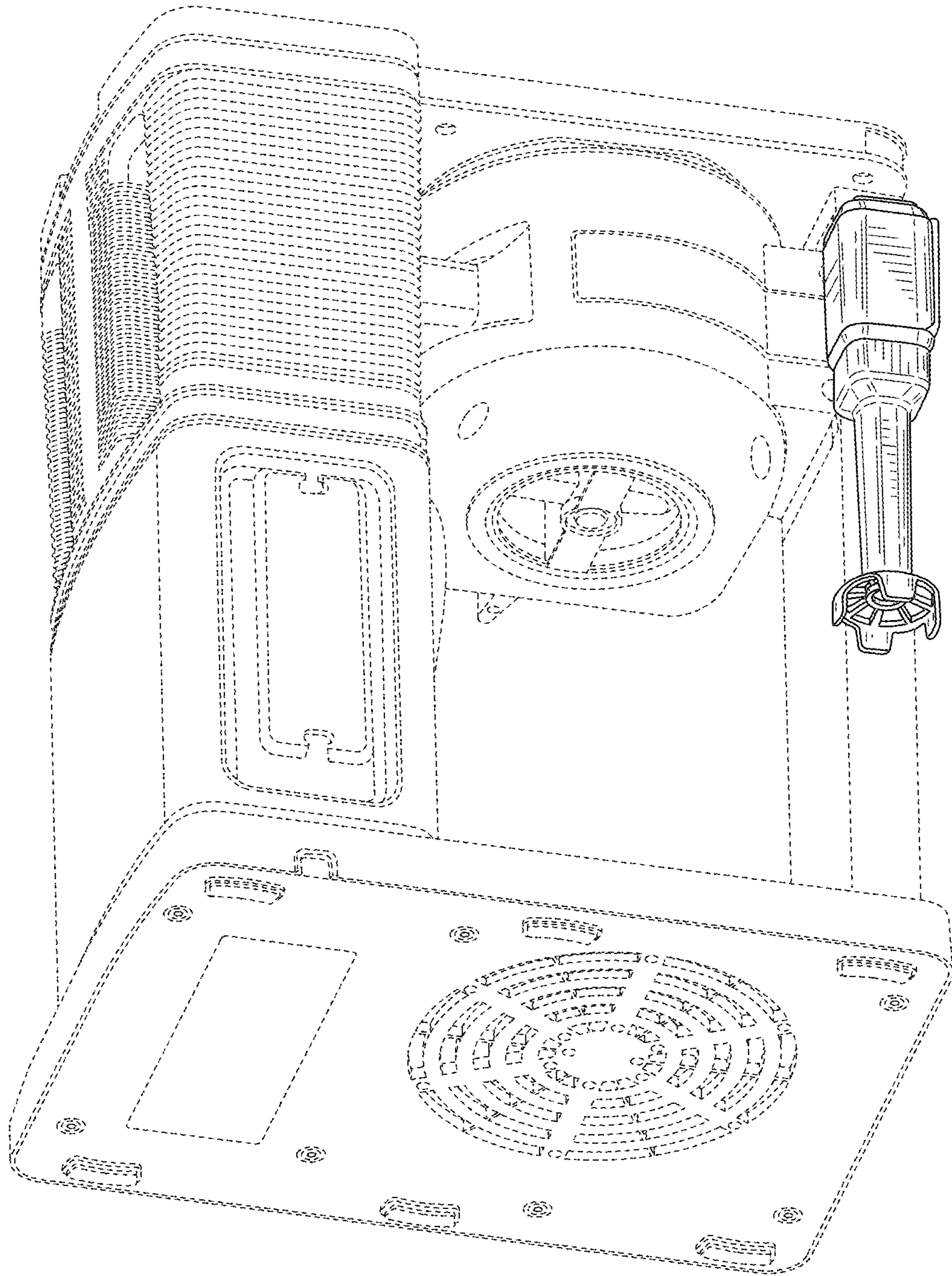

FIG. 9