



US00D955611S

(12) **United States Design Patent**
Ye

(10) **Patent No.:** **US D955,611 S**
(45) **Date of Patent:** **** Jun. 21, 2022**

(54) **DAILY LIGHT FOR A GOLF CART**

D390,979 S * 2/1998 Yamamoto D26/28
D874,039 S * 1/2020 He D26/28
D921,945 S * 6/2021 Lin D26/28
D929,622 S * 8/2021 Wu D26/28

(71) Applicant: **Chongqing Richland Mold Corp.,**
Chongqing (CN)

* cited by examiner

(72) Inventor: **Lin Ye,** Chongqing (CN)

Primary Examiner — Marcus A Jackson

(73) Assignee: **CHONGQING RICHLAND MOLD**
CORP., Chongqing (CN)

(74) *Attorney, Agent, or Firm* — Cheng-Ju Chiang

(**) Term: **15 Years**

(57) **CLAIM**

(21) Appl. No.: **29/697,727**

The ornamental design for a daily light for a golf cart, as shown and described.

(22) Filed: **Jul. 10, 2019**

(51) **LOC (13) Cl.** **26-06**

(52) **U.S. Cl.**
USPC **D26/28**

DESCRIPTION

(58) **Field of Classification Search**
USPC D26/28-36, 1
CPC F21S 48/00; F21S 48/10; F21S 48/115;
F21S 48/225; F21S 48/1233; F21S
48/1266; F21S 48/1388; F21S 48/2268;
F21V 5/00; B60Q 9/13; B60Q 9/135;
B60Q 9/1375

FIG. 1 is a front, left and bottom perspective view of a daily light for a golf cart showing my new design;
FIG. 2 is a rear, right and top perspective view thereof;
FIG. 3 is a front elevational view thereof;
FIG. 4 is a back elevational view thereof;
FIG. 5 is a left side elevational view thereof;
FIG. 6 is a right side elevational view thereof;
FIG. 7 is a top plan view thereof; and,
FIG. 8 is a bottom plan view thereof.

See application file for complete search history.

The broken line portion of the drawings is included to show unclaimed subject matter only and forms no part of the claimed design.

(56) **References Cited**

U.S. PATENT DOCUMENTS

D354,362 S * 1/1995 Tsai D26/28
D357,329 S * 4/1995 Iacovelli D26/28

1 Claim, 8 Drawing Sheets

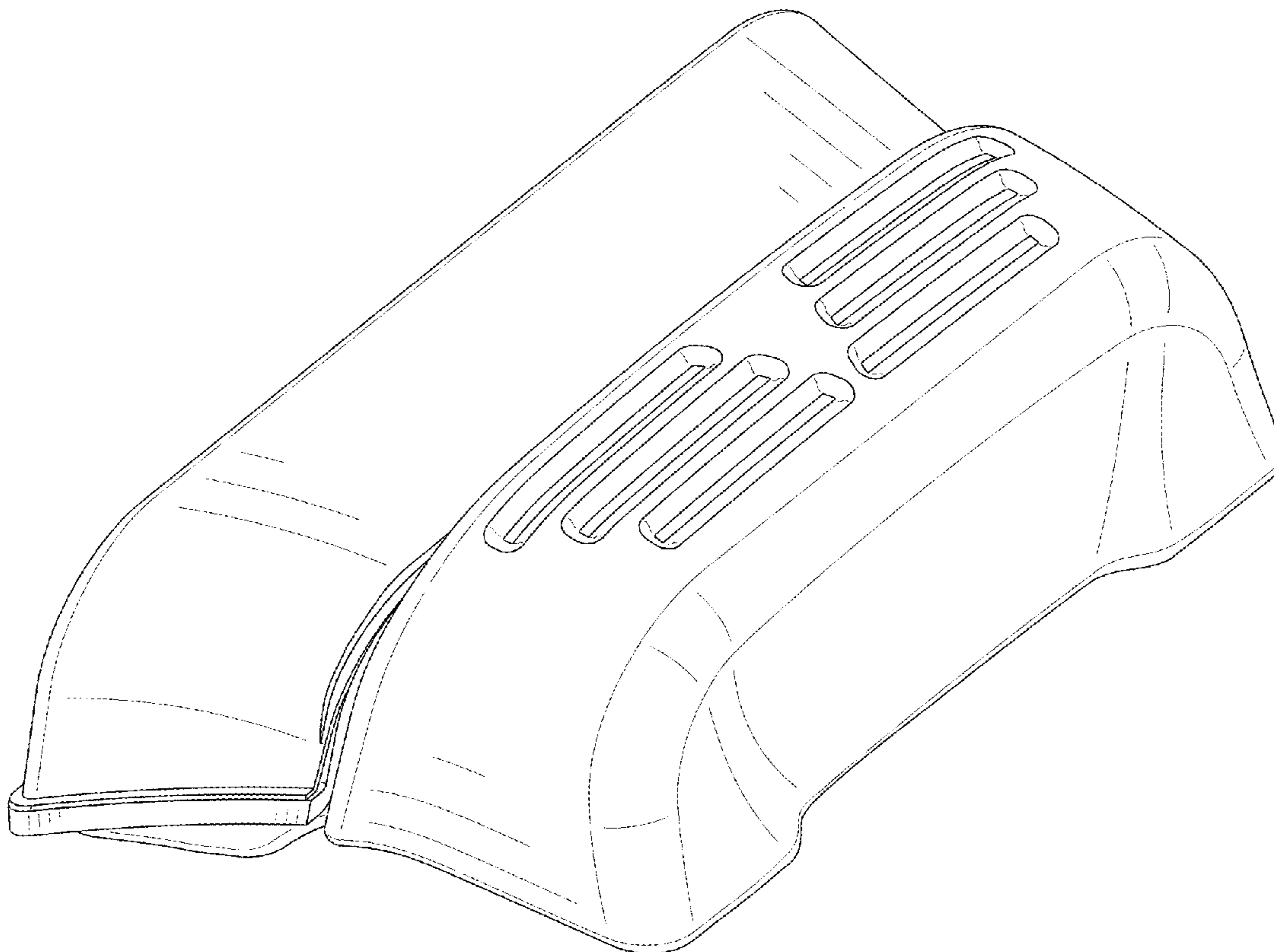

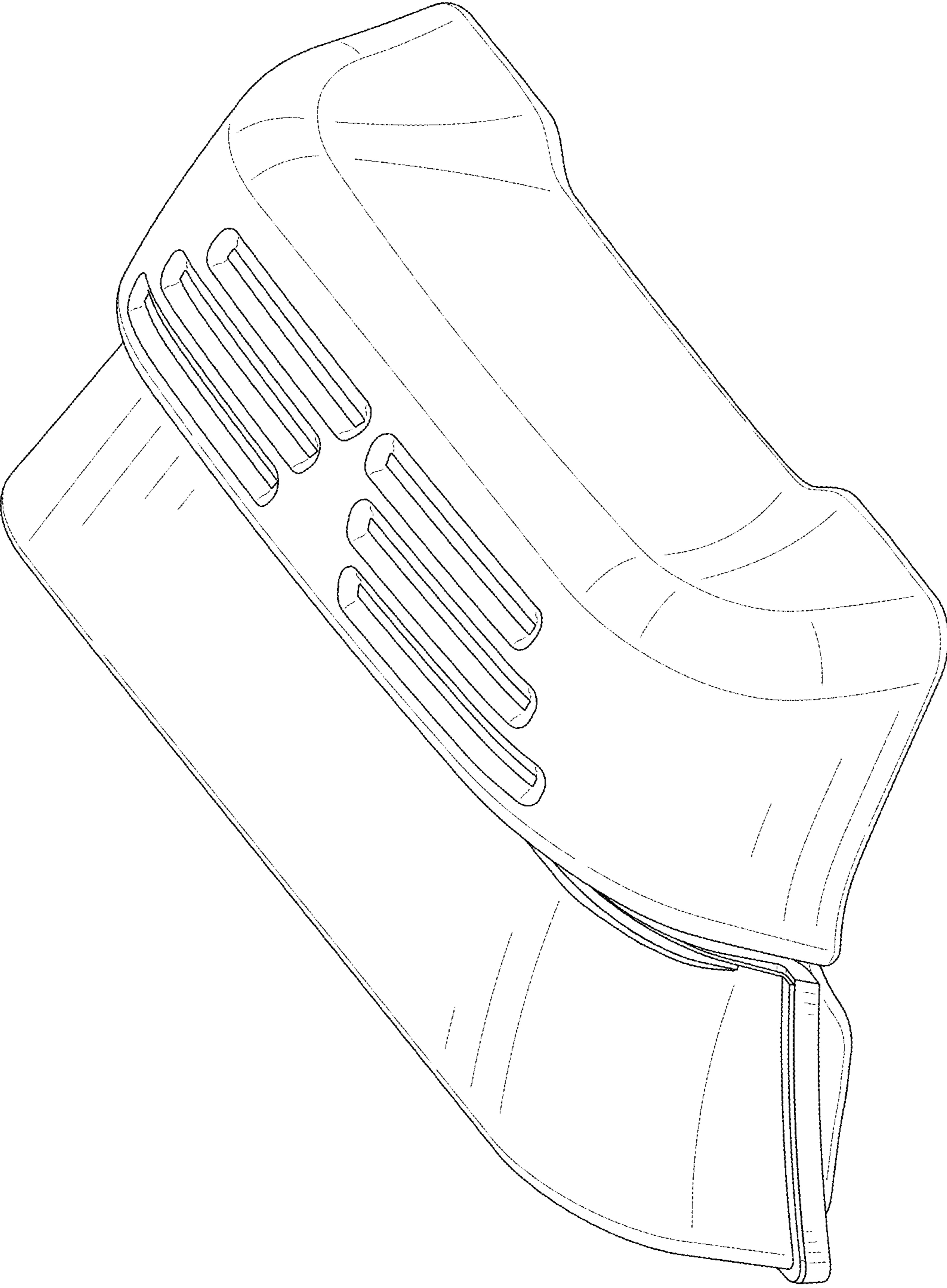

FIG. 1

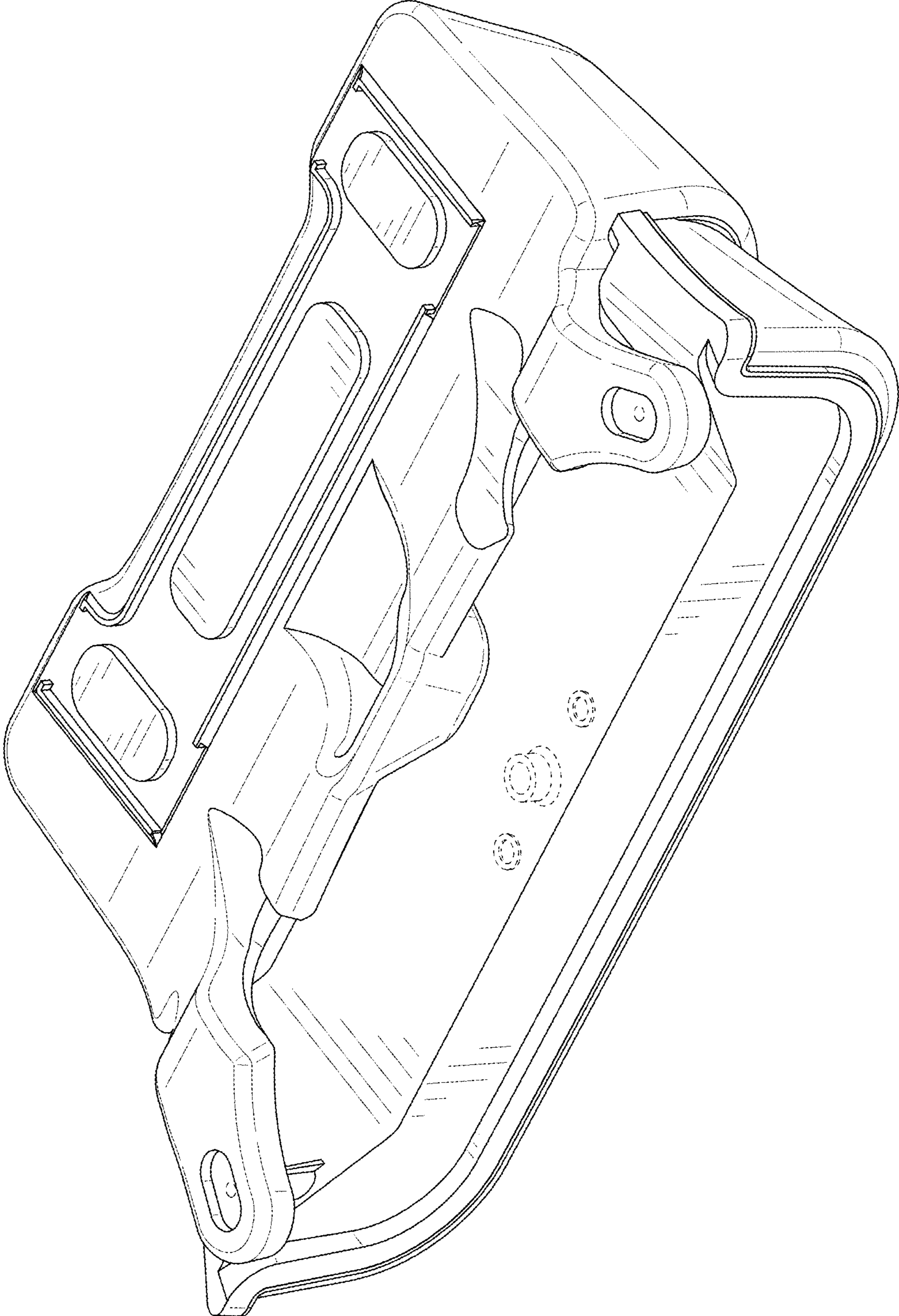

FIG. 2

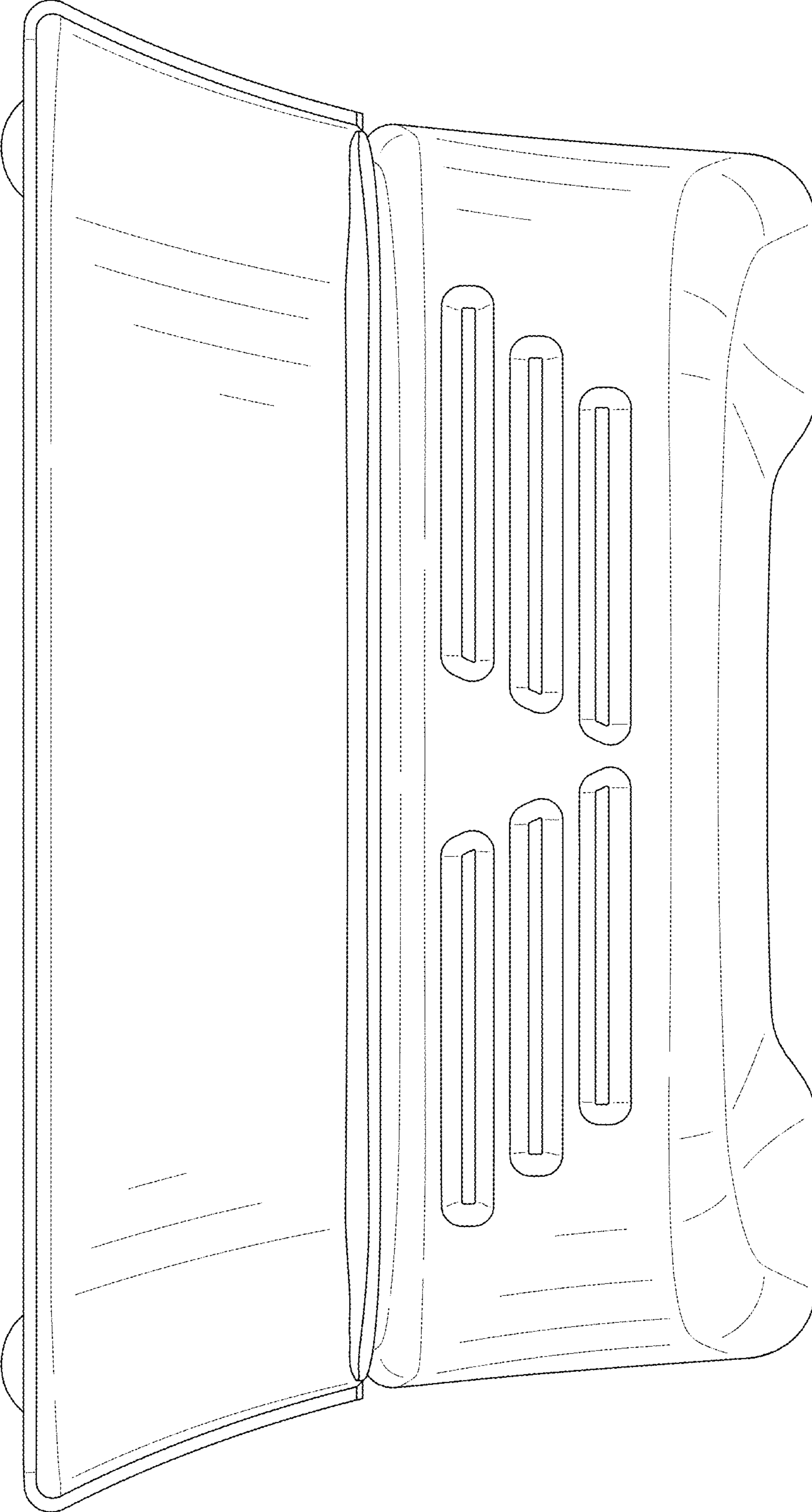

FIG. 3

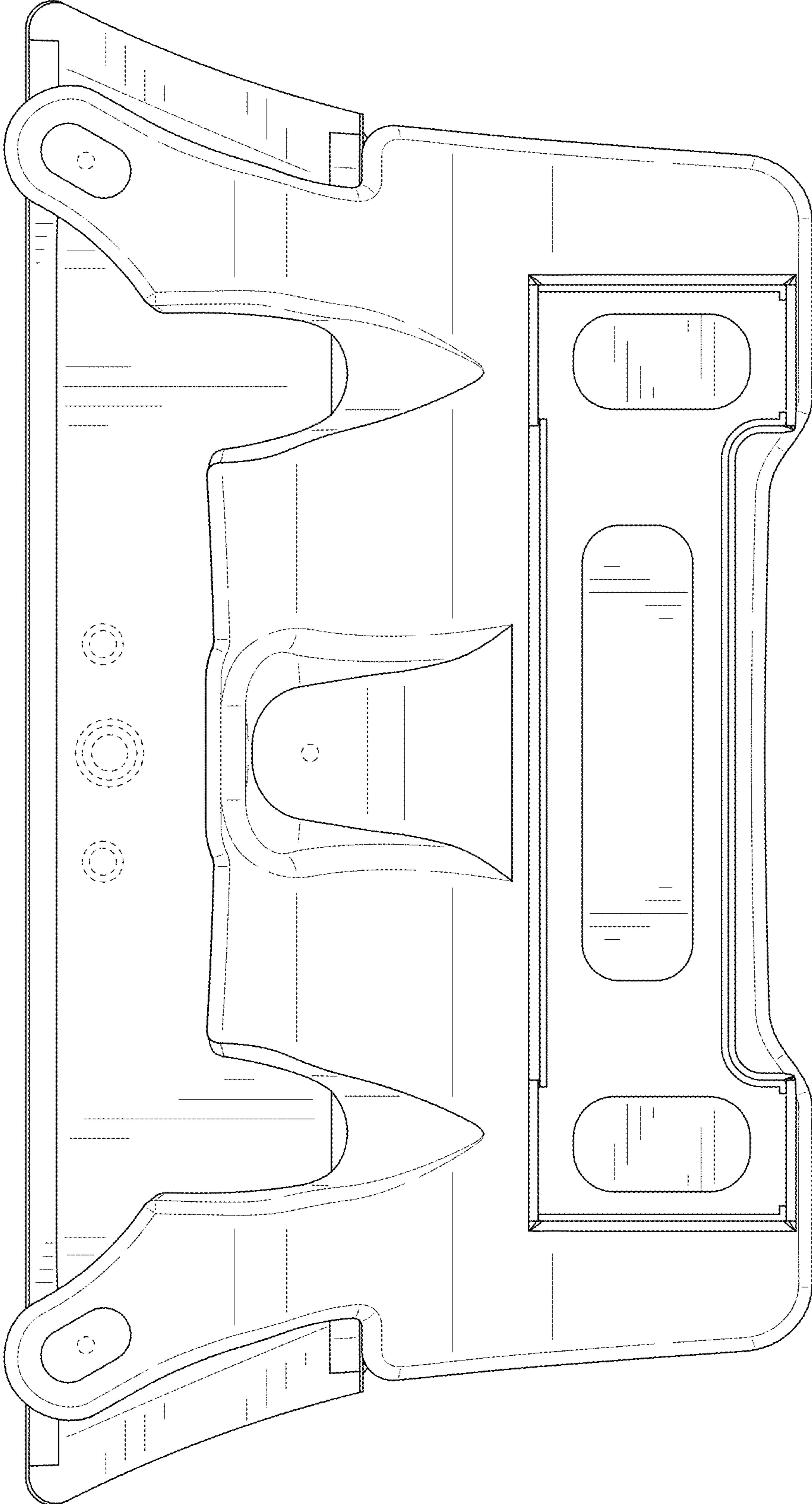

FIG. 4

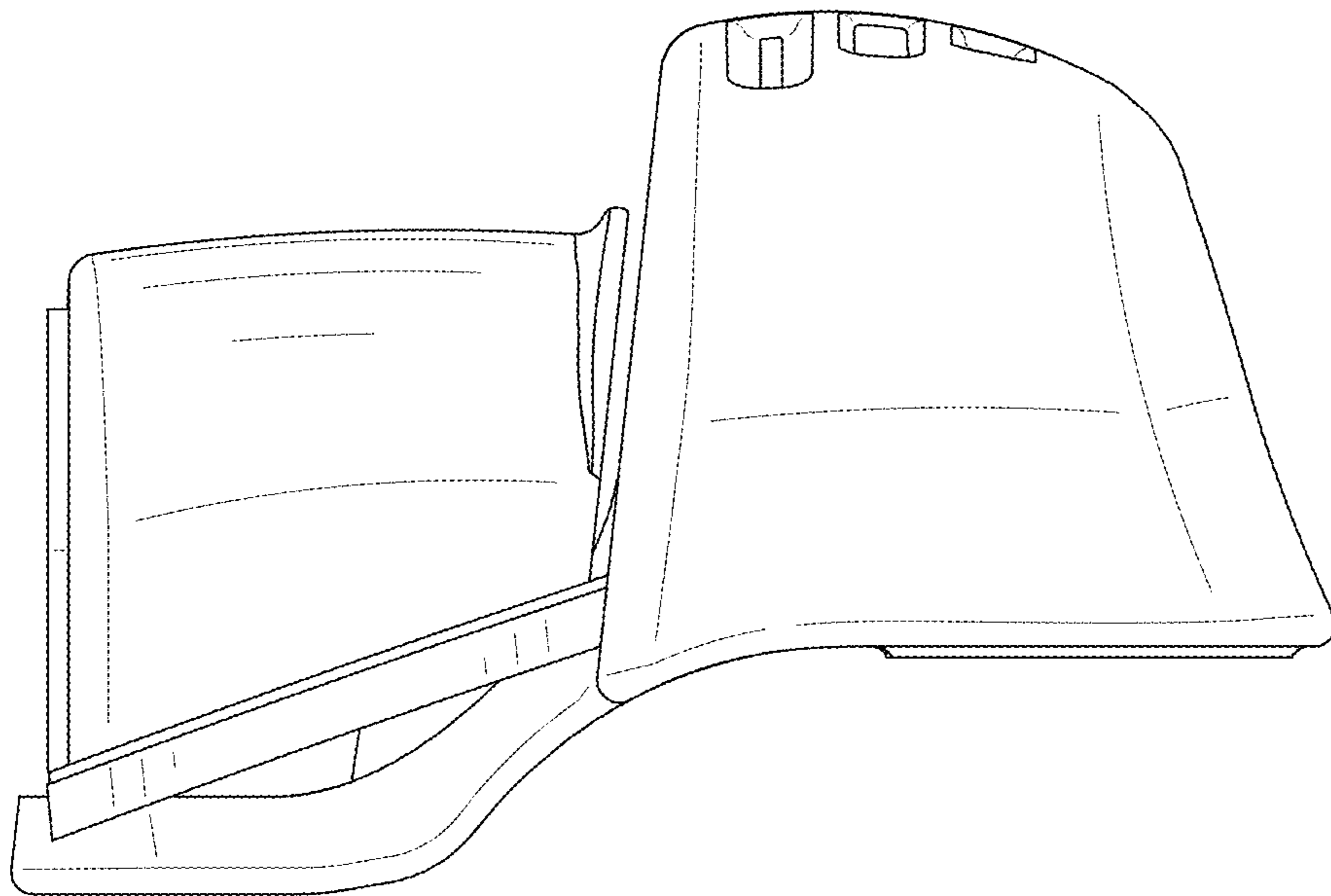

FIG. 5

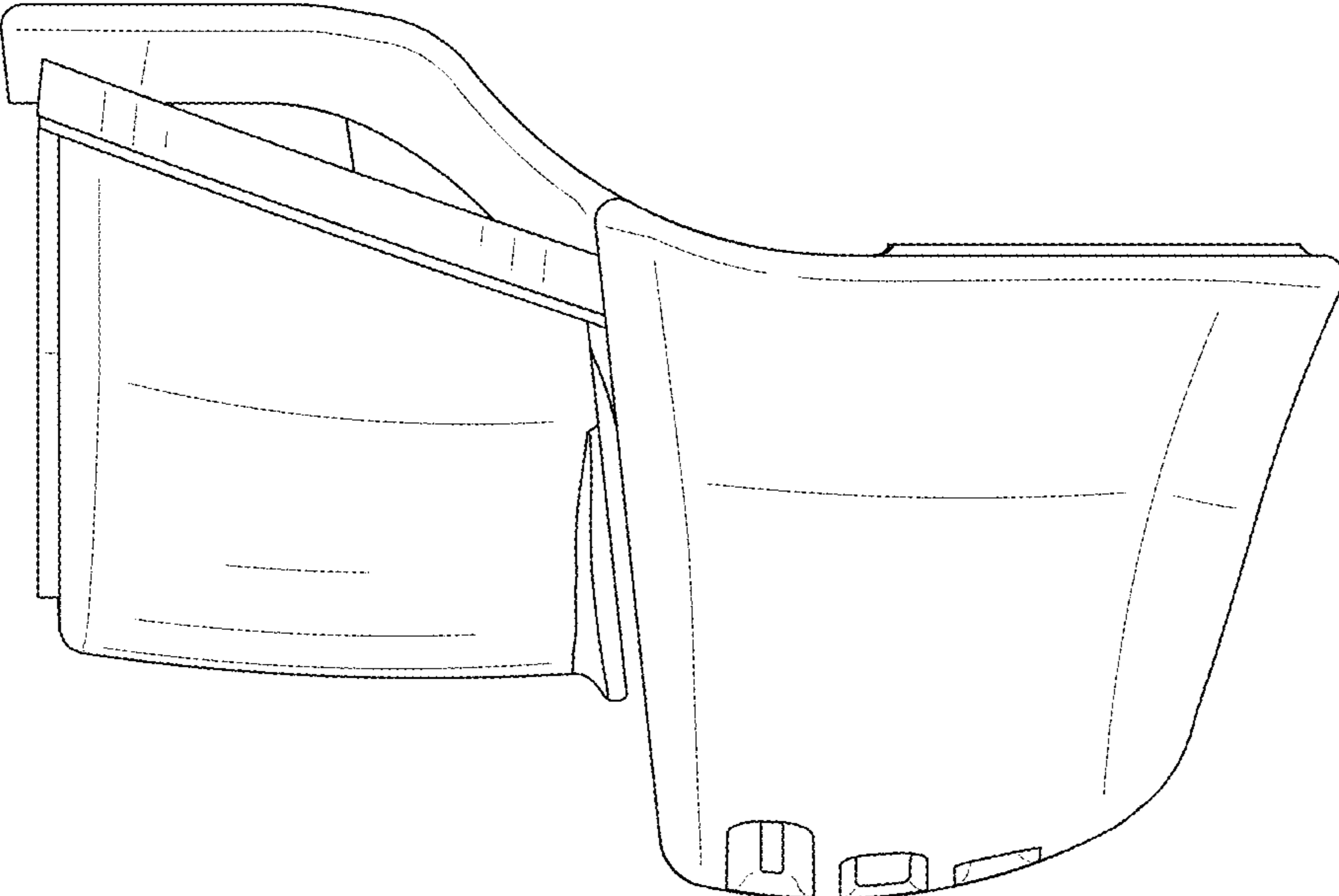

FIG. 6

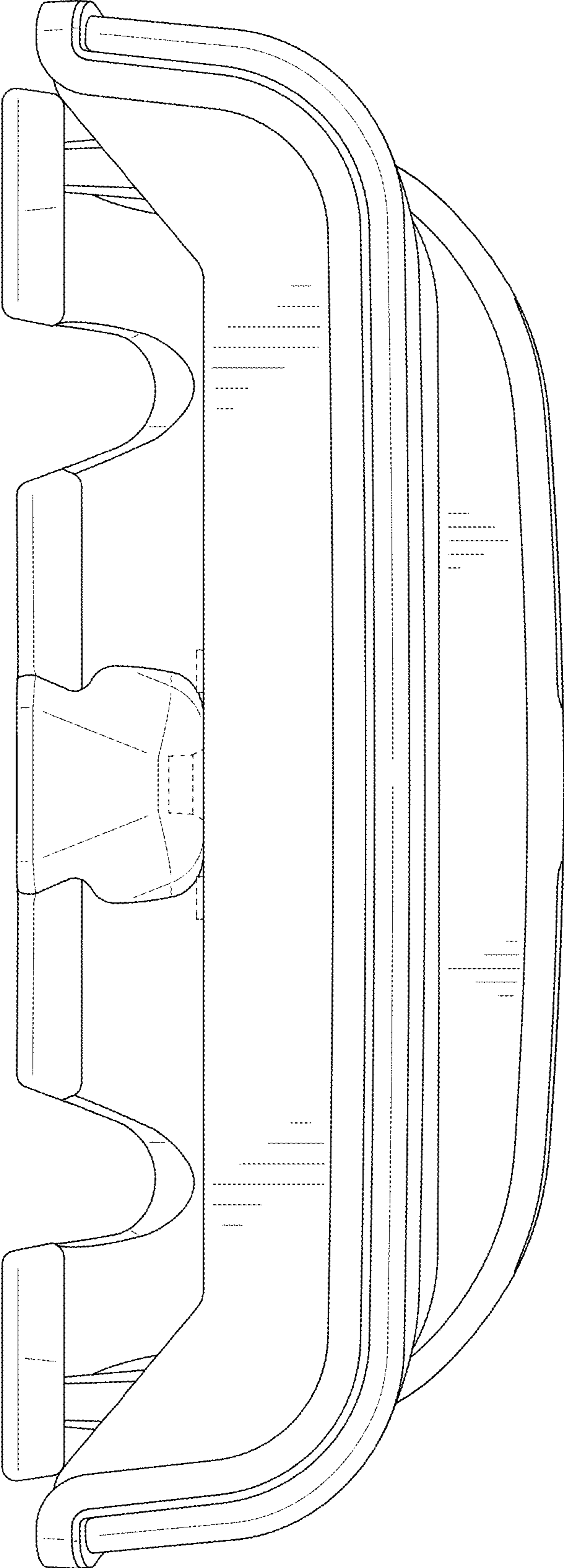

FIG. 7

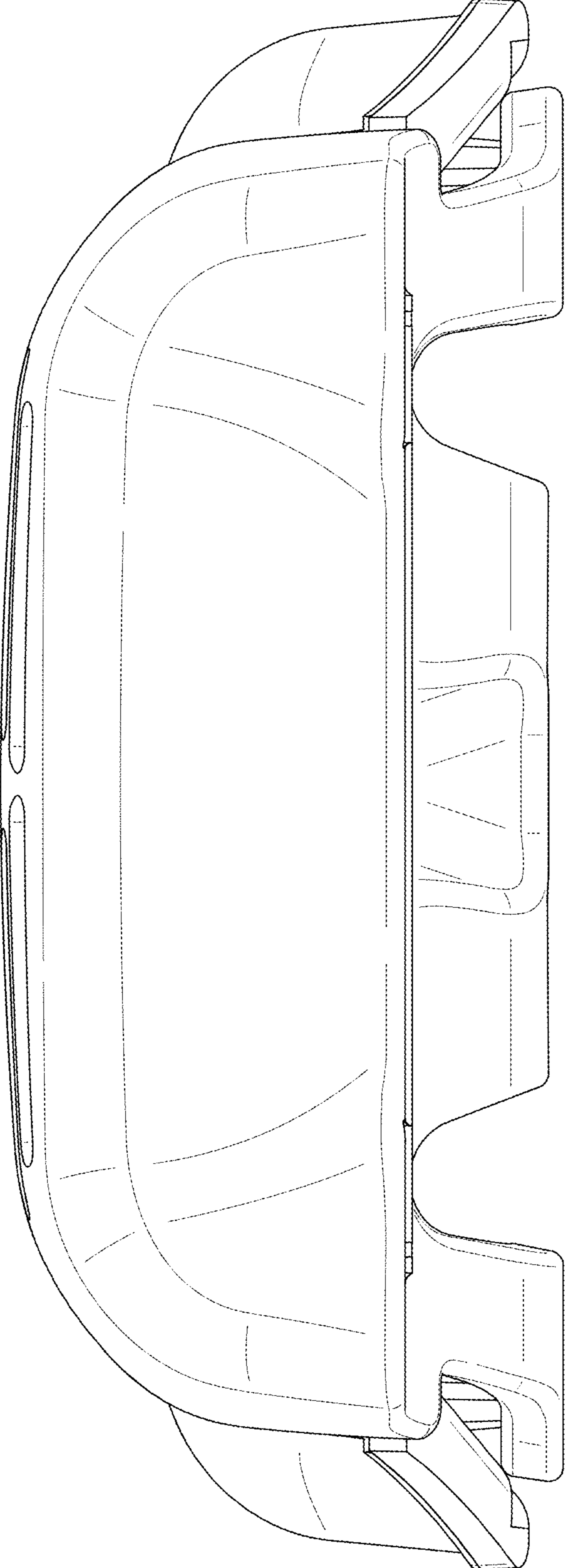

FIG. 8