



US00D955503S

(12) **United States Design Patent** (10) **Patent No.:** **US D955,503 S**  
**Ewing et al.** (45) **Date of Patent:** **\*\* Jun. 21, 2022**

(54) **MODEL VEHICLE SHOCK TOWER**

FOREIGN PATENT DOCUMENTS

(71) Applicant: **TRAXXAS LP**, McKinney, TX (US)  
(72) Inventors: **Adam Cole Ewing**, McKinney, TX (US); **Otto Karl Allmendinger**, Rowlett, TX (US); **Kent Poteet**, Lucas, TX (US)  
(73) Assignee: **TRAXXAS, L.P.**, McKinney, TX (US)  
(\*\*) Term: **15 Years**

DE 2137757 B2 2/1973  
TW D135320 S 6/2010  
TW D139245 S 3/2011

OTHER PUBLICATIONS

2Pcs RC Model Car Shock Tower Upgrade Parts for Xinlehong Q901, Q902, Q903, Earliest Available Date Oct. 22, 2019 [Online], [Site Visited Oct. 20, 2020] Available From Internet, URL: <https://www.newegg.com/p/1SW-00TF-00H35> (Year: 2019).\*

(Continued)

(21) Appl. No.: **29/696,533**  
(22) Filed: **Jun. 28, 2019**  
(51) **LOC (13) Cl.** ..... **21-01**  
(52) **U.S. Cl.**  
USPC ..... **D21/562**; D12/159  
(58) **Field of Classification Search**  
USPC ..... D21/424, 433, 434, 483, 495, 522, D21/533-562; D12/86-93, 98, 159, D12/163-172, 401; 446/431, 448, 446/454-456, 465-466, 470-471  
CPC ..... B60G 2204/128; B60G 13/003; B62D 25/00; B62D 35/00; A63H 17/262; A63H 17/00; A63H 17/395; A63H 17/38; A63H 17/26; A63H 17/28; A63H 33/042; A63H 3/16; A63H 3/50; A63H 30/00; A63H 7/04; A63H 17/36; A63H 17/264  
See application file for complete search history.

Primary Examiner — Cynthia M. Chin

(74) *Attorney, Agent, or Firm* — Daryl R. Wright; Greg Carr

(57) **CLAIM**

We claim the ornamental design for a model vehicle shock tower, as shown and described.

**DESCRIPTION**

FIG. 1 is an upper, right, front perspective view of a model vehicle shock tower, according to our new design; FIG. 2 is front elevation view thereof; FIG. 3 is a rear elevation view thereof; FIG. 4 is a right side elevation view thereof; FIG. 5 is a left side elevation view thereof; FIG. 6 is an upper plan view thereof; FIG. 7 is a lower plan view thereof; and, FIG. 8 is an upper, left, front perspective environmental use view of the model vehicle shock tower. In the drawings, the broken lines immediately adjacent the shaded areas represent the bounds of the claim and all other broken lines represent features of the model vehicle shock tower that form no part of the claimed design. None of the broken lines form a part of the claim.

(56) **References Cited**  
U.S. PATENT DOCUMENTS

1,135,577 A 4/1915 Hague  
1,647,438 A 11/1927 De Ram  
1,695,379 A 12/1928 Keck  
1,998,477 A 4/1935 Wikander  
2,123,681 A 7/1938 Willgoos  
2,126,085 A 8/1938 Balz  
2,131,661 A 9/1938 Heyermans et al.  
2,186,065 A 1/1940 Fischer  
2,219,361 A 10/1940 Haberstump

(Continued)

**1 Claim, 8 Drawing Sheets**

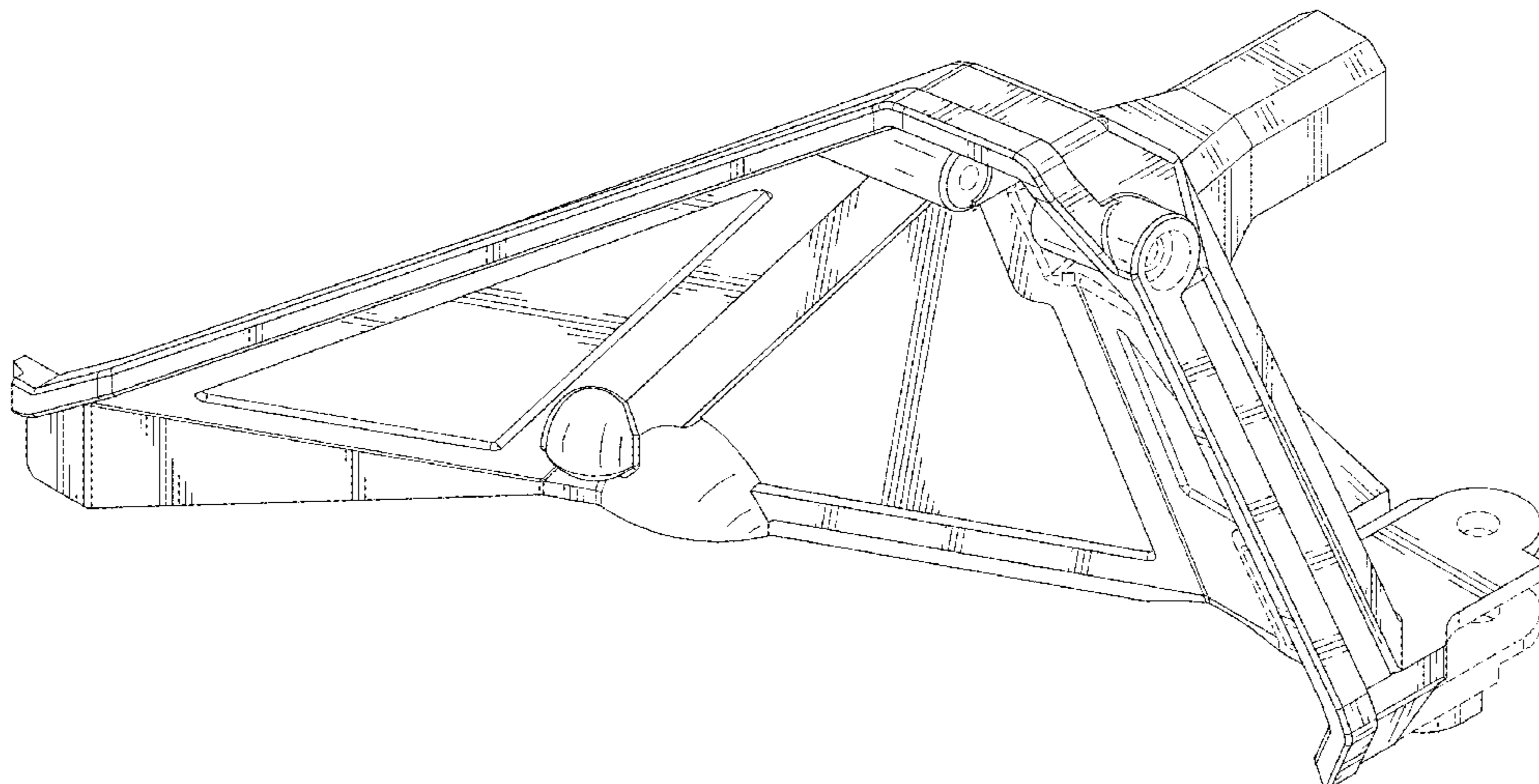

(56)

References Cited

U.S. PATENT DOCUMENTS

2,580,559 A 1/1952 Kolbe  
 2,643,110 A 6/1953 Gregoire  
 2,776,147 A 1/1957 Bamford  
 2,913,253 A 11/1959 Taber  
 2,931,663 A 4/1960 Ferand  
 2,992,014 A 7/1961 Muller  
 3,177,004 A 4/1965 Schmidt  
 3,448,991 A 6/1969 Leggett  
 3,545,125 A 12/1970 Okuma  
 3,591,198 A 7/1971 Brando  
 3,632,127 A 1/1972 Grosseau  
 3,671,694 A 6/1972 Masuda  
 3,721,455 A 3/1973 Blanton  
 3,727,938 A 4/1973 Goodbary et al.  
 3,738,631 A 6/1973 Haley  
 3,787,073 A 1/1974 Lievore  
 D262,959 S 2/1982 Cowan  
 4,470,611 A 9/1984 Dunphily et al.  
 D277,952 S 3/1985 Nakano et al.  
 4,534,575 A 8/1985 Grove et al.  
 D281,772 S 12/1985 Heidman et al.  
 D295,769 S 5/1988 Olsen  
 4,786,075 A 11/1988 Takahashi  
 D304,221 S 10/1989 Poulsen  
 4,881,752 A 11/1989 Tanaka  
 4,955,634 A 9/1990 Smith  
 5,071,384 A 12/1991 Poulsen  
 5,080,389 A 1/1992 Kawano et al.  
 5,108,126 A 4/1992 Banse  
 D337,555 S 7/1993 McNab et al.  
 D341,170 S 11/1993 Olsen  
 5,536,035 A 7/1996 Bautz et al.  
 5,682,489 A 10/1997 Harrow et al.  
 5,774,984 A 7/1998 Kotani  
 5,839,742 A 11/1998 Holt  
 5,845,926 A 12/1998 Davis et al.  
 D409,681 S 5/1999 Poulsen  
 D411,263 S 6/1999 Korsholm  
 6,047,988 A 4/2000 Aloe et al.  
 6,142,268 A 11/2000 Kuo-An  
 D435,236 S 12/2000 Hanlon et al.  
 6,170,838 B1 1/2001 Laurent et al.  
 D446,263 S 8/2001 Heys  
 D468,252 S 1/2003 Morris  
 6,550,796 B2 4/2003 Behr  
 6,641,457 B1 11/2003 Lai  
 6,655,118 B1 12/2003 Thompson et al.  
 6,668,779 B2 12/2003 Hendriksma et al.  
 6,702,307 B2 3/2004 Becker et al.  
 6,719,313 B2 4/2004 Zadok  
 6,761,372 B2 7/2004 Bryant  
 D493,848 S 8/2004 Dunst  
 6,881,122 B2 4/2005 Bloch et al.  
 6,945,843 B1 9/2005 Motosko  
 7,185,902 B1 3/2007 Lloyd  
 D546,751 S 7/2007 Laatz  
 D567,886 S 4/2008 Lampert et al.  
 7,367,573 B2 5/2008 Kudo et al.  
 7,887,074 B2 2/2011 Byers et al.  
 D647,826 S 11/2011 Goettker  
 D779,392 S \* 2/2017 Hare ..... D12/159  
 9,855,975 B2 1/2018 Amemiya  
 D828,460 S \* 9/2018 Wood ..... D21/561  
 D839,363 S \* 1/2019 Ewing ..... D21/495  
 D856,432 S \* 8/2019 Ewing ..... D21/495  
 D865,079 S \* 10/2019 Ewing ..... A63H 17/262  
 D867,475 S \* 11/2019 Ewing ..... A63H 17/262  
 D21/561  
 2002/0041076 A1 4/2002 Becker et al.  
 2002/0077025 A1 6/2002 Wu  
 2002/0125676 A1 9/2002 Bryant  
 2003/0122336 A1 7/2003 Zadok  
 2003/0209217 A1 11/2003 Hendriksma et al.  
 2004/0045518 A1 3/2004 Abe

2004/0261739 A1 12/2004 Shimizuya  
 2005/0040619 A1 2/2005 Melcher  
 2006/0006622 A1 1/2006 Gesmer et al.  
 2012/0169023 A1 7/2012 Rawlinson et al.  
 2016/0318362 A1 \* 11/2016 Watanabe ..... B60G 7/001  
 2017/0050483 A1 \* 2/2017 Gordon ..... B60G 3/145  
 2017/0274932 A1 \* 9/2017 Byrnes, Jr. .... B60G 7/008  
 2019/0070919 A1 \* 3/2019 Andou ..... B60G 21/026  
 2019/0367117 A1 12/2019 Fischer et al.

OTHER PUBLICATIONS

1 \_ 28 RC Car Upgraded Metal Part Shock Tower for Wltoys P929 P939 K969 K979 K989 K999, Earliest Available Date Oct. 20, 2020 [Online], [Site Visited Oct. 20, 2020] Available From Internet, URL: <[https://www.gearbest.com/rc-car-parts/pp\\_009793593021.html](https://www.gearbest.com/rc-car-parts/pp_009793593021.html)> (Year: 2020).\*

Associated Electrics, “Monster GT” model truck; Associated Electrics, Inc., Costa Mesa, California, 1 photograph.  
 Associated Electrics, “RC10GT” model vehicle; Associated Electrics, Inc., Costa Mesa, California, 1 photograph.  
 Bradley, John; “The Racing Motorcycle”; 1996, pp. 246-273, 322-325; Broadland Leisure Publications, England.  
 Ellsworth, Tony; “Suspension Design Enhancements—The Ellsworth Dare”; Dreamride Mountain Bike Tours and Film Services, Moab, Utah, 2001.  
 Horizon Hobby, “Losi XXX buggy”; Horizon Hobby, Inc., Champaign, Illinois; 1 sketch of suspension geometry.  
 HPI Racing, “Savage 21” model truck; Hobby Products International, Foothill Ranch, California; 1 sketch of suspension geometry.  
 HyperPRO\_USA; “What is Progressive Suspension?” HyperPRO\_USA.com.  
 Kyosho Inferno MP7.5 model car; Kyosho America, Lake Forest, California; 2 sketches of suspension geometry.  
 Milliken, William F. and Milliken, Douglas L.; “Race Car Vehicle Dynamics” 1995, pp. 580-583, 595-597, 628-631; SAE Publications Group, Pennsylvania USA.  
 Phillipotts, Peter; “Rising Rate Suspension”; Off Road Design, 2001.  
 Race Tech, “Profile—Chalmers Formula SAE Car” Race Tech magazine, Oct./Nov. 2003, p. 74; Racecar Graphic Ltd, London, England.  
 Racecar Engineering, Jun. 2003—vol. 13 No. 06, pp. 15, 106; Country & Leisure Media Ltd./IPC Media Ltd., Croydon, England.  
 Salven, Michael; “Progressive Suspension” Nov. 10, 2000; myTSN—Publication, Netherlands.  
 Serpent, Veteq; Serpent Model Racing Cars, Noord-Holland, Netherlands; 3 pictures.  
 Serpent, Veteq; Serpent Model Racing Cars, Noord-Holland, Netherlands; 1 sketch of suspension geometry.  
 Staniforth, Allan; “Competition Car Suspension” 1988, pp. 76-81, 84-85; Haynes Publications, Newbury Park, California.  
 Tamiya, “Terra Crusher” model truck; Tamiya America, Inc., Aliso Viejo, California; 1 sketch of suspension geometry.  
 Traxxas, “Nitro Rustler” model vehicle; Traxxas LP, Plano, Texas; 1 photograph.  
 Traxxas; “T-MAXX Assemblies, Front Assembly” exploded view; Traxxas LP, Plano, Texas.  
 Traxxas, “T-MAXX” model vehicle; Traxxas LP, Plano, Texas; 1 photograph.  
 Full size vehicle with suspension linkage #1.  
 Full size vehicle with suspension linkage #2.  
 Axial SCX10 II Shock Hoops AX131380; <http://www.axialracing.com/products/ax131380>; Aug. 2016.  
 HPI Venture FJ Cruiser; <http://www.hpiracing.com/en/article/view/2016012702>; Jan. 27, 2016.  
 Taiwan IPO Search Report, Taiwan Design App No. 105301437; dated Aug. 4, 2016.  
 Taiwan IPO Search Report, Taiwan Design App No. 106300762; dated May 16, 2017.  
 L. Granieri; U.S. Pat. No. 903,080; Road Vehicle Wheel Axle; Nov. 3, 1908.

(56)

**References Cited**

OTHER PUBLICATIONS

H. Ewing; U.S. Pat. No. 951,000; Spring Controlled Vehicle Wheel Link; Mar. 1, 1910.

\* cited by examiner

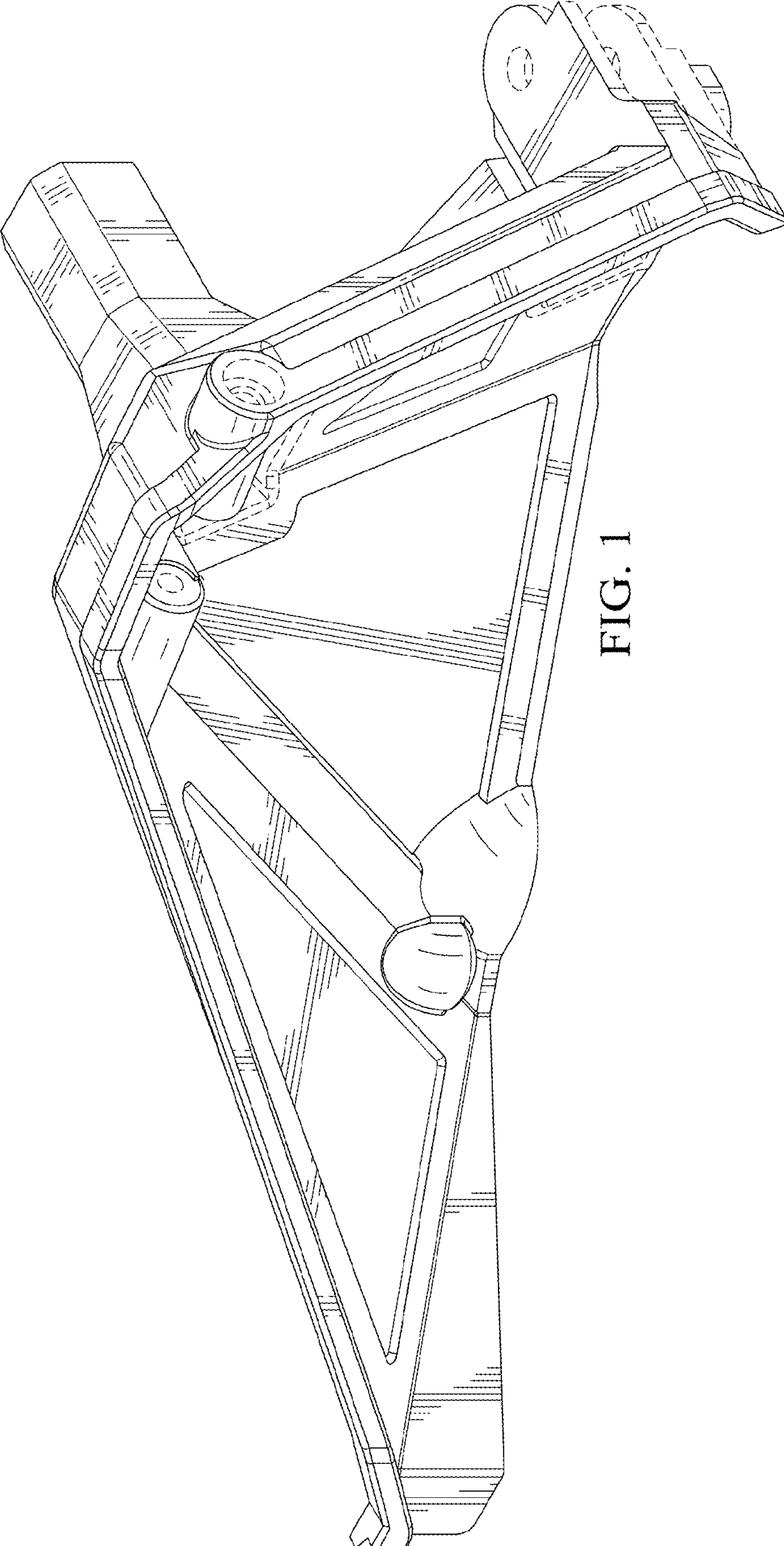

FIG. 1

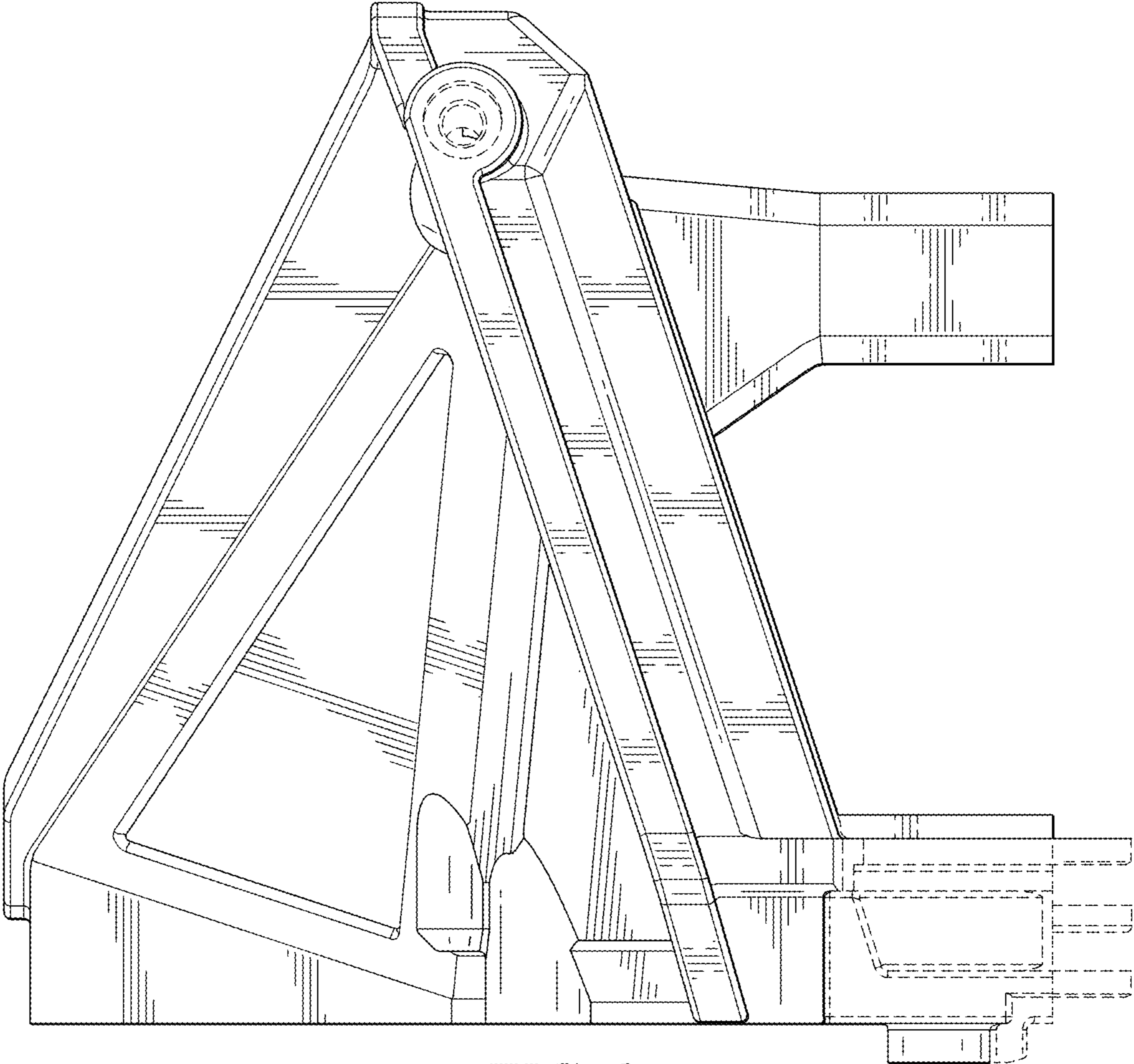

FIG. 2

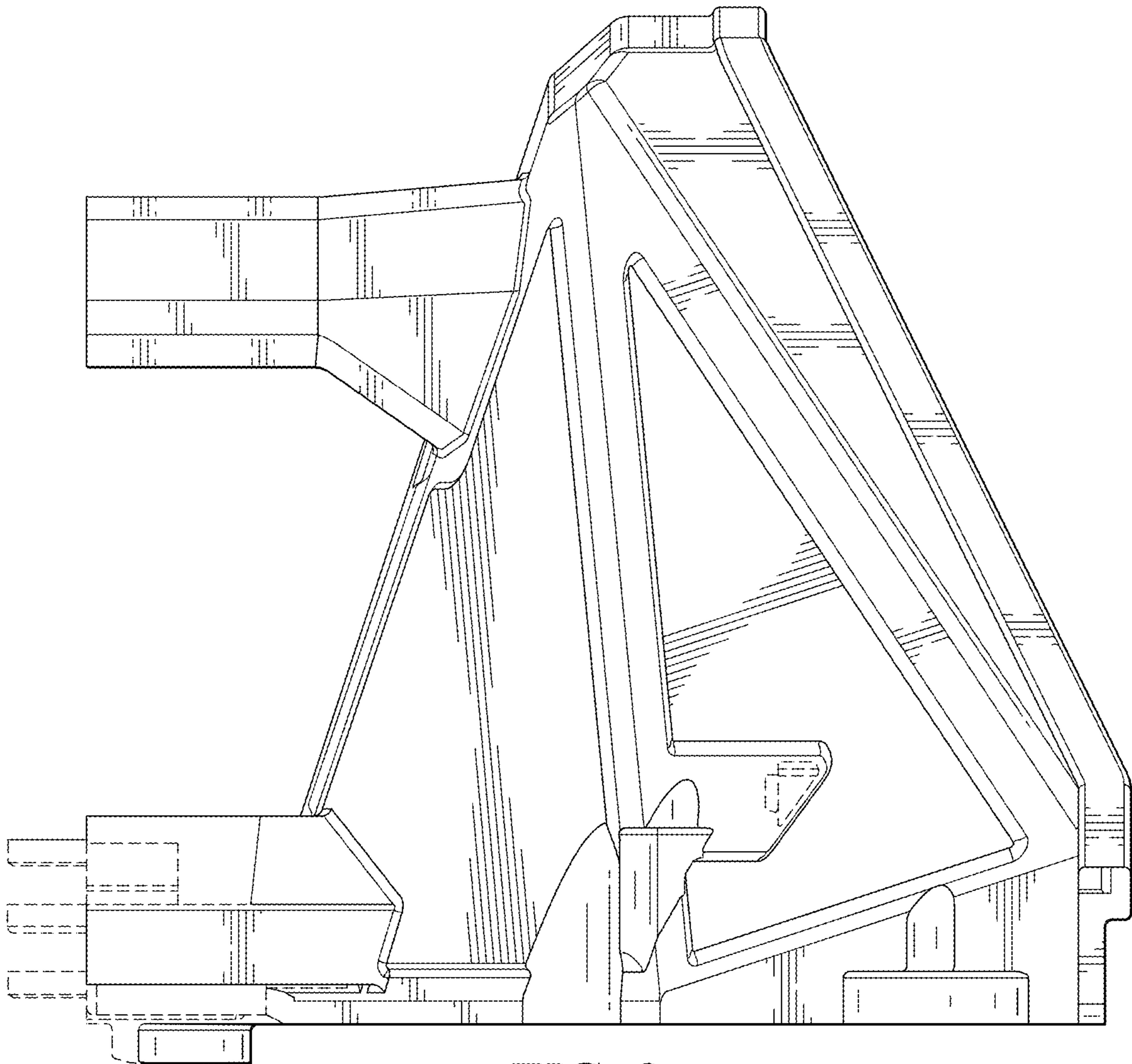

FIG. 3

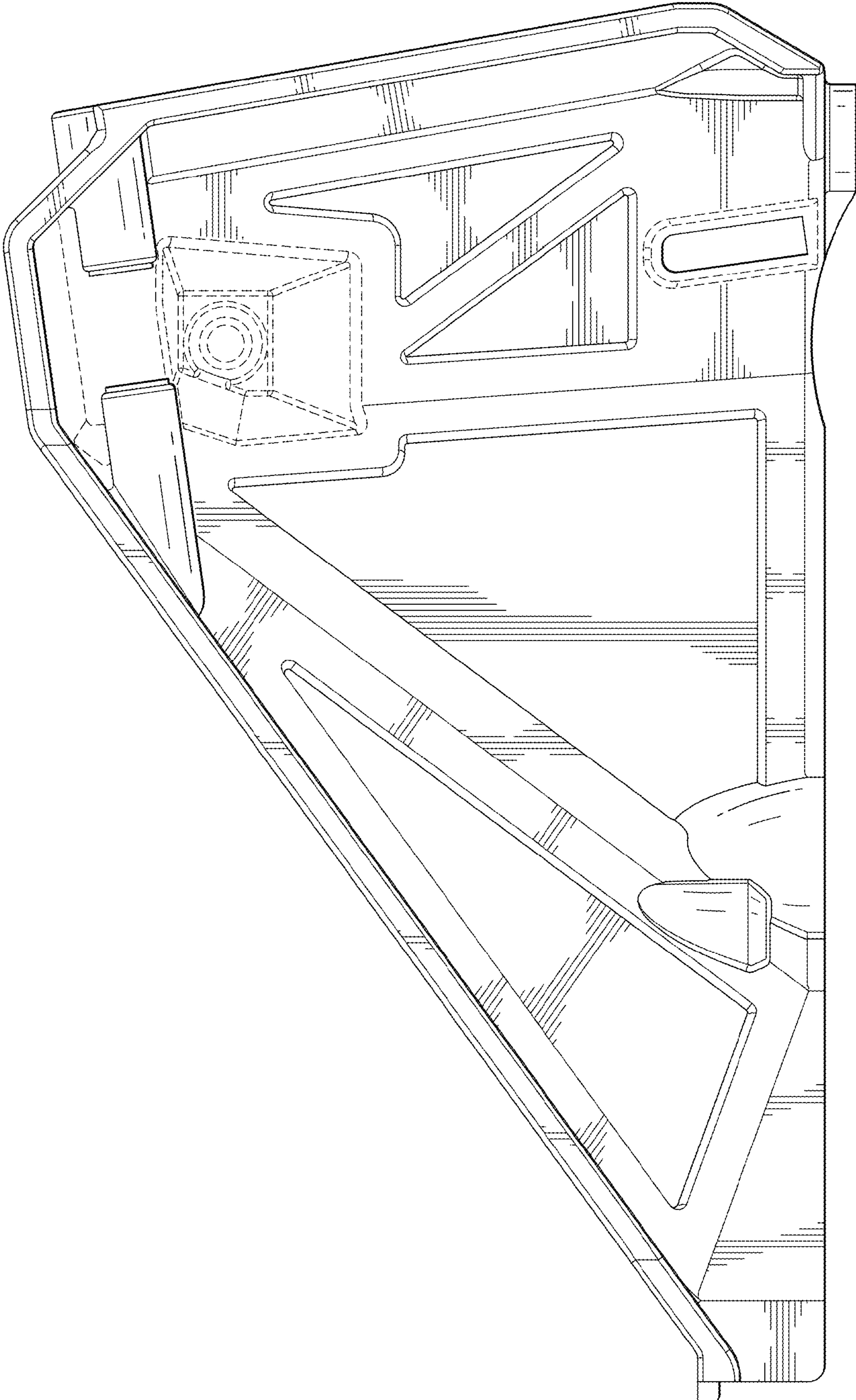

FIG. 4

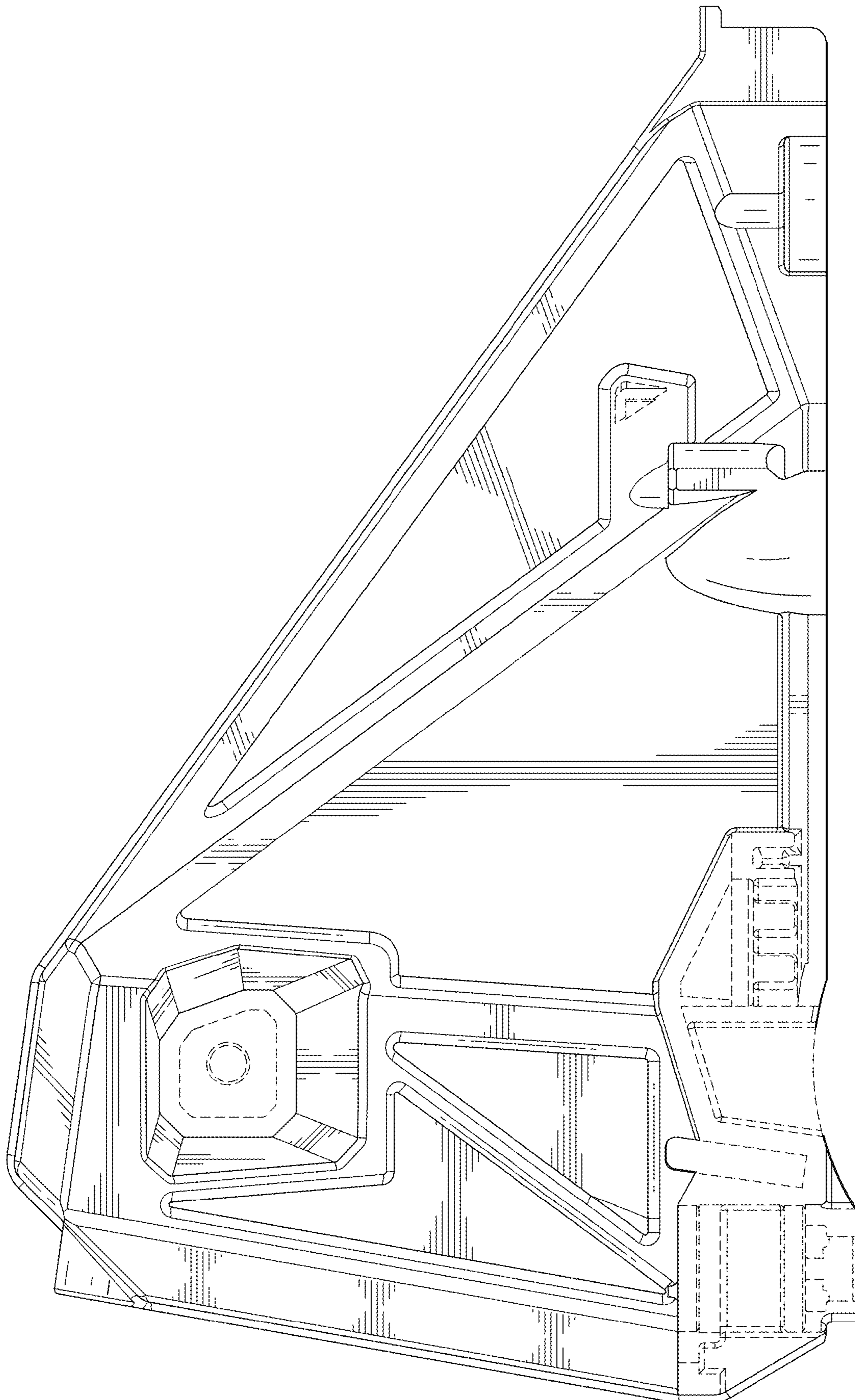

FIG. 5



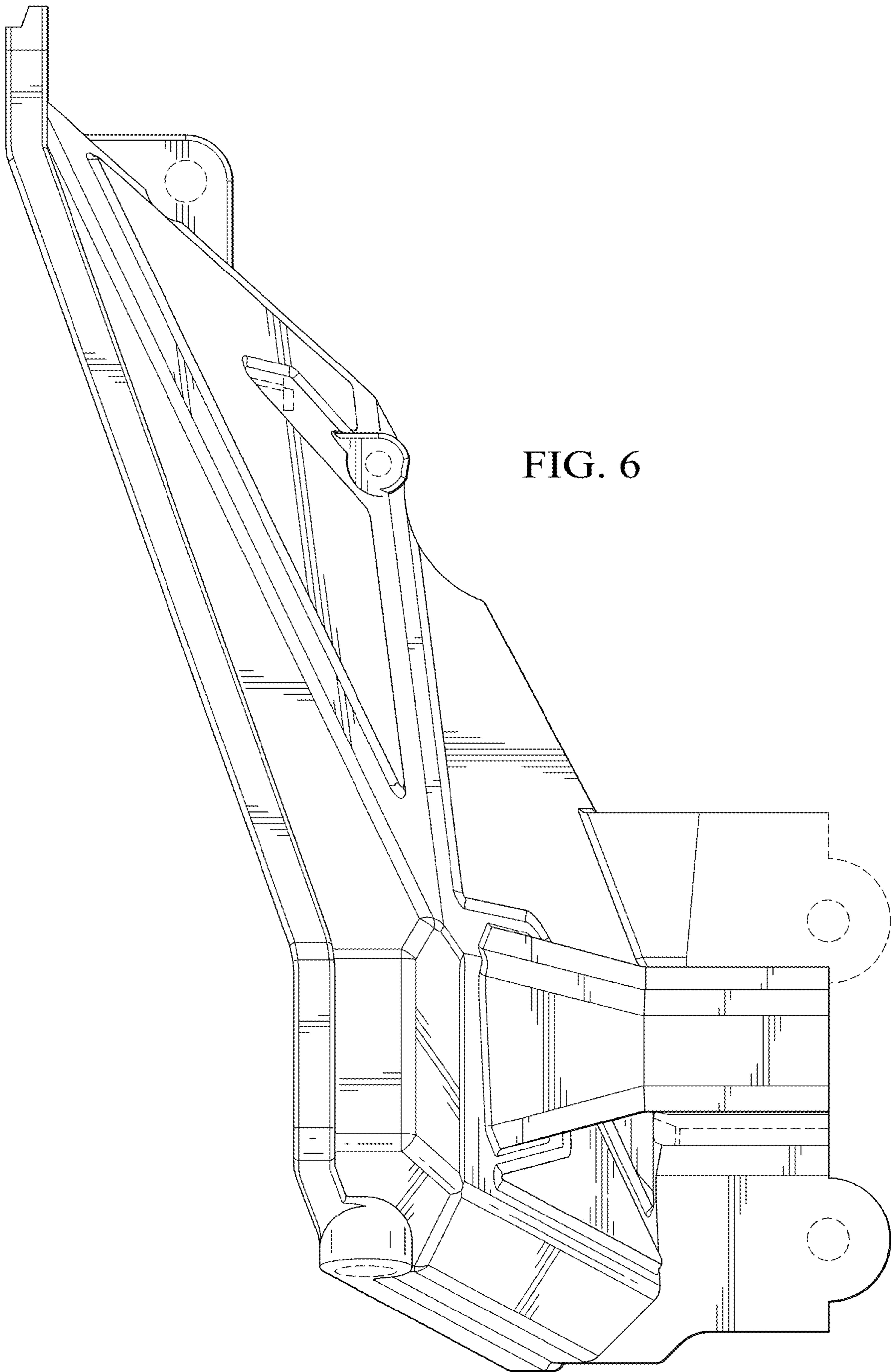

FIG. 6

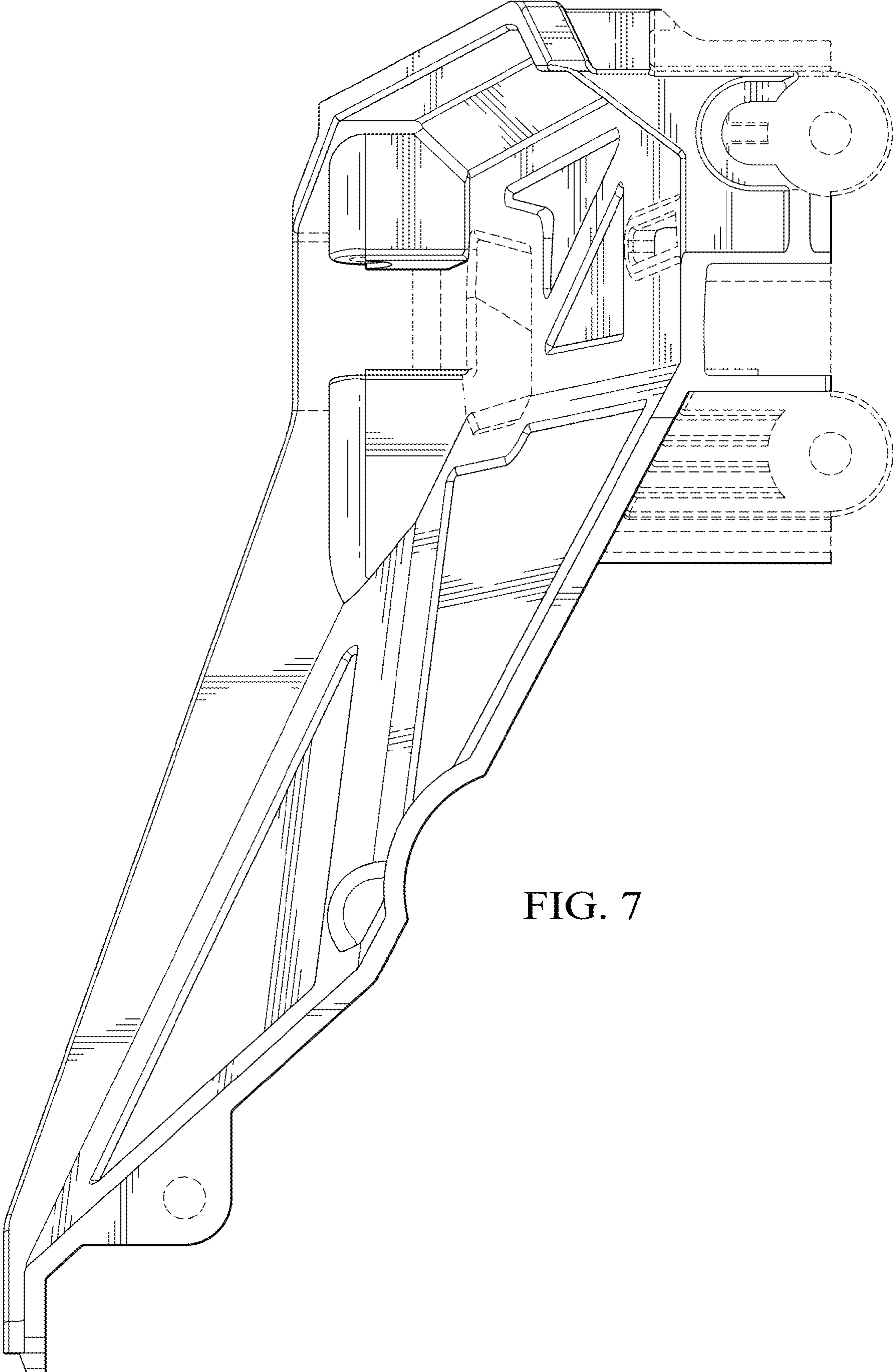

FIG. 7

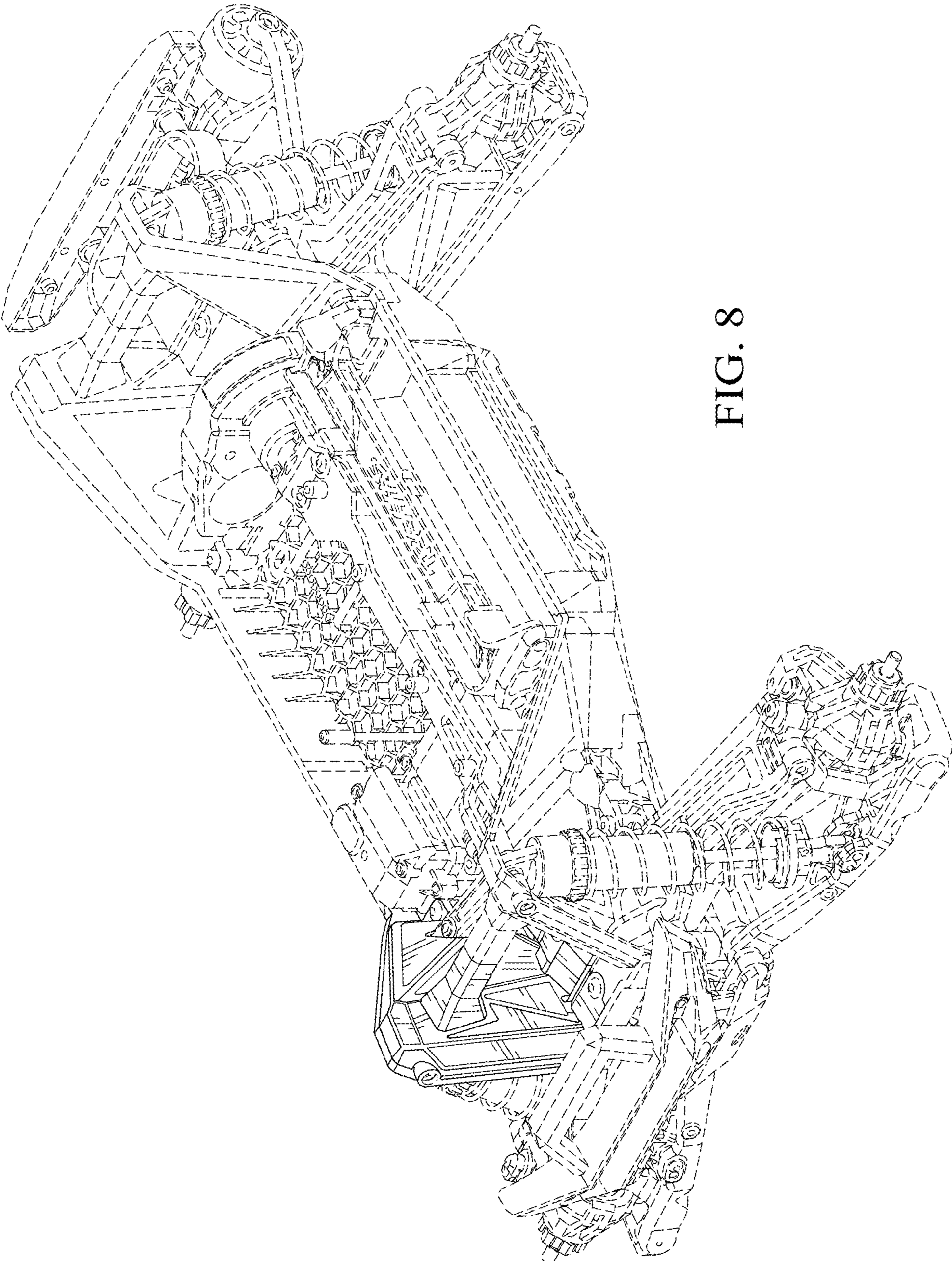

FIG. 8