



US00D954852S

(12) **United States Design Patent** (10) **Patent No.:** **US D954,852 S**  
**Baumgartner** (45) **Date of Patent:** **\*\* Jun. 14, 2022**

(54) **VEHICLE FRAME**

(56) **References Cited**

(71) Applicant: **Herbert Thomas Baumgartner**,  
Magnolia, TX (US)  
(72) Inventor: **Herbert Thomas Baumgartner**,  
Magnolia, TX (US)  
(\*\*) Term: **15 Years**  
(21) Appl. No.: **29/746,832**  
(22) Filed: **Aug. 18, 2020**

U.S. PATENT DOCUMENTS

D500,707 S *	1/2005	Lu	.....	D12/87
D503,658 S *	4/2005	Lu	.....	D12/87
D549,133 S *	8/2007	LePage	.....	D12/87
D563,274 S *	3/2008	Ramos	.....	D12/87
D564,410 S *	3/2008	Lepage	.....	D12/87
D574,297 S *	8/2008	Carl	.....	D12/87
D575,675 S *	8/2008	Williams	.....	D12/87
D586,261 S *	2/2009	Burns	.....	D12/87
D586,695 S *	2/2009	Burns	.....	D12/87
D586,696 S *	2/2009	Burns	.....	D12/87
D651,133 S *	12/2011	Liebl	.....	D12/87

\* cited by examiner

**Related U.S. Application Data**

(63) Continuation-in-part of application No. 29/676,084,  
filed on Jan. 8, 2019, now Pat. No. Des. 896,898,  
which is a continuation-in-part of application No.  
15/475,496, filed on Mar. 31, 2017, now Pat. No.  
10,207,561.  
(60) Provisional application No. 62/396,935, filed on Sep.  
20, 2016.  
(51) **LOC (13) Cl.** ..... **21-01**  
(52) **U.S. Cl.**  
USPC ..... **D21/426; D12/87**  
(58) **Field of Classification Search**  
USPC .... D21/412, 414, 431-435; D12/1, 87, 107,  
D12/110-114, 129, 130, 133  
CPC ..... A63G 25/00; B62D 21/183; B62D 39/00;  
B60K 7/0007  
See application file for complete search history.

*Primary Examiner* — Darlington Ly

(74) *Attorney, Agent, or Firm* — Pierson IP, PLLC

(57) **CLAIM**

The ornamental design for a vehicle frame, as shown and described.

**DESCRIPTION**

FIG. 1 is a perspective view of a vehicle frame showing my new design;  
FIG. 2 is a side elevation view thereof;  
FIG. 3 is an opposing side elevation view thereof;  
FIG. 4 is a top plan view thereof;  
FIG. 5 is a bottom plan view thereof;  
FIG. 6 is a front elevation view thereof; and,  
FIG. 7 is a rear elevation view thereof.

**1 Claim, 7 Drawing Sheets**

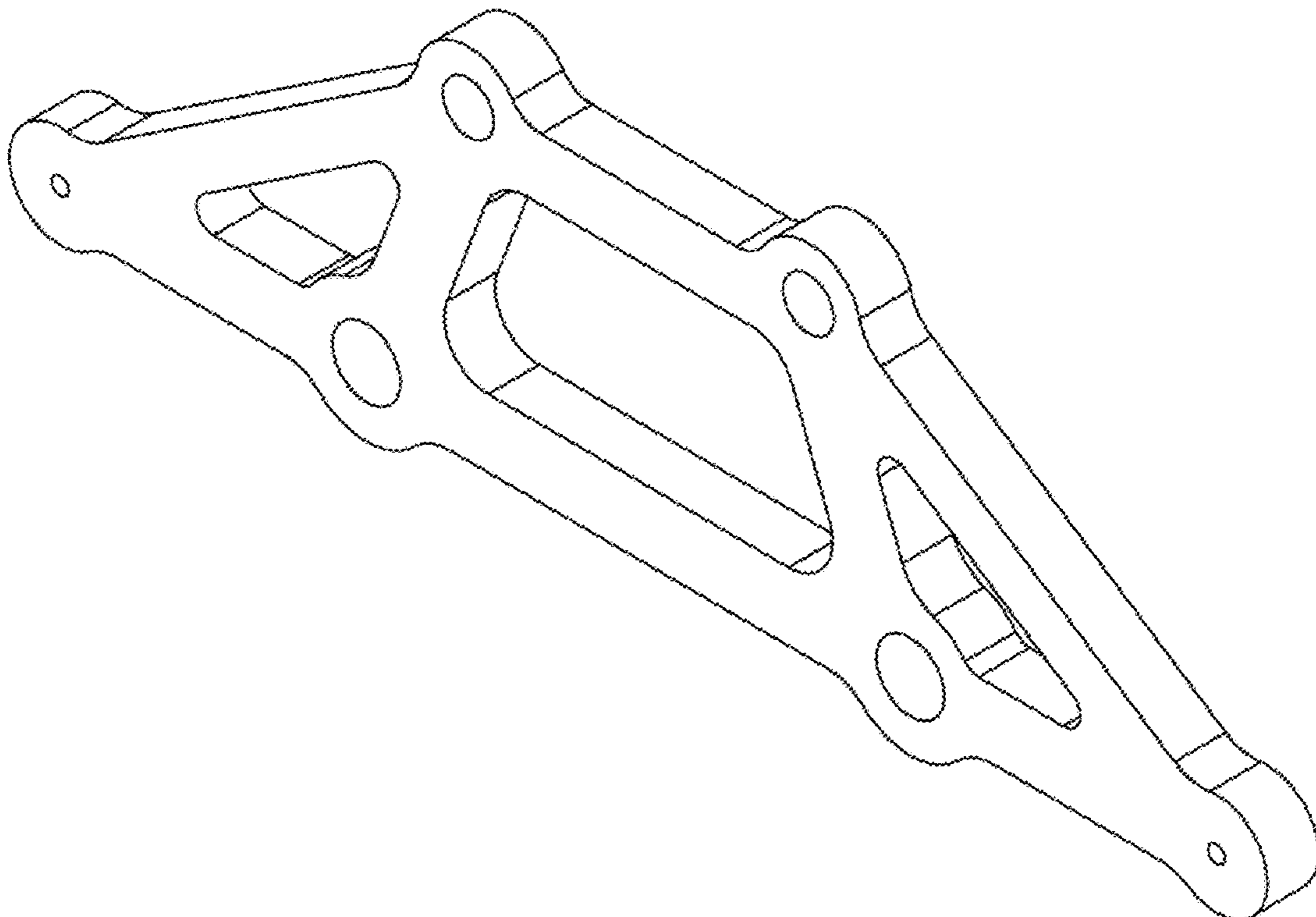

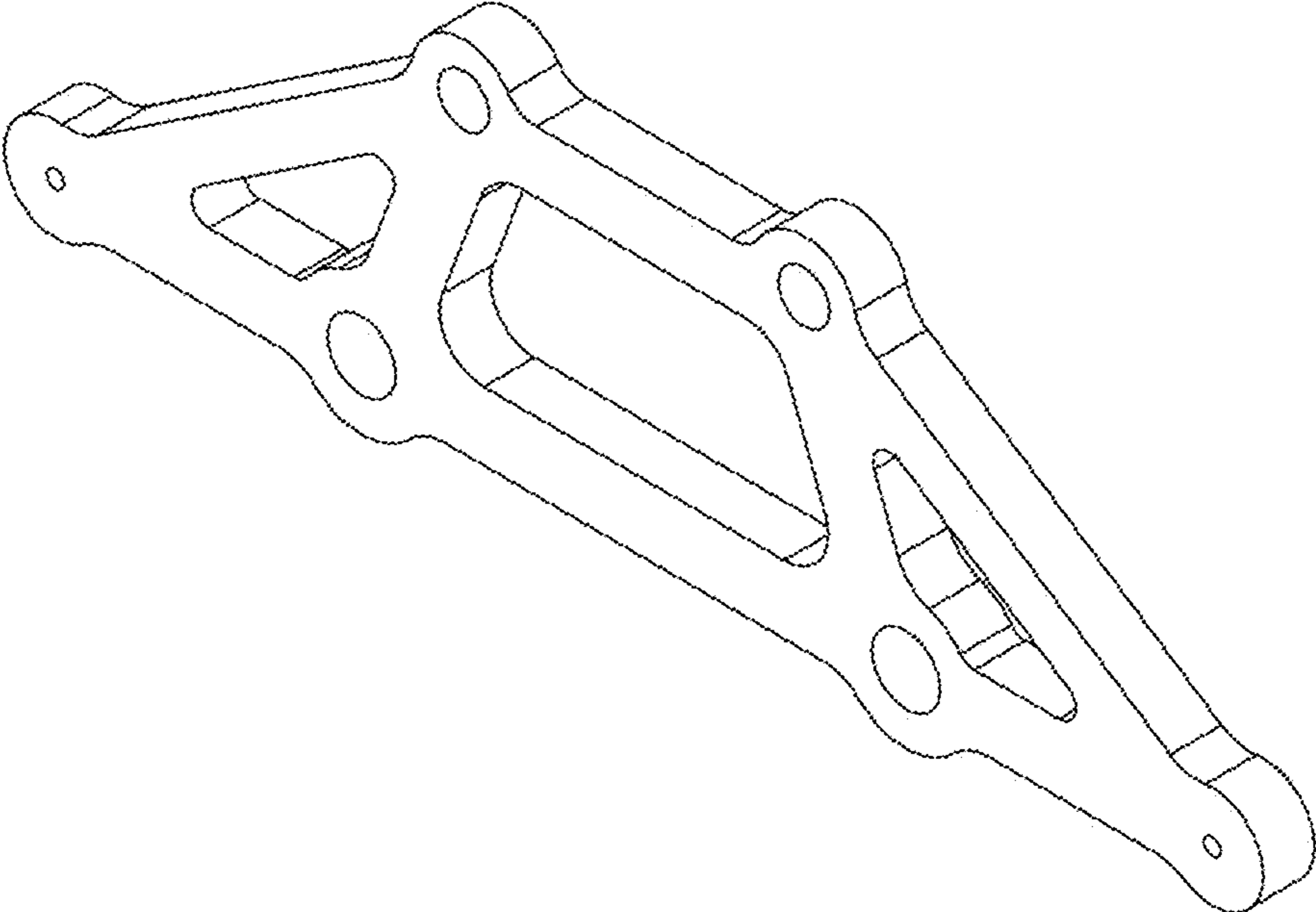

FIGURE 1

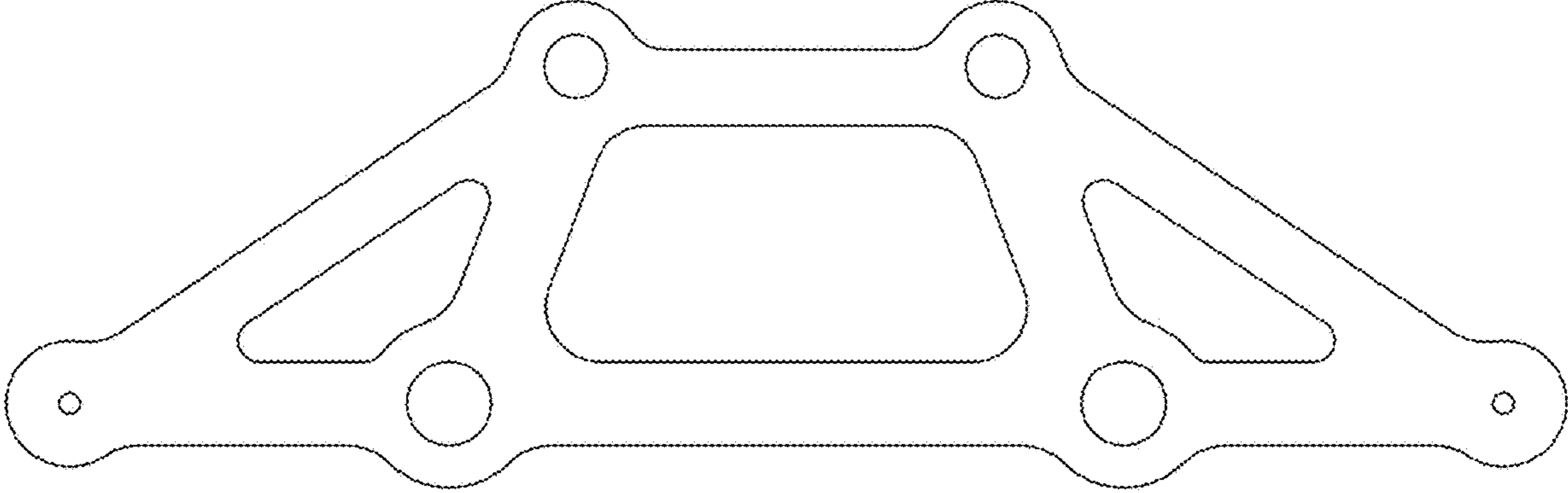

FIGURE 2

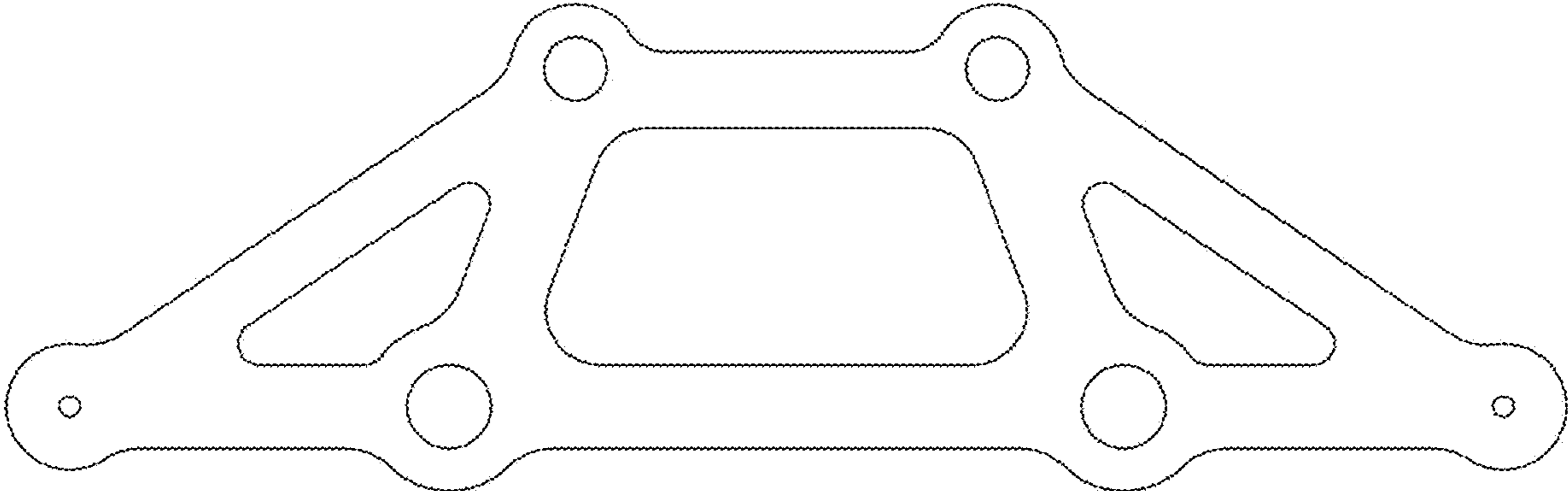

FIGURE 3



FIGURE 4



FIGURE 5



FIGURE 6



FIGURE 7