



US00D954571S

(12) **United States Design Patent** (10) **Patent No.:** **US D954,571 S**  
**Ahn et al.** (45) **Date of Patent:** **\*\* Jun. 14, 2022**

(54) **FRONT SENSOR HOUSING**

- (71) Applicant: **Waymo LLC**, Mountain View, CA (US)
- (72) Inventors: **YooJung Ahn**, Mountain View, CA (US); **Jared S. Gross**, Belmont, CA (US); **Thomas Southworth**, Royal Oak, MI (US); **Chun Chen**, Cupertino, CA (US); **Ricky Wong**, Mountain View, CA (US)
- (73) Assignee: **Waymo LLC**, Mountain View, CA (US)
- (\*\*) Term: **15 Years**
- (21) Appl. No.: **29/724,585**
- (22) Filed: **Feb. 18, 2020**

**Related U.S. Application Data**

- (63) Continuation-in-part of application No. 29/688,903, filed on Apr. 25, 2019, now Pat. No. Des. 927,998.
- (51) **LOC (13) Cl.** ..... **10-04**
- (52) **U.S. Cl.**  
USPC ..... **D10/70; D10/190; D10/197**
- (58) **Field of Classification Search**  
USPC ..... **D10/70; D12/190, 197**  
(Continued)

(56) **References Cited**

**U.S. PATENT DOCUMENTS**

D328,436 S 8/1992 Fuerst et al.  
5,945,907 A 8/1999 Yaron et al.  
(Continued)

**FOREIGN PATENT DOCUMENTS**

JP 1638298 S 8/2019  
JP 1638299 S 8/2019  
(Continued)

**OTHER PUBLICATIONS**

IFM Electronic, published Feb. 15, 2017.  
“Automotive Report,” Nikkei Automotive, published Oct. 11, 2018, issue 92, p. 17.

*Primary Examiner* — Antoine Duval Davis  
(74) *Attorney, Agent, or Firm* — Banner & Witcoff, Ltd.

(57) **CLAIM**

The ornamental design for a front sensor housing, as shown and described.

**DESCRIPTION**

The present application is related to U.S. Design patent application Ser. No. 29/688,905, filed Apr. 25, 2019, the entire disclosures of which are incorporated by reference herein. The present application is also related to U.S. Design patent application Ser. No. 29/724,589, entitled Rear Sensor Housing, filed concurrently herewith, the entire disclosure of which is incorporated by reference herein.

FIG. 1 is a front perspective view of a front sensor housing according to a first embodiment of our design;  
FIG. 2 is a front elevation view thereof;  
FIG. 3 is a right side elevation view thereof;  
FIG. 4 is a left side elevation view thereof;  
FIG. 5 is a top plan view thereof;  
FIG. 6 is a front perspective view of a front sensor housing according to a second embodiment of our design;  
FIG. 7 is a front elevation view thereof;  
FIG. 8 is a right side elevation view thereof;  
FIG. 9 is a left side elevation view thereof;  
FIG. 10 is a top plan view thereof;  
FIG. 11 is a front perspective view of a front sensor housing according to a third embodiment of our design;  
FIG. 12 is a front elevation view thereof;  
FIG. 13 is a right side elevation view thereof;  
FIG. 14 is a left side elevation view thereof;  
FIG. 15 is a top plan view thereof;  
FIG. 16 is a front perspective view of a front sensor housing according to a fourth embodiment of our design;  
FIG. 17 is a front elevation view thereof;  
FIG. 18 is a right side elevation view thereof;

(Continued)

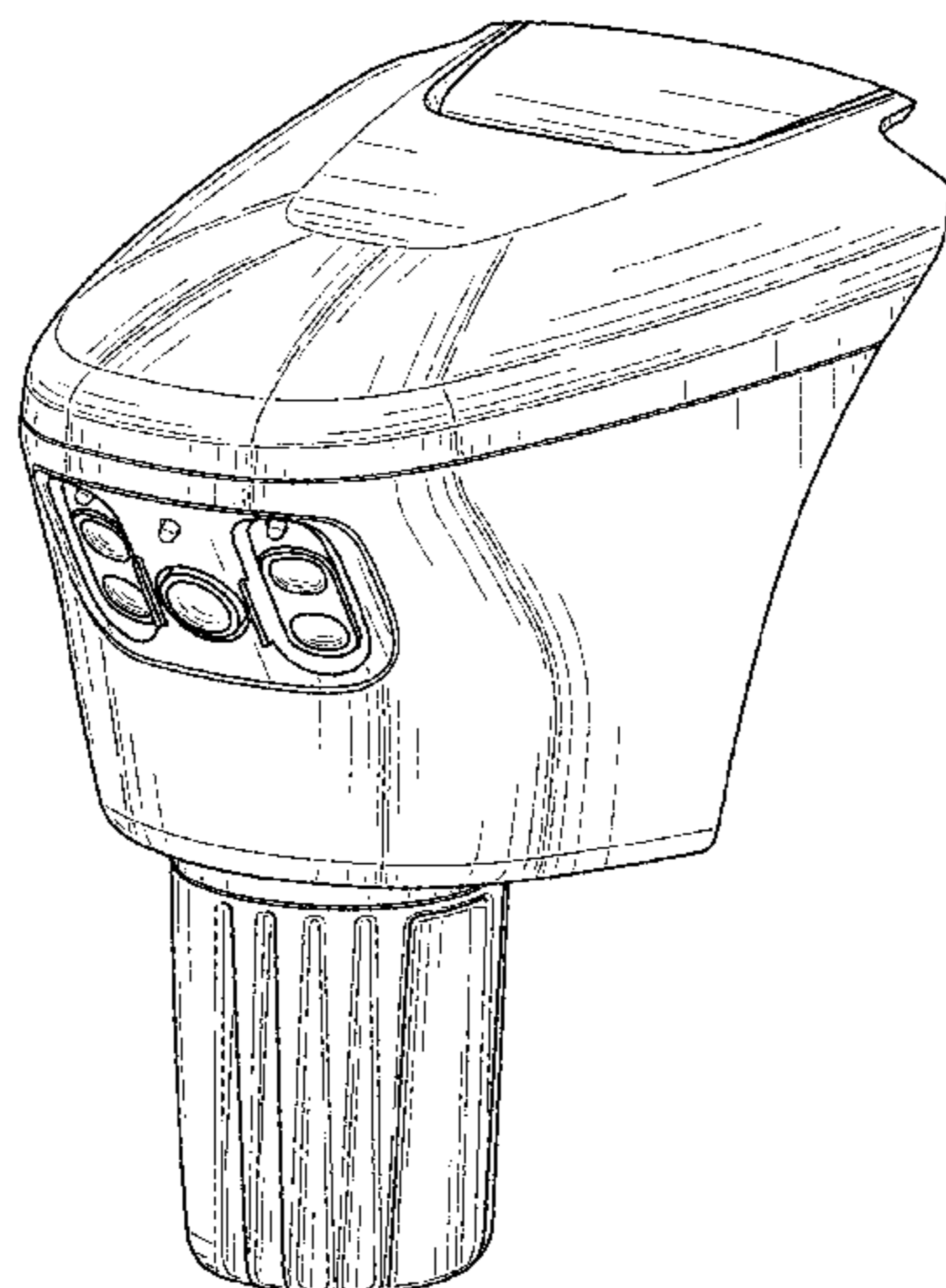

FIG. 19 is a left side elevation view thereof;  
 FIG. 20 is a top plan view thereof;  
 FIG. 21 is a front perspective view of a front sensor housing according to a fifth embodiment of our design;  
 FIG. 22 is a front elevation view thereof;  
 FIG. 23 is a right side elevation view thereof;  
 FIG. 24 is a left side elevation view thereof; and,  
 FIG. 25 is a top plan view thereof.  
 The broken lines in the figures illustrate portions of the front sensor housing that form no part of the claimed design.

**1 Claim, 20 Drawing Sheets**

(58) **Field of Classification Search**

CPC .. B60Q 1/0017; B60Q 1/0023; B60Q 1/0029;  
 B60Q 1/0035; B60Q 1/0041; B60Q 1/26;  
 B60Q 1/2603; B60Q 1/2607; B60Q  
 1/2611; B60Q 9/002; B60Q 9/003; B60Q  
 9/004; B60Q 9/006; B60Q 9/007; B60Q  
 9/008; B60R 1/10; B60R 1/12; B60R  
 2001/1284; G05D 1/0055; G05D 1/021;  
 G05D 1/0212; G05D 1/0016; G05D  
 1/0088; G05D 1/02; G05D 2201/0212;  
 B60K 37/06; B60K 35/00; B60K 28/02;  
 B60K 2370/128; B60K 2370/682; B60K  
 2370/175; B60K 2370/12; B60K  
 2370/122; B60K 2370/143; B60W  
 50/082; B60W 30/06; B60W 2540/215;  
 B62D 15/0285; B60Y 2302/05; G08B  
 25/016

See application file for complete search history.

(56)

**References Cited**

U.S. PATENT DOCUMENTS

D478,518 S	8/2003	Porter	
D525,888 S	8/2006	Porter	
9,725,060 B1	8/2017	Daniel et al.	
9,862,311 B2	1/2018	Kiriyama et al.	
D825,357 S	8/2018	Ahn et al.	
D826,073 S	8/2018	Alkelai et al.	
D834,971 S	12/2018	Ahn et al.	
D835,028 S	12/2018	Ahn et al.	
D850,303 S	6/2019	Wang et al.	
D850,946 S	6/2019	Zhevelev et al.	
D860,013 S	9/2019	Ahn et al.	
10,444,752 B2	10/2019	Kim et al.	
D874,957 S *	2/2020	Ahn .....	D10/70
2013/0242586 A1 *	9/2013	Huizen .....	B60R 1/12 362/494
2016/0011594 A1	1/2016	Chung et al.	
2017/0151933 A1	6/2017	Doorley et al.	
2017/0293016 A1	10/2017	McCloskey et al.	
2017/0297488 A1	10/2017	Wang et al.	
2017/0300060 A1	10/2017	Crawley	
2017/0343654 A1	11/2017	Valois et al.	
2018/0011173 A1	1/2018	Newman	
2018/0015886 A1	1/2018	Frank et al.	
2018/0017680 A1	1/2018	Pennecot et al.	
2018/0037268 A1	2/2018	Moore et al.	
2018/0086280 A1	3/2018	Nguyen	
2020/0195816 A1	6/2020	Stein et al.	

FOREIGN PATENT DOCUMENTS

KR	101998298 B1	7/2019
WO	2018138584 A1	8/2018

\* cited by examiner

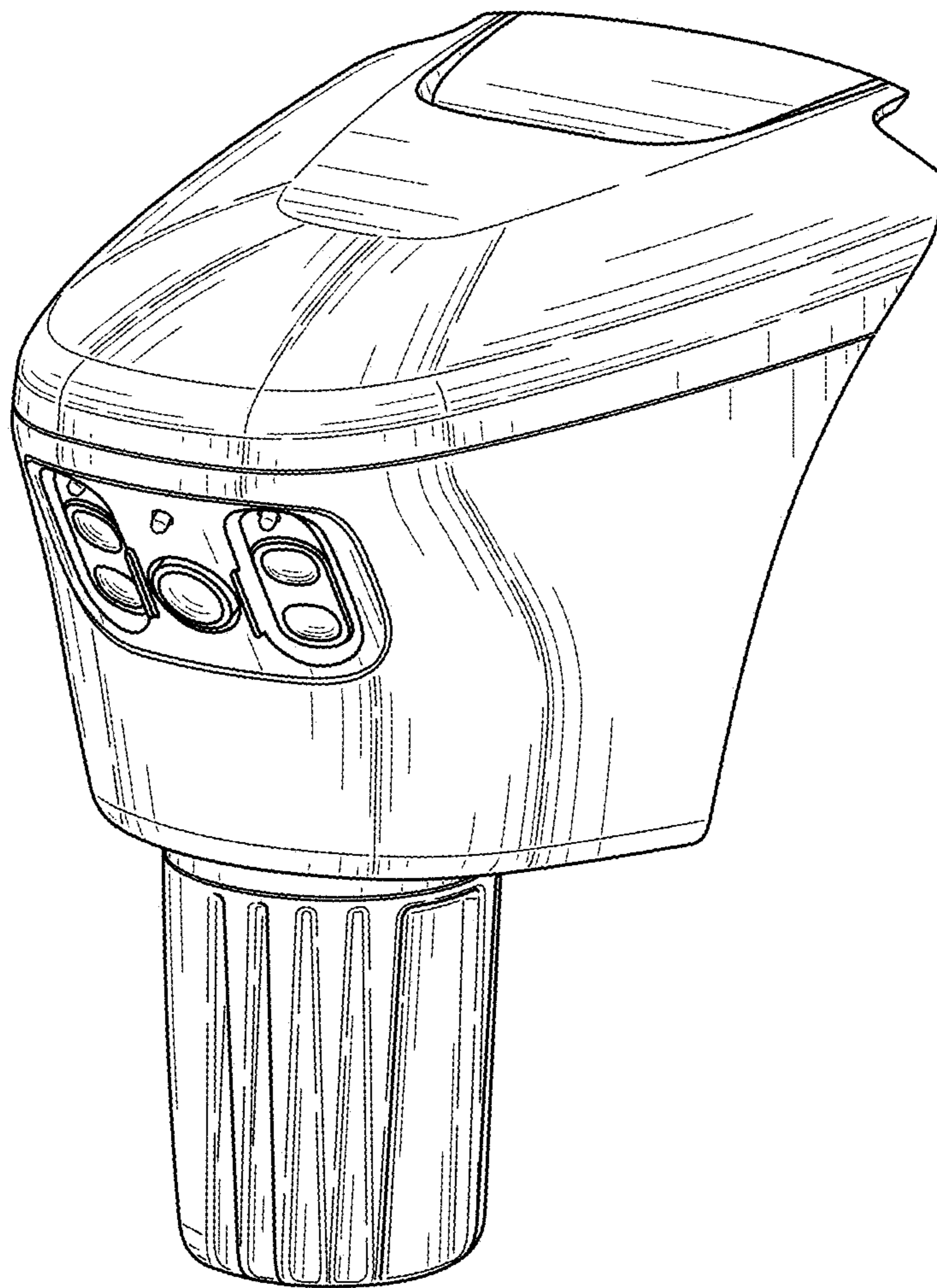

FIG. 1

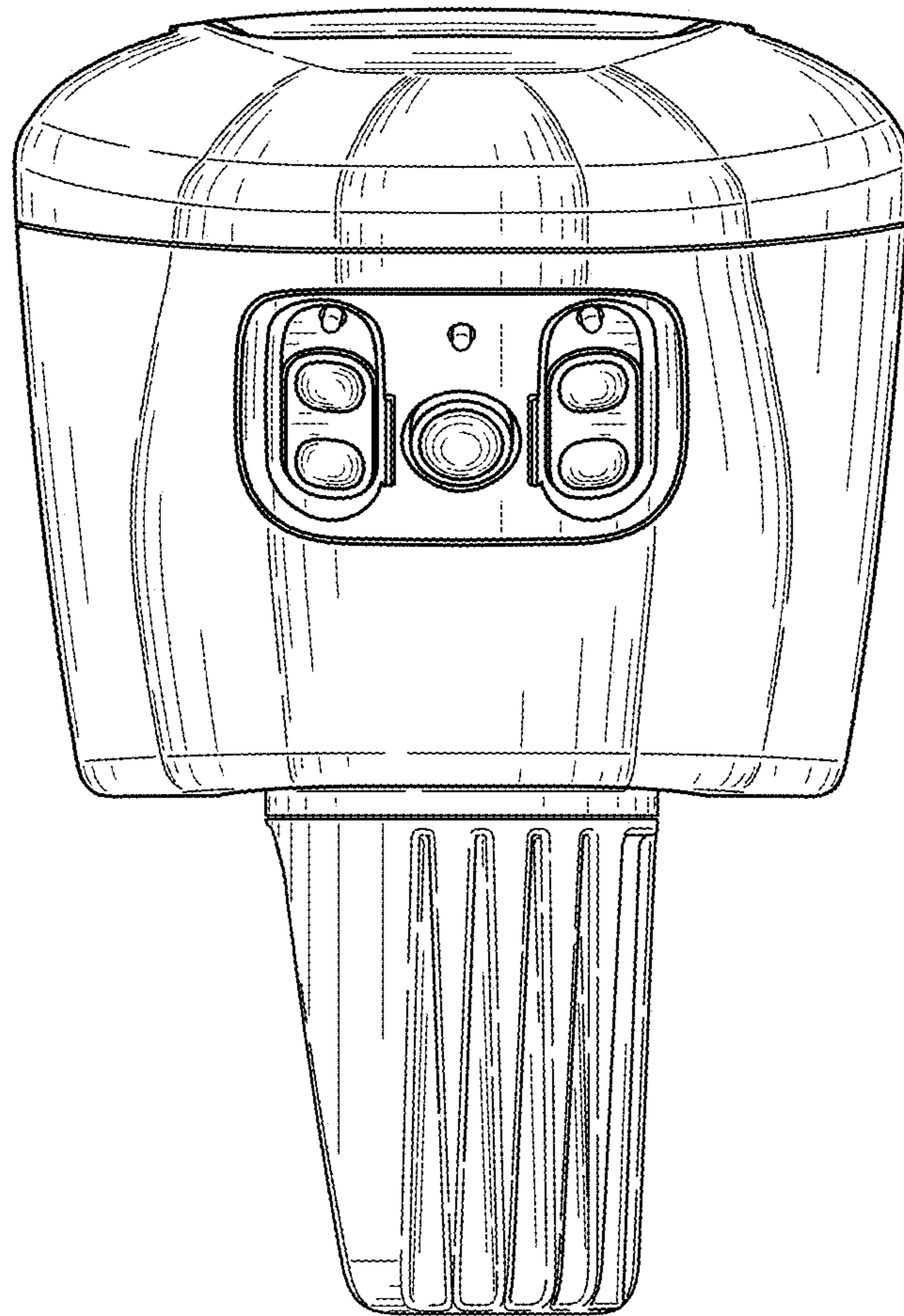

FIG. 2

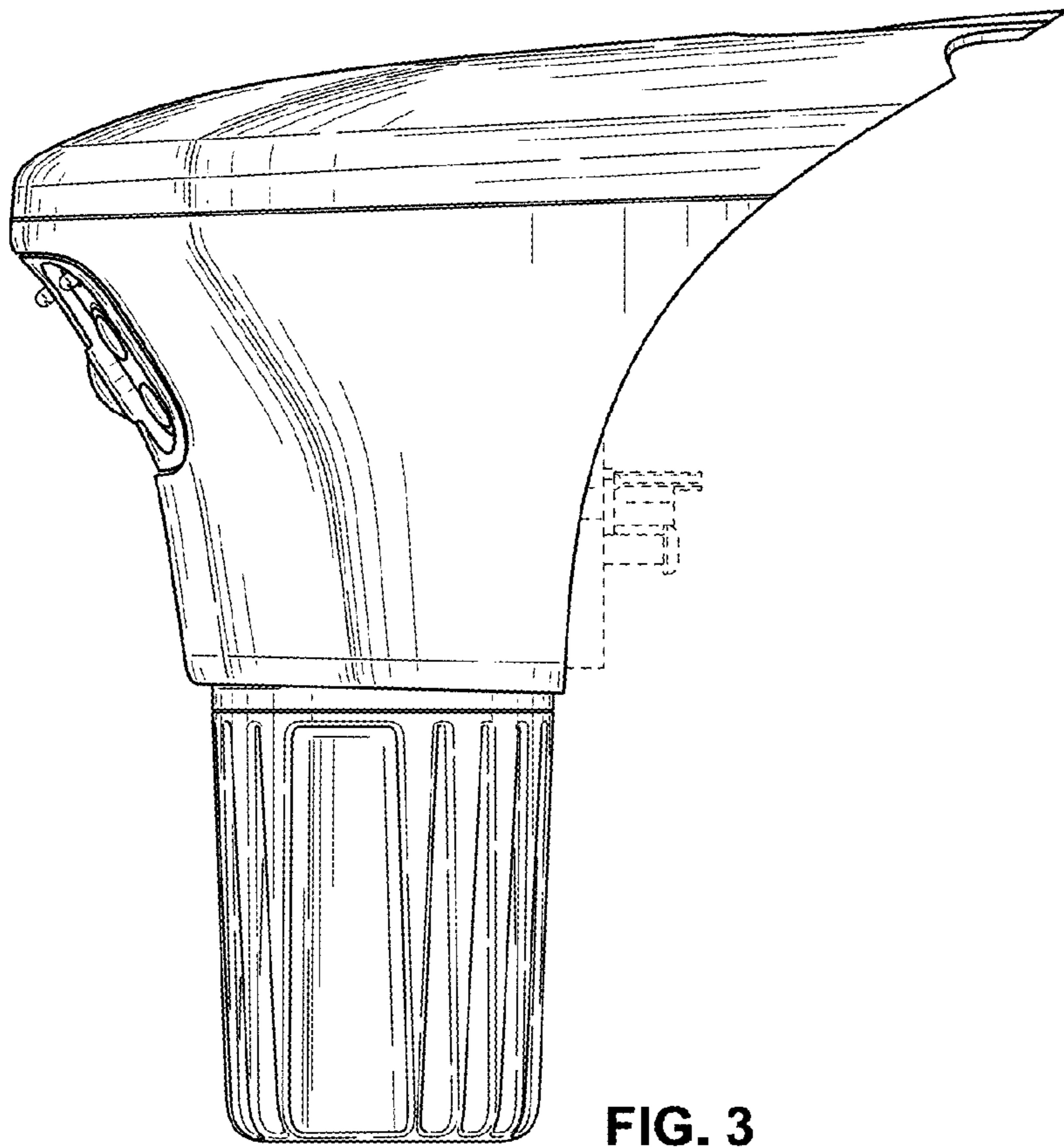

FIG. 3

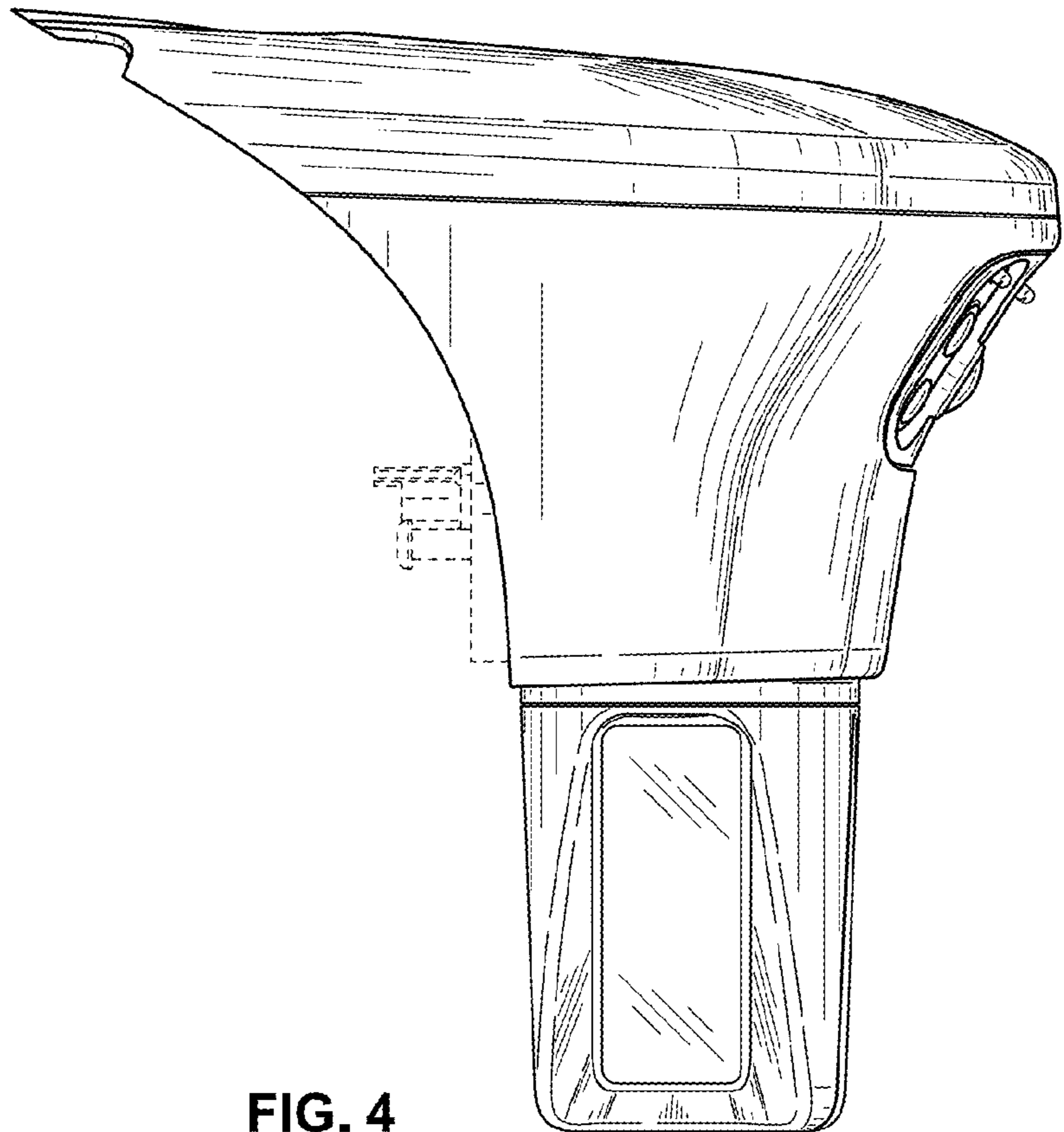

FIG. 4

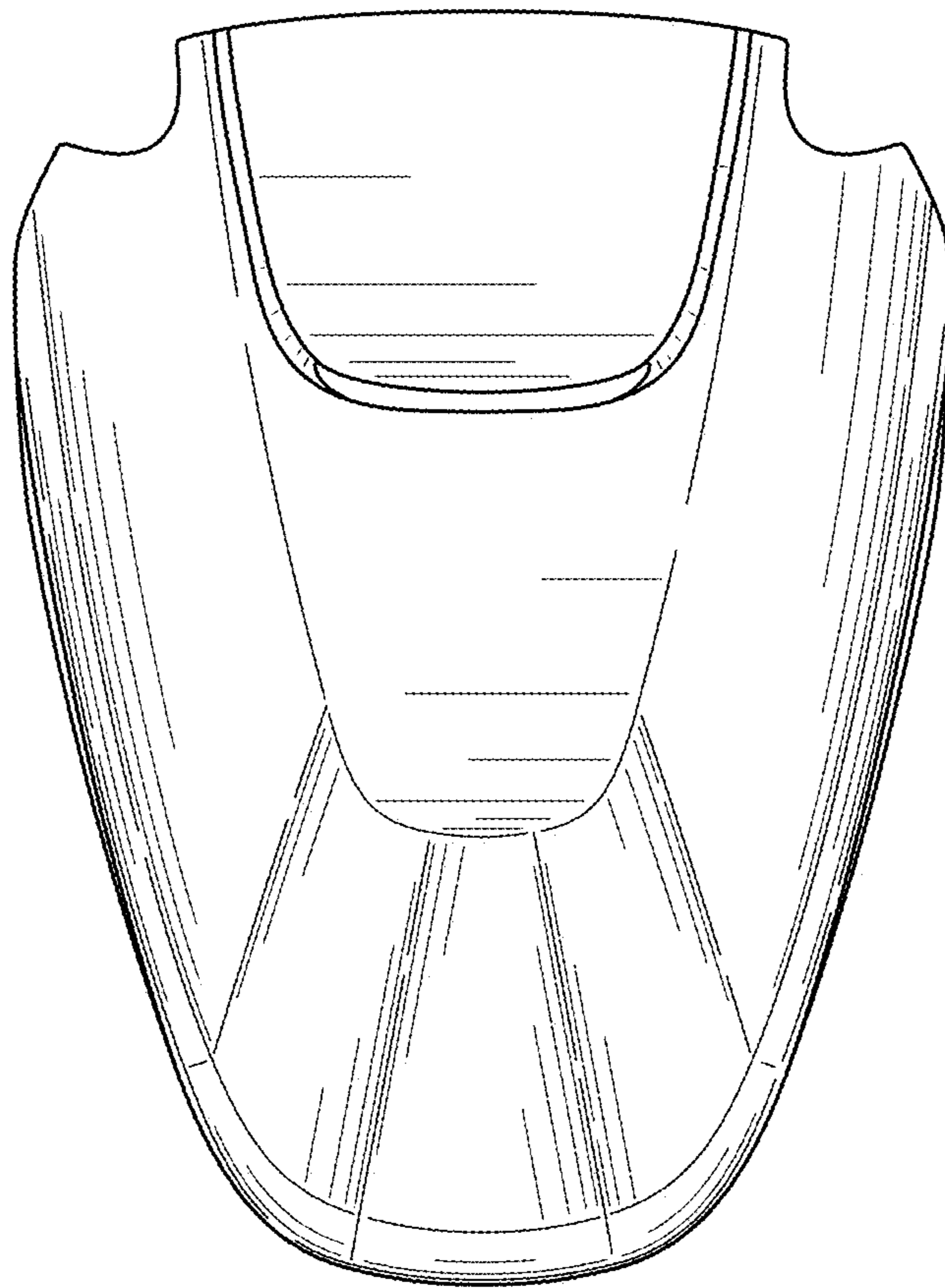

FIG. 5

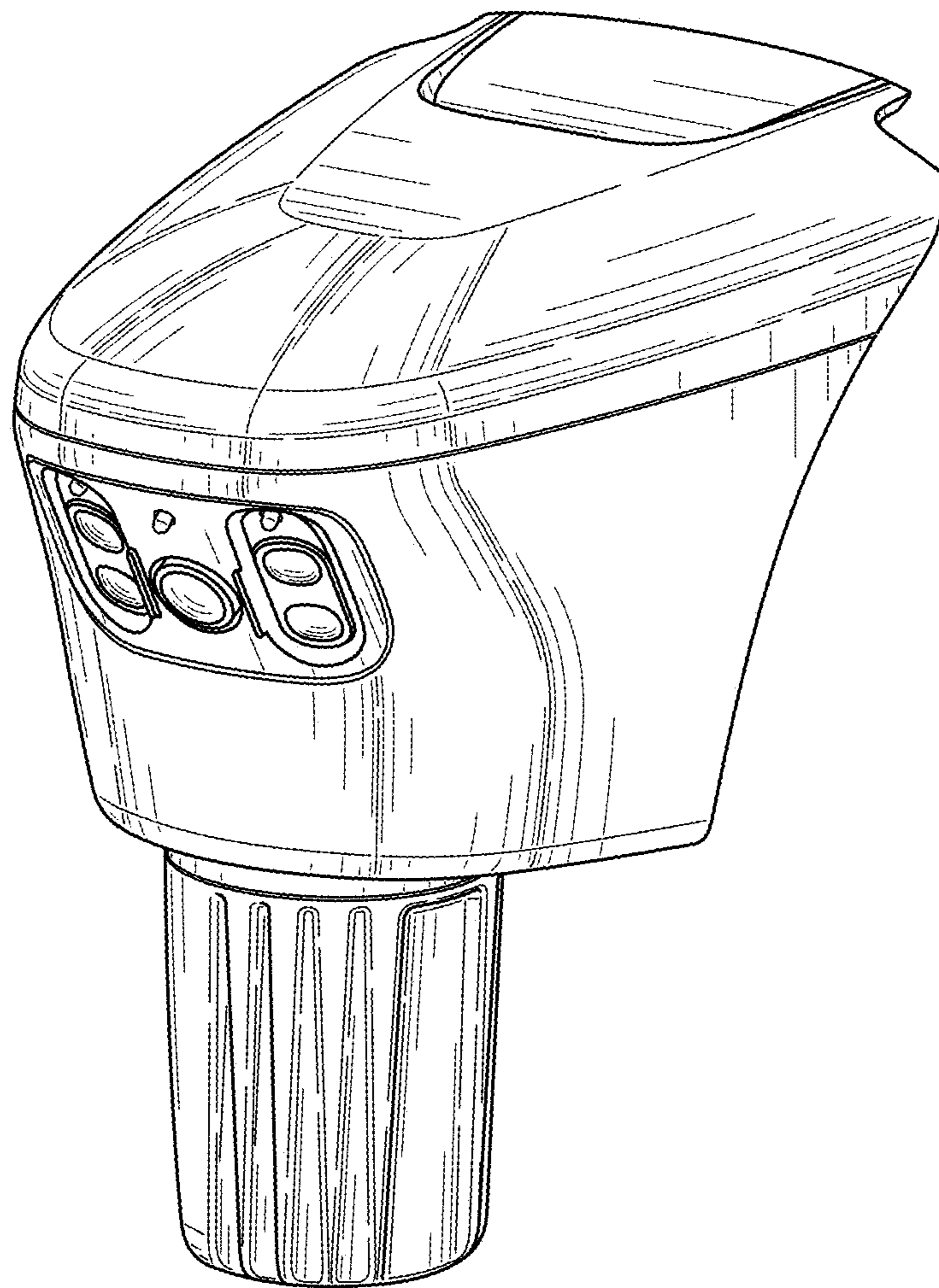

FIG. 6

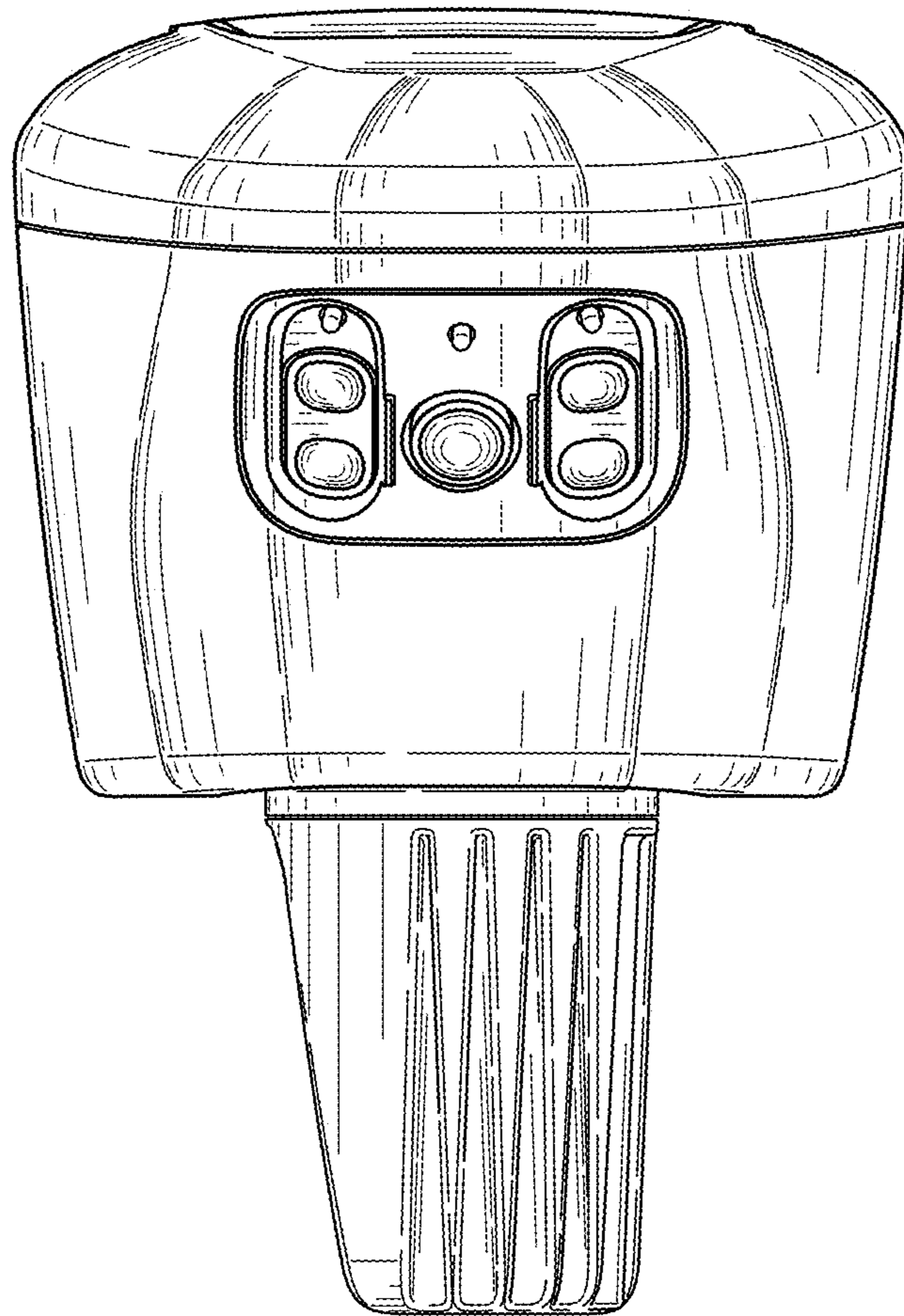
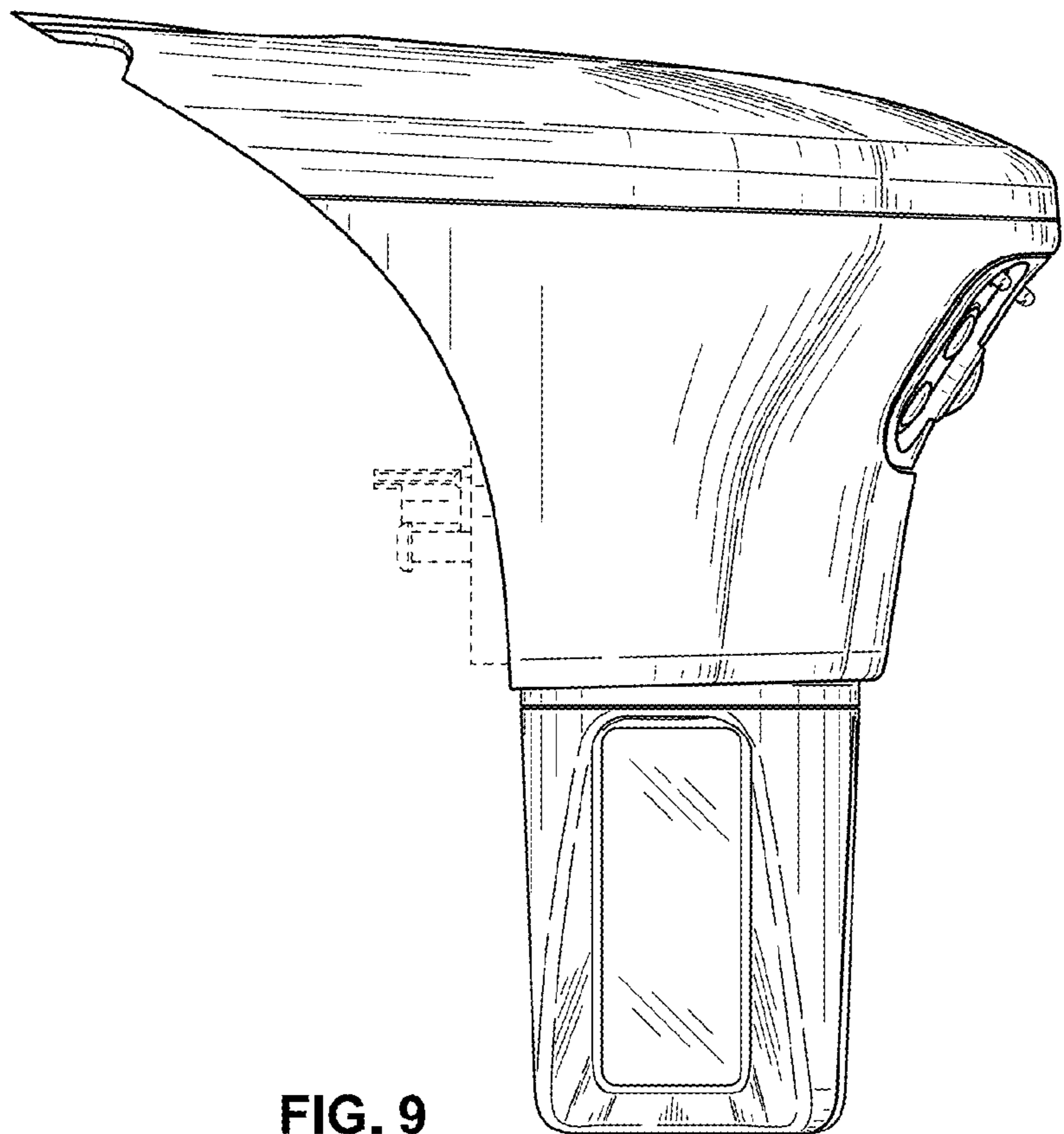
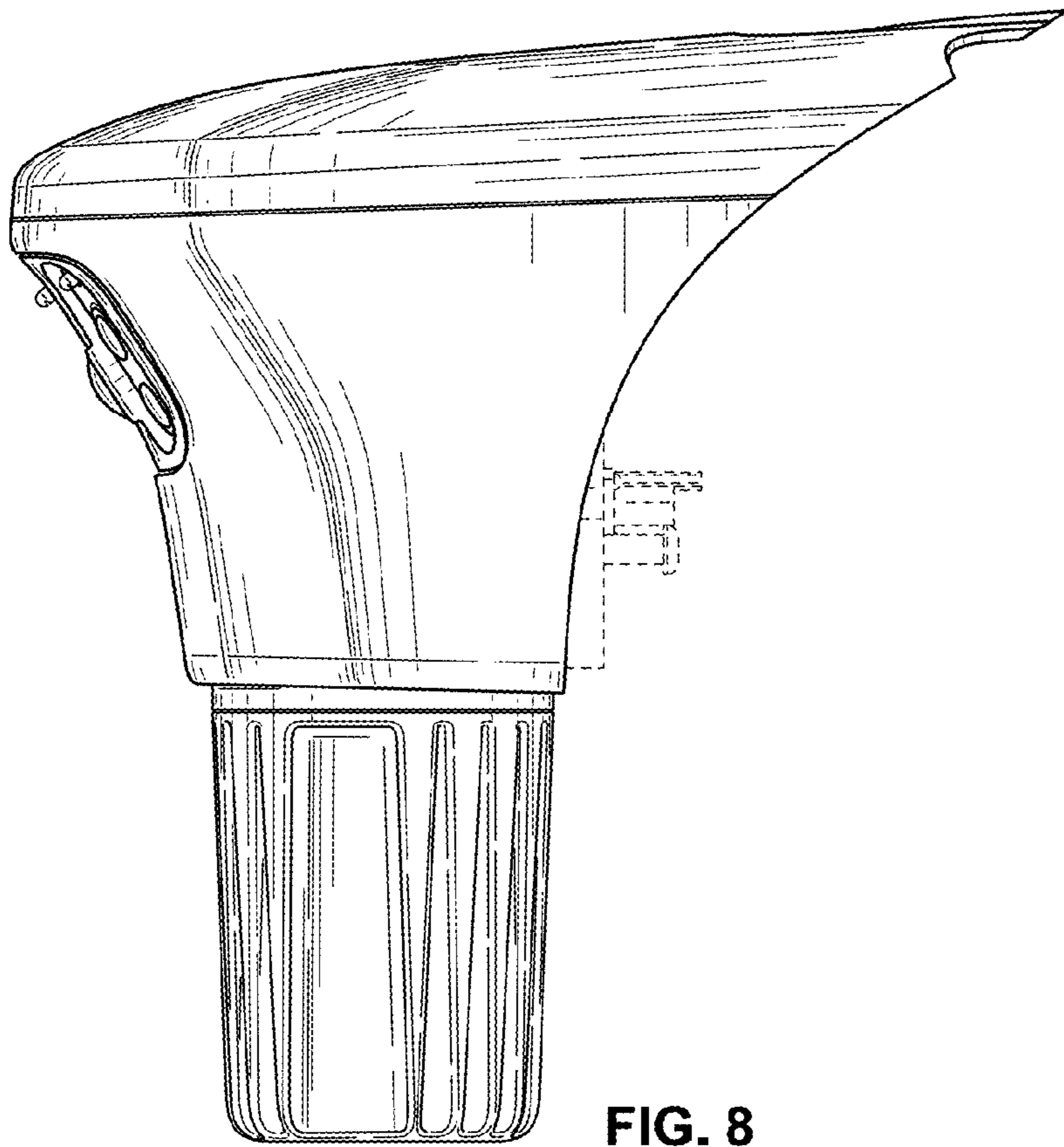

FIG. 7





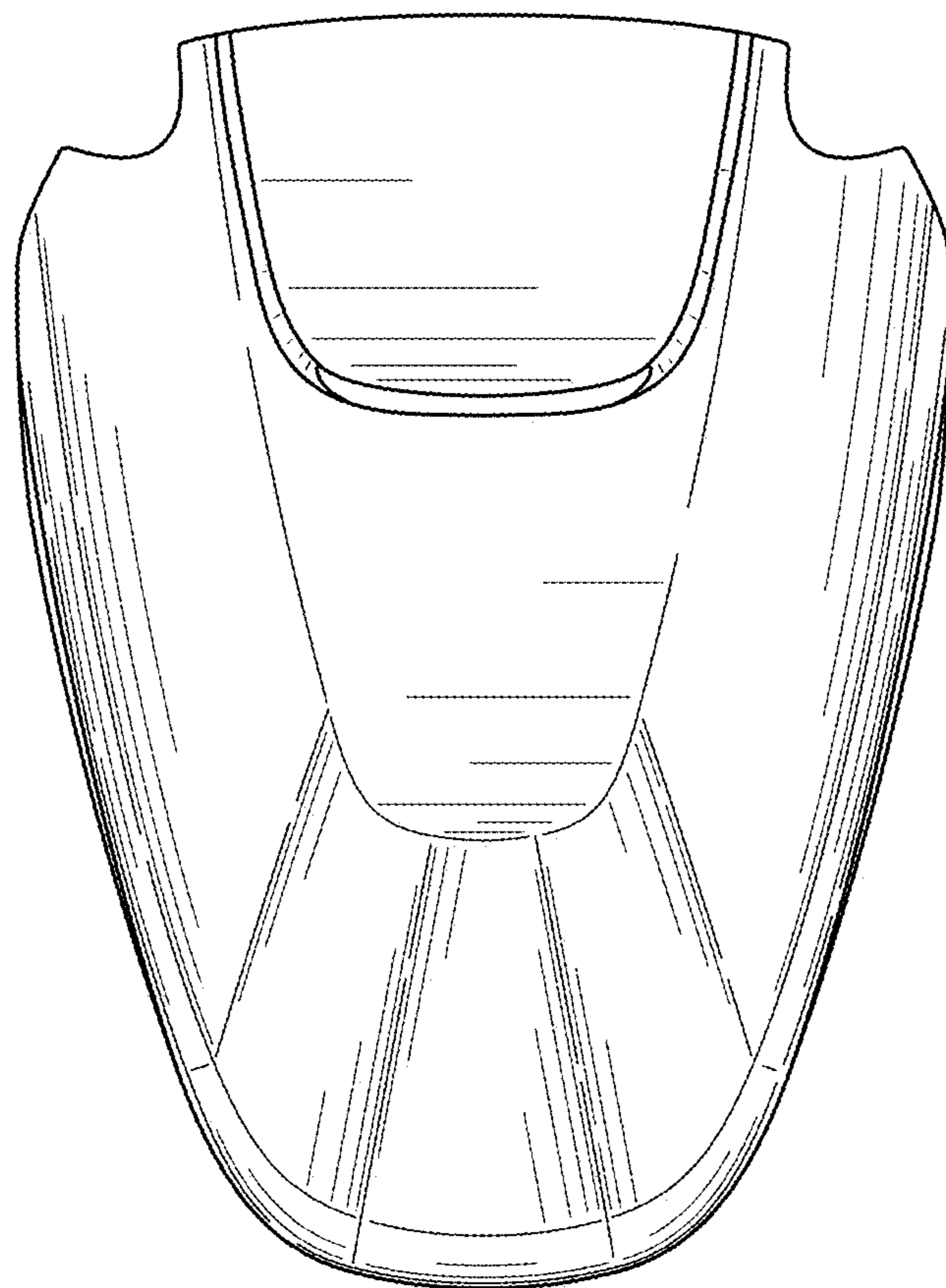

FIG. 10

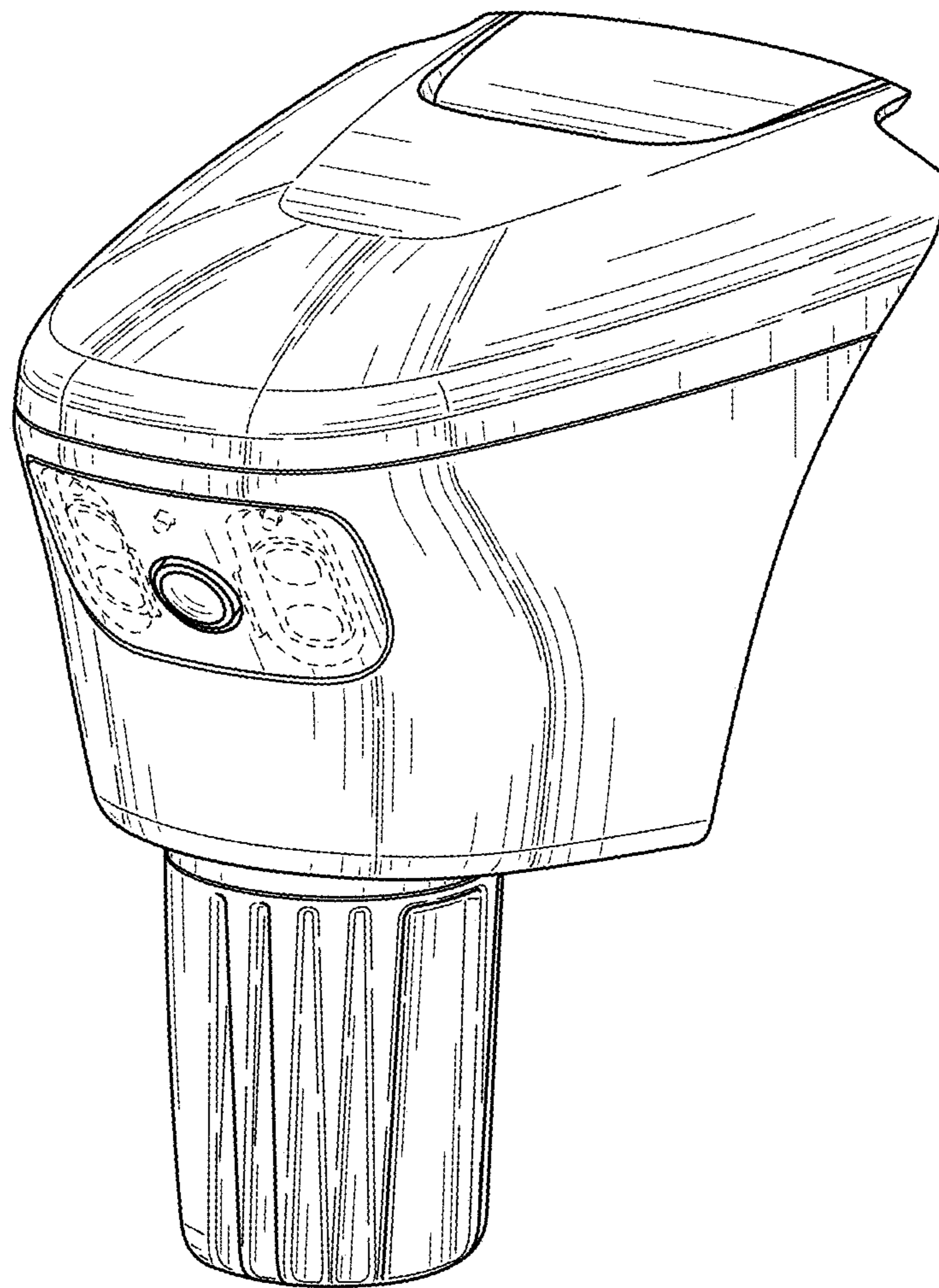

FIG. 11

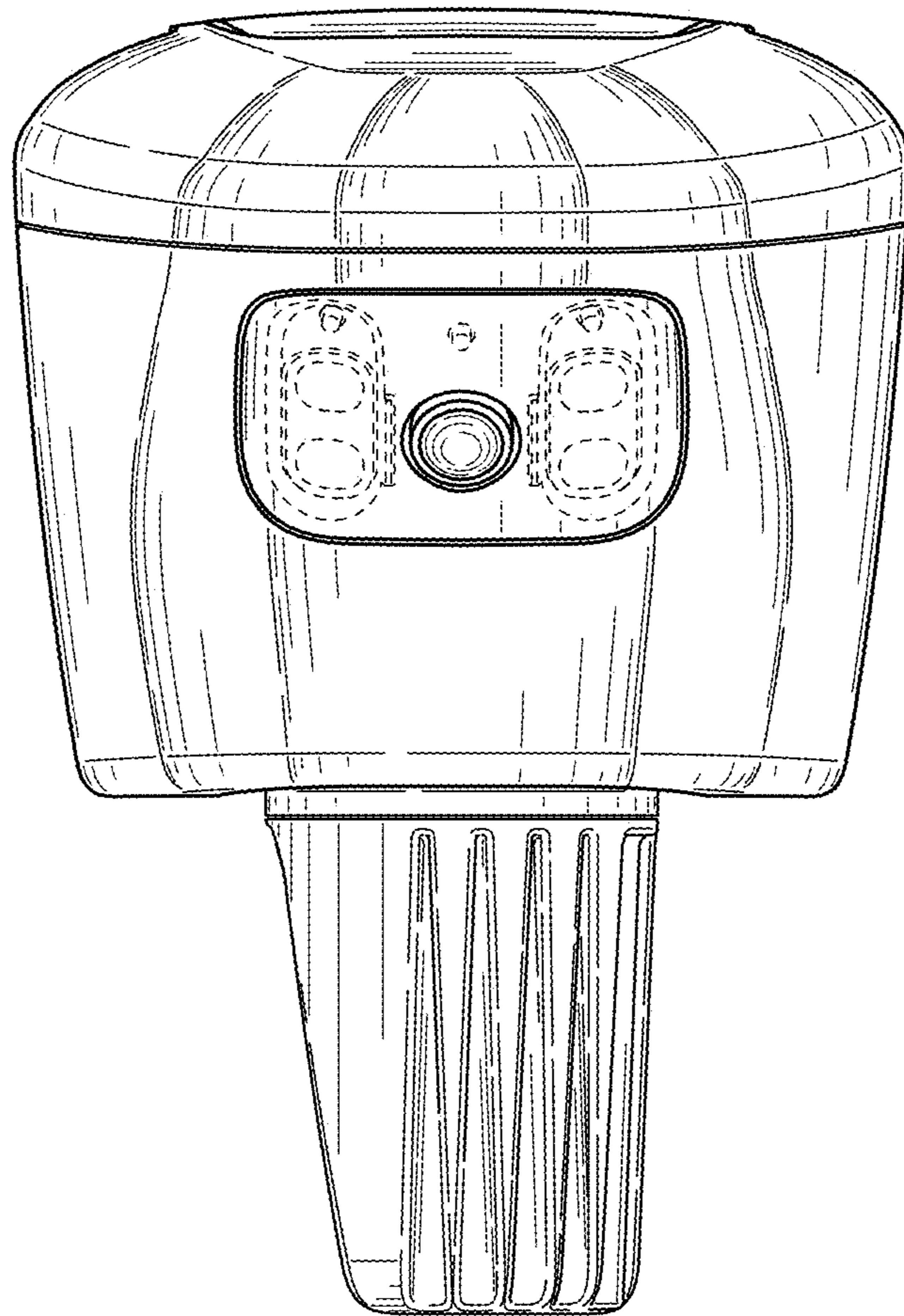

FIG. 12

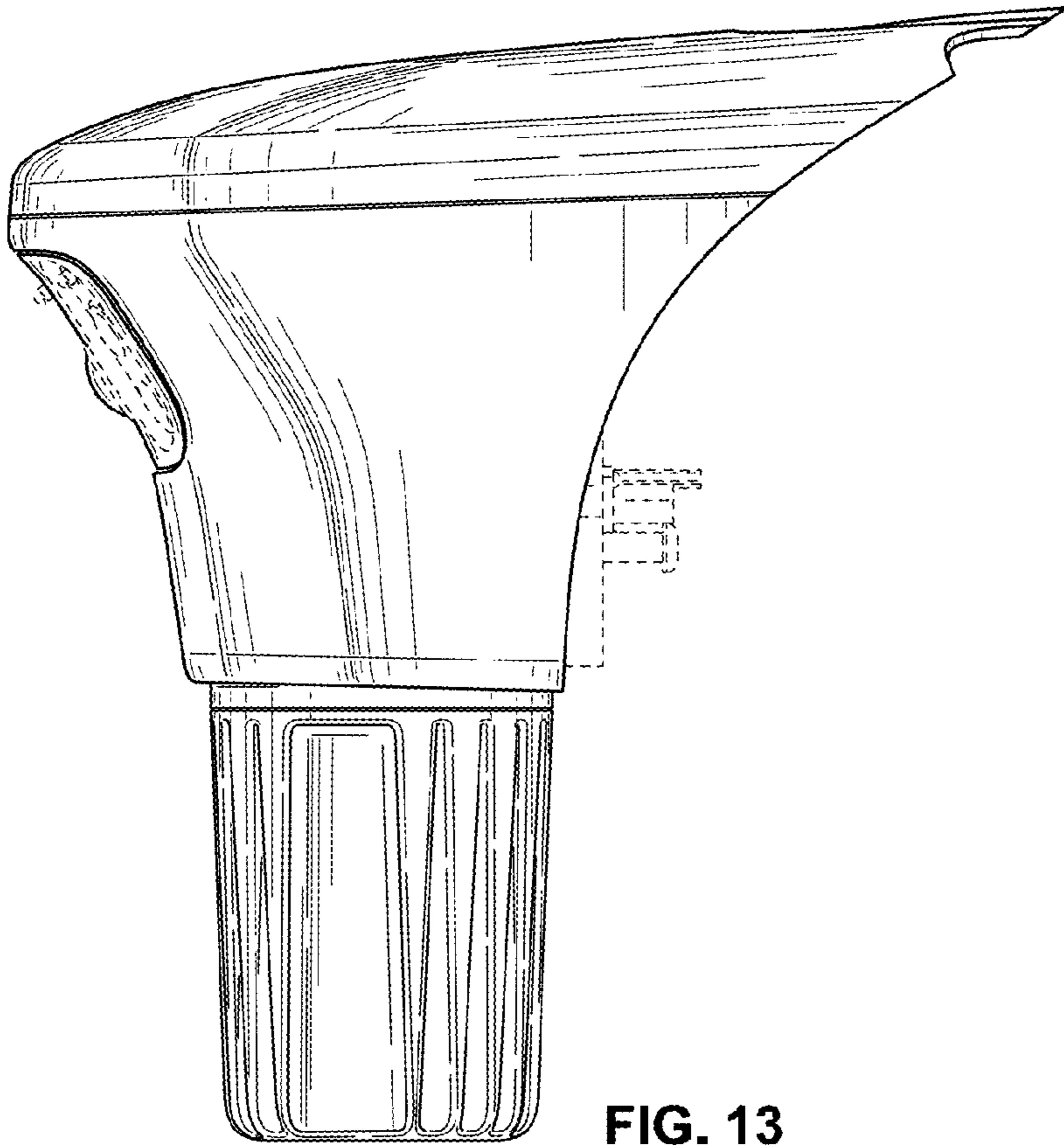

FIG. 13

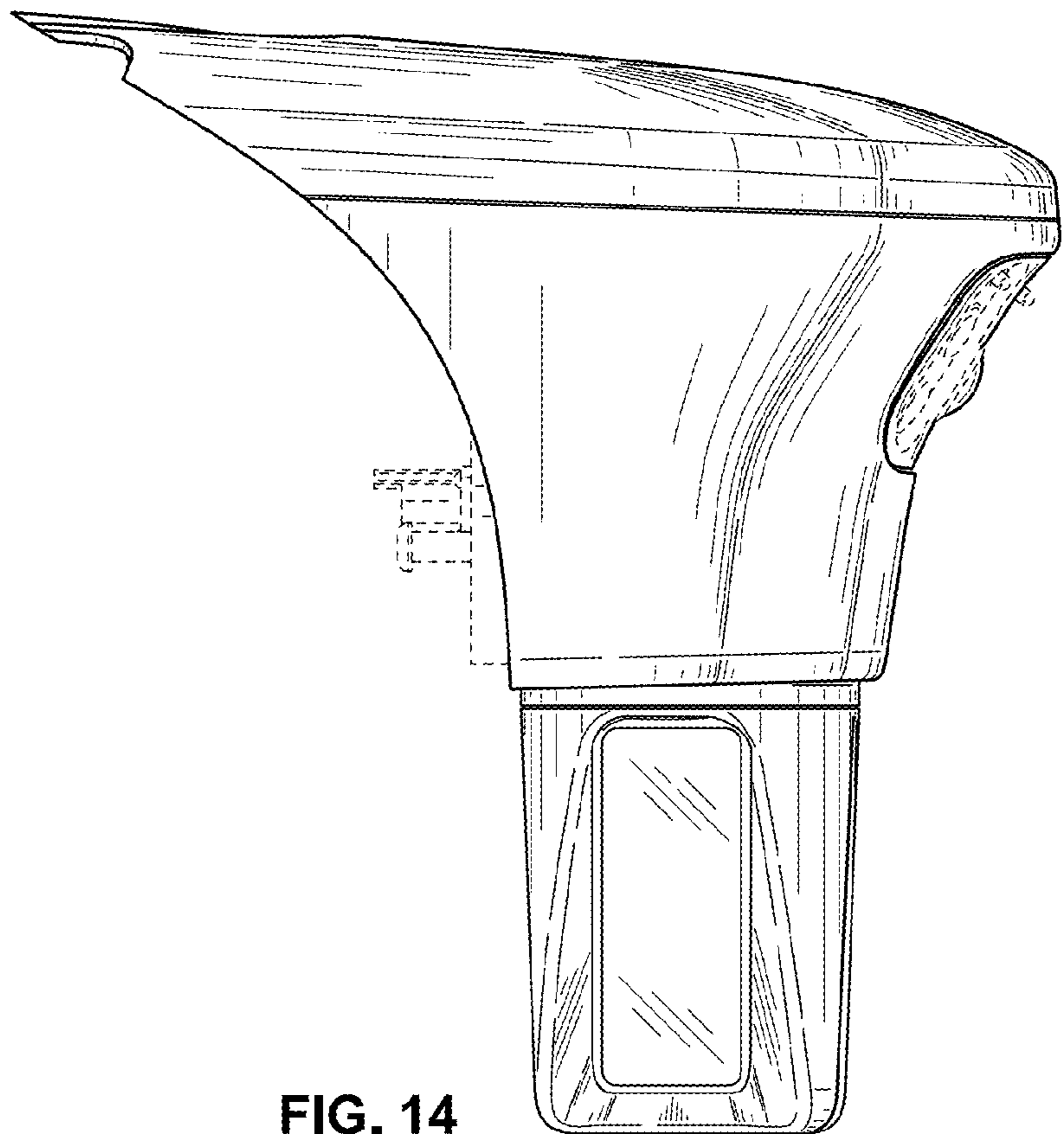

FIG. 14

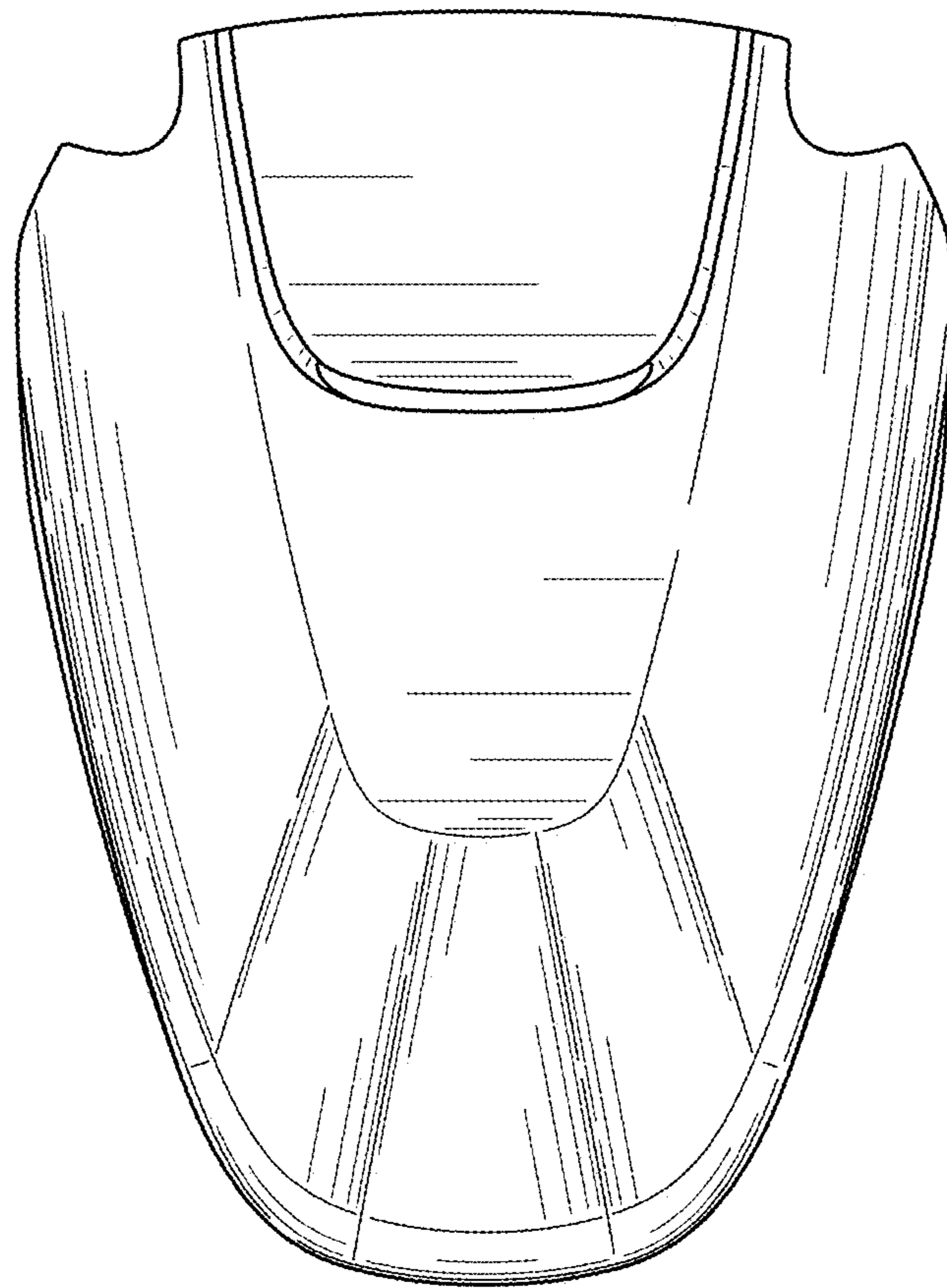

FIG. 15

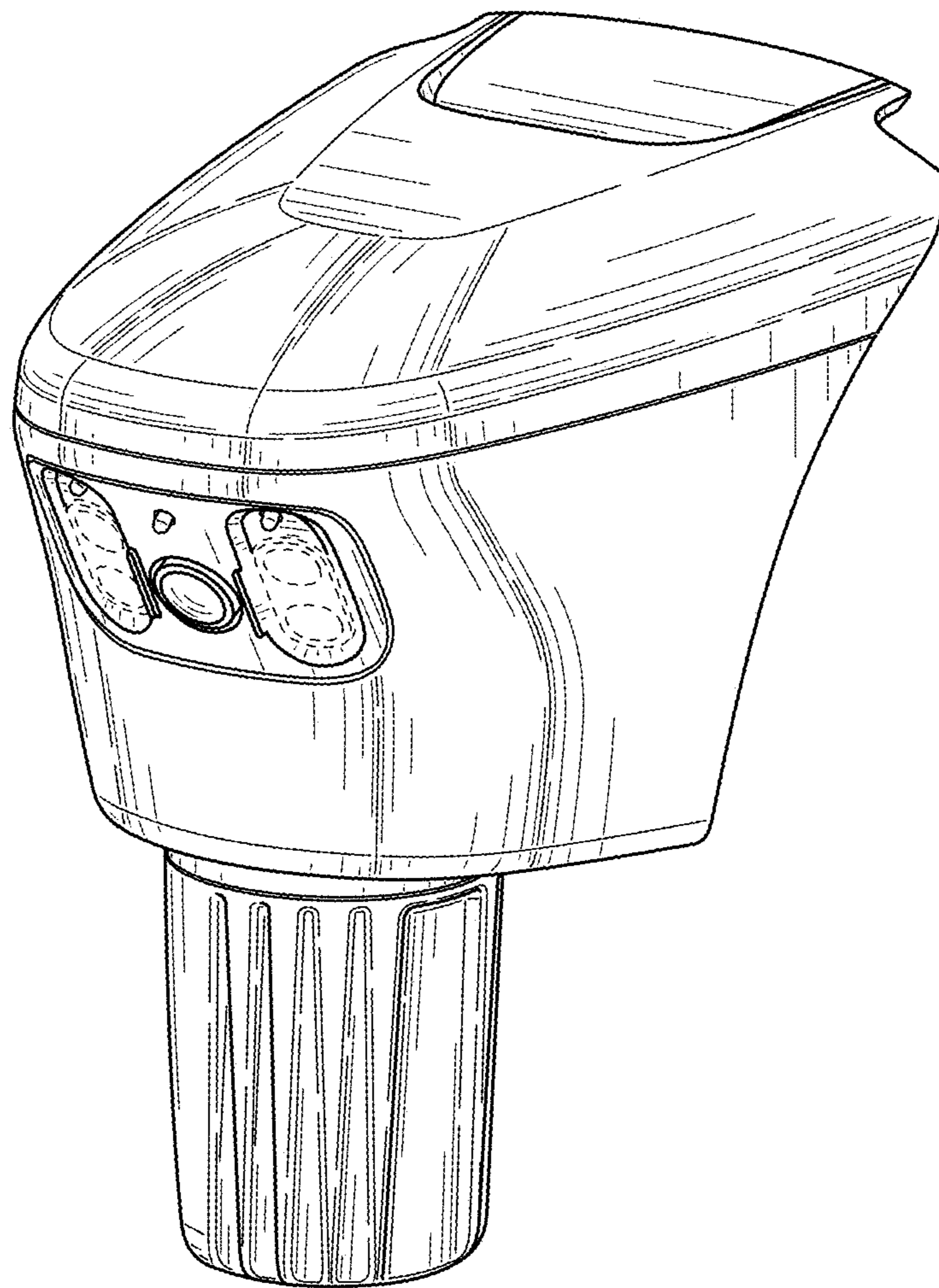

FIG. 16

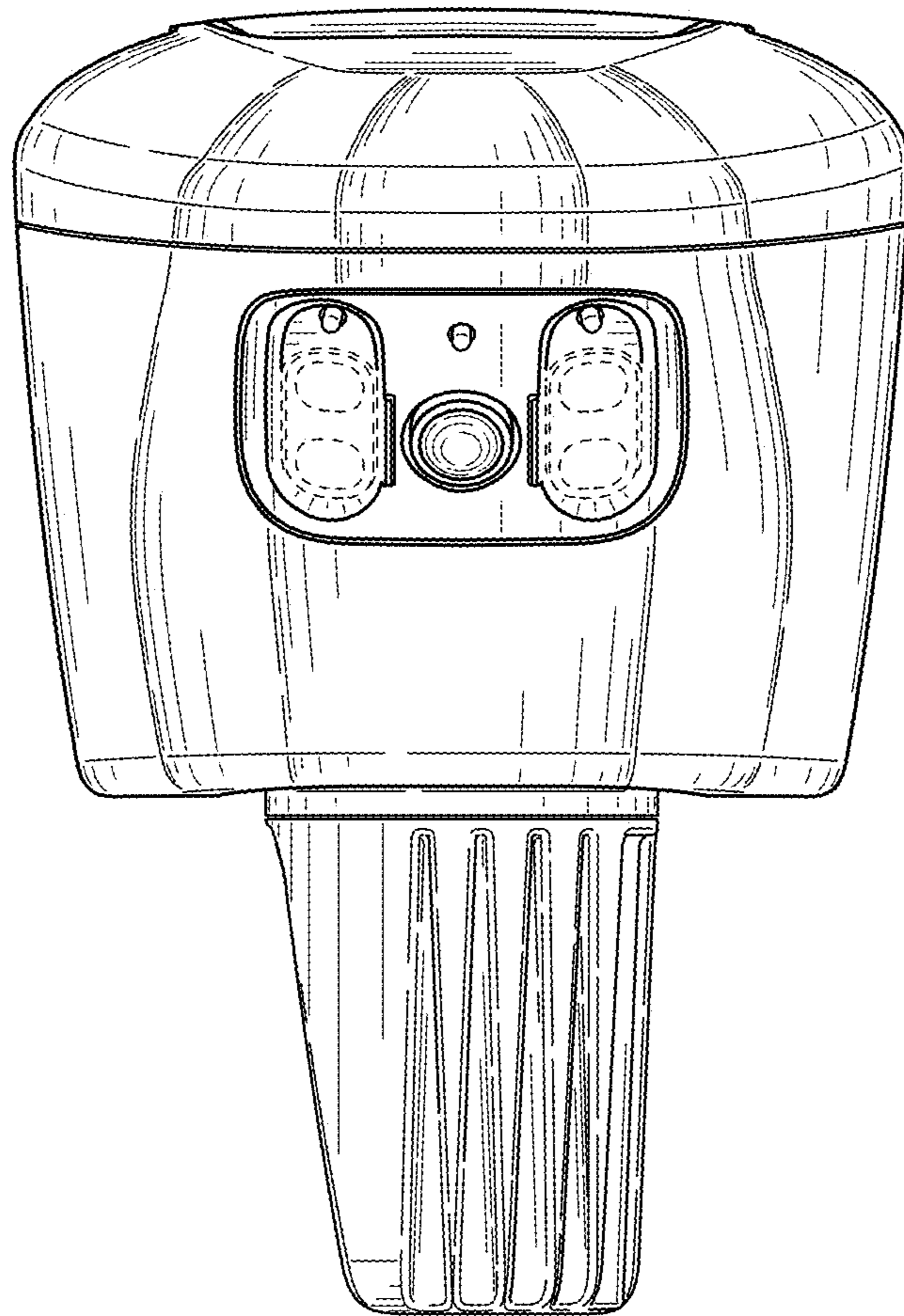

FIG. 17



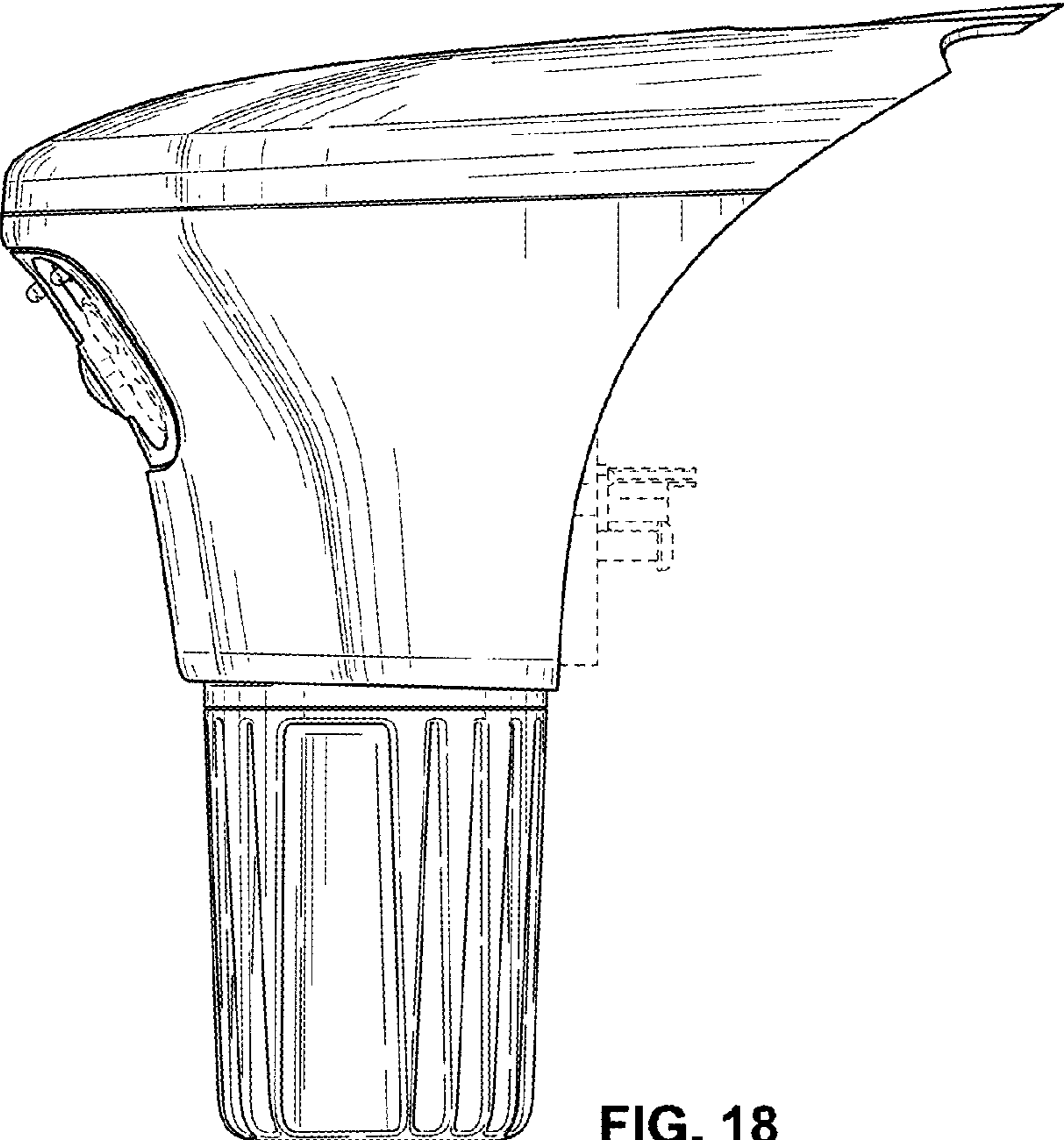

FIG. 18

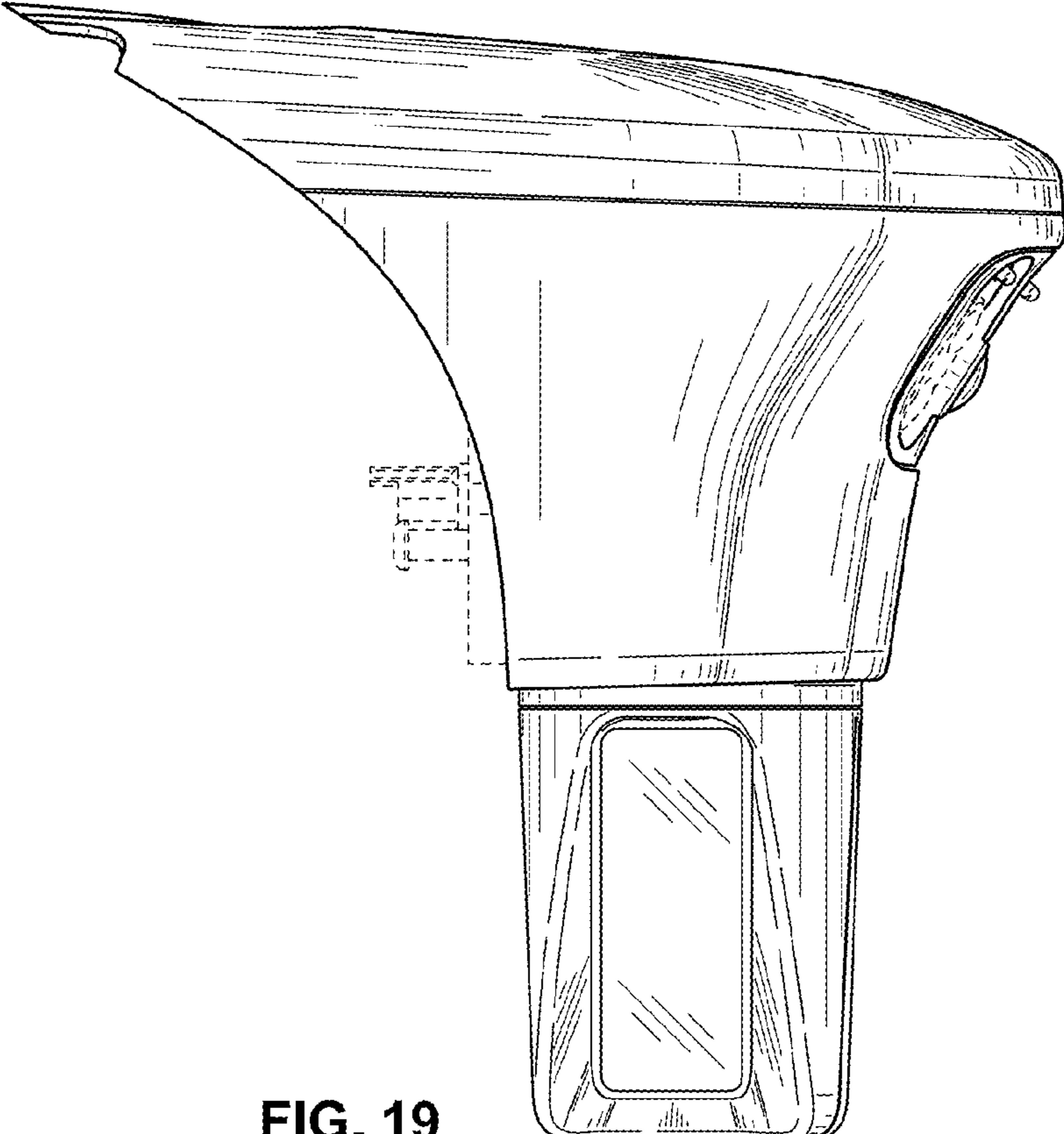

FIG. 19

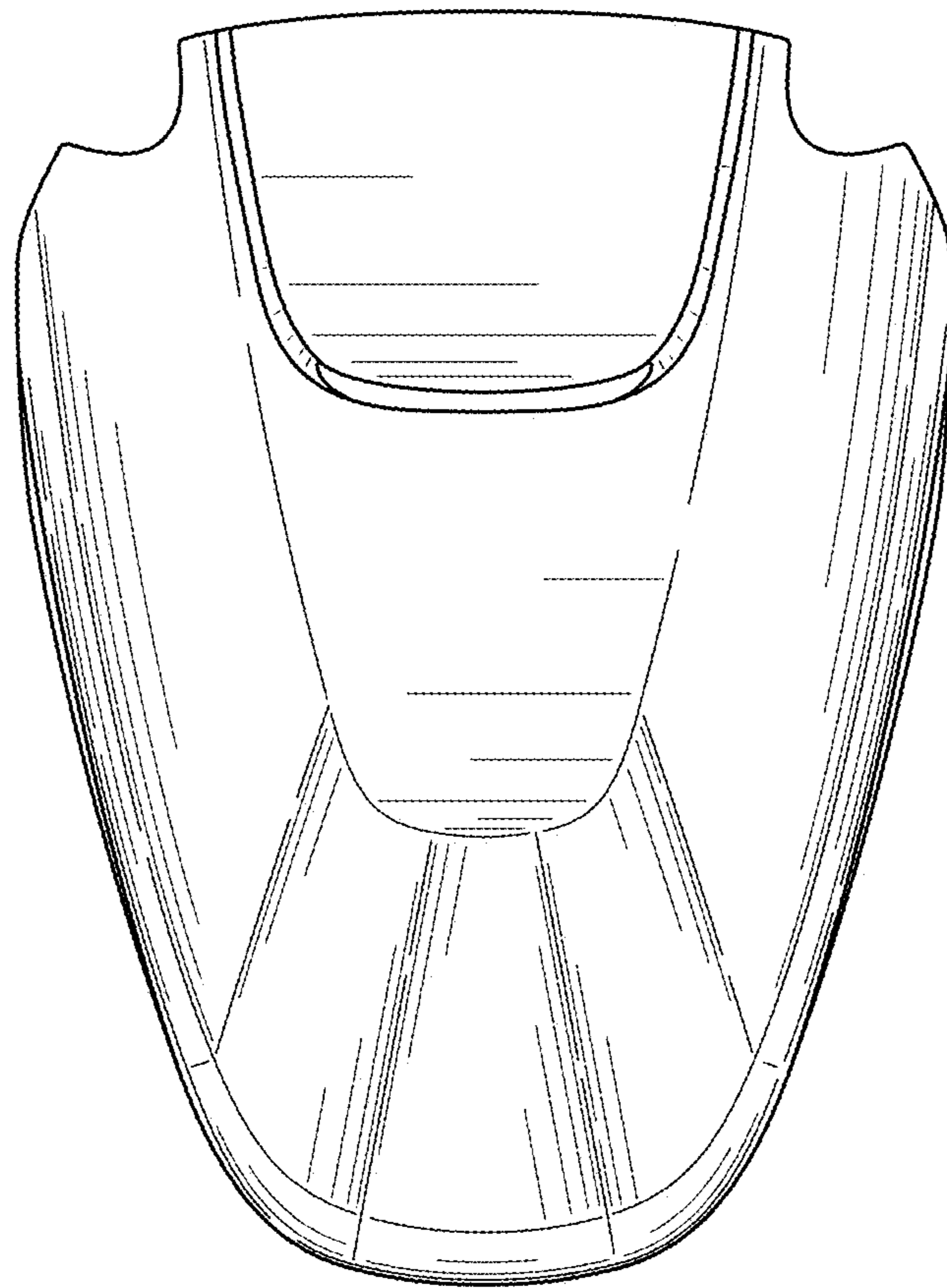

FIG. 20

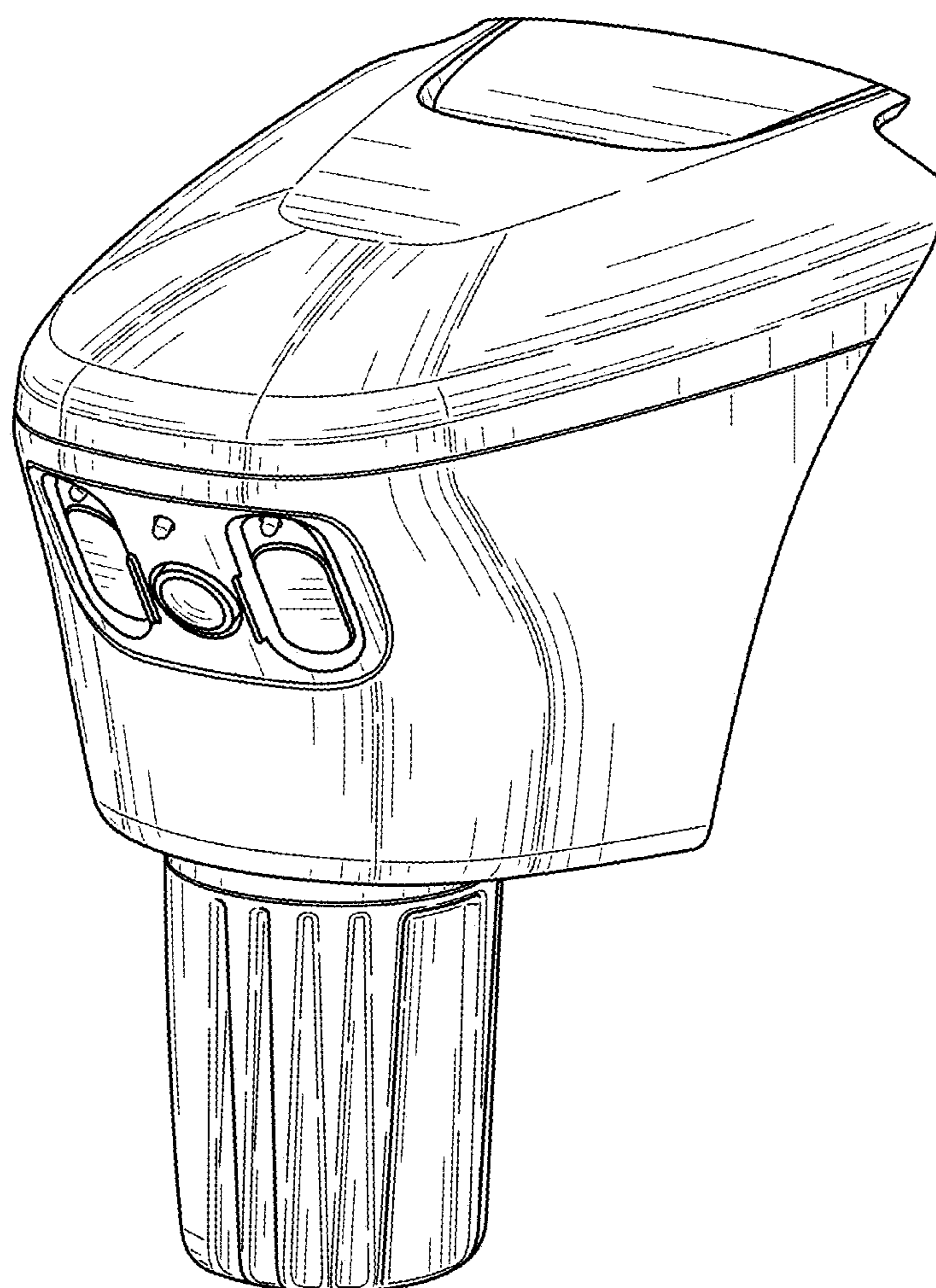

FIG. 21

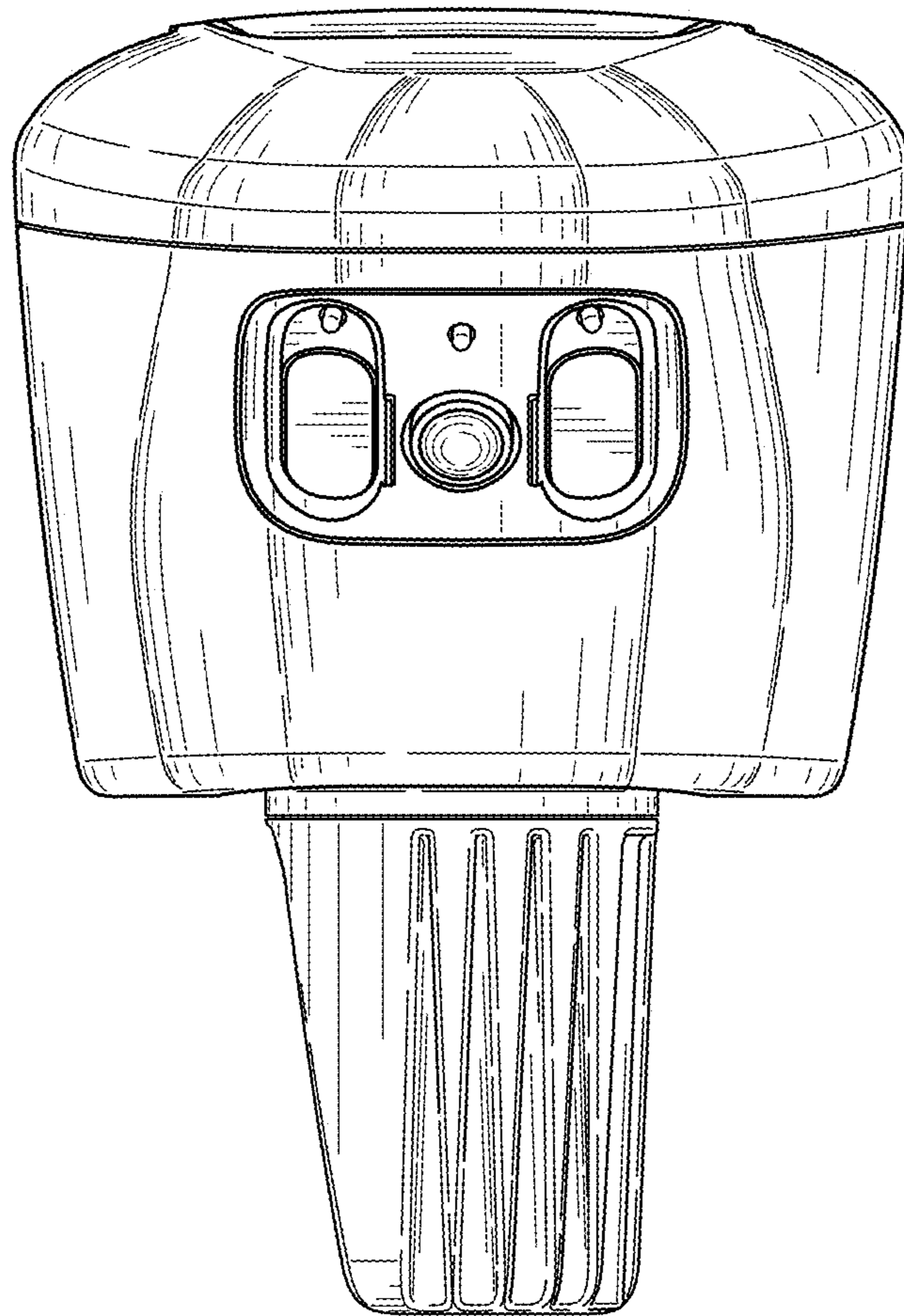

FIG. 22

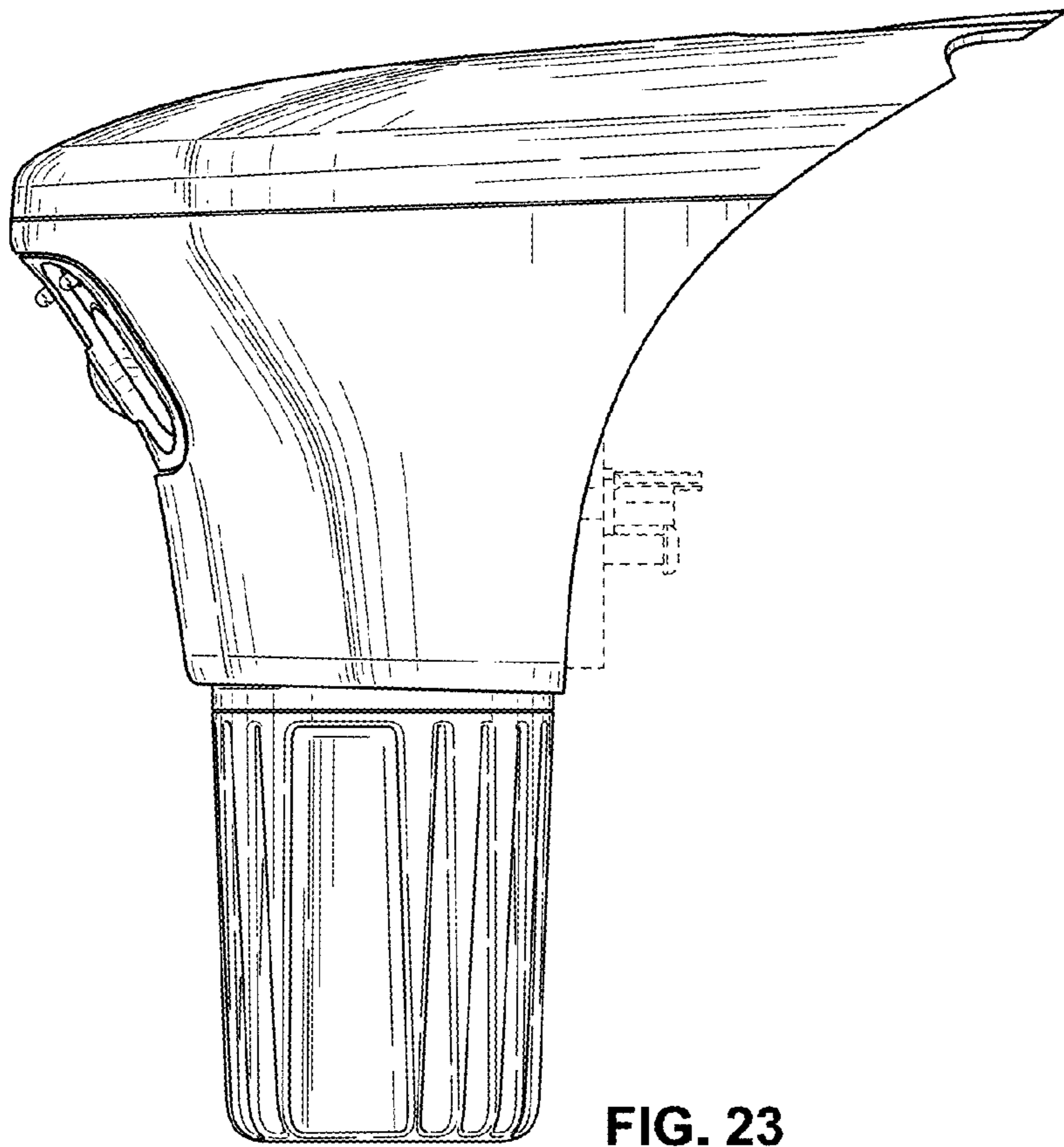

FIG. 23

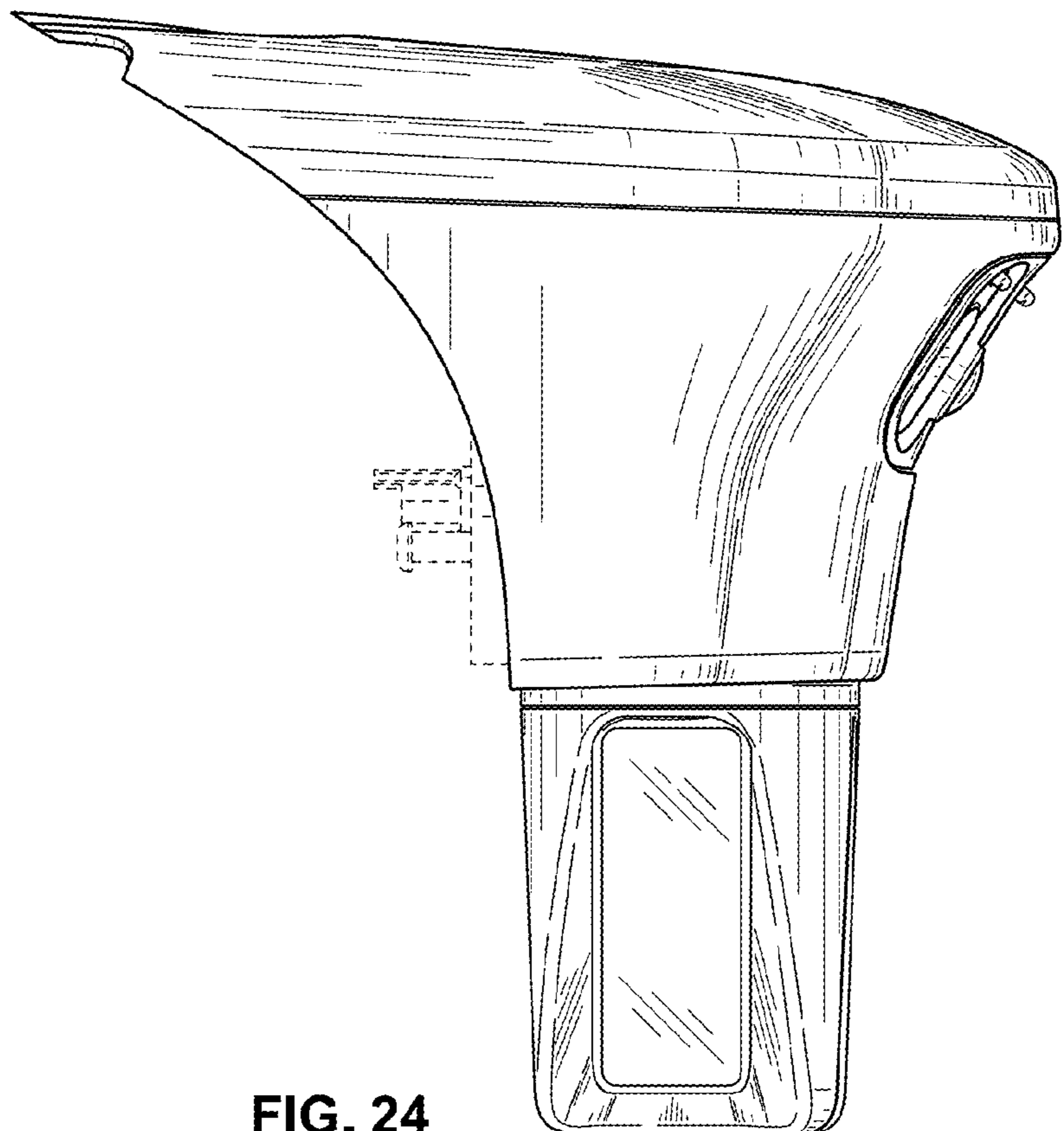

FIG. 24

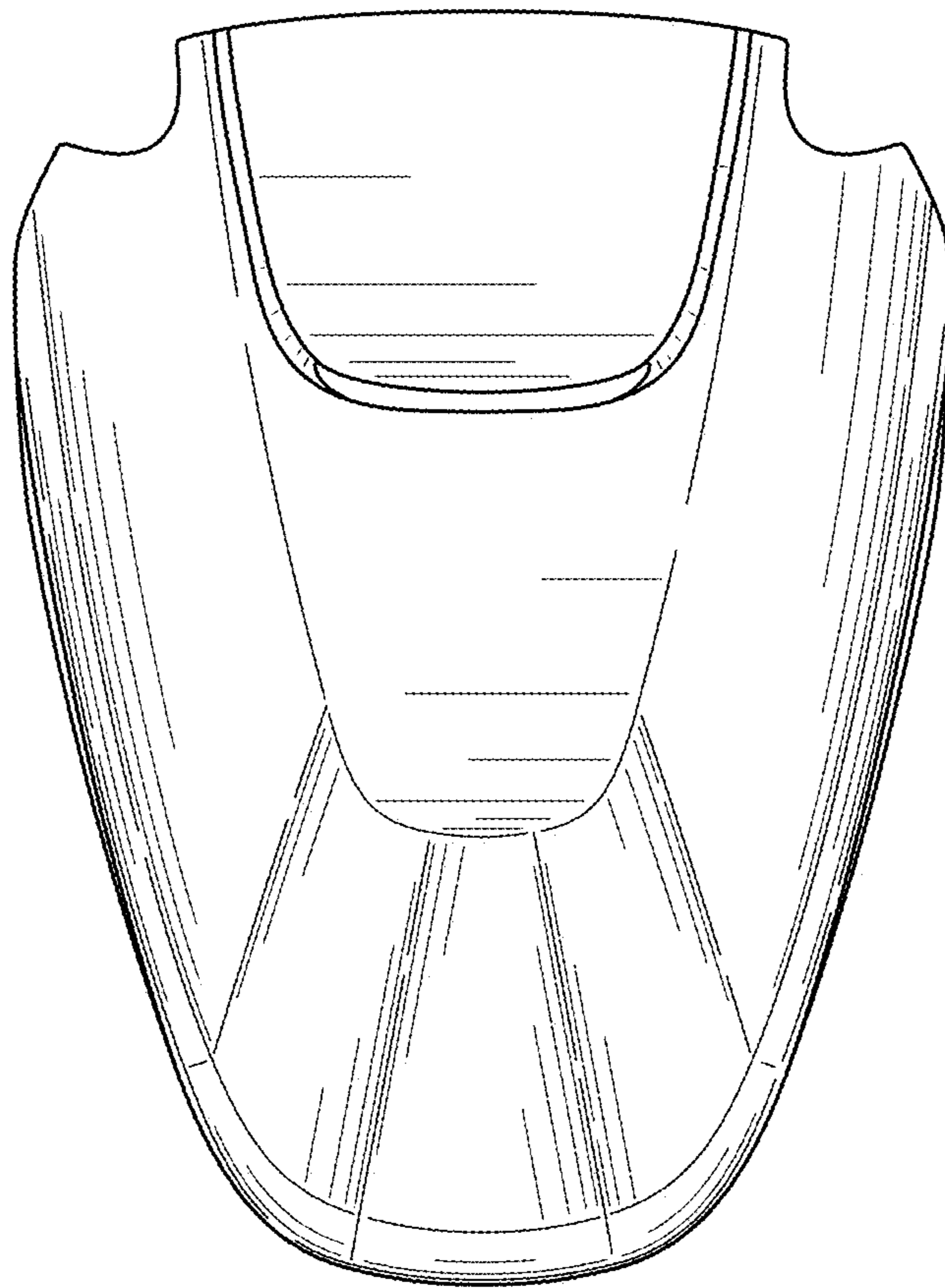

FIG. 25