



US00D953939S

(12) **United States Design Patent** (10) **Patent No.:** **US D953,939 S**
Kermani (45) **Date of Patent:** **** Jun. 7, 2022**

(54) **DRIFTING KART**

(56)

References Cited

(71) Applicant: **Ali Kermani**, Huntington Beach, CA (US)

U.S. PATENT DOCUMENTS

(72) Inventor: **Ali Kermani**, Huntington Beach, CA (US)

1,231,531 A	6/1917	Shilling
1,932,031 A	10/1933	Saverio
3,062,559 A	6/1959	Hewitt
D189,614 S	1/1961	Beale
D190,024 S	4/1961	Rouse
3,053,550 A	9/1962	Joachim et al.
3,099,326 A	7/1963	Weigel et al.
3,125,177 A	3/1964	Pallet
3,512,599 A	5/1970	Hott et al.
3,533,484 A	10/1970	Wood, Jr.
D222,283 S	10/1971	Reeves
3,700,058 A	10/1972	Kuwahara
3,799,283 A	3/1974	Freber
3,829,117 A	8/1974	Park
3,938,608 A	2/1976	Folco-Zambelli
3,960,392 A	6/1976	Read
D243,627 S	3/1977	Clower
D246,198 S	10/1977	Rose
4,065,144 A	12/1977	Winchell
D249,496 S	9/1978	Morgan
D251,264 S	3/1979	Cook et al.
D252,714 S	8/1979	Tidwell
4,281,844 A	8/1981	Jackman et al.
4,359,231 A	11/1982	Mulcahy
4,403,673 A	9/1983	Ball
D276,058 S	10/1984	Rogers
D280,916 S	10/1985	Castle
4,572,535 A	2/1986	Stewart
D290,451 S	6/1987	Engum
4,682,668 A	7/1987	Salmon et al.
4,750,578 A	6/1988	Brandenfels
4,826,190 A	5/1989	Hartmann
4,886,294 A	12/1989	Nahachewski
4,896,899 A	1/1990	Lawrence
4,898,508 A	2/1990	Hayata
4,915,075 A	4/1990	Brown
4,944,360 A	7/1990	Sturges
4,993,733 A	2/1991	Eilers
5,036,938 A	8/1991	Blount et al.
D320,420 S	10/1991	Dupont
D320,586 S	10/1991	Tellinghuisen
D332,765 S	1/1993	Tellinghuisen
D332,977 S	2/1993	Huffman et al.
5,257,671 A	11/1993	Watkins
5,265,690 A	11/1993	Amundsen et al.
5,340,139 A	8/1994	Davis
D355,879 S	2/1995	Winbald
D356,765 S	3/1995	DiMatteo
5,477,936 A	12/1995	Sugioka et al.

(**) Term: **15 Years**

(21) Appl. No.: **29/774,679**

(22) Filed: **Mar. 18, 2021**

Related U.S. Application Data

(63) Continuation of application No. 29/698,467, filed on Jul. 17, 2019, now Pat. No. Des. 913,878, which is a continuation of application No. 29/604,471, filed on May 17, 2017, now Pat. No. Des. 854,457, which is a continuation of application No. 29/571,286, filed on Jul. 15, 2016, now Pat. No. Des. 787,379, which is a continuation of application No. 29/488,366, filed on Apr. 17, 2014, now Pat. No. Des. 761,700, which is a continuation of application No. 13/745,648, filed on Jan. 18, 2013, now Pat. No. 8,875,831, which is a continuation of application No. 12/888,672, filed on Sep. 23, 2010, now Pat. No. 8,356,686, which is a continuation of application No. 12/505,955, filed on Jul. 20, 2009, now Pat. No. 7,823,675.

(51) **LOC (13) Cl.** **12-11**

(52) **U.S. Cl.**
USPC **D12/112; D21/426**

(58) **Field of Classification Search**
USPC D12/1, 87, 107, 110–114, 129, 130, 133;
D21/412, 414, 419, 423–428, 431–435
CPC B60K 7/0007; B62D 23/00; B62D 29/004;
B62D 61/08; B62D 63/02; B62D 9/00;
B60L 11/1805; B60L 11/1818; B60L
11/1879; B60L 11/1877

See application file for complete search history.

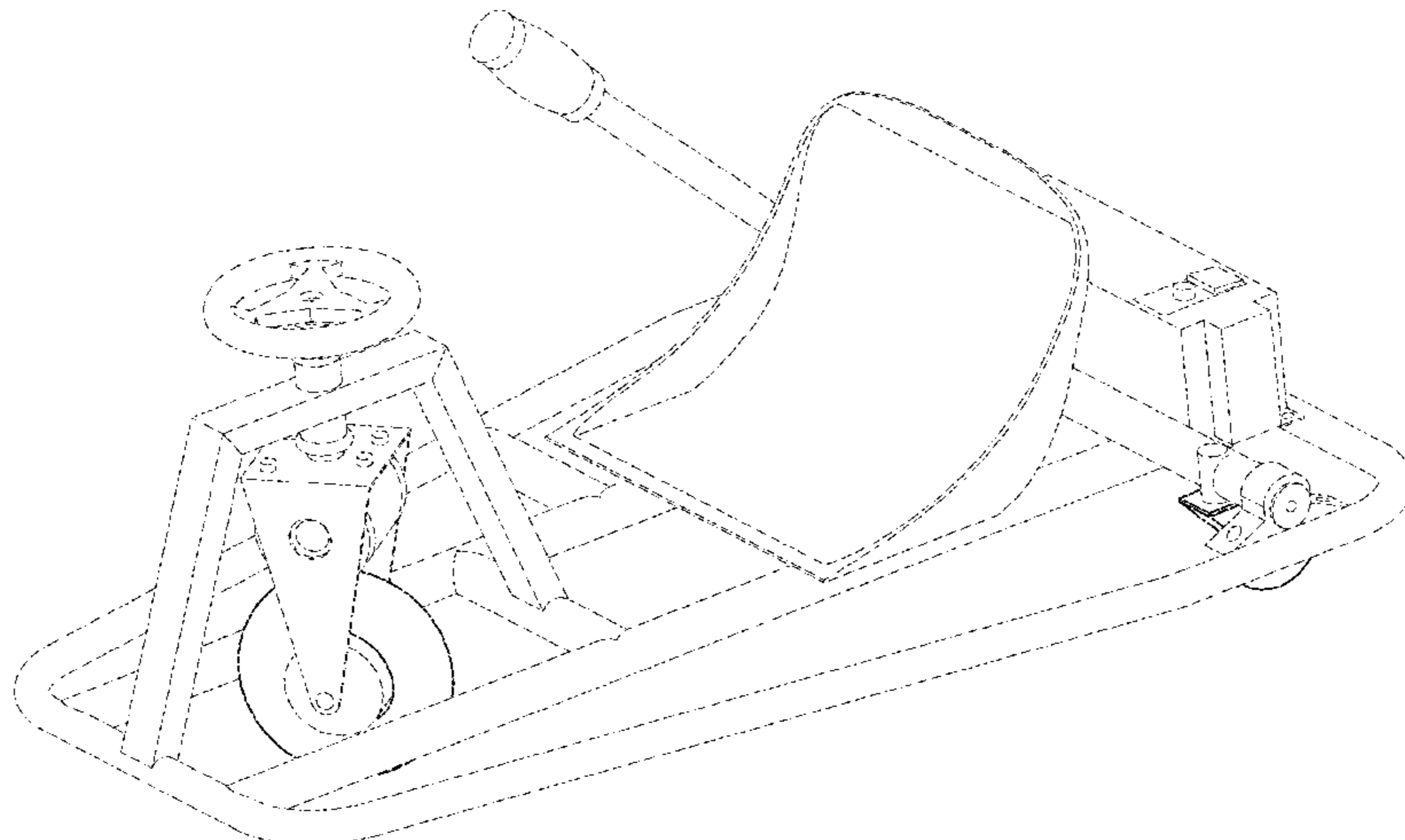

US D953,939 S

D366,021 S	1/1996	Tharp	D692,506 S	10/2013	Jiang	
5,479,998 A	1/1996	Ishikawa	8,627,910 B1	1/2014	Carque	
5,494,126 A	2/1996	Meeker	D705,128 S	5/2014	Patterson et al.	
D369,130 S	4/1996	Cummings	8,757,644 B2	6/2014	Satou	
D378,226 S	2/1997	Sundqvist	8,801,005 B1	8/2014	Flickner et al.	
5,628,379 A	5/1997	Watkins	8,820,460 B2	9/2014	Chen	
D390,281 S	2/1998	O'Rourke	8,840,131 B1	9/2014	Calley	
D394,164 S	5/1998	Safrit	8,875,831 B2	11/2014	Kermani	
5,816,592 A	10/1998	Horton, II et al.	8,931,583 B2	1/2015	Tuckowski	
5,826,670 A	10/1998	Nan	9,102,375 B2	8/2015	Kermani	
D404,928 S	2/1999	Safrit	D739,318 S	9/2015	Rancan et al.	
D408,869 S	4/1999	Patmont	9,139,248 B2	9/2015	Xiao	
D409,538 S	5/1999	Isetani et al.	D761,700 S *	7/2016	Kermani	D12/112
5,904,218 A	5/1999	Watkins	D766,780 S	9/2016	Fusco	
D410,880 S	6/1999	Conterno	D771,196 S *	11/2016	Chen	D21/424
D412,138 S	7/1999	Triarsi et al.	9,499,220 B2	11/2016	Kermani	
5,931,499 A	8/1999	Sutherland	D773,359 S	12/2016	Okuyama et al.	
D419,507 S	1/2000	Triarsi et al.	D774,602 S	12/2016	Desberg	
6,022,049 A	2/2000	Wiggins, Jr.	D774,981 S *	12/2016	Chen	D12/112
6,026,923 A	2/2000	Uphaus	D775,282 S	12/2016	Williams et al.	
6,047,786 A	4/2000	Stevenson et al.	D776,016 S	1/2017	Androski et al.	
D424,996 S	5/2000	McShay, Jr.	D776,204 S	1/2017	Van Den Berg	
D433,828 S	11/2000	Safrit	9,557,740 B2	1/2017	Crawley	
D434,086 S	11/2000	Ford	D778,369 S	2/2017	Douma et al.	
D439,871 S	4/2001	Goebert et al.	D783,726 S	4/2017	Williams et al.	
D440,607 S	4/2001	Mahlow	D787,379 S *	5/2017	Kermani	D12/112
D445,740 S	7/2001	Hartog	D787,610 S *	5/2017	Desberg	D21/425
6,267,190 B1	7/2001	Micheletti	D789,262 S	6/2017	Chen	
6,276,480 B1	8/2001	Aregger	D792,811 S	7/2017	Kermani et al.	
6,349,786 B1	2/2002	Gift	D793,480 S *	8/2017	Chen	D21/424
D460,723 S	7/2002	Smit	D793,481 S *	8/2017	Kermani	D21/426
D465,814 S	11/2002	Koveleski	D793,912 S *	8/2017	Kermani	D12/112
D466,560 S	12/2002	Stolpmann	D801,242 S	10/2017	Kim	
D469,819 S	2/2003	Nicolle et al.	D807,438 S	1/2018	Desberg	
D471,936 S	3/2003	Tilbor et al.	D809,982 S	2/2018	Hosozawa	
6,530,598 B1	3/2003	Kirby	D813,314 S	3/2018	Montagne	
D482,882 S	12/2003	Murphy	D816,001 S	4/2018	Kim	
D483,191 S	12/2003	Murphy	D820,178 S	6/2018	Kim	
D483,420 S	12/2003	Delong et al.	D820,733 S *	6/2018	Chen	D12/112
D488,194 S	4/2004	Fox et al.	D827,522 S	9/2018	Villamizar et al.	
6,729,421 B1	5/2004	Gluck	D830,469 S	10/2018	Kermani et al.	
6,749,039 B1	6/2004	Uphaus	D830,470 S	10/2018	Chen	
D493,391 S	7/2004	Gunter	10,245,194 B2	4/2019	Kermani	
6,766,871 B2	7/2004	Sawyer	10,266,197 B2 *	4/2019	Desberg	B62B 7/00
D498,709 S	11/2004	Sramek	D848,166 S	5/2019	Braun	
D500,707 S	1/2005	Lu	D850,328 S	6/2019	Allais	
D503,658 S	4/2005	Lu	D852,892 S *	7/2019	Chen	D21/426
D512,467 S *	12/2005	Hadley	D852,893 S *	7/2019	Kermani	D21/426
D513,483 S	1/2006	Buhrman	D854,457 S	7/2019	Kermani	
7,117,967 B2	10/2006	Kidd	D854,458 S *	7/2019	Kermani	D12/112
7,198,322 B2	4/2007	Savo	D855,339 S	8/2019	Ochs	
D557,911 S	12/2007	Herold, III et al.	10,434,860 B2	10/2019	Chen et al.	
D562,914 S	2/2008	Oveson et al.	D872,657 S	1/2020	Li	
D570,572 S	6/2008	Whiteside et al.	10,543,776 B2	1/2020	Matsushima	
D574,297 S	8/2008	Carl	D874,986 S *	2/2020	Chen	D12/112
D575,675 S	8/2008	Williams et al.	D890,854 S	7/2020	Kermani et al.	
D582,489 S	12/2008	Bandanjo	D890,855 S	7/2020	Chen	
D582,992 S *	12/2008	Alais	10,822,014 B2	11/2020	Boittiaux et al.	
D587,176 S	2/2009	Yang et al.	10,843,720 B2	11/2020	Kwon et al.	
7,552,934 B2	6/2009	Lee et al.	D913,165 S	3/2021	Kermani	
D601,640 S	10/2009	McIlvain et al.	D913,878 S	3/2021	Kermani	
D608,250 S	1/2010	Van De	2002/0011374 A1	1/2002	Brister	
D611,106 S	3/2010	Van Beek	2002/0175027 A1	11/2002	Usherovich	
7,712,558 B2	5/2010	Helson et al.	2003/0102657 A1	6/2003	Kuo	
D619,519 S	7/2010	Granata	2004/0035627 A1	2/2004	Richey et al.	
D619,943 S	7/2010	Granata	2004/0040769 A1	3/2004	Richey et al.	
7,779,850 B2	8/2010	Caldwell	2004/0199311 A1 *	10/2004	Aguilar	G09B 9/042 701/36
7,823,675 B2	11/2010	Kermani				
D637,116 S	5/2011	Kettler	2005/0103554 A1	5/2005	Meglioli	
D637,660 S	5/2011	Markowitz	2005/0173180 A1	8/2005	Hypes et al.	
D644,580 S	9/2011	Markowitz et al.	2007/0045022 A1	3/2007	Greig et al.	
D646,086 S	10/2011	Hickman et al.	2007/0151777 A1	7/2007	Peng	
8,091,658 B2	1/2012	Peng	2008/0122209 A1	5/2008	Jayasuriya	
8,356,686 B2	1/2013	Kermani	2008/0196951 A1	8/2008	Gal et al.	
8,365,850 B2	2/2013	Gal et al.	2009/0007721 A1	1/2009	Cortina et al.	
D682,739 S	5/2013	Patterson et al.	2009/0065272 A1	3/2009	Martin et al.	
D682,746 S	5/2013	Doherty et al.	2010/0032223 A1 *	2/2010	Kermani	B62K 5/025 180/216
D690,147 S	9/2013	Meyer				
D692,505 S	10/2013	Jiang	2012/0133111 A1	5/2012	Schmutzer et al.	

2015/0328994 A1* 11/2015 Chen B62D 61/08
180/65.31
2016/0214557 A1 7/2016 Villa
2017/0156953 A1 6/2017 Kermani
2018/0043950 A1* 2/2018 Kermani B62D 29/004
2020/0022856 A1 1/2020 Kermani
2020/0062100 A1 2/2020 Chen et al.

FOREIGN PATENT DOCUMENTS

CN	2198169	Y	5/1995
CN	1569548	A	1/2005
CN	2936826		8/2007
CN	200977859		11/2007
CN	201009762	Y	1/2008
CN	203186508	U	9/2013
CN	203427959	U	2/2014
CN	203864416	U	10/2014
CN	204527453	U	8/2015
CN	105083006	A	11/2015
CN	205087107	U	3/2016
CN	206012763	U	3/2017
EP	0529188	A1	3/1993
FR	859864	A	12/1940
JP	07-285345	A	10/1995
JP	2000-127982	A	5/2000
JP	2007-082817	A	4/2007
JP	2010-047206	A	3/2010
WO	WO 2018/032730		2/2018
WO	WO 2018/035060	A1	2/2018

OTHER PUBLICATIONS

Aamoth, Doug, "Razor Builds the Ultimate Drifting Go-Kart: Why Must I Always Be Over the Weight Limit for Everything Good in This World?," Jul. 11, 2013, retrieved on Aug. 6, 2016, <http://techland.time.com/2013/07/11/razor-builds-the-ultimate-drifting-go-kart-why-must-i-always-be-over-the-weight-limit-for-everything-good-in-this-world/>, in 2 pages.

Otl Elektokart, "Storm Series—Competition" Datasheet, Jun. 14, 2014, retrieved on Aug. 6, 2016, <https://www.kart1.com/pdf/competition.pdf>, in 3 pages.

Razor USA: "Crazy Cart", Jul. 21, 2016 (Jul. 21, 2016), Retrieved from the Internet: URL: https://www.razor.com/wp-content/uploads/2018/02/CrazyCartshift_MAN_US_160721-1.pdf [retrieved on Mar. 3, 2020].

Recreation Ltd. "Razor Crazy Cart Shift Ride Video", Youtube, Aug. 15, 2016 (Aug. 15, 2016), Retrieved from the Internet: URL: <https://youtube.com/watch?v=KjrfsfSiMZ4> [retrieved on Apr. 10, 2020].

* cited by examiner

Primary Examiner — Darlington Ly
(74) *Attorney, Agent, or Firm* — Knobbe, Martens, Olson & Bear, LLP

(57) **CLAIM**

The ornamental design for a drifting kart, as shown and described.

DESCRIPTION

FIG. 1 is a top, front, and left side perspective view of a drifting kart showing my new design;

FIG. 2 is a right side elevation view thereof;

FIG. 3 is a front elevation view thereof;

FIG. 4 is a rear elevation view thereof;

FIG. 5 is a top plan view thereof; and,

FIG. 6 is a bottom plan view thereof.

The broken lines in the drawings illustrate portions of the drifting kart that form no part of the claimed design.

1 Claim, 6 Drawing Sheets

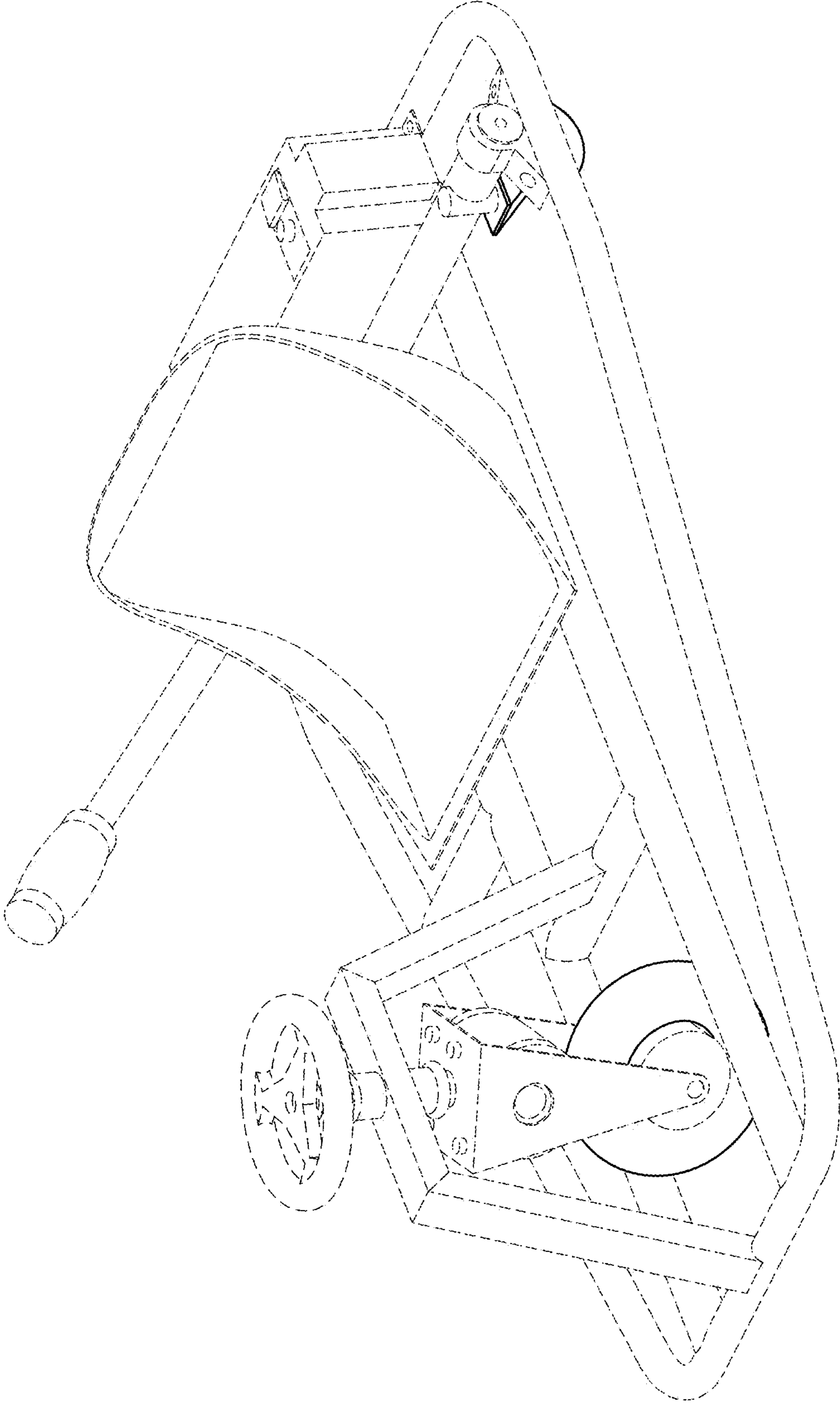

FIG. 1

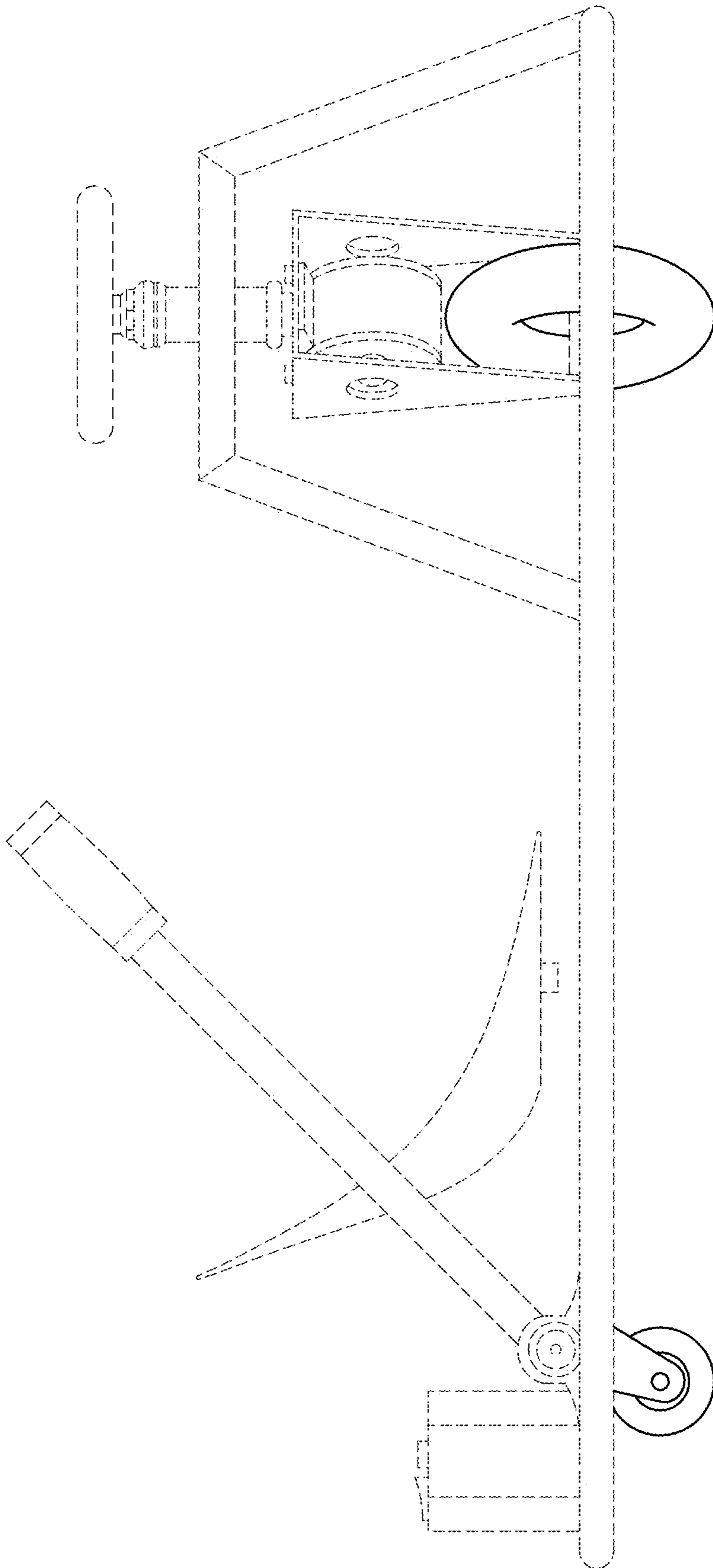

FIG. 2

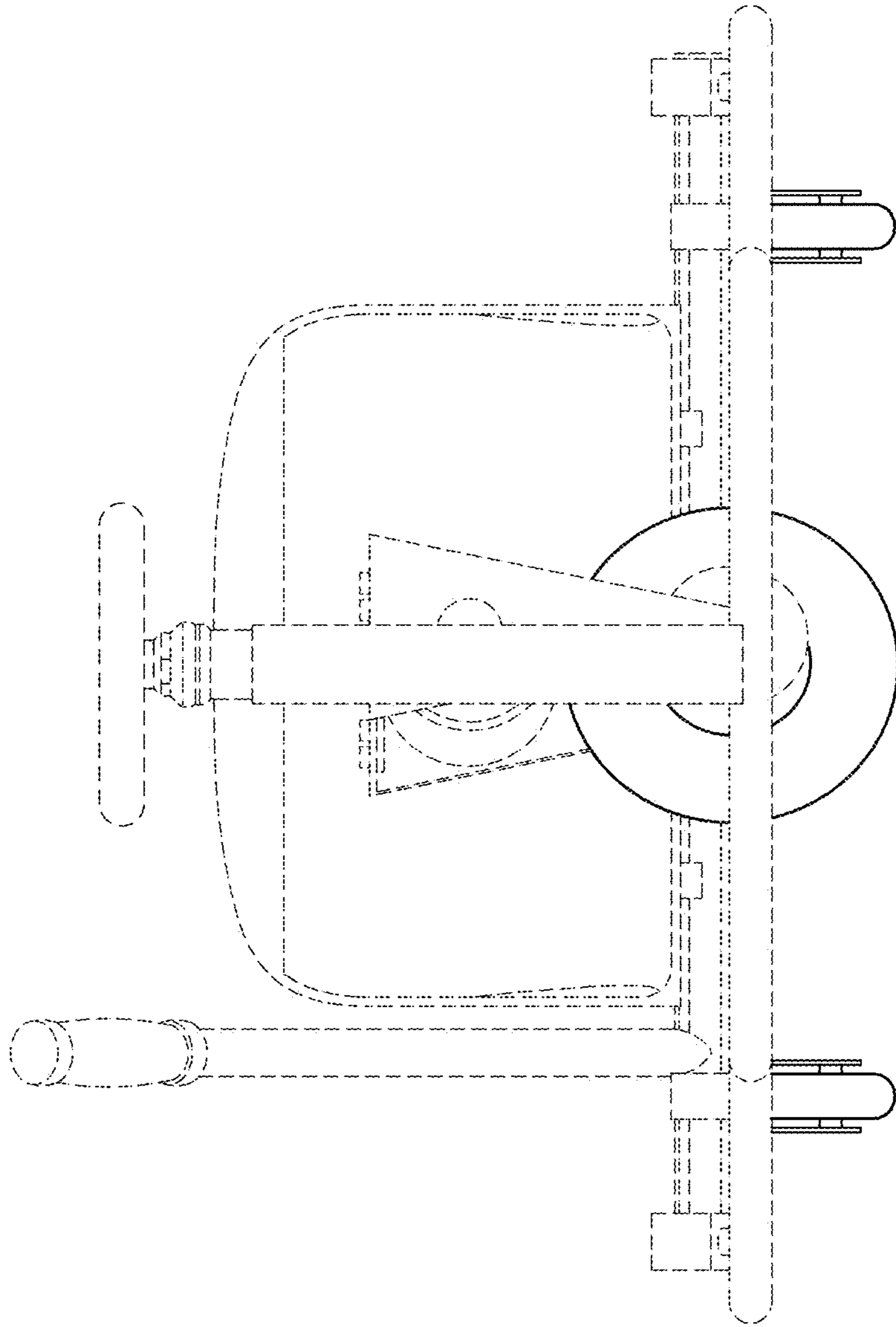

FIG. 3

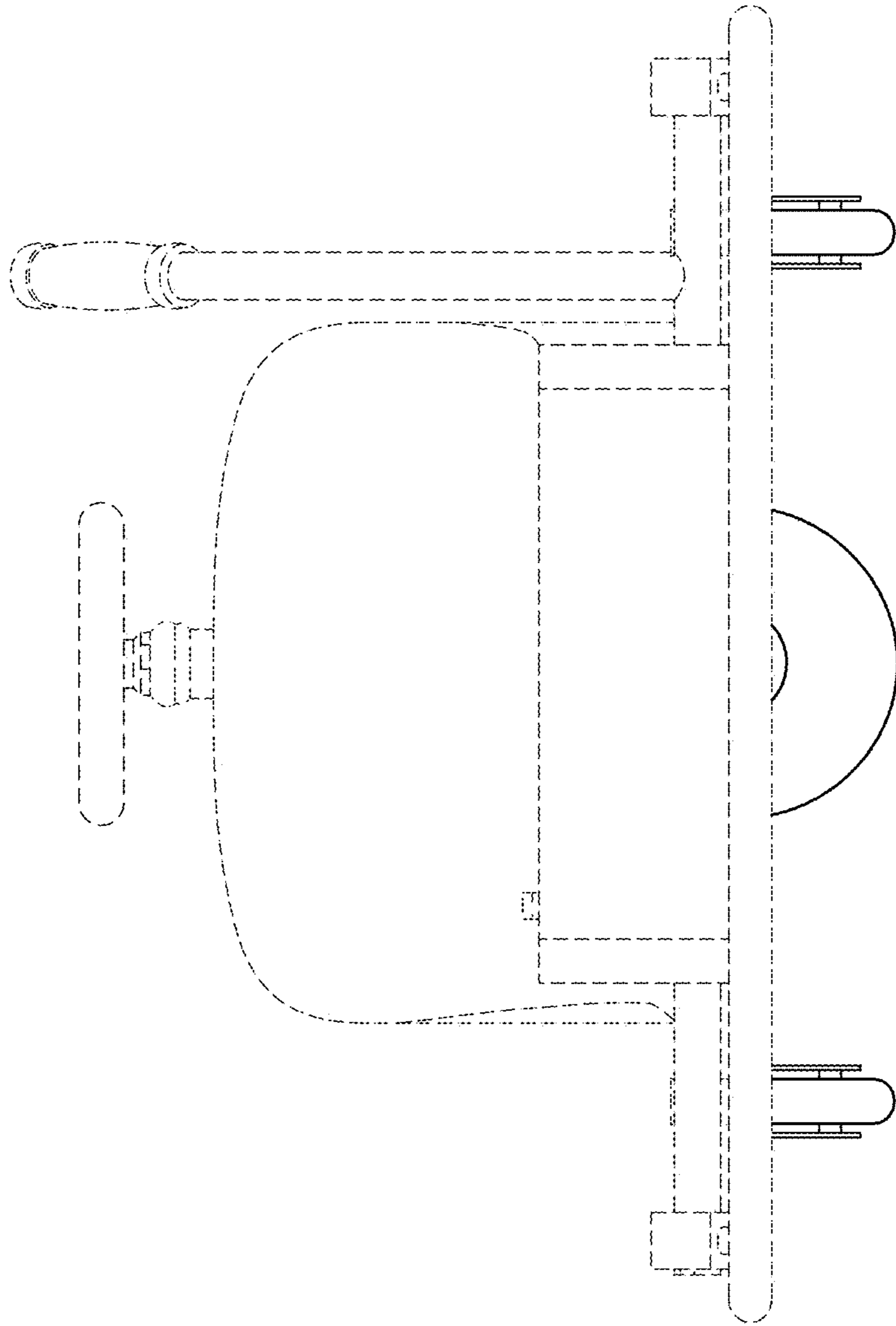

FIG. 4

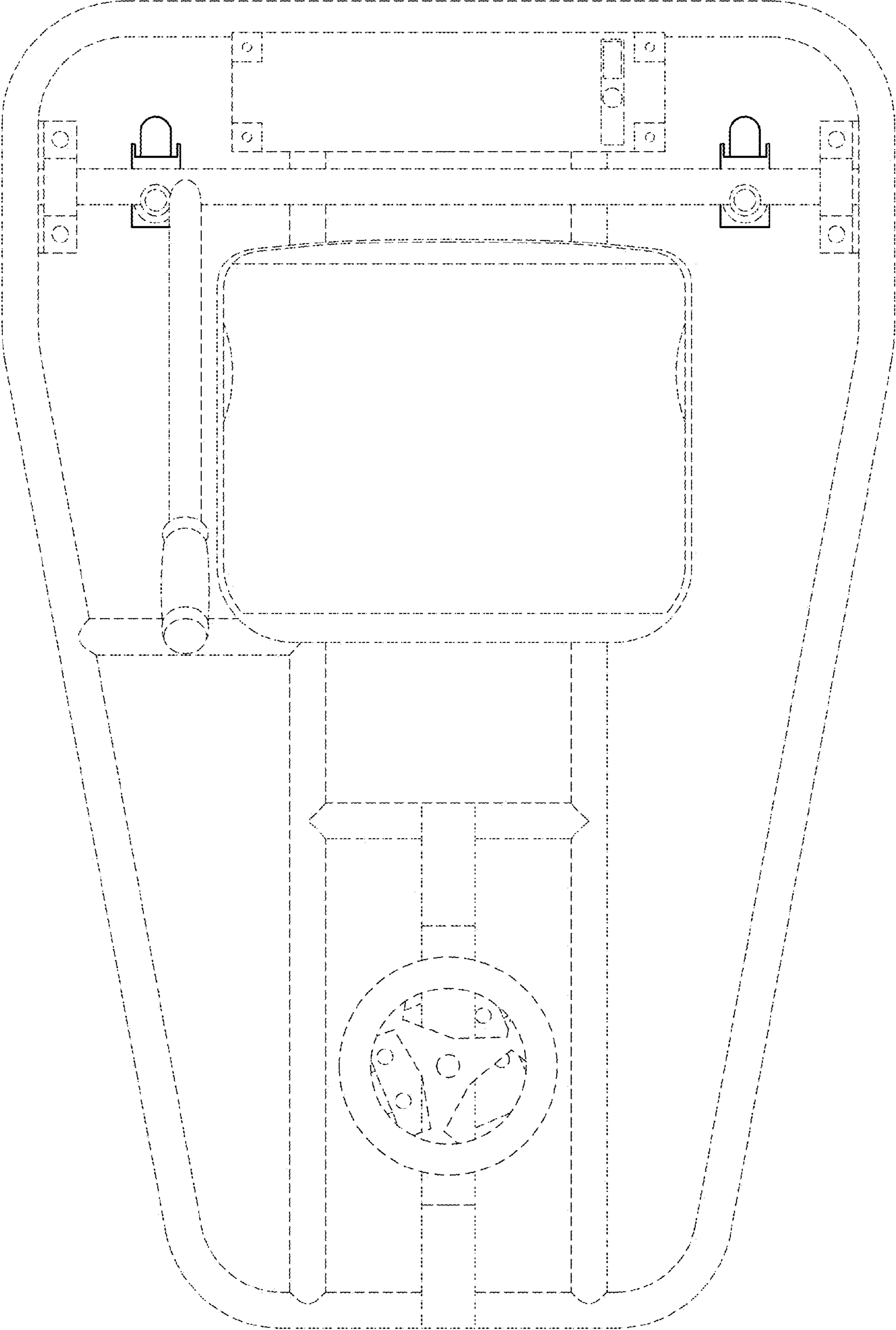

FIG. 5

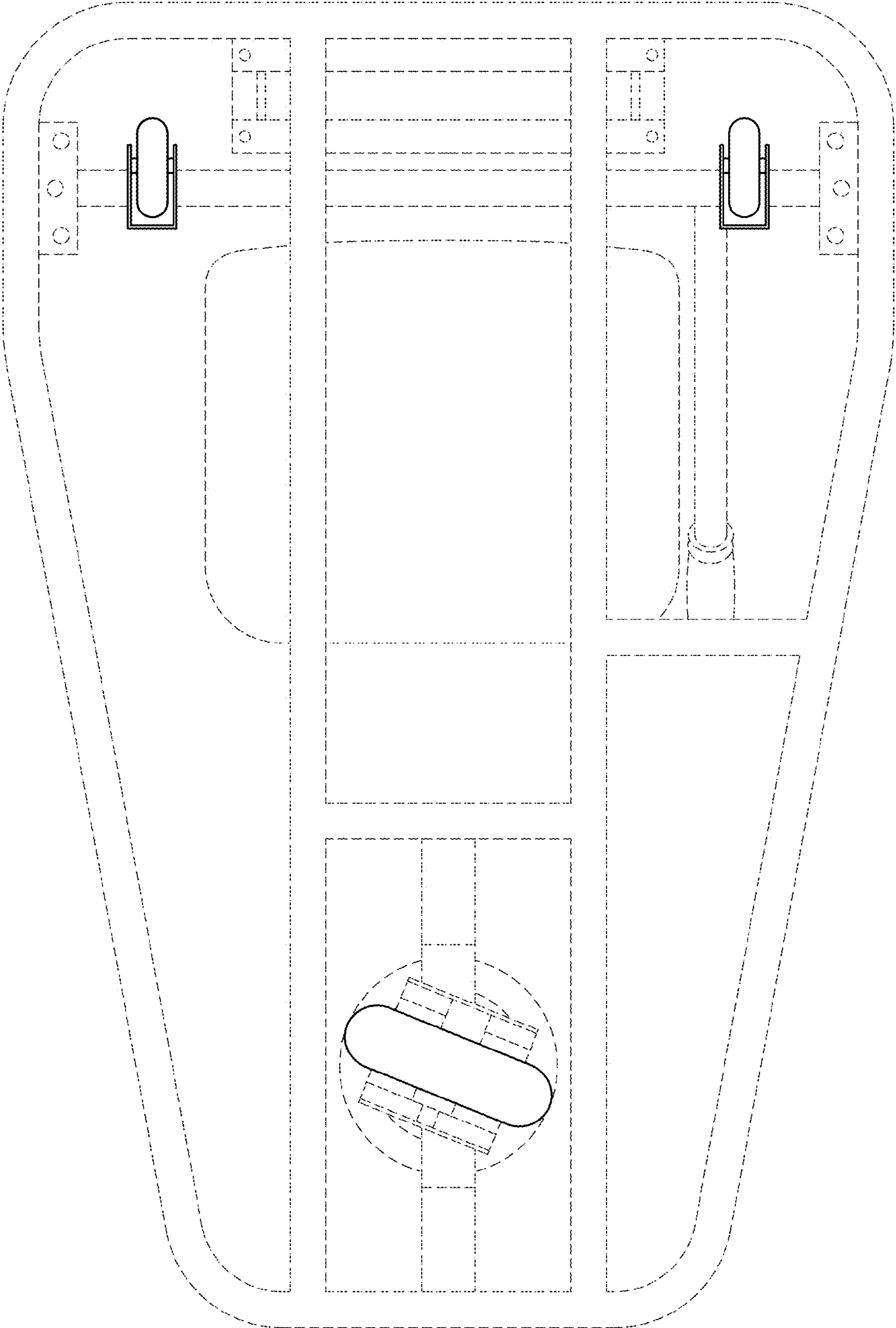

FIG. 6