



US00D953613S

(12) **United States Design Patent**
Powell et al.

(10) **Patent No.:** **US D953,613 S**
(45) **Date of Patent:** **** May 31, 2022**

(54) **AEROSOL GENERATOR**

(71) Applicant: **Nicoventures Trading Limited**,
London (GB)

(72) Inventors: **David Hillary Powell**, London (GB);
Matthew Peter Tidnam, London (GB);
Alex Pearce, London (GB); **Caroline**
Jeanne Victoire Jacob, London (GB)

(73) Assignee: **Nicoventures Trading Limited**,
London (GB)

(**) Term: **15 Years**

(21) Appl. No.: **29/705,487**

(22) Filed: **Sep. 12, 2019**

(30) **Foreign Application Priority Data**

Mar. 13, 2019 (EM) 006306700

(51) **LOC (13) Cl.** **27-02**

(52) **U.S. Cl.**
USPC **D27/162**

(58) **Field of Classification Search**

USPC D27/100, 101, 162, 163, 164, 165, 166,
D27/167, 168, 169, 170, 171, 172, 173,
D27/174, 175, 176, 177, 178, 179, 180,
D27/181, 182, 183, 184, 185, 186, 187,
D27/188, 189, 190, 191, 192, 193;
D24/110, 110.4, 110.5, 110.6, 113;
D28/91.1; D23/360, 362

CPC A24F 47/008; A24F 40/10; A24F 40/40;
A24F 40/46; A24F 40/42; A24F 40/44;
A24F 40/50; A24F 40/90; A24F 47/00;
A24F 40/60; A24F 40/70; A24F 40/48;
A24F 40/485; A24F 40/53; A24F 40/51;
A24F 47/002; A24F 40/57; A24F 40/65;
A24F 40/20; A24F 7/00; A24F 40/30;
A24F 47/004; A24F 40/05; A24F 15/00;
A24F 1/32; A24F 40/00; A24F 40/49;
A24F 40/85; A24F 42/60; A24F 7/02;
A24F 7/04; A24F 9/16; A24F 13/06;

A24F 13/04; A24F 40/465; A24F 40/95;
A24F 13/00; A24F 13/14; A24F 15/01;
A24F 15/015; A24F 15/12; A24F 15/14;
A24F 15/18; A24F 1/02; A24F 2700/03;
A24F 42/00; A24F 42/20; A24F 1/00;
A61M 11/042; A61M 15/06; A61M
2205/8206; A61M 2205/3653; A61M
11/005; A61M 2016/0024; A61M
2016/0027; A61M 2205/587; A61M
11/044; A61M 15/0085; A61M 16/0003;
A61M 2205/0211; A61M 2205/3368;
A61M 2205/8256; A61M 11/003; A61M
15/002; A61M 2016/0021; A61M 11/001;
A61M 11/04; A61M 15/0021; A61M
15/0025; A61M 15/008; A61M
2016/0018; A61M 2016/0033; A61M
2016/0039; A61M 2021/0016; A61M
21/00; A61M 2205/3331; A61M
2205/3334; A61M 2205/3379; A61M
2205/52; A61M 2205/58; A61M
2205/583; A61M 2205/6018; A61M
2205/6054; A61M 2205/75; A61M
2205/8268; A61M 2206/11; A61M
2206/20; A61M 2209/02; A61M
2209/045; A61M 11/041; A61M 15/0001;
A61M 15/0015; A61M 15/0028; A61M
15/0091; A61M 15/0095; A61M 16/0808;
A61M 2205/0238; A61M 2205/0272;
A61M 2205/123; A61M 2205/7536;
A61M 2205/18; A61M 2205/3317; A61M
2205/3386; A61M 2205/50

See application file for complete search history.

(56)

References Cited

U.S. PATENT DOCUMENTS

174,884 A 3/1876 Wolff
239,198 A 3/1881 Simonds
239,776 A 4/1881 Henley
D22,270 S 3/1893 Kinney
D27,458 S 8/1897 Cameron
1,927,956 A 9/1933 Segal
2,371,557 A 3/1945 Sullivan
D164,391 S 8/1951 Wagner
D174,884 S 5/1955 Nelson et al.

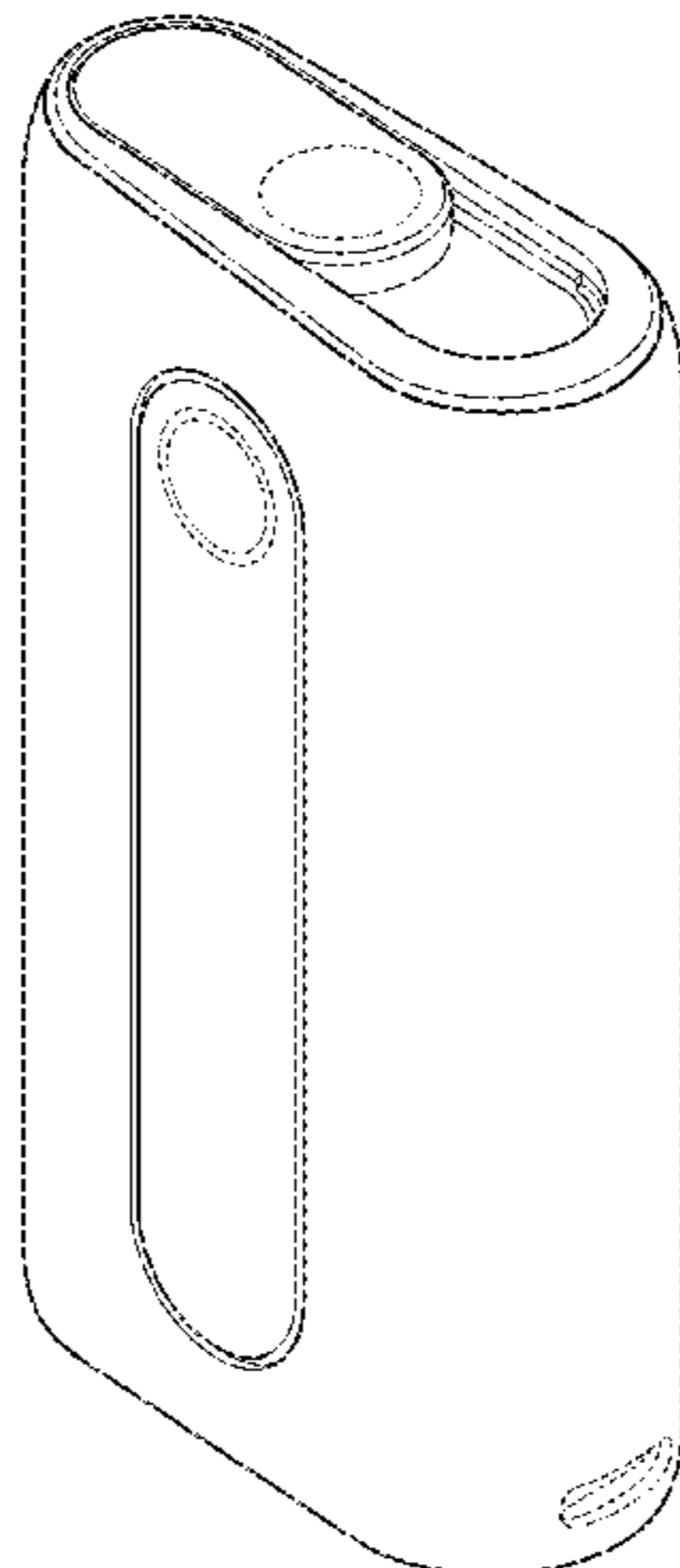

US D953,613 S

D239,198 S	3/1976	Nau	D833,384 S	11/2018	Takayanagi
D239,631 S	4/1976	Gilles Lauri	10,136,679 B1	11/2018	Shotey et al.
D239,776 S	5/1976	Kenjiro	D835,857 S	12/2018	Benacquisto et al.
4,214,658 A	7/1980	Crow	D839,823 S	2/2019	Lemelson et al.
D284,506 S	7/1986	Gutknecht	10,194,697 B2	2/2019	Fernando et al.
D301,837 S	6/1989	Peterson et al.	D842,237 S *	3/2019	Qiu D13/103
D303,766 S	10/1989	Delbanco	D842,243 S	3/2019	Qiu
5,144,962 A	9/1992	Counts et al.	D843,052 S *	3/2019	Powell D27/163
D360,281 S	7/1995	Kim	D844,030 S	3/2019	You
5,564,442 A	10/1996	MacDonald et al.	D848,603 S	5/2019	Fujino et al.
5,665,262 A	9/1997	Hajaligol et al.	D853,022 S *	7/2019	Srouf D27/183
5,878,752 A	3/1999	Adams et al.	D854,236 S	7/2019	Qiu
D422,113 S	3/2000	Higgins et al.	D861,549 S	10/2019	Lai
D424,236 S	5/2000	Reed	D869,086 S *	12/2019	Pan D27/162
D437,112 S	2/2001	Toffoli	D870,367 S	12/2019	Chung et al.
D446,849 S	8/2001	Weinburg	D872,355 S	1/2020	Powell et al.
D506,001 S	6/2005	Christianson	D876,214 S	2/2020	Yu
D512,493 S	12/2005	Haranaka	D881,458 S	4/2020	Ouyang
D538,222 S	3/2007	Curello et al.	D883,197 S	5/2020	Doucet
D558,060 S	12/2007	Šir	D883,563 S	5/2020	Pan
D558,330 S	12/2007	Chang	D884,266 S	5/2020	Wang
D576,718 S	9/2008	Nomi et al.	D884,961 S *	5/2020	He D27/101
D634,417 S	3/2011	Abbondanzio et al.	D885,332 S	5/2020	Han
D634,832 S	3/2011	Abbondanzio et al.	D885,337 S	5/2020	Xu
D643,732 S	8/2011	Cummings et al.	D885,651 S *	5/2020	Miyamoto D27/101
7,988,660 B2	8/2011	Byland et al.	D888,326 S	6/2020	Qiu
D645,757 S	9/2011	Milhem et al.	D888,329 S	6/2020	Qiu
D648,340 S	11/2011	Okura	D889,740 S	7/2020	Beer et al.
D650,472 S	12/2011	Petersen	D891,692 S	7/2020	Barbaric et al.
D654,160 S	2/2012	Yomtov	D892,124 S	8/2020	Shim
D657,857 S	4/2012	Choi	D893,009 S	8/2020	Choi
D663,891 S	7/2012	Cohen Harel	D894,476 S *	8/2020	Miyamoto D27/101
D664,709 S	7/2012	Almsberger et al.	D896,519 S *	9/2020	Cooper D3/298
D665,734 S	8/2012	Fitch et al.	D897,596 S	9/2020	Huang et al.
D674,479 S	1/2013	Merchant et al.	D898,280 S *	10/2020	Li D27/162
D677,623 S	3/2013	Fitch et al.	D898,990 S *	10/2020	Liu D27/162
D677,774 S	3/2013	Postma	D898,991 S	10/2020	Pan
8,528,780 B2	9/2013	Houghton et al.	10,791,765 B2	10/2020	Li et al.
D695,396 S	12/2013	Tani et al.	D901,072 S	11/2020	Goradesky
D696,815 S	12/2013	Abroff	D904,401 S	12/2020	Wu
D700,397 S	2/2014	Manca et al.	D904,678 S	12/2020	Wang et al.
D704,319 S	5/2014	Cai	D905,901 S	12/2020	Kim et al.
D708,129 S	7/2014	Houghton et al.	D908,344 S	1/2021	Jones
D708,727 S	7/2014	Postma	D908,834 S	1/2021	Cho et al.
D714,647 S	10/2014	Kersten	D908,952 S	1/2021	Guo
D715,760 S	10/2014	Kim et al.	D910,231 S	2/2021	Liu et al.
D716,267 S	10/2014	Kim et al.	D910,911 S	2/2021	Kim et al.
D728,855 S	5/2015	Liu	D911,181 S	2/2021	Lee
D729,440 S	5/2015	Liu	D924,472 S *	7/2021	Powell D27/162
D729,445 S *	5/2015	Leidel D27/186	D924,473 S *	7/2021	Powell D27/162
D732,023 S	6/2015	Asao	D928,393 S *	8/2021	Powell D27/162
D734,395 S	7/2015	Lir et al.	2004/0025865 A1	2/2004	Nichols et al.
D736,455 S *	8/2015	Liu D27/189	2005/0199610 A1	9/2005	Ptasienski et al.
D740,673 S	10/2015	Corradini et al.	2007/0074734 A1	4/2007	Braunshteyn et al.
D743,099 S	11/2015	Oglesby	2007/0283972 A1	12/2007	Monsees et al.
D743,889 S	11/2015	Lyles et al.	2009/0114737 A1	5/2009	Yu et al.
D745,404 S	12/2015	Julier et al.	2010/0236561 A1	9/2010	Barnes et al.
D746,771 S	1/2016	Perez	2011/0108025 A1	5/2011	Fink et al.
D758,656 S	6/2016	Freshwater et al.	2011/0240047 A1	10/2011	Adamic
D759,296 S	6/2016	Abroff et al.	2011/0290244 A1	12/2011	Schennum
D760,414 S	6/2016	Brown et al.	2013/0042865 A1	2/2013	Monsees et al.
D768,834 S	10/2016	Schuller et al.	2014/0060554 A1	3/2014	Collett et al.
D771,867 S	11/2016	Leidel et al.	2014/0069444 A1	3/2014	Cyphert et al.
D773,114 S	11/2016	Leidel et al.	2014/0196718 A1	7/2014	Li et al.
9,499,332 B2	11/2016	Fernando et al.	2014/0366898 A1	12/2014	Monsees et al.
D775,762 S	1/2017	Chen	2015/0053217 A1	2/2015	Steingraber et al.
D778,831 S	2/2017	Chen	2015/0059787 A1	3/2015	Qiu
D787,657 S	5/2017	Farone et al.	2015/0101606 A1	4/2015	White
D787,728 S	5/2017	Wing et al.	2015/0101944 A1	4/2015	Li et al.
D788,364 S	5/2017	Chen	2015/0181937 A1	7/2015	Bubief et al.
D807,575 S	1/2018	Luo	2015/0189919 A1	7/2015	Liu
D818,637 S	5/2018	Ringel	2015/0245658 A1	9/2015	Worm et al.
D819,023 S	5/2018	Shim	2016/0007652 A1	1/2016	Taluskie et al.
D821,640 S	6/2018	Qiu	2016/0081395 A1	3/2016	Thorens et al.
D828,295 S	9/2018	Li	2017/0231276 A1	8/2017	Mironov et al.
D828,622 S	9/2018	Chen et al.	2017/0232211 A1	8/2017	Gallem et al.
D828,912 S	9/2018	Powell et al.	2018/0168224 A1	6/2018	Naughton et al.
D828,950 S	9/2018	Gu	2018/0271151 A1	9/2018	Litten
D828,953 S	9/2018	Chen	2019/0029326 A1	1/2019	Qiu

2019/0046745	A1	2/2019	Nettenstrom
2019/0150508	A1*	5/2019	Thorsen A24F 47/008
2019/0166918	A1	6/2019	Thorsen et al.
2019/0200678	A1	7/2019	Thorsen et al.
2019/0208815	A1	7/2019	Thorsen
2019/0208816	A1*	7/2019	Thorsen H05B 3/06
2019/0208817	A1	7/2019	Qiu et al.
2019/0246693	A1	8/2019	Nettenstrom
2019/0387799	A1*	12/2019	Reevell H05B 3/06
2020/0187555	A1	6/2020	Lee
2020/0221782	A1	7/2020	Lim
2020/0245681	A1	8/2020	An
2020/0253280	A1	8/2020	Thorsen
2020/0345075	A1*	11/2020	Hepworth A24F 40/57
2020/0345960	A1*	11/2020	Begin A61M 11/042
2020/0359706	A1*	11/2020	Liu A24F 40/40
2021/0000169	A1*	1/2021	Hepworth A24D 1/22
2021/0007401	A1*	1/2021	Moloney A24F 40/51
2021/0015160	A1	1/2021	Moloney et al.
2021/0015161	A1	1/2021	Moloney et al.
2021/0015162	A1	1/2021	Moloney et al.

FOREIGN PATENT DOCUMENTS

CN	1126425	A	7/1996
CN	1190335	A	8/1998
CN	133657	A	1/2002
CN	1333657	A	1/2002
CN	304659647		6/2018
CN	304659654		6/2018
CN	304691359		6/2018
CN	304696494		6/2018
CN	304724787		7/2018
CN	304840668		10/2018
CN	201830112791	*	10/2018
CN	201830127884	*	12/2018
CN	201830464639.4	*	3/2019
CN	201830513209.7	*	5/2019
CN	201930202043.1	*	12/2019
DE	19854005	A1	5/2000
DE	19854009	A1	5/2000
EM	002611426-0001		3/2015
EM	002727099-0001	*	9/2017
EM	002727099-0007		9/2017
EM	0029810430001		5/2018
EP	2316286		5/2011
EP	2340729	A1	7/2011
EP	2797448	A2	11/2014
GB	191000639	A	12/1910
JP	590161	U	12/1993
JP	2003527127	A	9/2001
JP	2001521123	A	11/2001
JP	2009509521		3/2009
JP	2013509160		3/2013
JP	2014524313		9/2014
JP	2014525251	A	9/2014
JP	2014533513	A	12/2014
JP	2015521847		8/2015
JP	D 1611654	S	8/2021
KR	100178388	B1	2/1999
KR	1020010089445		10/2001
KR	100495099	B1	11/2005
RU	2600092	C2	12/2012
WO	WO 92/19081	A1	10/1992
WO	WO 94/06314	A1	3/1994
WO	WO 97/41744		11/1997
WO	WO 97/48295	A	12/1997
WO	WO 99/20939	A1	4/1999
WO	WO 00/27232	A1	5/2000
WO	WO 01/70054	A1	9/2001
WO	WO 2007/039794	A2	4/2007
WO	WO 2010/047389	A	4/2010
WO	WO 2013/025921	A1	2/2013
WO	WO 2013/034460	A1	3/2013
WO	WO 2013/076098	A2	5/2013
WO	WO 2013/098396	A2	7/2013
WO	WO 2013/098397		7/2013
WO	WO 2013/160112	A2	10/2013
WO	WO 2015/062983	A2	5/2015

WO	WO 2015/091258	A1	6/2015
WO	WO 2015/166245	A2	11/2015
WO	WO 2016/012774	A1	1/2016
WO	WO 2016/207407	A1	12/2016
WO	WO 2017/194762	A1	11/2017
WO	WO 2017/194763	A2	11/2017
WO	WO 2017/194764	A1	11/2017
WO	WO 2017/194766	A1	11/2017
WO	WO 2017/194769	A1	11/2017
WO	WO 2018/019786	A1	2/2018
WO	004729507-0009	*	8/2020

OTHER PUBLICATIONS

QOQ Honor and Smart. By HKL Reviews. Dated Mar. 15, 2019. Found online [Feb. 3, 2021]. <https://www.youtube.com/watch?v=veLv8NX6smE> (Year: 2019).*

Design U.S. Appl. No. 29/557,914, filed Mar. 14, 2016 inventors Powell et al.

Design U.S. Appl. No. 29/676,726, filed Jan. 14, 2019 inventors Powell et al.

Design U.S. Appl. No. 29/687,464, filed Apr. 12, 2019 inventors Powell et al.

Design U.S. Appl. No. 29/687,469, filed Apr. 12, 2019 inventors Powell et al.

Design U.S. Appl. No. 29/687,471, filed Apr. 12, 2019 inventors Powell et al.

Design U.S. Appl. No. 29/687,461, filed Apr. 12, 2019 inventors Powell et al.

Russian Decision to Grant for Russian Application No. 2016503074/49 dated Jan. 18, 2017.

Uranaka et al., British American Tobacco to test tobacco e-cigarette in Japan, posted on Nov. 8, 2016, [online], [site visited on Apr. 7, 2017]. Available from Internet, <URL: <http://www.reuters.com/article/us-brit-am-tobacco-ecigarettes-idUSKBKN1330AG>>.

International Search Report for International Application No. PCT/EP2016/064756, dated Oct. 5, 2016.

International Search Report and Written Opinion for International Application No. PCT/EP2017/061520, dated Sep. 11, 2017.

International Preliminary Report on Patentability for International Application No. PCT/EP2017/061520, dated Jul. 17, 2018.

English Translation of Korean Office Action for Korean Application No. 10-2017-7037332 dated Dec. 25, 2018.

Notice of Reasons for Refusal and English Translation thereof for Japanese Application No. 2017-567106 dated Nov. 20, 2018.

English Translation of Japanese Office Action for Japanese Application No. 2018-555932 dated Mar. 10, 2020.

English Translation of Chinese Office Action for Chinese Application No. 201680037678.4 dated Jan. 6, 2020.

English Translation of Chinese Search Report for Chinese Application No. 201680037678.4 dated Dec. 25, 2019.

International Search Report for International Application No. PCT/EP2017/061518, dated Aug. 1, 2017.

International Preliminary Report on Patentability for International Application No. PCT/EP2017/061518, dated Aug. 17, 2018.

Russian Office Action for Russian Application No. 2018139838/07 dated Jun. 28, 2019.

Japanese Office Action for Japanese Application No. 2018-554501 dated Feb. 25, 2020.

International Search Report for International Application No. PCT/EP2017/061526, dated Aug. 2, 2017.

English Translation of Japanese Office Action for Japanese Application No. 2018-554526 dated Feb. 25, 2020.

International Search Report and Written Opinion for International Application No. PCT/EP2017/061523, dated Sep. 11, 2017.

International Preliminary Report on Patentability for International Application No. PCT/EP2017/061523, dated Jul. 23, 2018.

Indian Office Action for Indian Application No. 201847042184 dated Jan. 10, 2020.

Japanese Office Action for Japanese Application No. 2018-551932 dated Jan. 28, 2020.

International Preliminary Report on Patentability for International Application No. PCT/EP2017/068675, dated Aug. 27, 2018.

International Search Report and Written Opinion for International Application No. PCT/EP2017/068675, dated Nov. 9, 2017.
 International Preliminary Report on Patentability for International Application No. PCT/EP2017/061519, dated Jul. 25, 2018.
 International Search Report and Written Opinion for International Application No. PCT/EP2017/061519, dated Dec. 15, 2017.
 Japanese Office Action for Japanese Application No. 2018-559712 dated Feb. 18, 2020.
 Glo E-cigarette, published 2016 [online], Available from Internet, URL: <https://ifworlddesignguide.com/entry/235574-glo> on retrieved Dec. 5, 2020, 4 pages.
 Office Action dated Jun. 4, 2020 for Russian Application No. 2019504647, 11 pages.
 Japanese Office Action for Japanese Application No. 2019-020616, dated Jan. 17, 2022, 2 pages.

* cited by examiner

Primary Examiner — Marissa J Cash
Assistant Examiner — William B Melliar
 (74) *Attorney, Agent, or Firm* — Patterson Thuente Pedersen, P.A.

(57) **CLAIM**

We claim the ornamental design for an aerosol generator, as shown and described.

DESCRIPTION

FIG. 1 is a top front perspective view of an aerosol generator according to an embodiment.
 FIG. 2 is a front elevational view of the aerosol generator depicted in FIG. 1.
 FIG. 3 is a rear elevational view of the aerosol generator depicted in FIG. 1.
 FIG. 4 is a right side elevational view of the aerosol generator depicted in FIG. 1.
 FIG. 5 is a left side elevational view of the aerosol generator depicted in FIG. 1.
 FIG. 6 is a top plan view of the aerosol generator depicted in FIG. 1.

FIG. 7 is a bottom plan view of the aerosol generator depicted in FIG. 1.

FIG. 8 is a bottom rear perspective view of the aerosol generator depicted in FIG. 1.

FIG. 9 is a top front perspective view of an aerosol generator according to a second embodiment.

FIG. 10 is a front elevational view of the aerosol generator depicted in FIG. 9.

FIG. 11 is a rear elevational view of the aerosol generator depicted in FIG. 9.

FIG. 12 is a right side elevational view of the aerosol generator depicted in FIG. 9.

FIG. 13 is a left side elevational view of the aerosol generator depicted in FIG. 9.

FIG. 14 is a top plan view of the aerosol generator depicted in FIG. 9.

FIG. 15 is a bottom plan view of the aerosol generator depicted in FIG. 9.

FIG. 16 is a bottom rear perspective view of the aerosol generator depicted in FIG. 9.

FIG. 17 is a top front perspective view of an aerosol generator according to a third embodiment.

FIG. 18 is a front elevational view of the aerosol generator depicted in FIG. 17.

FIG. 19 is a rear elevational view of the aerosol generator depicted in FIG. 17.

FIG. 20 is a right side elevational view of the aerosol generator depicted in FIG. 17.

FIG. 21 is a left side elevational view of the aerosol generator depicted in FIG. 17.

FIG. 22 is a top plan view of the aerosol generator depicted in FIG. 17.

FIG. 23 is a bottom plan view of the aerosol generator depicted in FIG. 17; and,

FIG. 24 is a bottom rear perspective view of the aerosol generator depicted in FIG. 17.

The broken lines in the drawings illustrate portions of the aerosol generator that form no part of the claimed design.

1 Claim, 24 Drawing Sheets

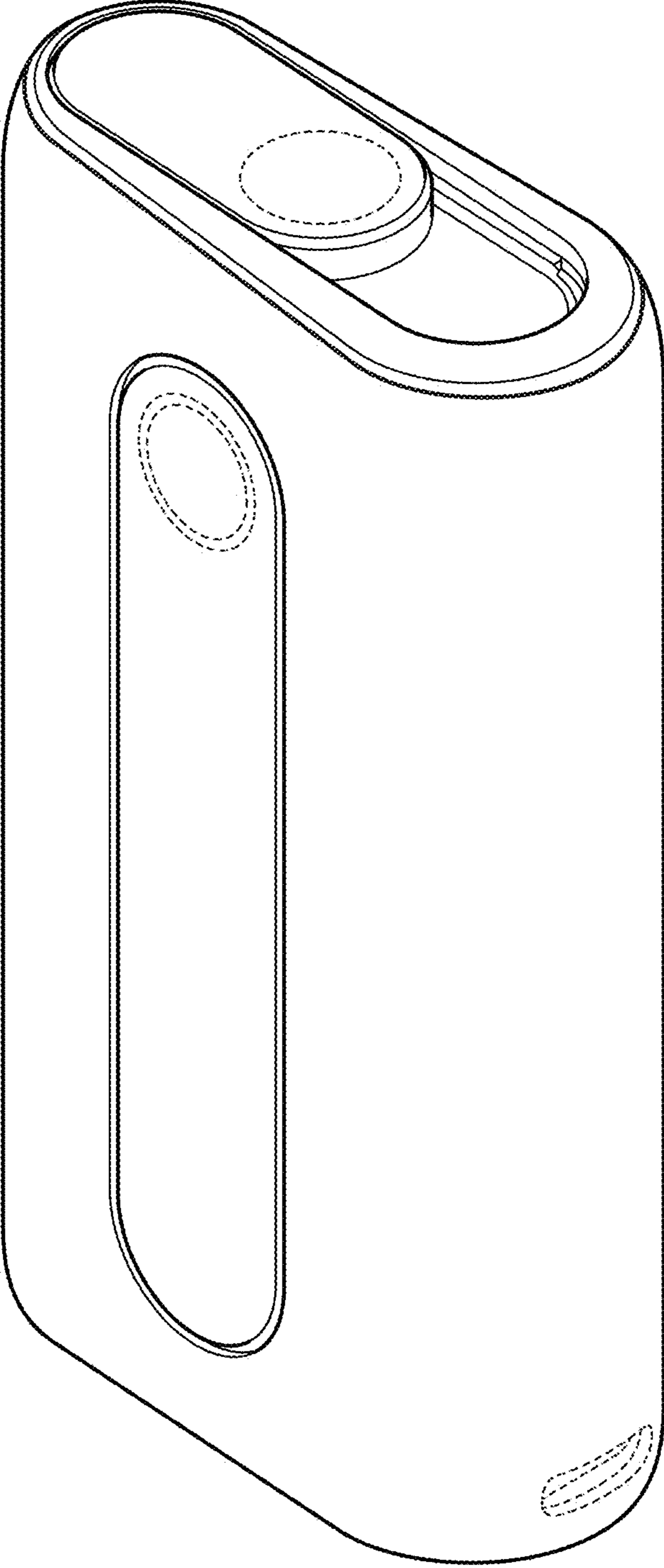

FIG. 1

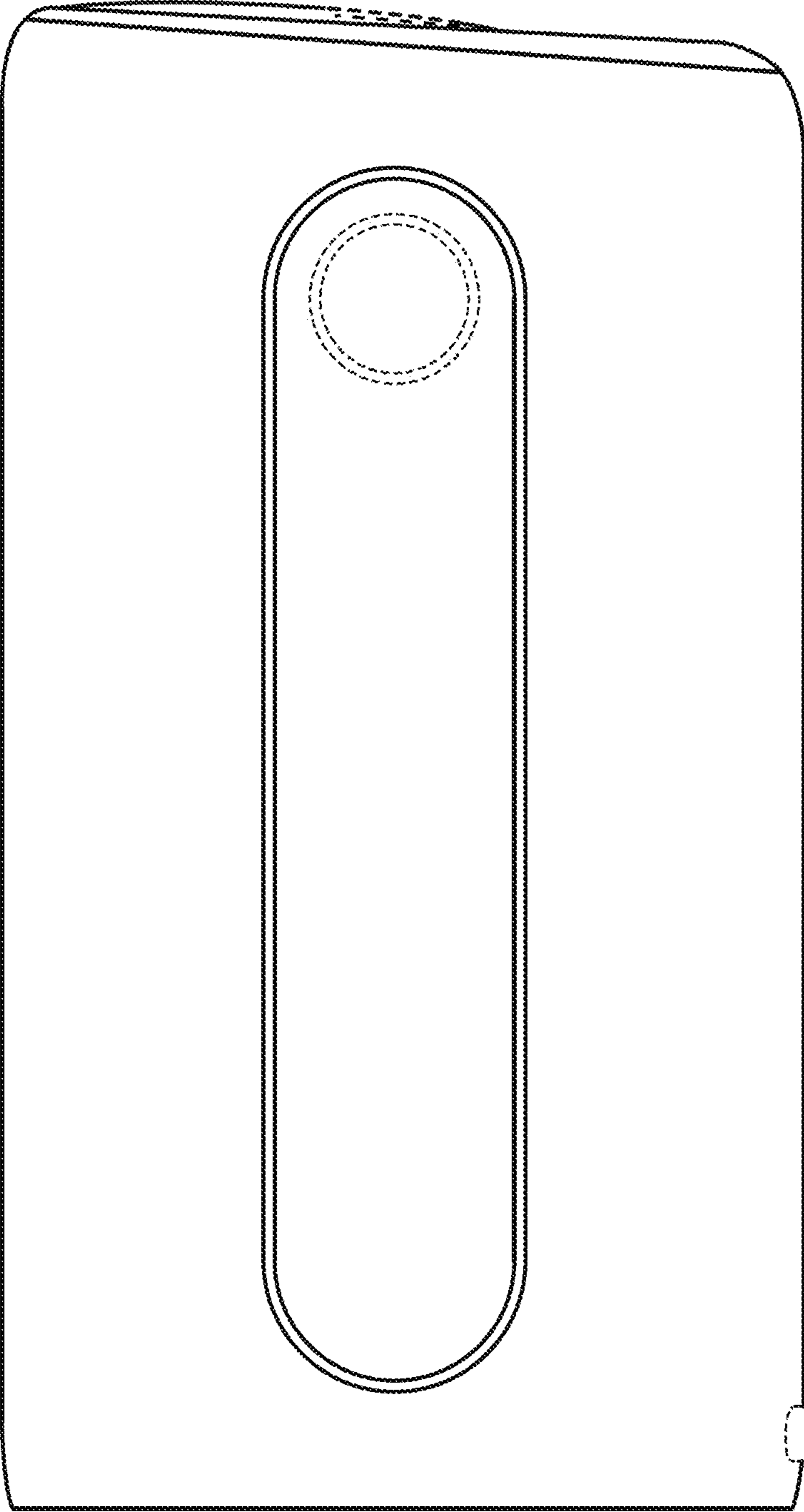

FIG. 2

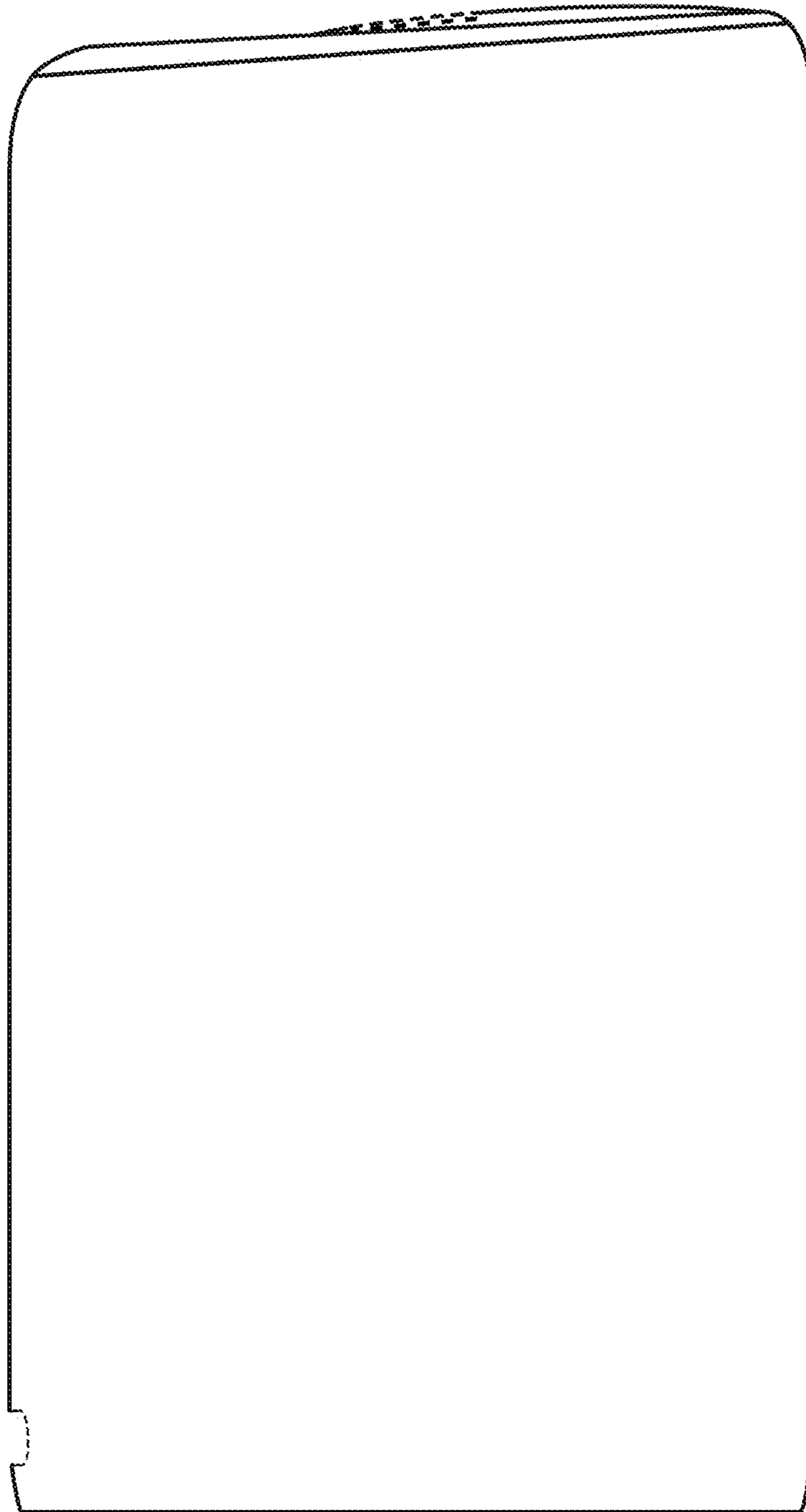

FIG. 3

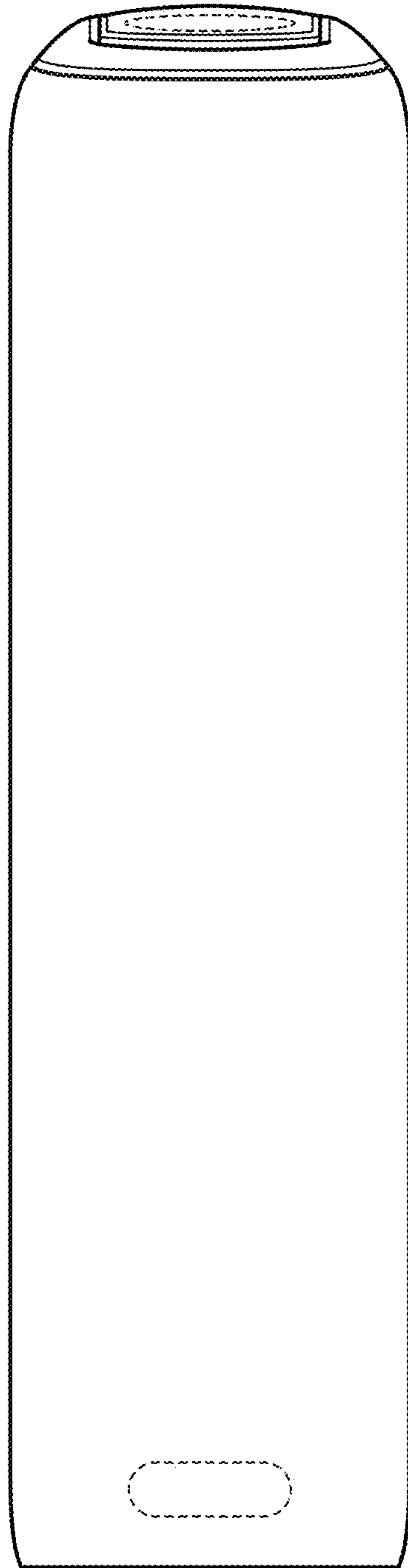

FIG. 4

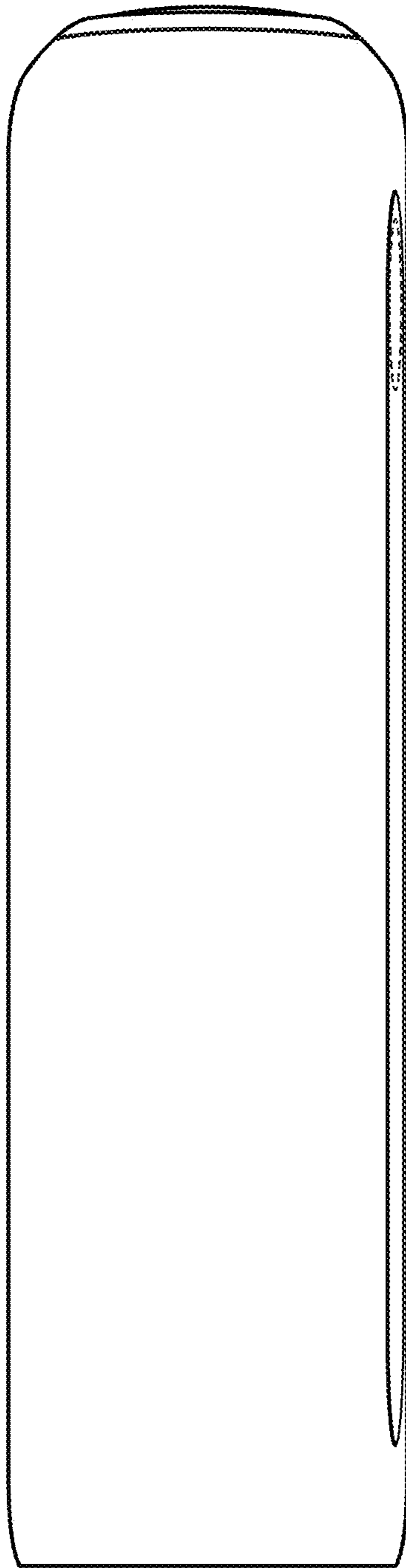

FIG. 5

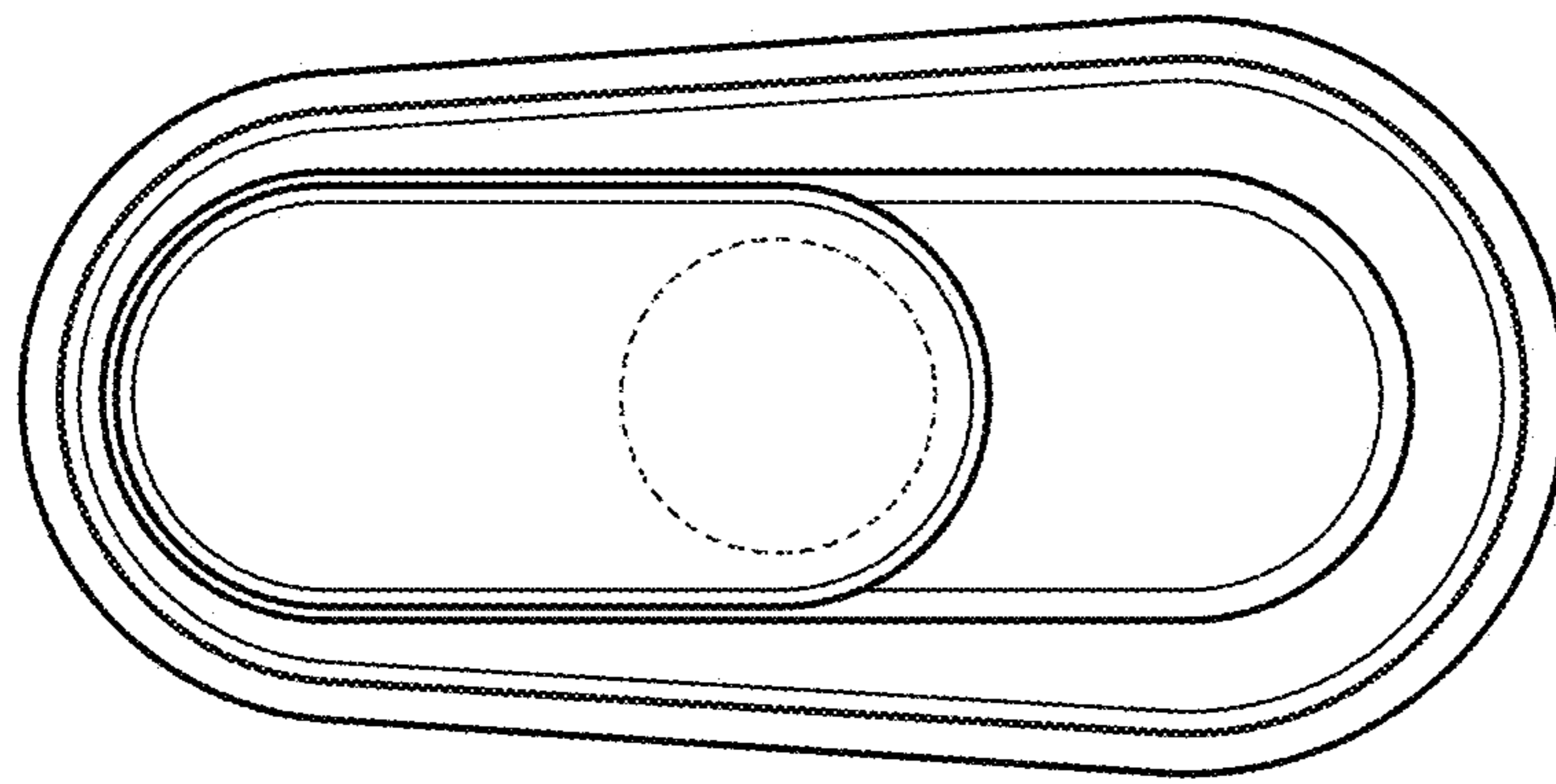

FIG. 6

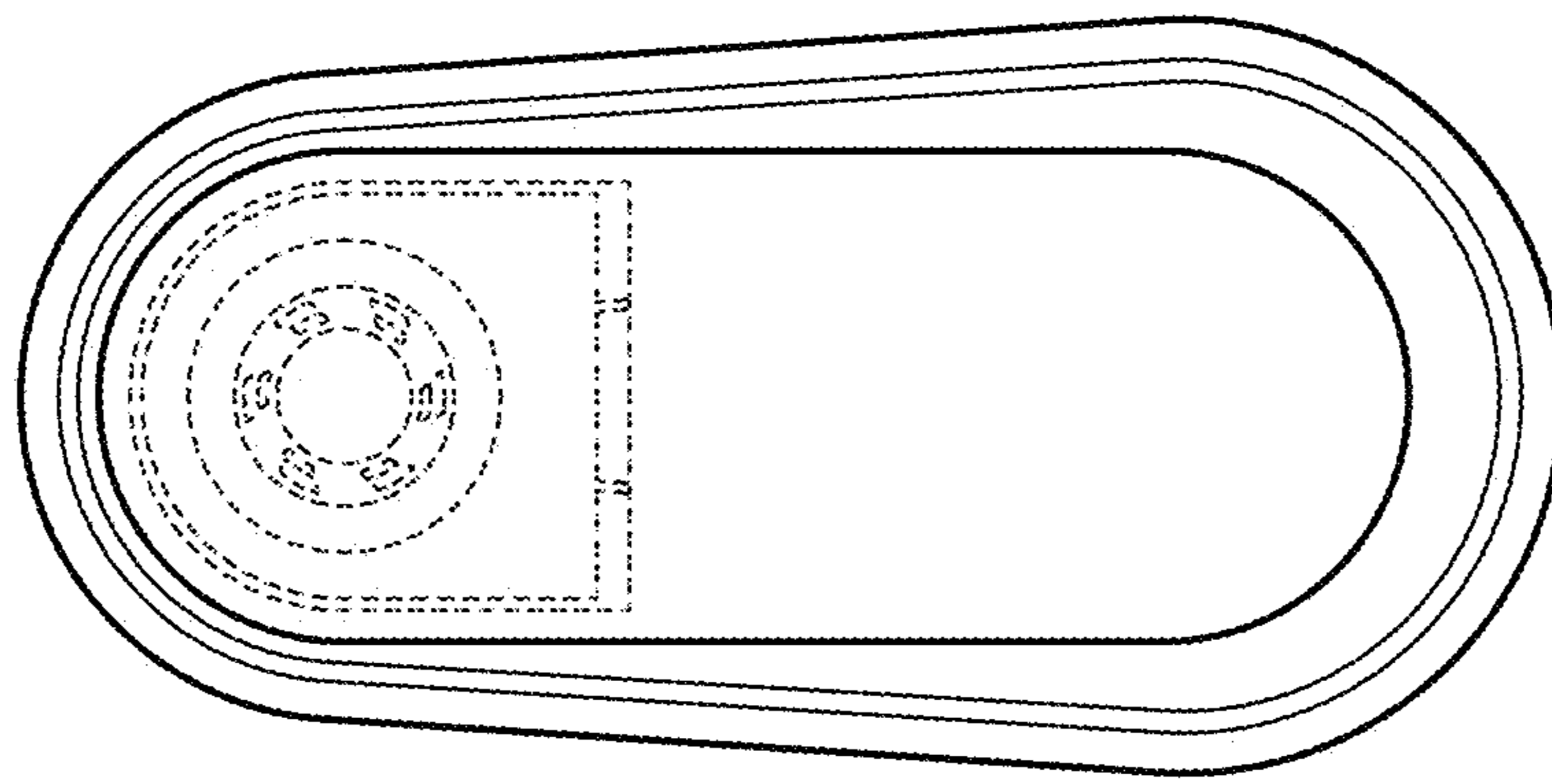

FIG. 7

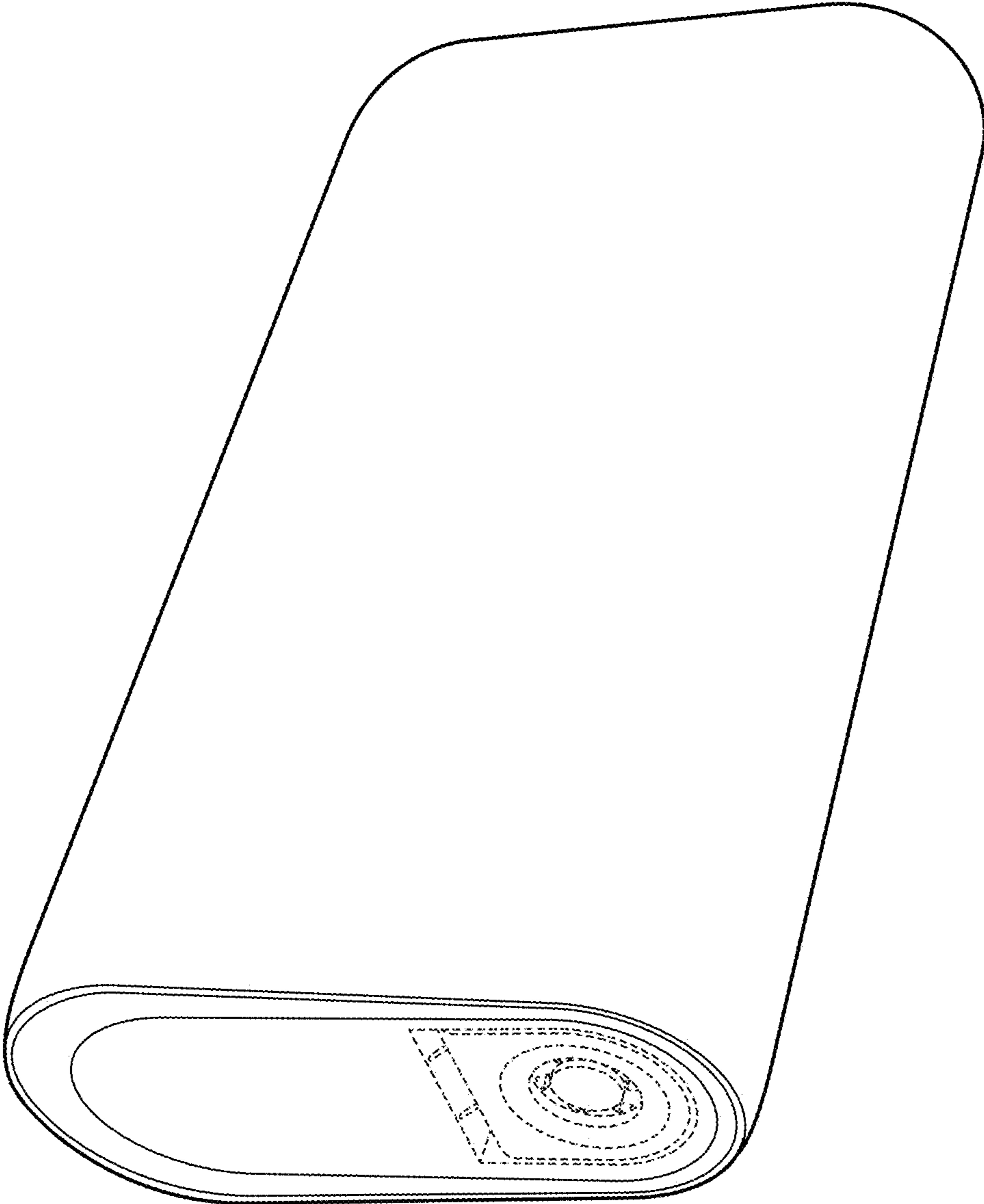

FIG. 8

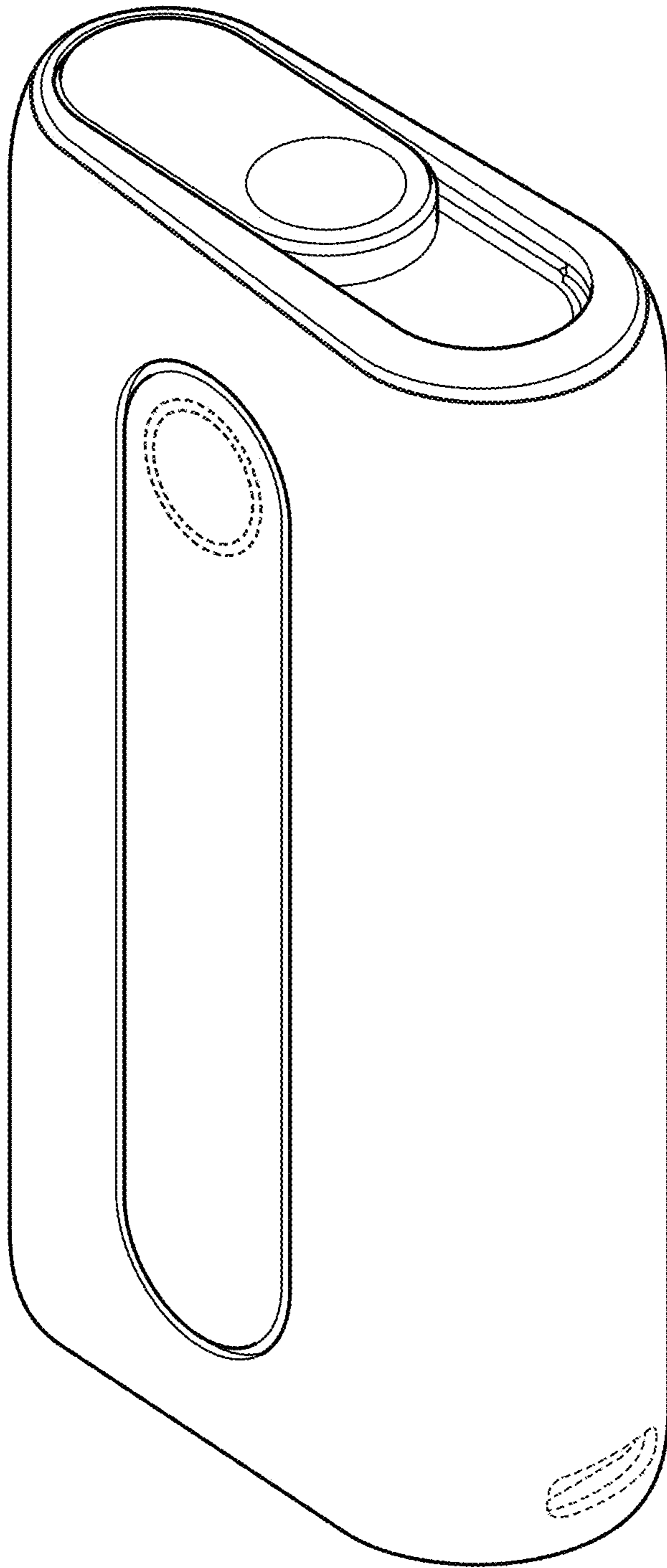

FIG. 9

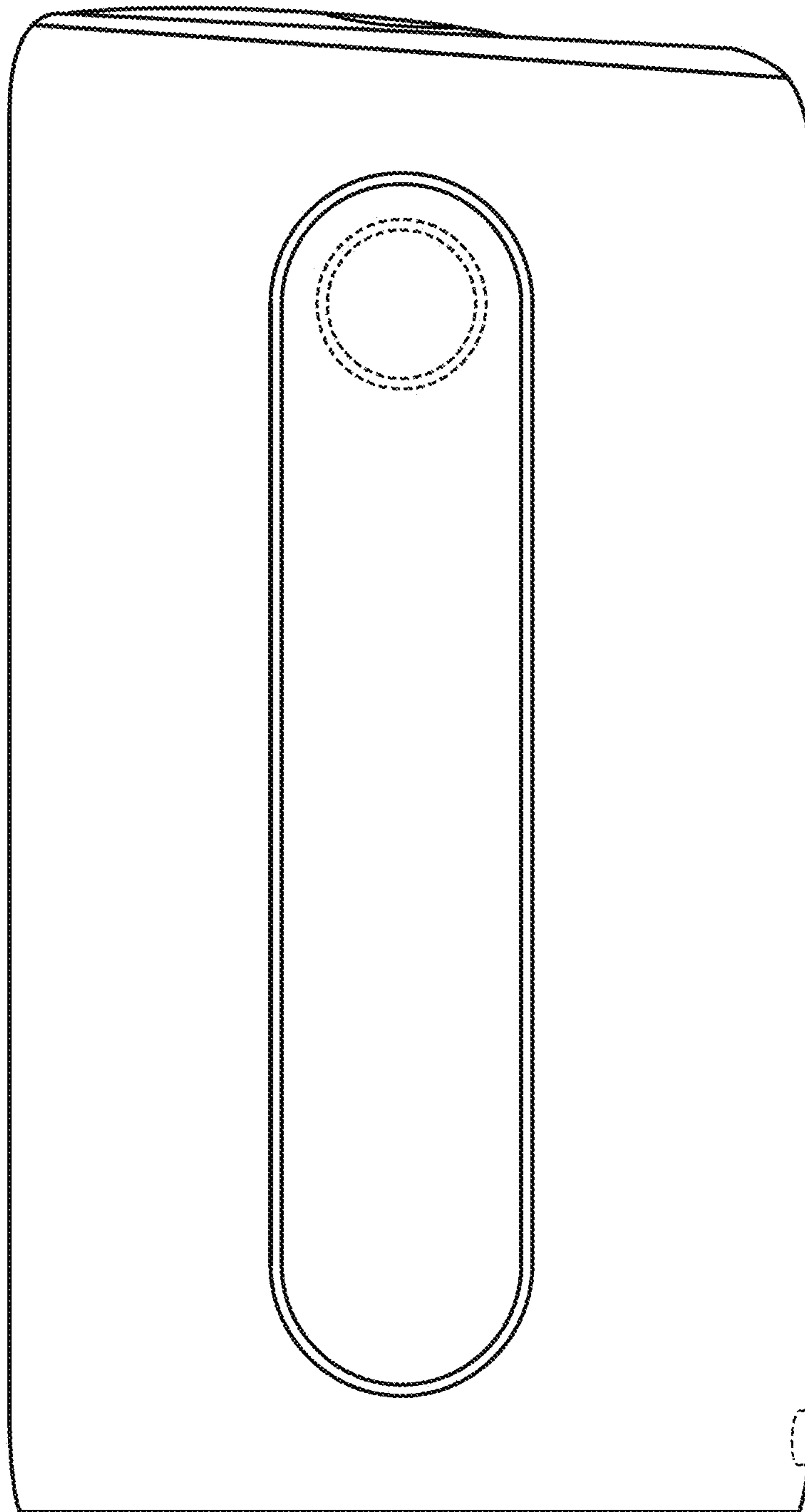

FIG. 10

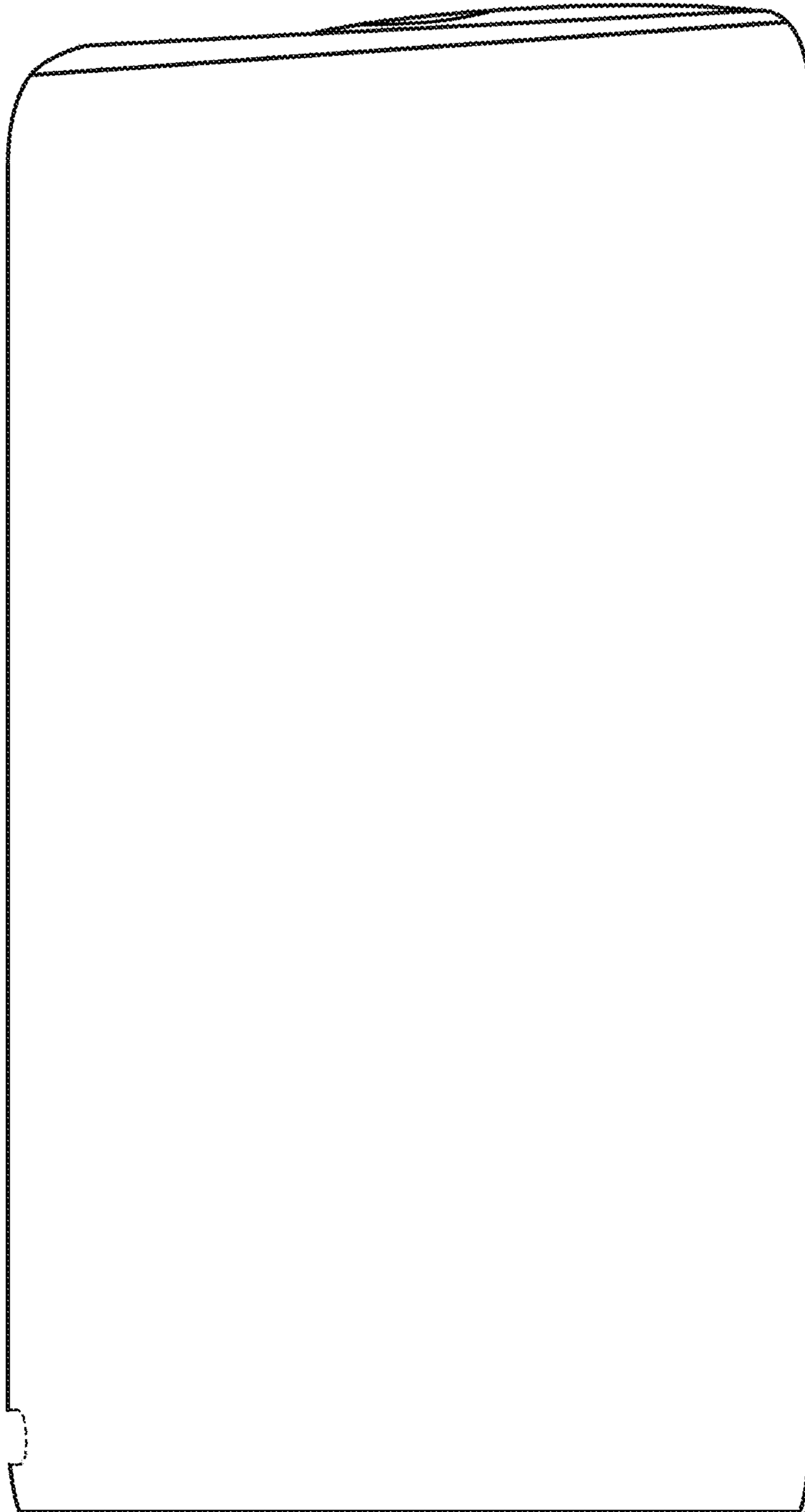

FIG. 11

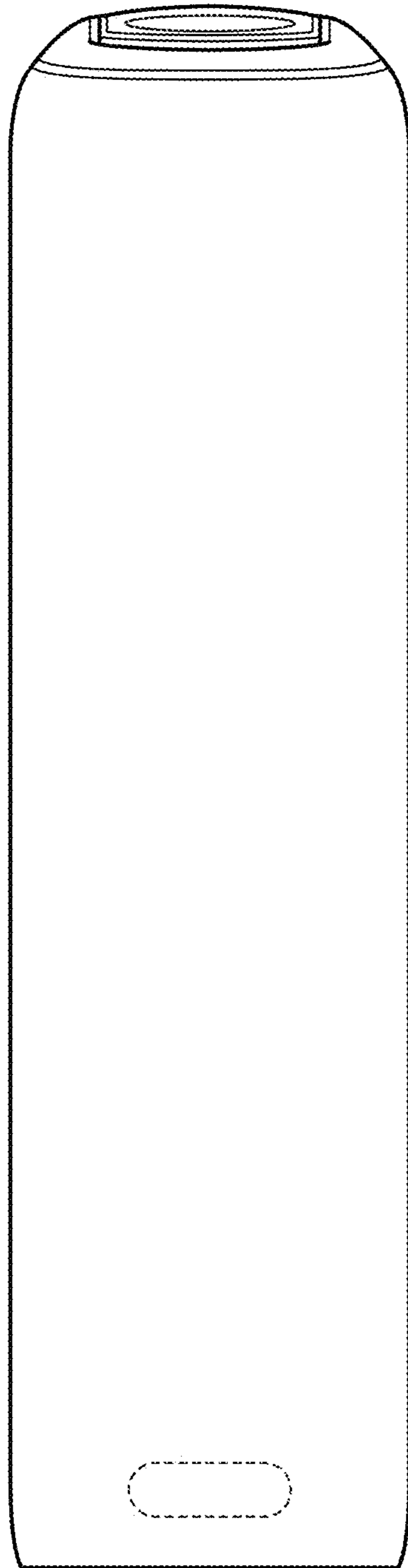

FIG. 12

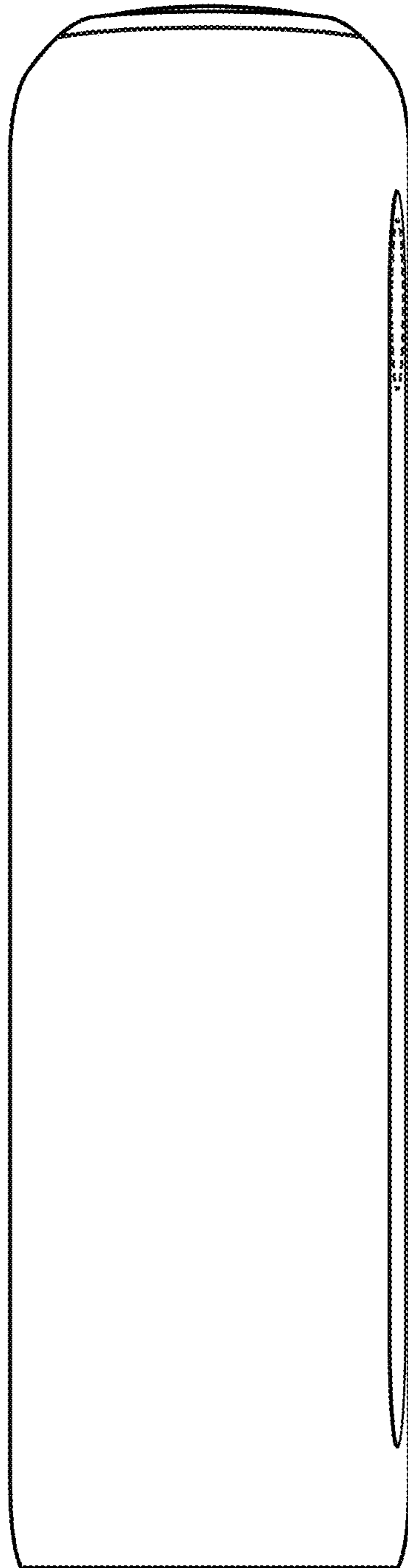

FIG. 13

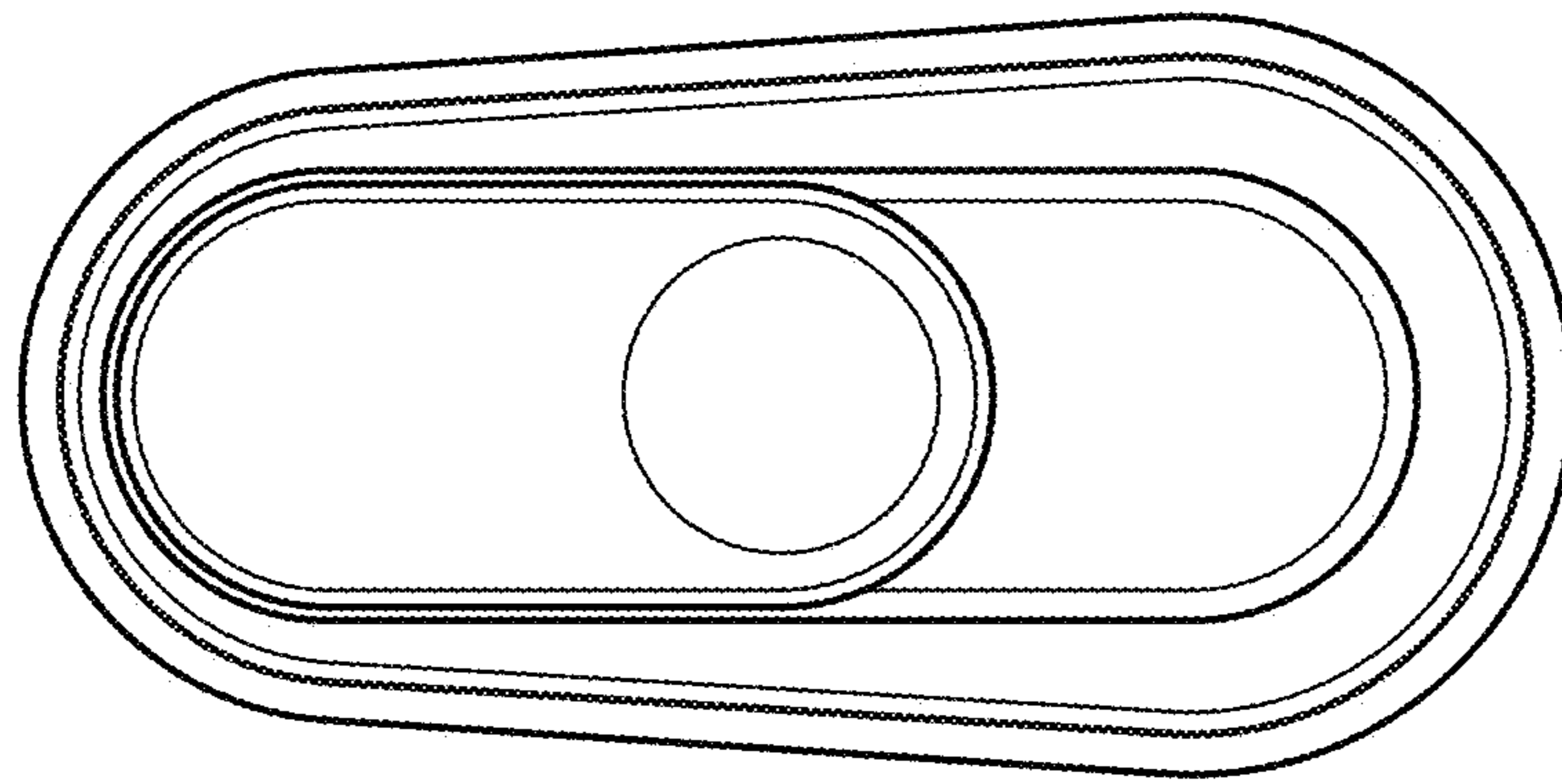

FIG. 14

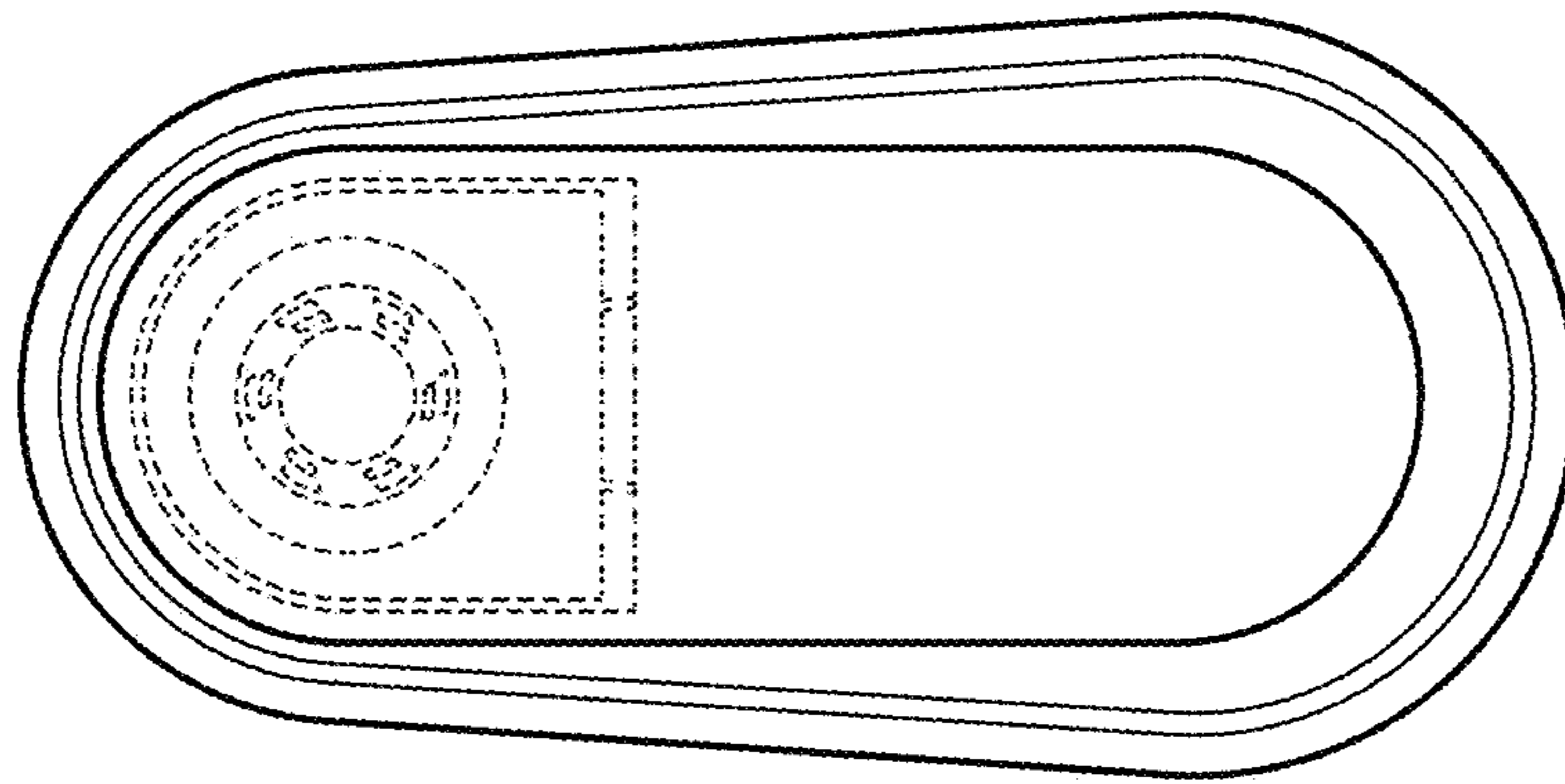

FIG. 15

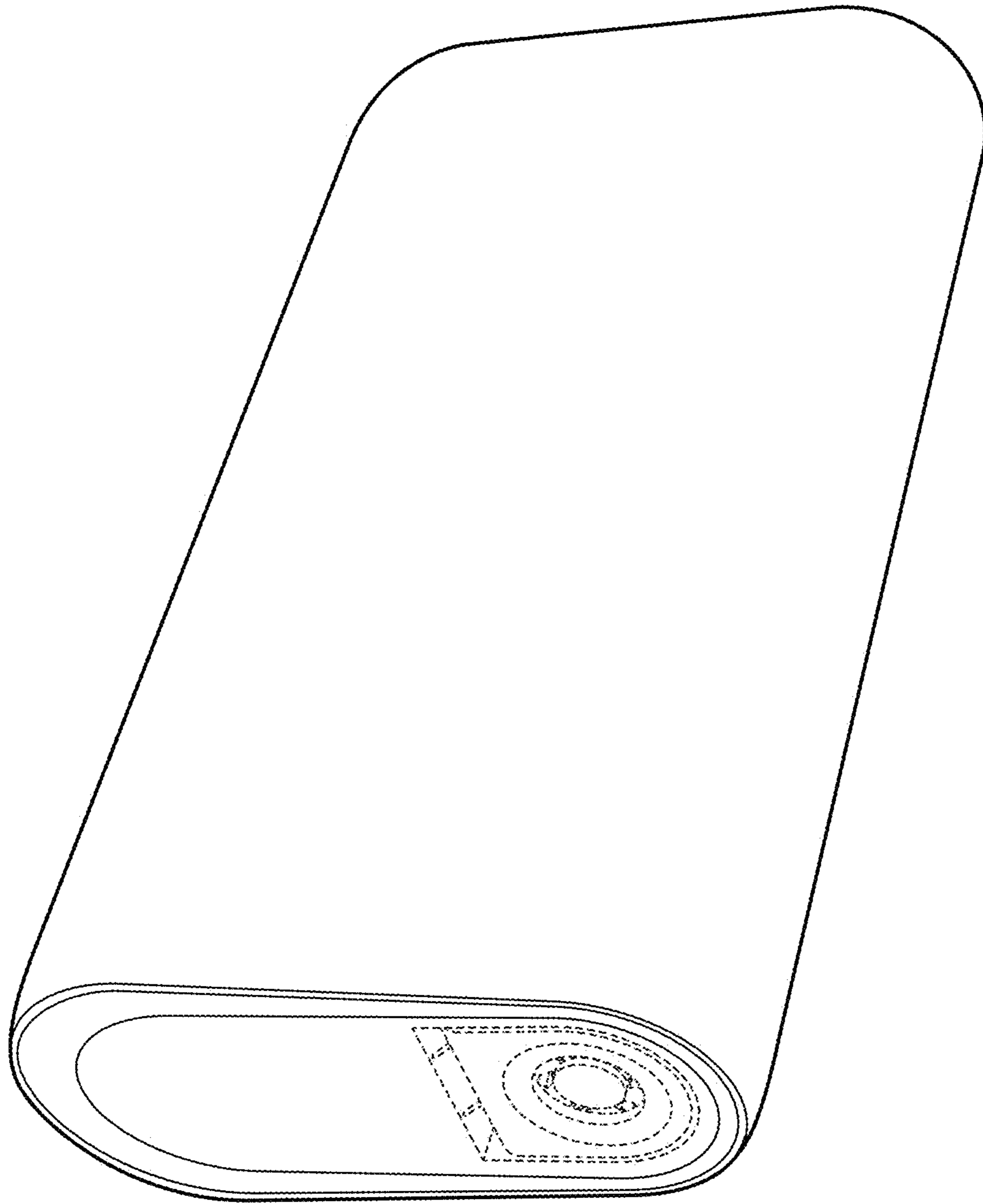

FIG. 16

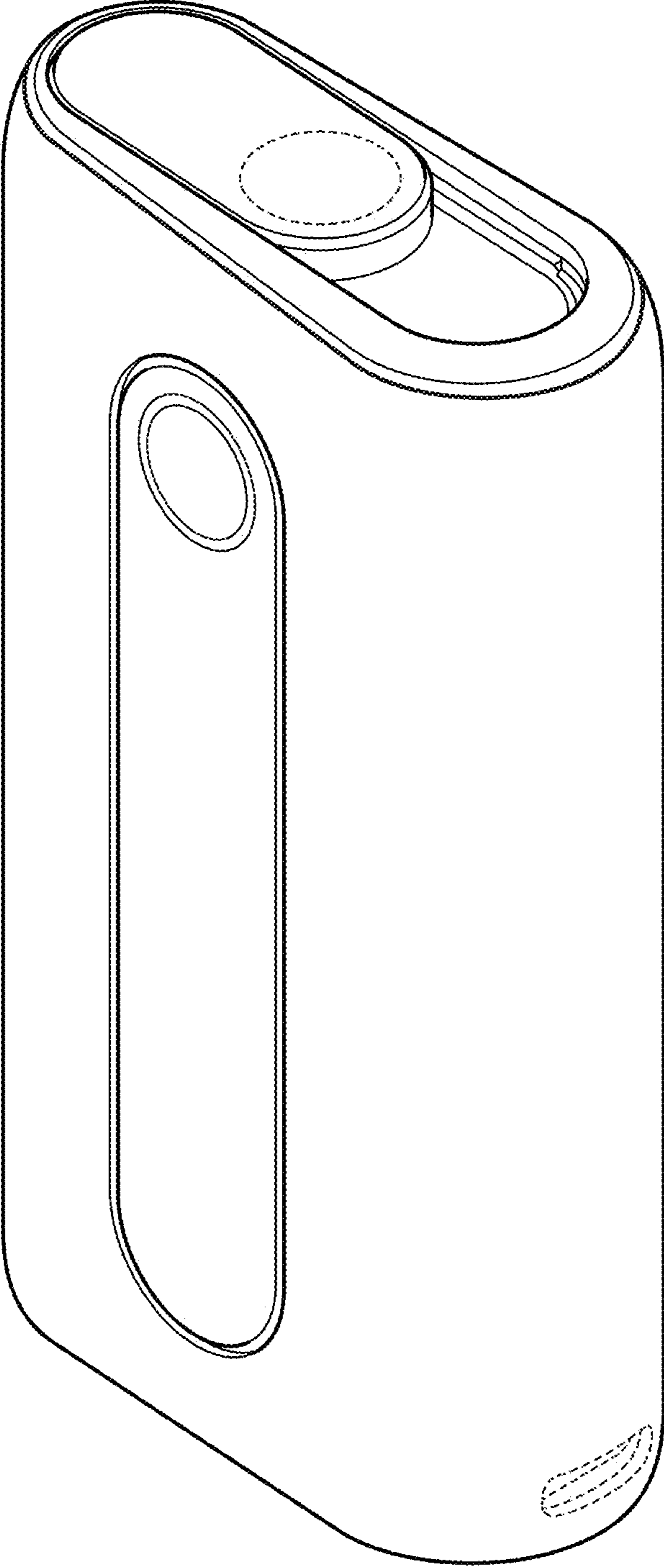

FIG. 17

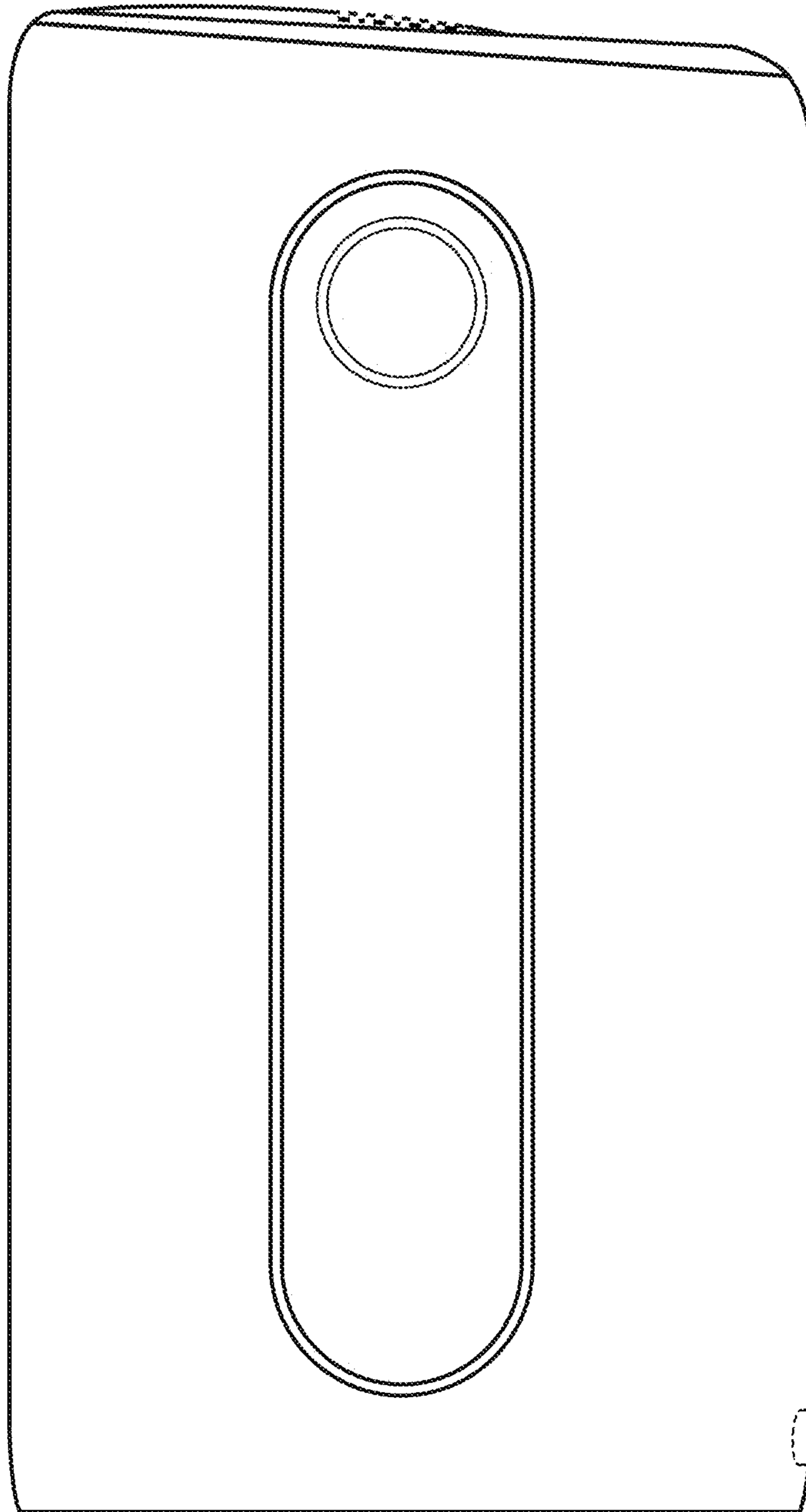

FIG. 18

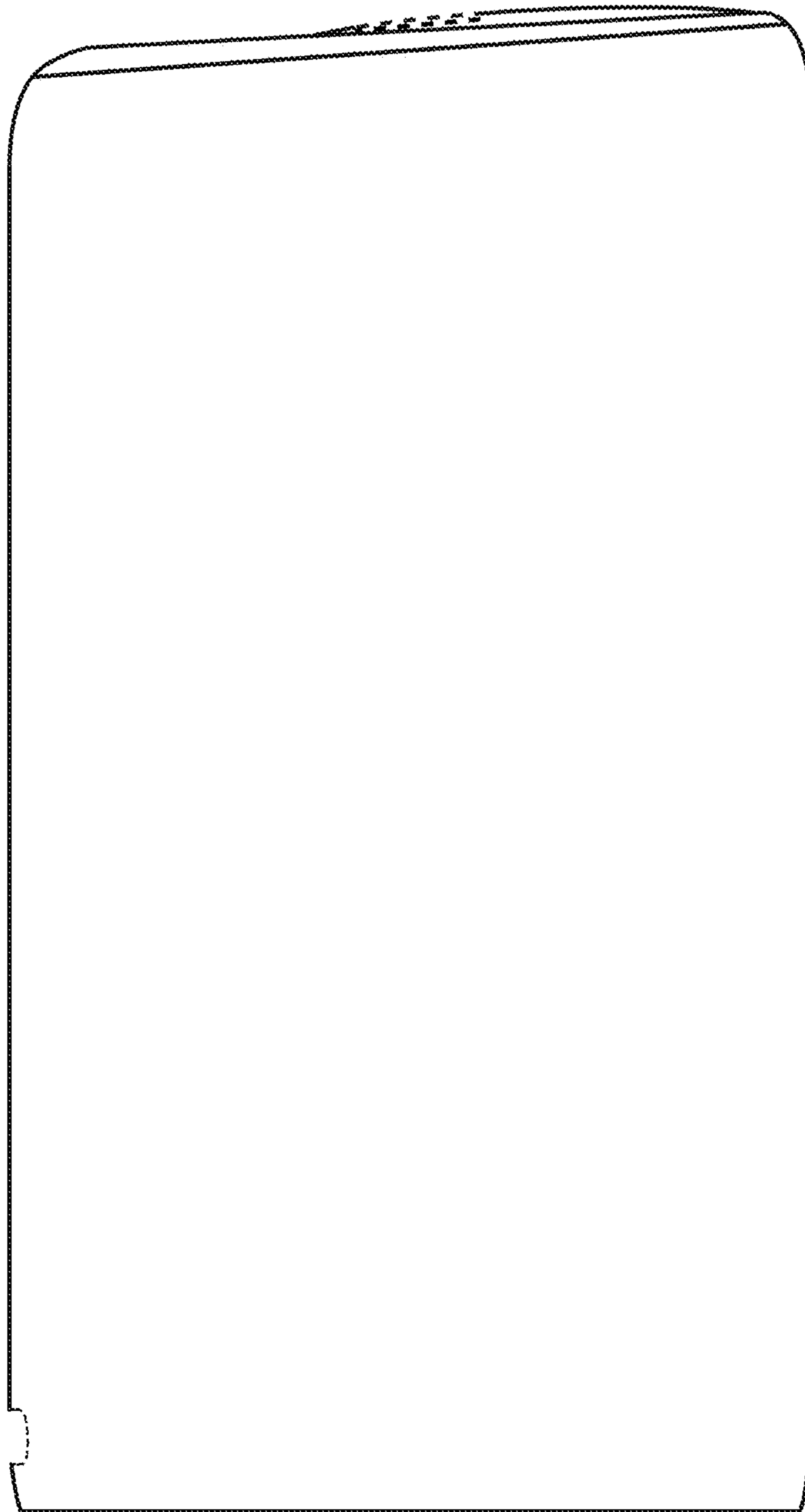

FIG. 19

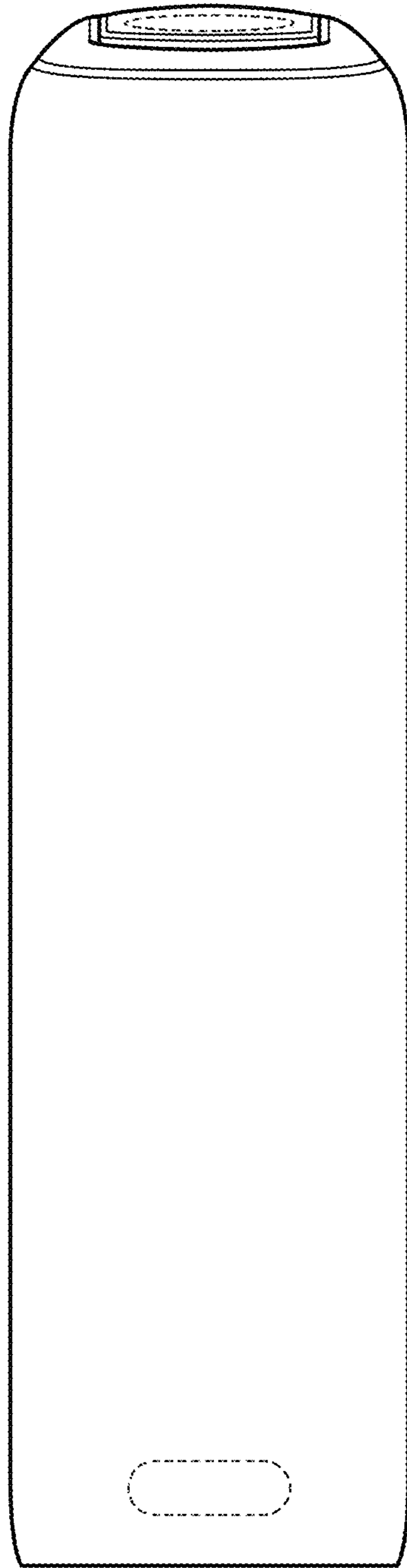

FIG. 20

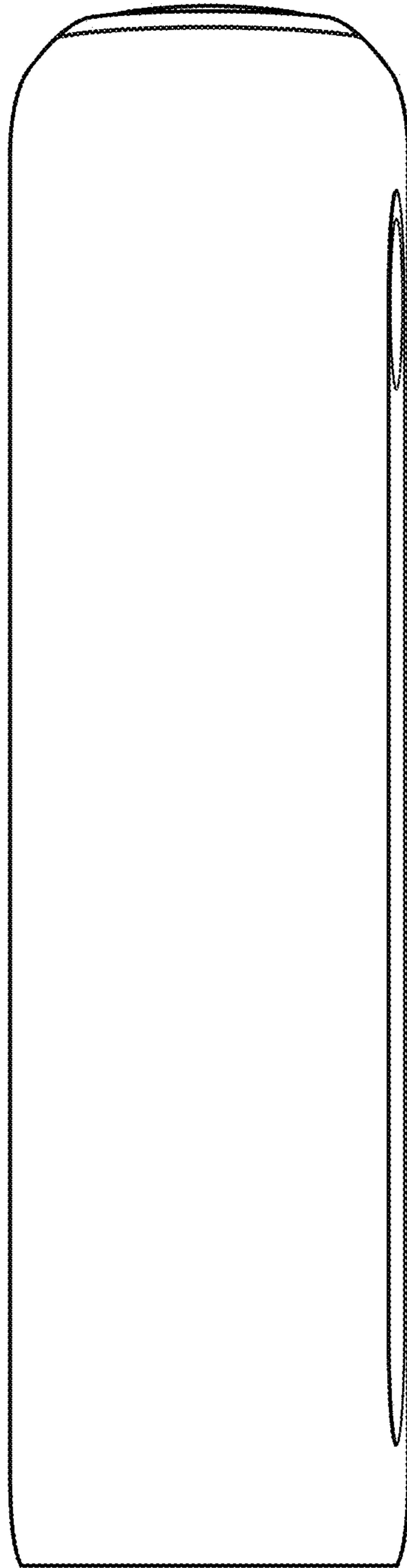

FIG. 21

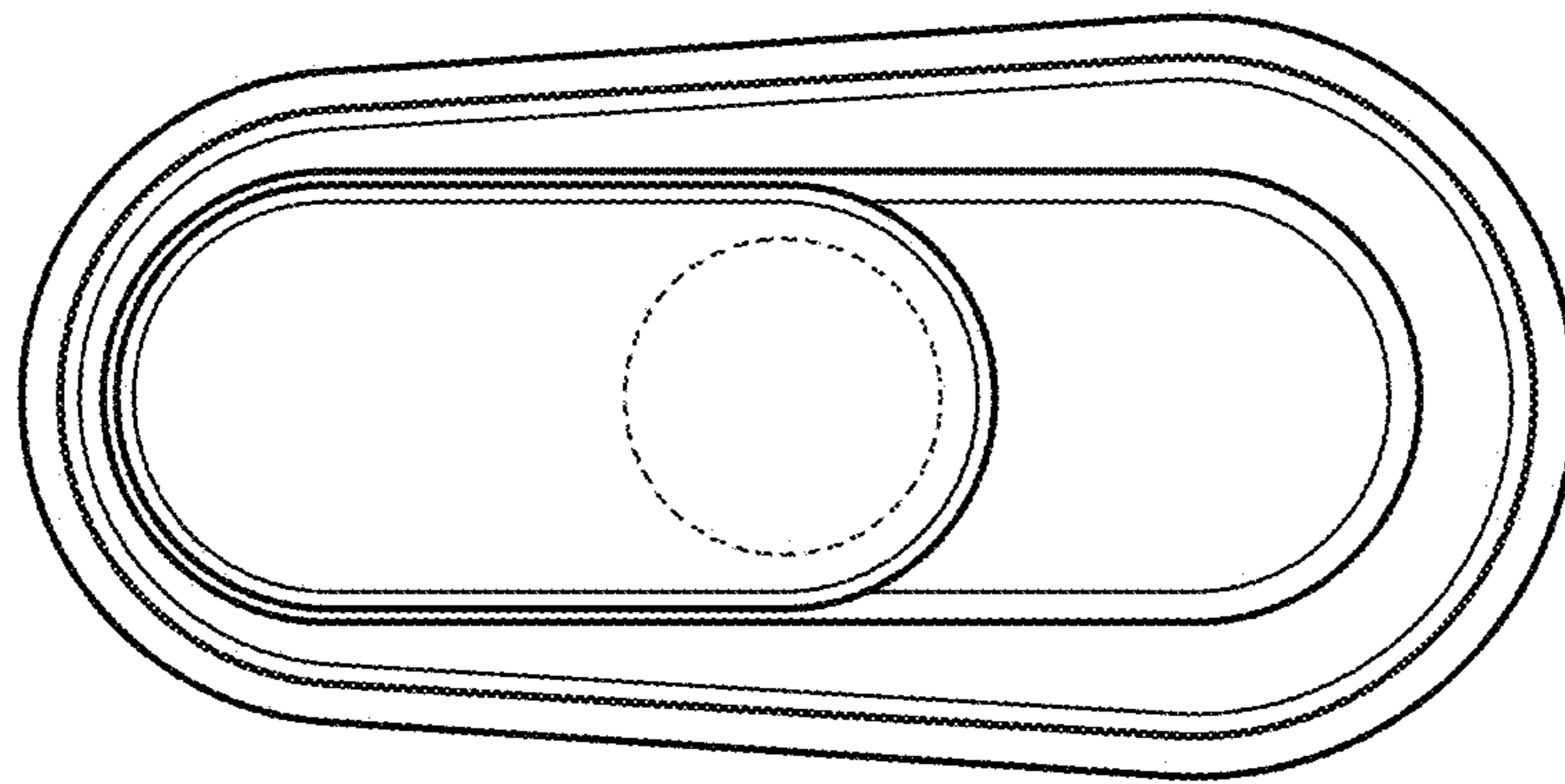

FIG. 22

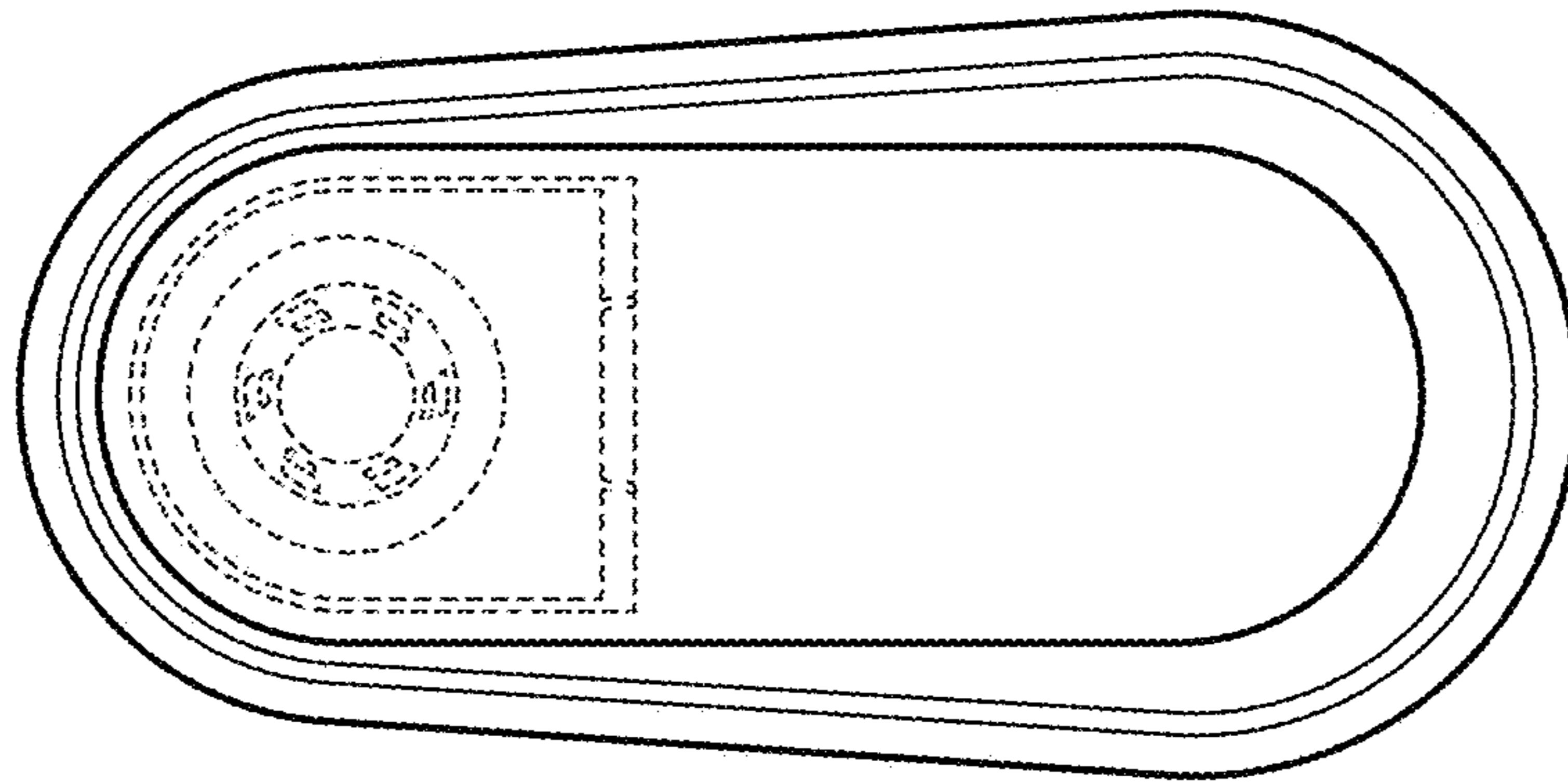

FIG. 23

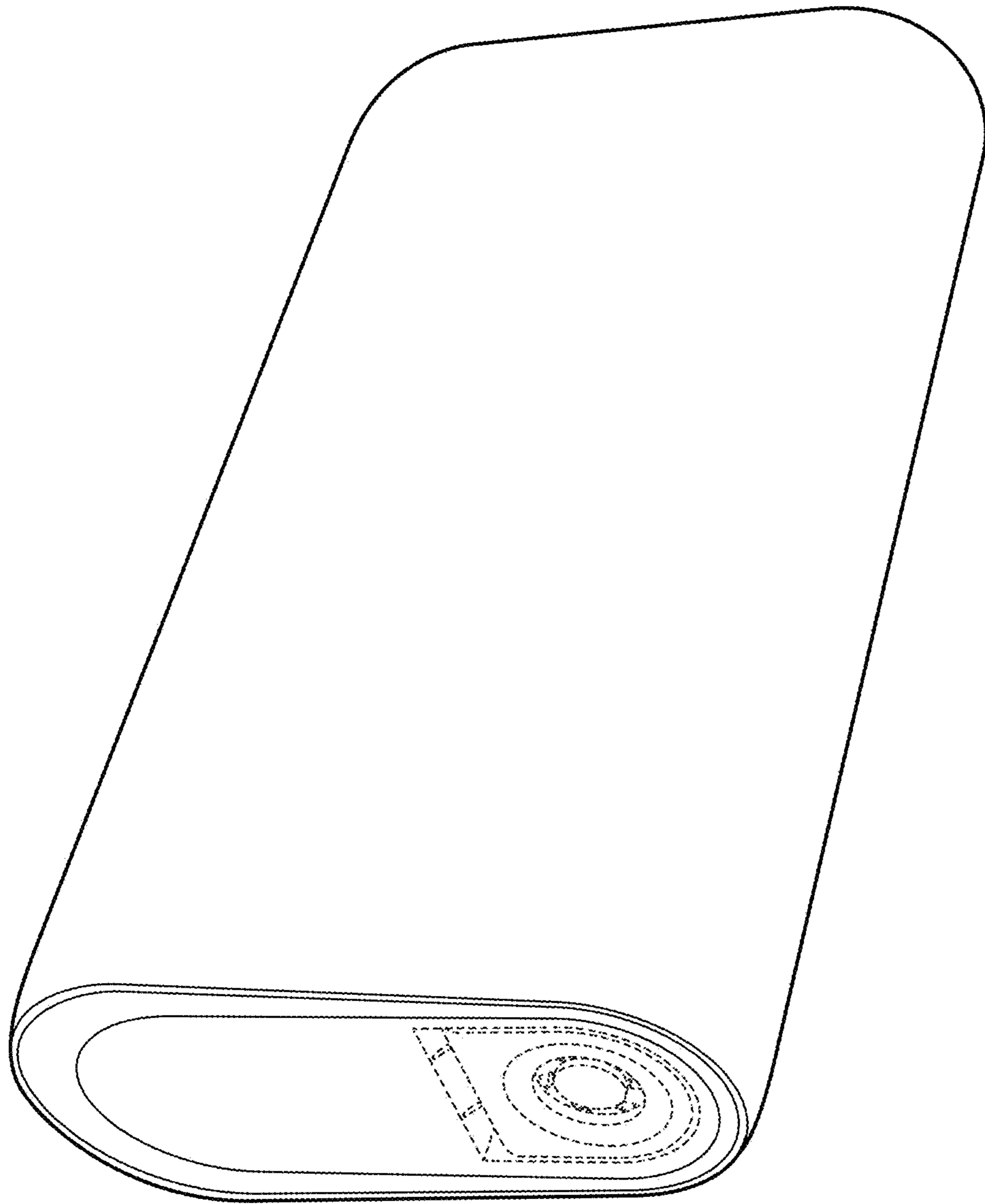

FIG. 24