



US00D953392S

(12) **United States Design Patent** (10) **Patent No.:** **US D953,392 S**
Karlsson et al. (45) **Date of Patent:** **** May 31, 2022**

(54) **MILLING CUTTER TOOL**
(71) Applicant: **SECO TOOLS AB**, Fagersta (SE)
(72) Inventors: **Kent Karlsson**, Fellingsbro (SE);
Rikard Flodman, Arboga (SE)
(73) Assignee: **Seco Tools AB**, Fagersta (SE)
(**) Term: **15 Years**
(21) Appl. No.: **29/819,827**
(22) Filed: **Dec. 17, 2021**

Related U.S. Application Data

(62) Division of application No. 29/689,529, filed on Apr. 30, 2019.

Foreign Application Priority Data

Jan. 25, 2019 (EM) 006084224-0001
Jan. 25, 2019 (EM) 006084224-0003
Jan. 25, 2019 (EM) 006084224-0004
Jan. 25, 2019 (EM) 006084224-0006

(51) **LOC (13) Cl.** **15-09**
(52) **U.S. Cl.**
USPC **D15/139**

(58) **Field of Classification Search**
USPC D8/20, 70, 71; D15/21, 28, 77, 126,
D15/131-133, 138, 139
CPC B23C 2200/0494; B23C 2200/086; B23C
2200/128; B23C 2200/362; B23C
2210/03; B23C 2210/02; B23B 51/02;
B23B 51/048; E01C 23/088; Y10T
407/23; Y10T 409/30952; A01G 23/067;
B02C 4/305; B02C 7/12; B02C 18/18;
B02C 13/28; B02C 13/2804; B27G
13/00; B27G 13/10; E21B 10/08; E21B
10/43; E21B 10/62; E21B 10/602; E21B
10/55

See application file for complete search history.

(56) **References Cited**
U.S. PATENT DOCUMENTS
D351,174 S * 10/1994 Brady D15/139
D376,158 S * 12/1996 Hessman D15/139
7,252,461 B2 * 8/2007 Karonen B23B 27/16
407/113
D582,448 S * 12/2008 Boulakhov D15/139
7,549,824 B2 * 6/2009 Agic B23B 27/16
407/42
8,430,607 B2 * 4/2013 Jansson B23C 5/06
407/113
8,740,508 B2 * 6/2014 Jansson B23C 5/22
407/40
D717,847 S * 11/2014 Mikado D15/139
8,985,914 B2 * 3/2015 Jansson B23C 5/2406
407/36
9,233,426 B2 * 1/2016 Jansson B23C 5/207
D926,239 S * 7/2021 Flodman D15/139
D926,846 S * 8/2021 Flodman D15/139
D926,847 S * 8/2021 Flodman D15/139

(Continued)

Primary Examiner — Calvin E Vansant
Assistant Examiner — Mark T. Philipps
(74) *Attorney, Agent, or Firm* — Volpe Koenig

(57) **CLAIM**
We claim the ornamental design for a milling cutter tool, as shown and described.

DESCRIPTION

FIG. 1 is a perspective view of a milling cutter tool in accordance with our design;
FIG. 2 is a top plan view thereof;
FIG. 3 is a front elevational view thereof;
FIG. 4 is a right side elevational view thereof;
FIG. 5 is a left side elevational view thereof;
FIG. 6 is a rear elevational view thereof; and,
FIG. 7 is a bottom plan view thereof.

1 Claim, 7 Drawing Sheets

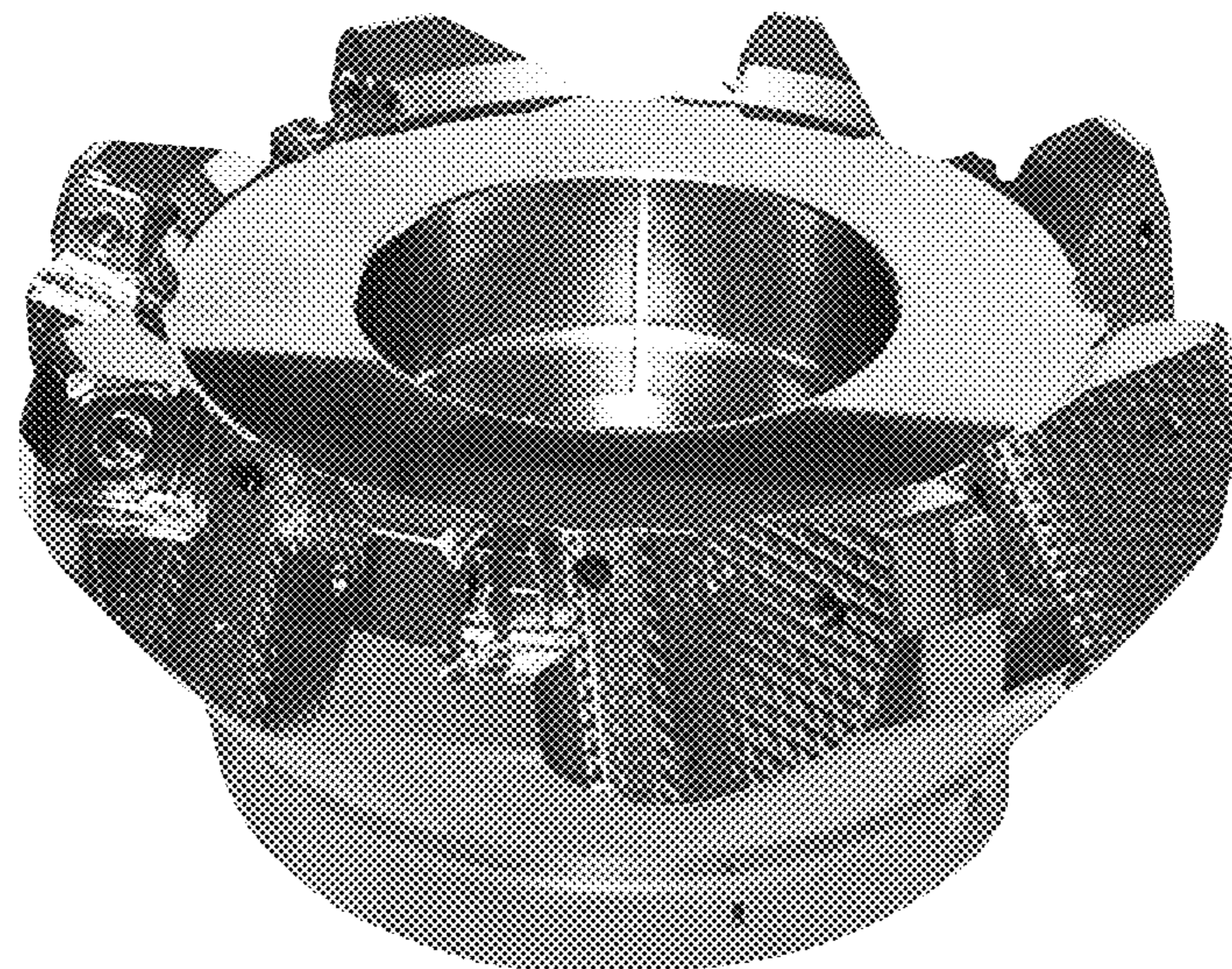

(56)

References Cited

U.S. PATENT DOCUMENTS

2007/0081873 A1* 4/2007 Blomstedt B23C 5/10
409/234
2007/0231088 A1 10/2007 Waggle et al.
2014/0318873 A1* 10/2014 Patel E21B 10/567
175/432
2021/0237176 A1* 8/2021 Flodman B23C 5/006

* cited by examiner

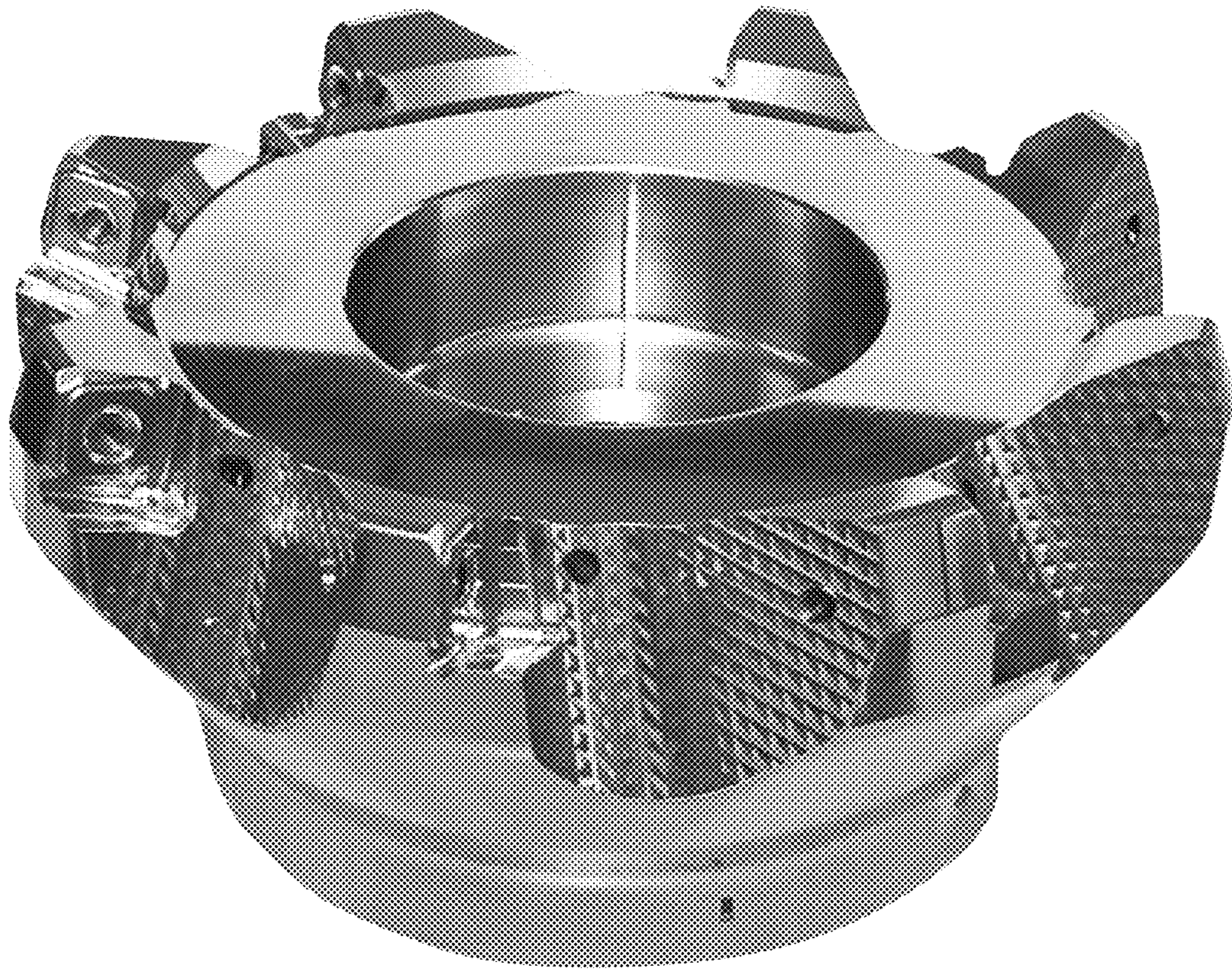

Fig. 1

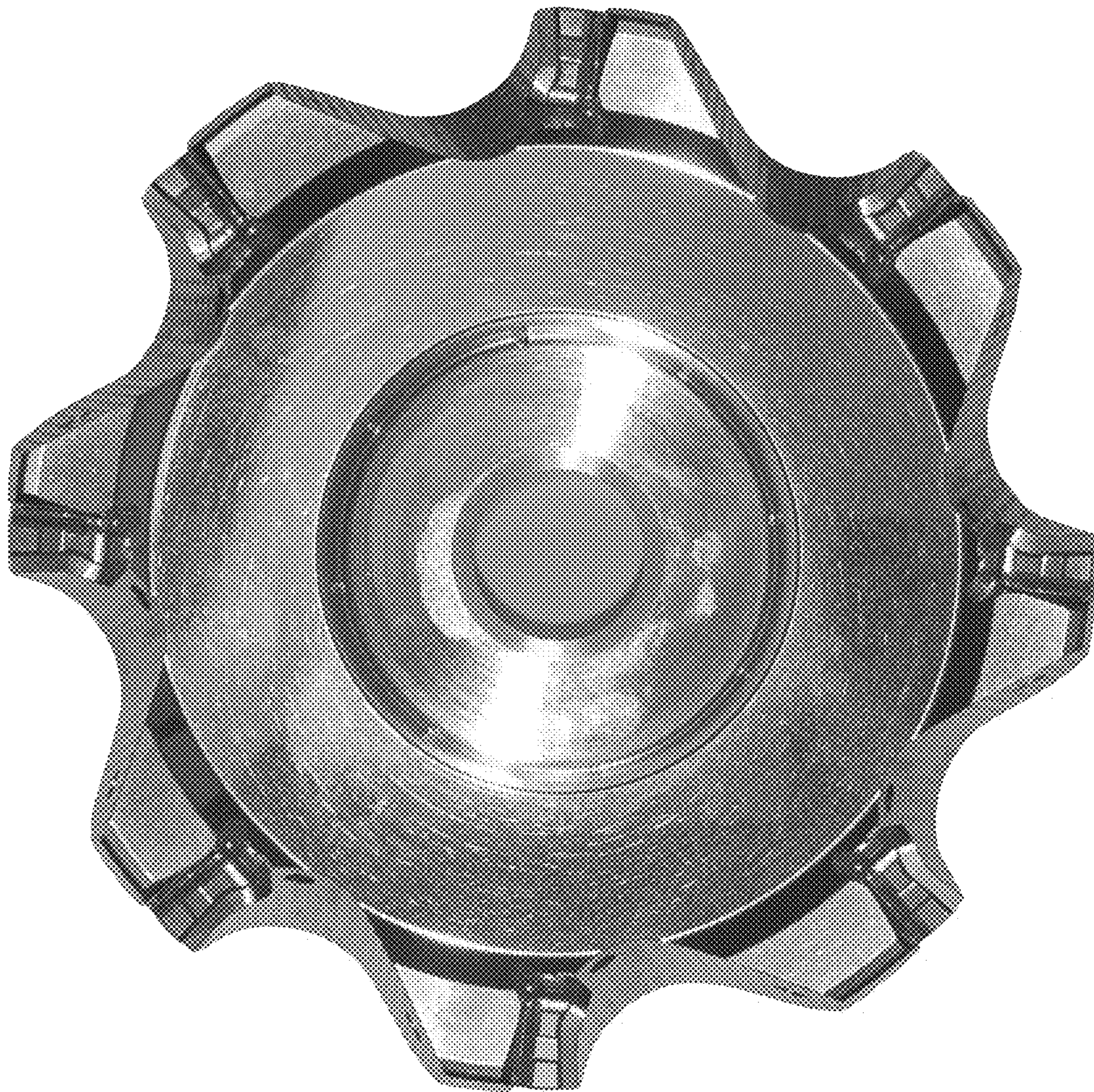

Fig. 2

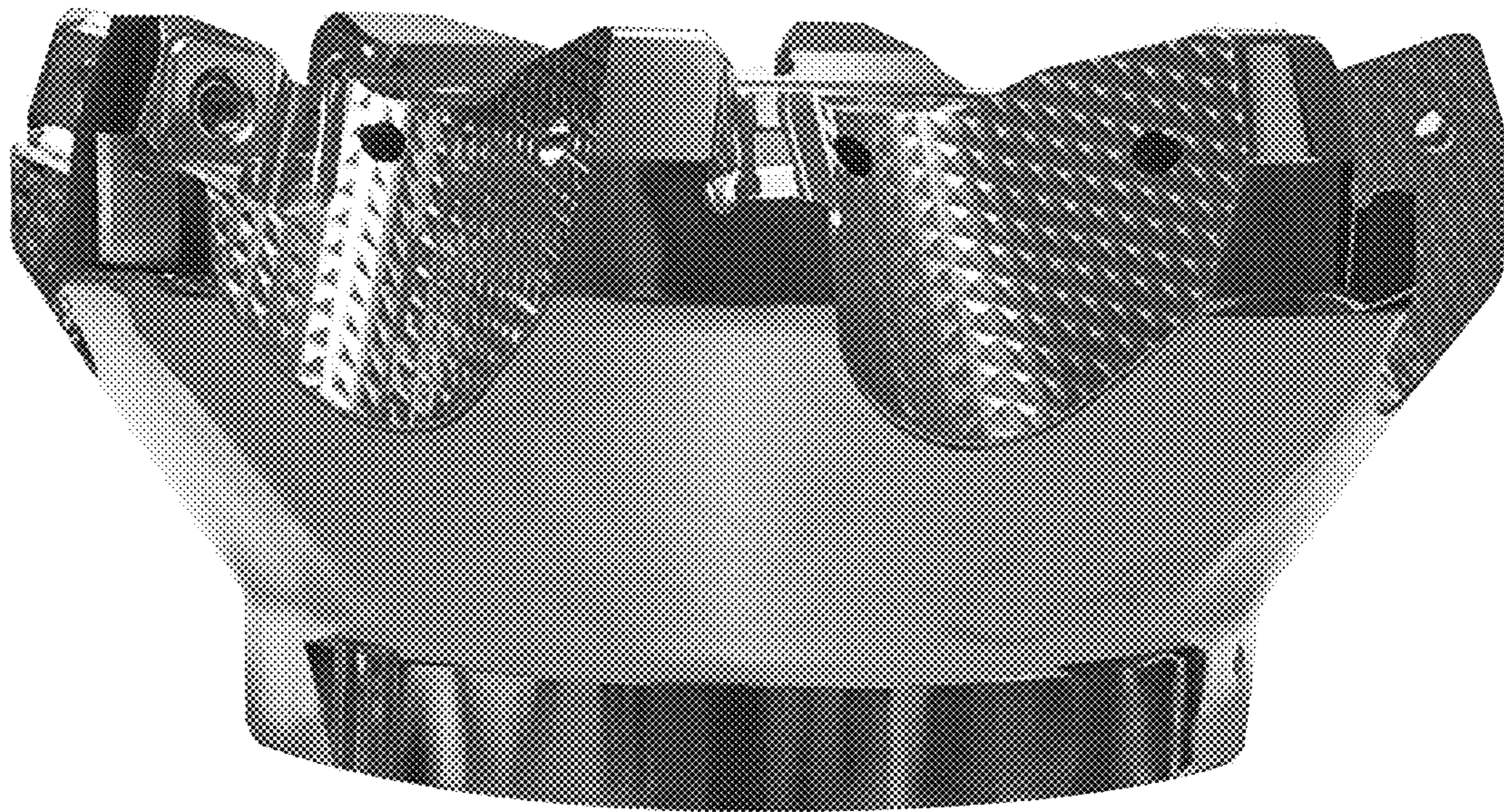

Fig. 3

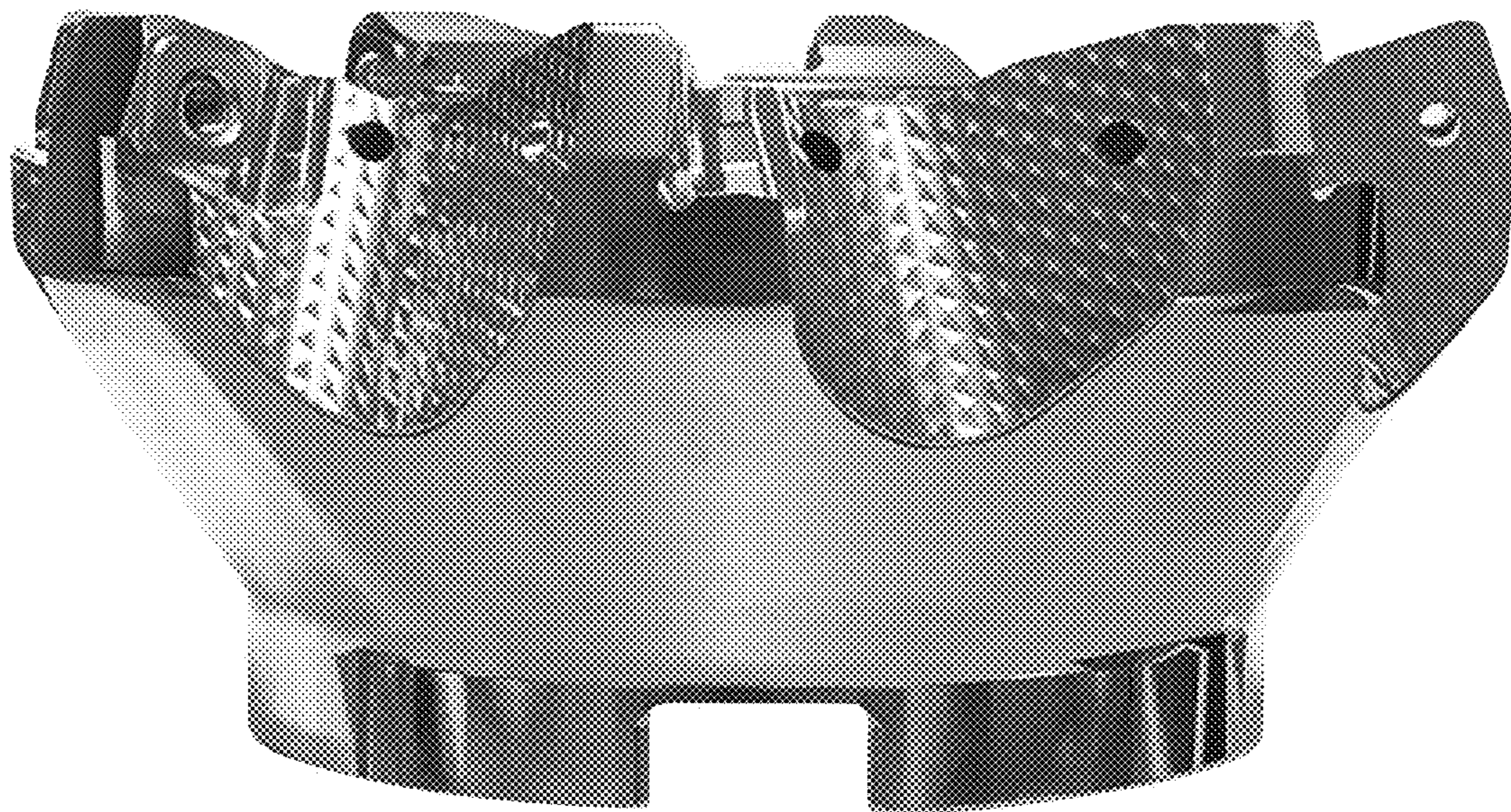

Fig. 4

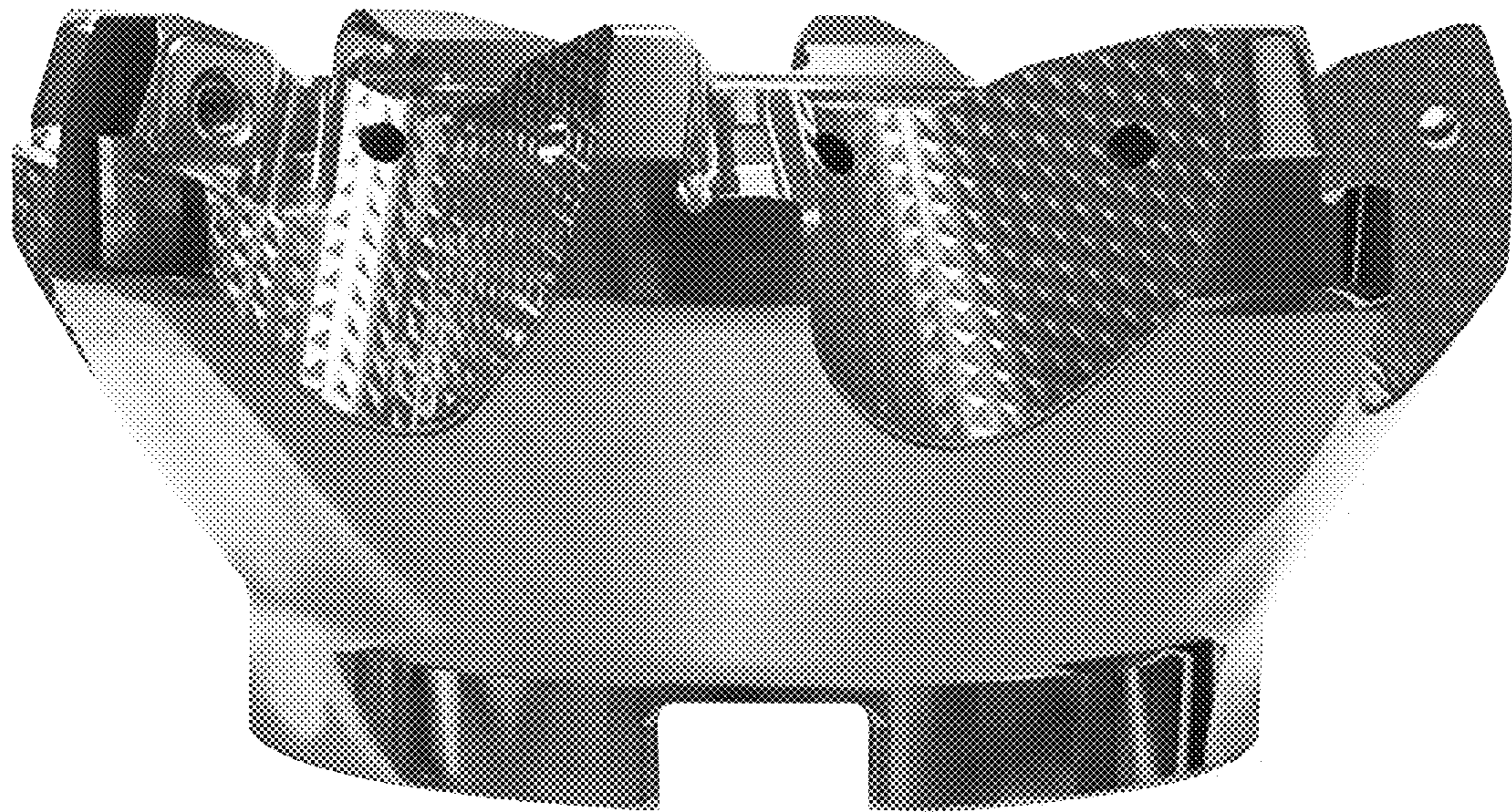

Fig. 5

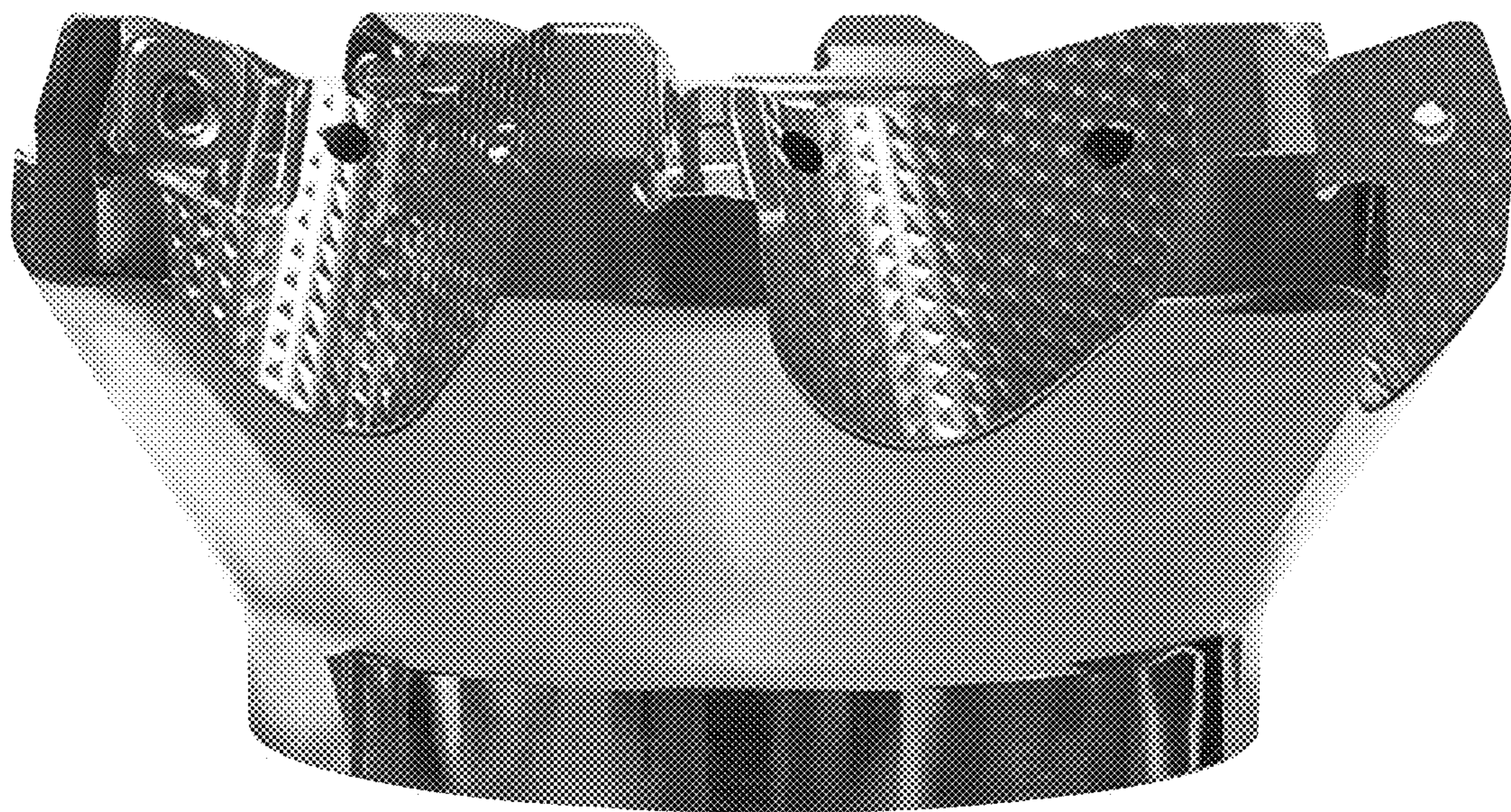

Fig. 6

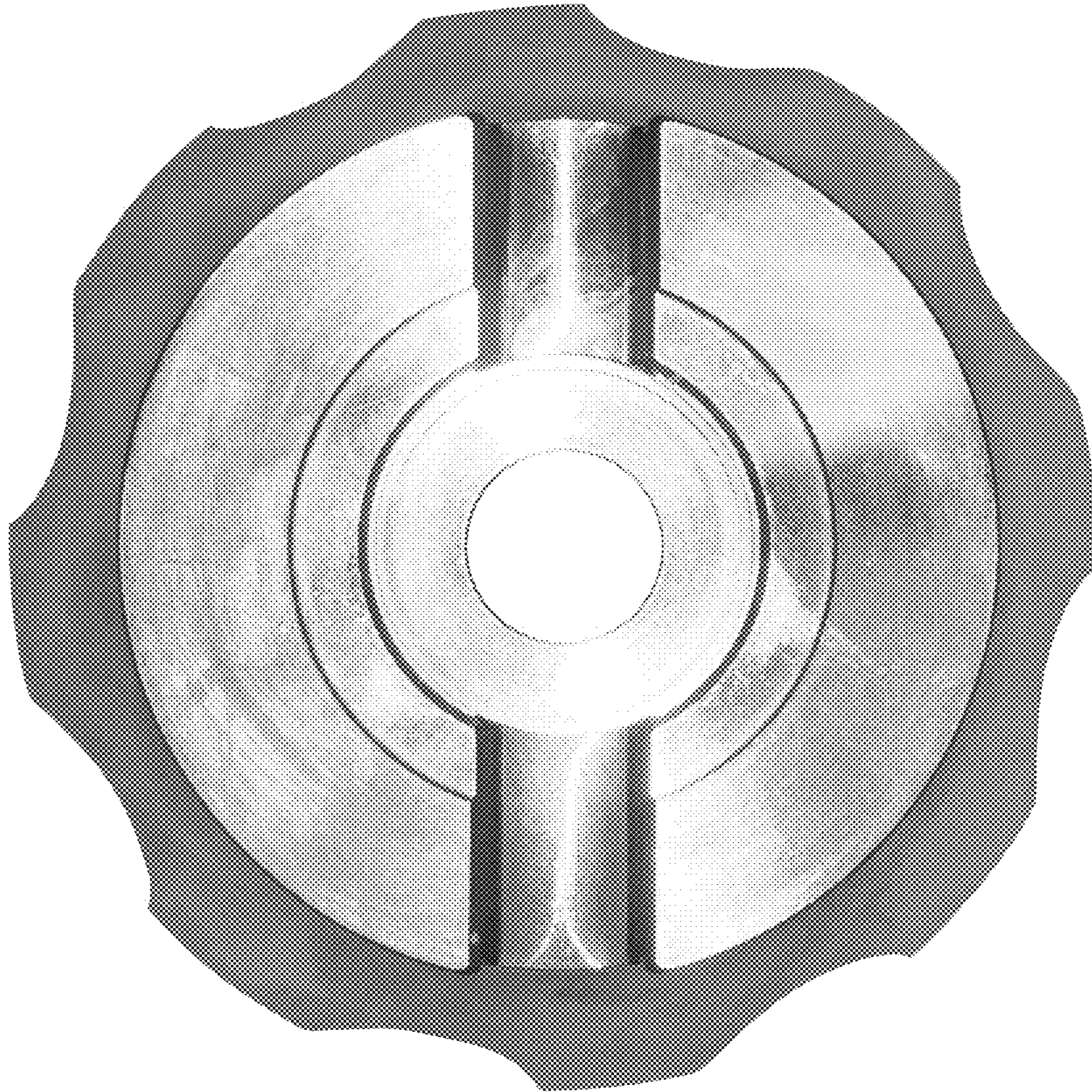

Fig. 7