



US00D953377S

(12) **United States Design Patent**
Park et al.

(10) **Patent No.:** **US D953,377 S**
(45) **Date of Patent:** **** May 31, 2022**

(54) **SEAL FOR DRIVE SHAFT OF A VEHICLE**
(71) Applicant: **ERAE AMS CO., LTD.**, Daegu (KR)
(72) Inventors: **Se Jung Park**, Daegu (KR); **Dal Soo Jang**, Daegu (KR)
(**) Term: **15 Years**
(21) Appl. No.: **35/511,029**
(22) Filed: **Sep. 2, 2020**

D570,375 S * 6/2008 Hideki D15/7
D582,436 S * 12/2008 Shimomura D15/7
D582,437 S * 12/2008 Shimomura D15/7
D582,438 S * 12/2008 Shimomura D15/7
D582,439 S * 12/2008 Shimomura D15/7
D582,440 S * 12/2008 Shimomura D15/7
D582,441 S * 12/2008 Shimomura D15/7
D631,066 S * 1/2011 Itadani D15/9
2018/0194187 A1 * 7/2018 Kashani B60G 3/06

* cited by examiner

Primary Examiner — Richard E Chilcot

(80) **Hague Agreement Data**
Int. Filing Date: **Sep. 2, 2020**
Int. Reg. No.: **DM/211795**
Int. Reg. Date: **Sep. 2, 2020**
Int. Reg. Pub. Date: **Dec. 25, 2020**

(57) **CLAIM**

The ornamental design for a seal for drive shaft of a vehicle, as shown and described.

(30) **Foreign Application Priority Data**

Mar. 9, 2020 (KR) 3020200010399

(51) **LOC (13) Cl.** **15-02**
(52) **U.S. Cl.**
USPC **D15/9**
CPC **B60G 3/06** (2013.01)

(58) **Field of Classification Search**
USPC D15/7-9; D23/231, 232, 225;
417/410.1, 359, 415, 416, 234, 321, 265,
417/405; 277/431, 377, 575, 908, 347
CPC B60G 3/06; B60G 3/18; B60G 15/068
See application file for complete search history.

(56) **References Cited**

U.S. PATENT DOCUMENTS

6,014,915 A * 1/2000 Evans F16H 1/16
74/606 R
D570,374 S * 6/2008 Hideki D15/7

DESCRIPTION

- 1. Seal for drive shaft of a vehicle
- 1.1 : Perspective
- 1.2 : Front
- 1.3 : Back
- 1.4 : Top
- 1.5 : Bottom
- 1.6 : Left
- 1.7 : Right
- 1.8 : FIG. 8 is a longitudinal sectional view.

An object of the design is a seal for a drive shaft of a vehicle that is made of rubber; the seal is inserted into a through hole of a tubular outer shaft of a plunging-type drive shaft that is used in a drive system of a vehicle: the seal prevents grease for a ball spline mechanism for a plunging movement of a drive shaft from being leaked via a through hole of a tubular outer shaft and also prevents air flow via a through hole.

1 Claim, 8 Drawing Sheets

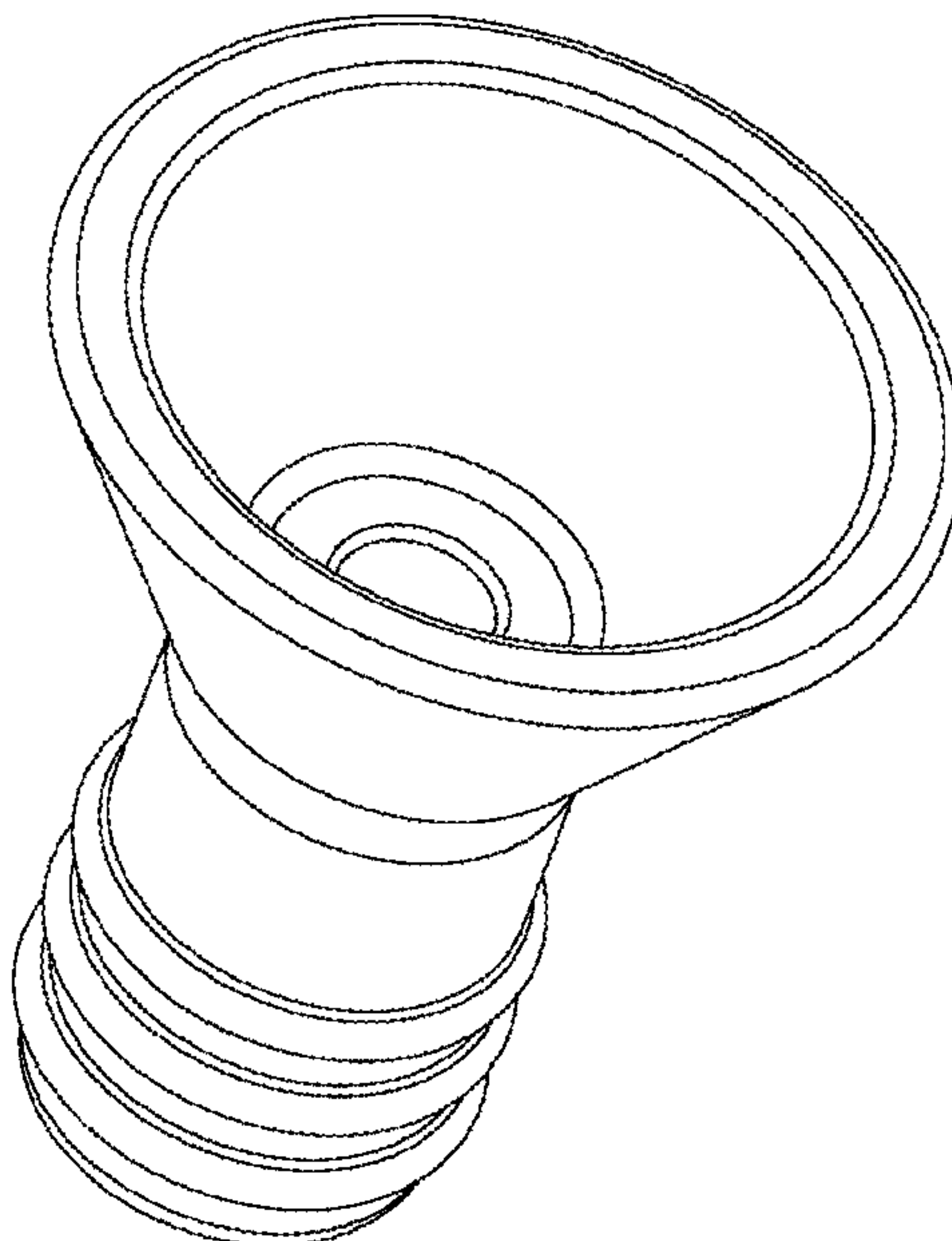

1.1

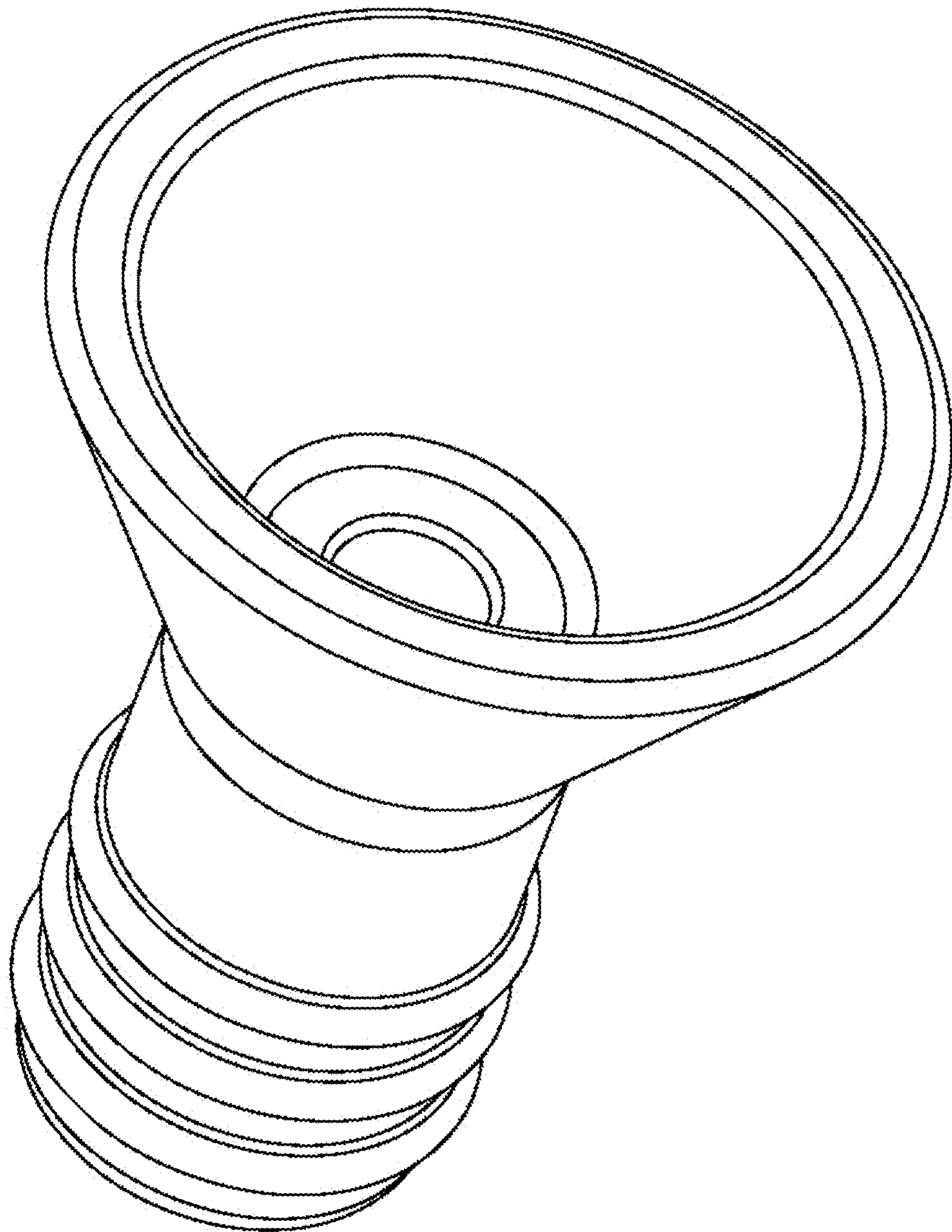

1.2

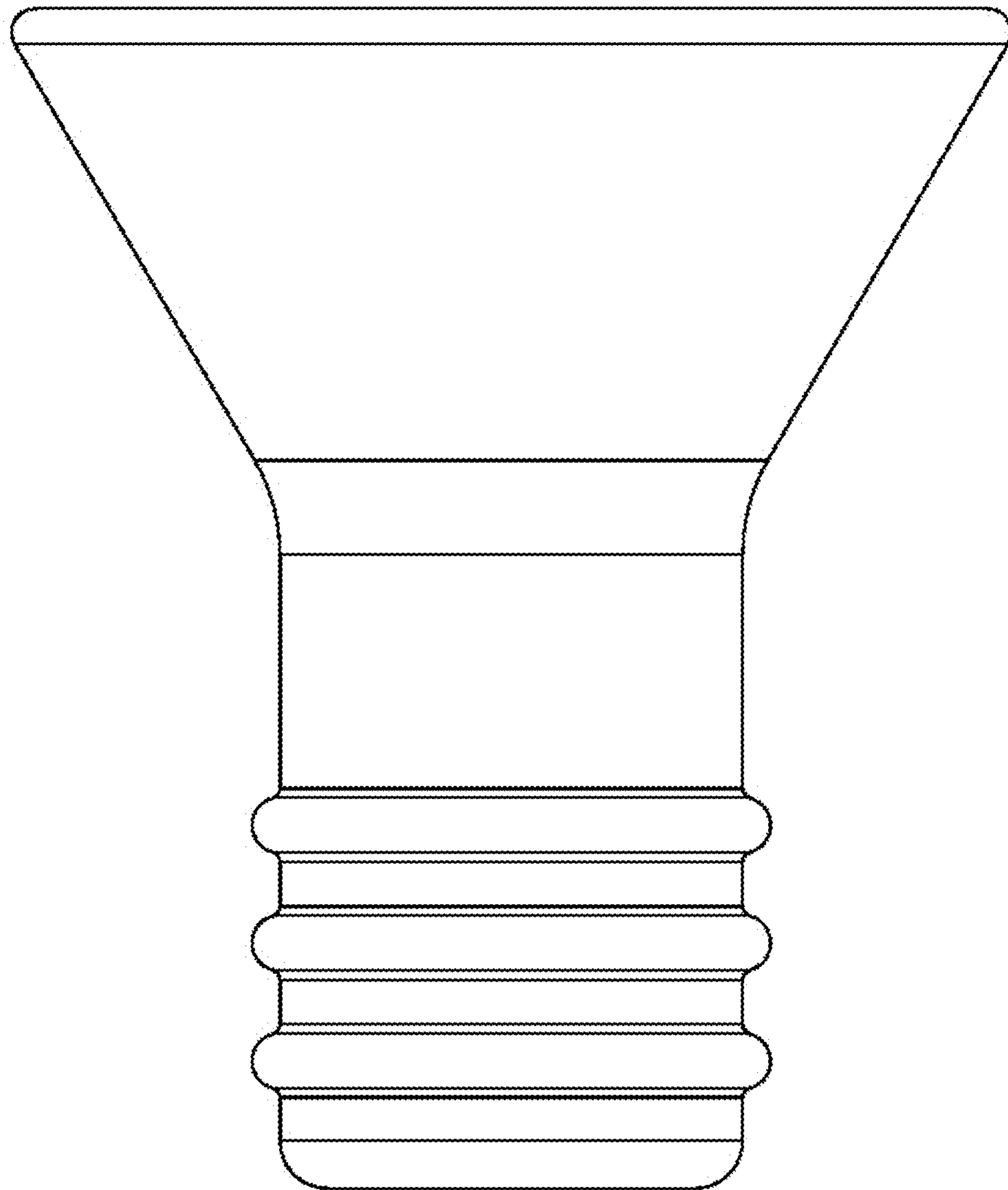

1.3

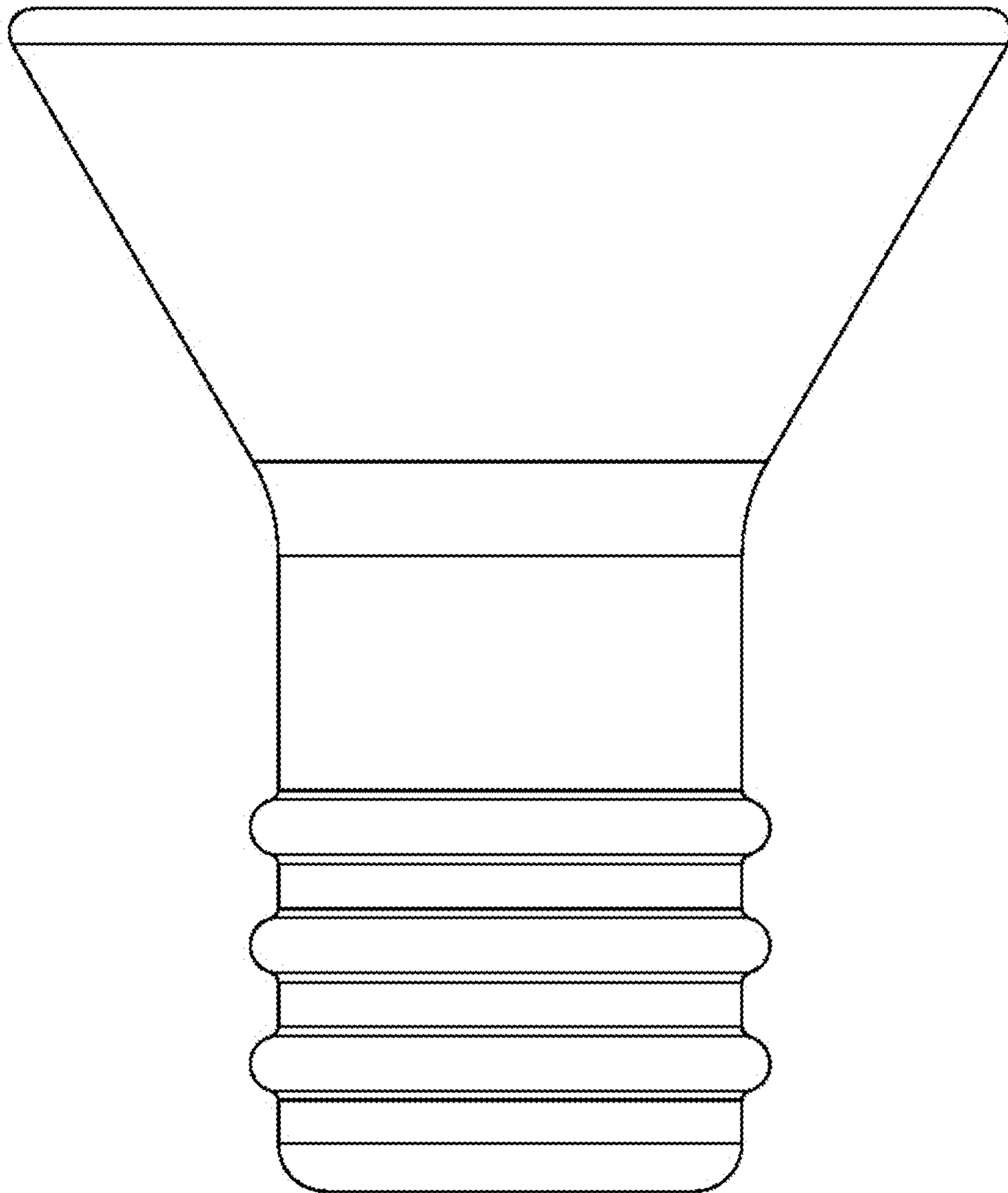

1.4

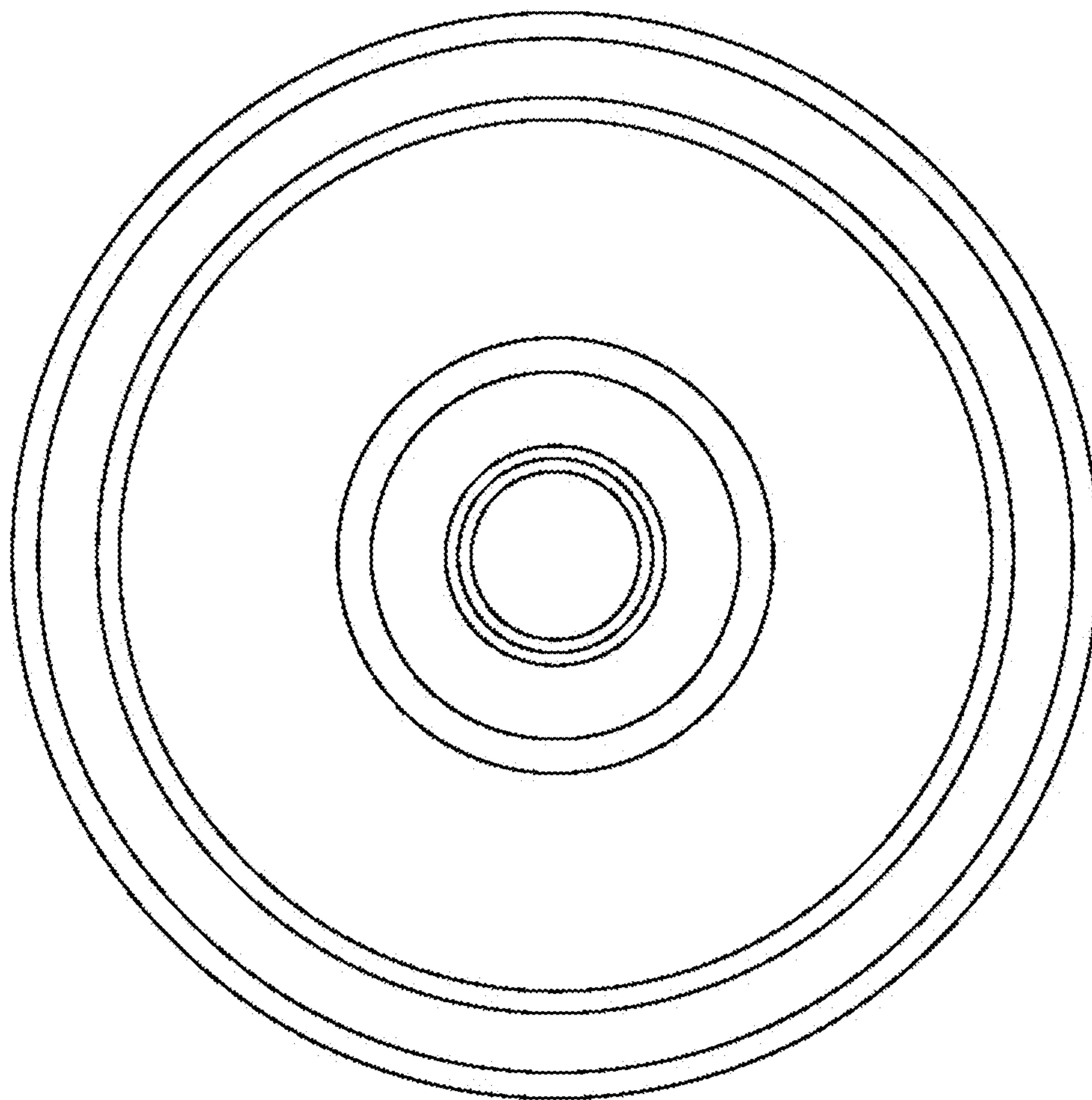

1.5

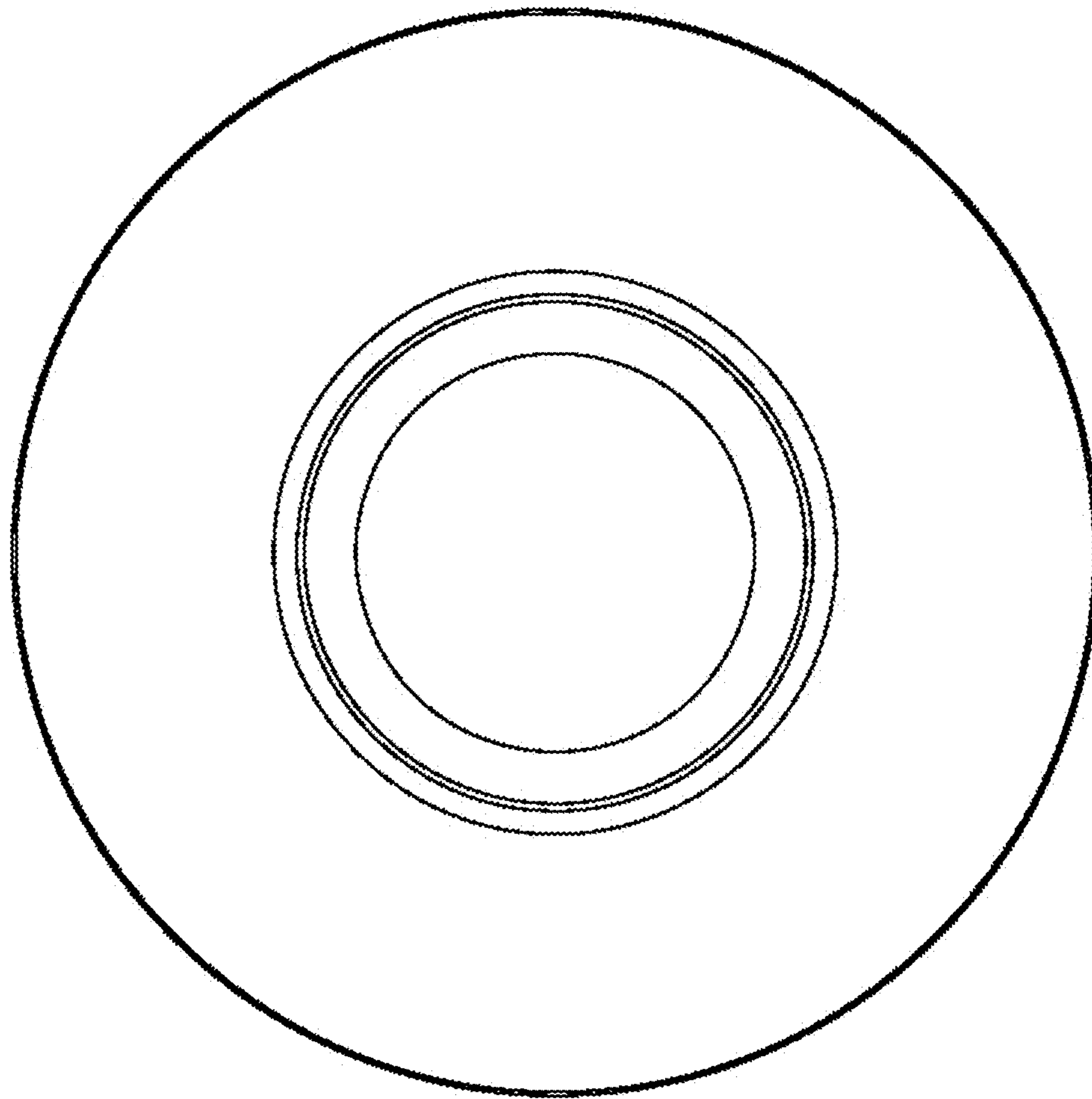

1.6

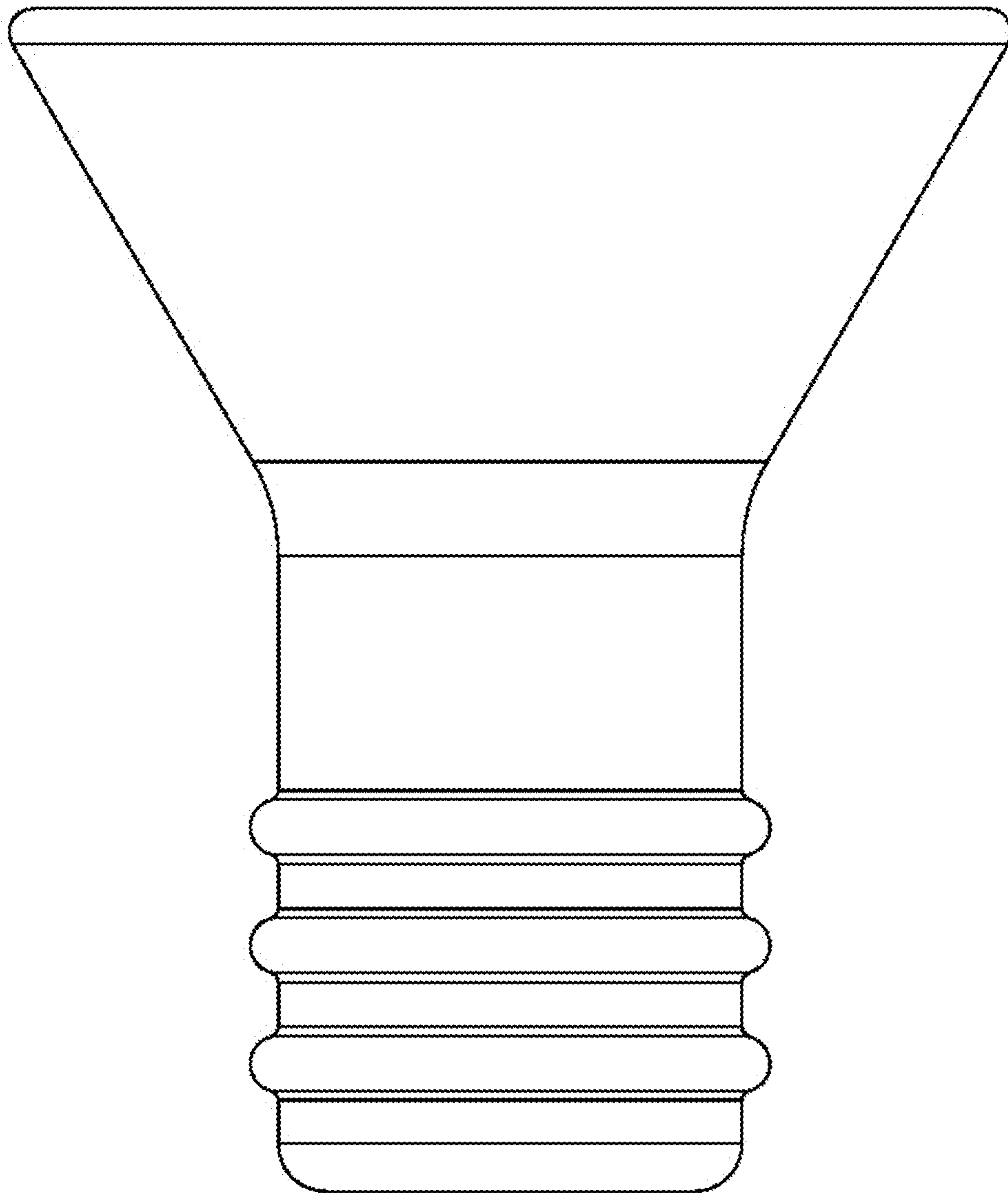

1.7

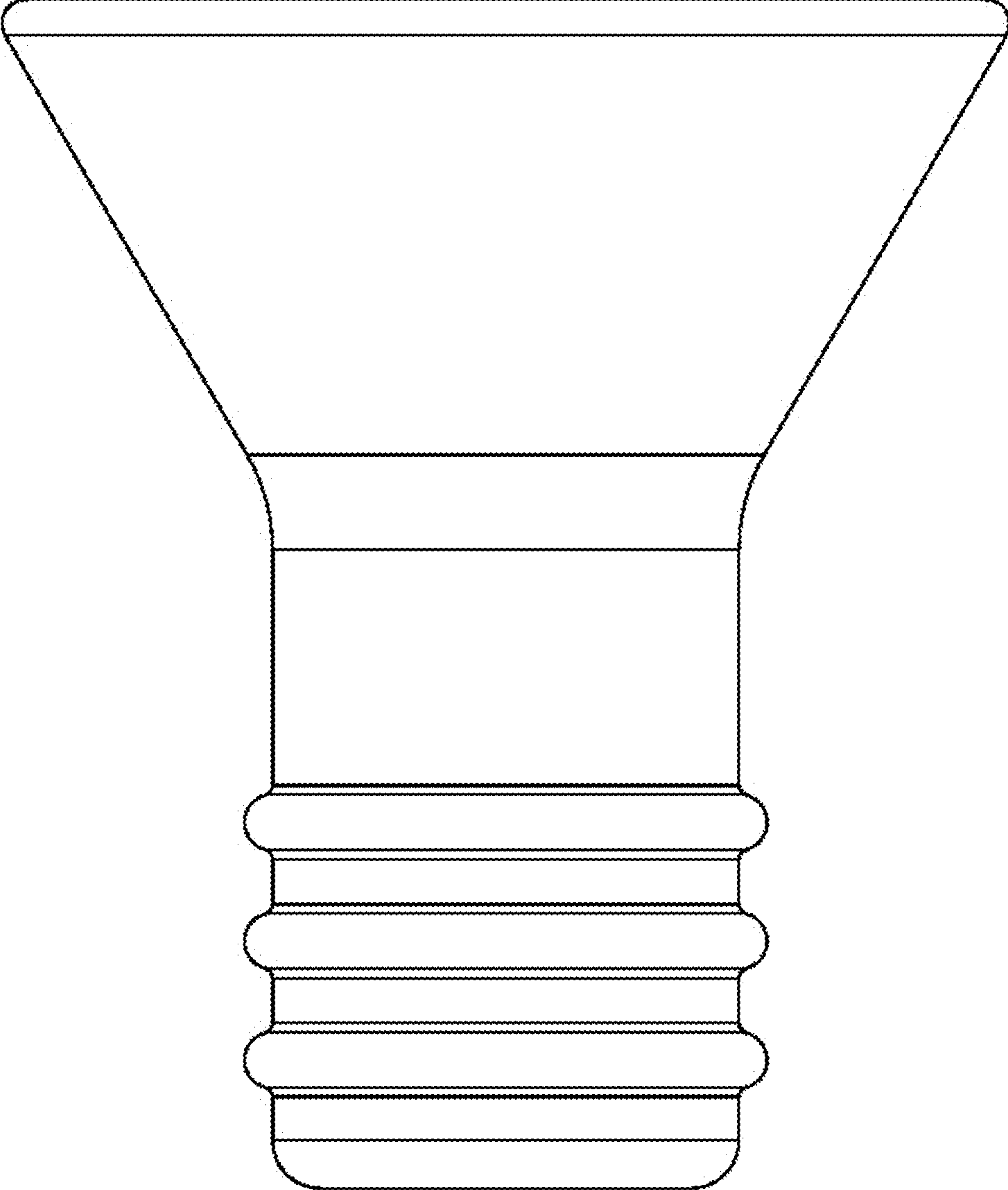

1.8

