



US00D953232S

(12) **United States Design Patent**  
**Echazabal et al.**

(10) **Patent No.:** **US D953,232 S**  
(45) **Date of Patent:** **\*\* May 31, 2022**

(54) **VEHICLE WHEEL**

(71) Applicant: **Toyota Motor North America, Inc.**,  
Plano, TX (US)  
(72) Inventors: **Alberto Echazabal**, Prosper, TX (US);  
**Jakin C. Wilson**, Prosper, TX (US)  
(73) Assignee: **Toyota Motor North America, Inc.**,  
Plano, TX (US)

(\*\*) Term: **15 Years**

(21) Appl. No.: **29/711,627**

(22) Filed: **Nov. 1, 2019**

(51) **LOC (13) Cl.** ..... **12-16**

(52) **U.S. Cl.**  
USPC ..... **D12/209**

(58) **Field of Classification Search**  
USPC ..... D12/204–213; D21/563  
CPC .... B60B 7/00; B60B 7/02; B60B 7/04; B60B  
7/01; B60B 7/06; B60B 3/02; B60B 3/04;  
B60B 3/06; B60B 3/10; B60B 1/00;  
B60B 1/08; B60B 1/10; B60B 1/12  
See application file for complete search history.

(56) **References Cited**

**U.S. PATENT DOCUMENTS**

D461,441 S	*	8/2002	Hartanto	.....	D12/211
D521,920 S	*	5/2006	Phillips	.....	D12/209
D527,335 S	*	8/2006	Kim	.....	D12/211
D534,473 S	*	1/2007	Bernoni	.....	D12/211
D537,767 S	*	3/2007	Pfeiffer	.....	D12/211

D652,363 S	*	1/2012	Chung	.....	D12/211
D654,420 S	*	2/2012	Guay	.....	D12/211
D695,183 S	*	12/2013	Chung	.....	D12/209
D741,238 S	*	10/2015	Chung	.....	D12/209
D753,573 S	*	4/2016	Watkin	.....	D12/211
D775,049 S	*	12/2016	Scheer	.....	D12/211
D800,046 S	*	10/2017	Chung	.....	D12/211
D803,751 S	*	11/2017	Chung	.....	D12/209
D806,631 S	*	1/2018	Sempek	.....	D12/211
D817,841 S	*	5/2018	Chung	.....	D12/209
D849,658 S	*	5/2019	Licklitter	.....	D12/211
D866,442 S	*	11/2019	Celik	.....	D12/211
D868,664 S	*	12/2019	Dewitt	.....	D12/211
D883,175 S	*	5/2020	Metros	.....	D12/211
D885,293 S	*	5/2020	Gallert	.....	D12/211

\* cited by examiner

*Primary Examiner* — Stacia A Cadmus

(74) *Attorney, Agent, or Firm* — Dinsmore & Shohl LLP

(57) **CLAIM**

The ornamental design for a vehicle wheel, as shown and described.

**DESCRIPTION**

FIG. 1 is a front perspective view of a vehicle wheel showing our new design;  
FIG. 2 is a rear perspective view thereof;  
FIG. 3 is a front view thereof;  
FIG. 4 is a rear view thereof; and,  
FIG. 5 is a side view thereof.  
In the drawings, the broken lines depict portions of the wheel that form no part of the claimed design.

**1 Claim, 5 Drawing Sheets**

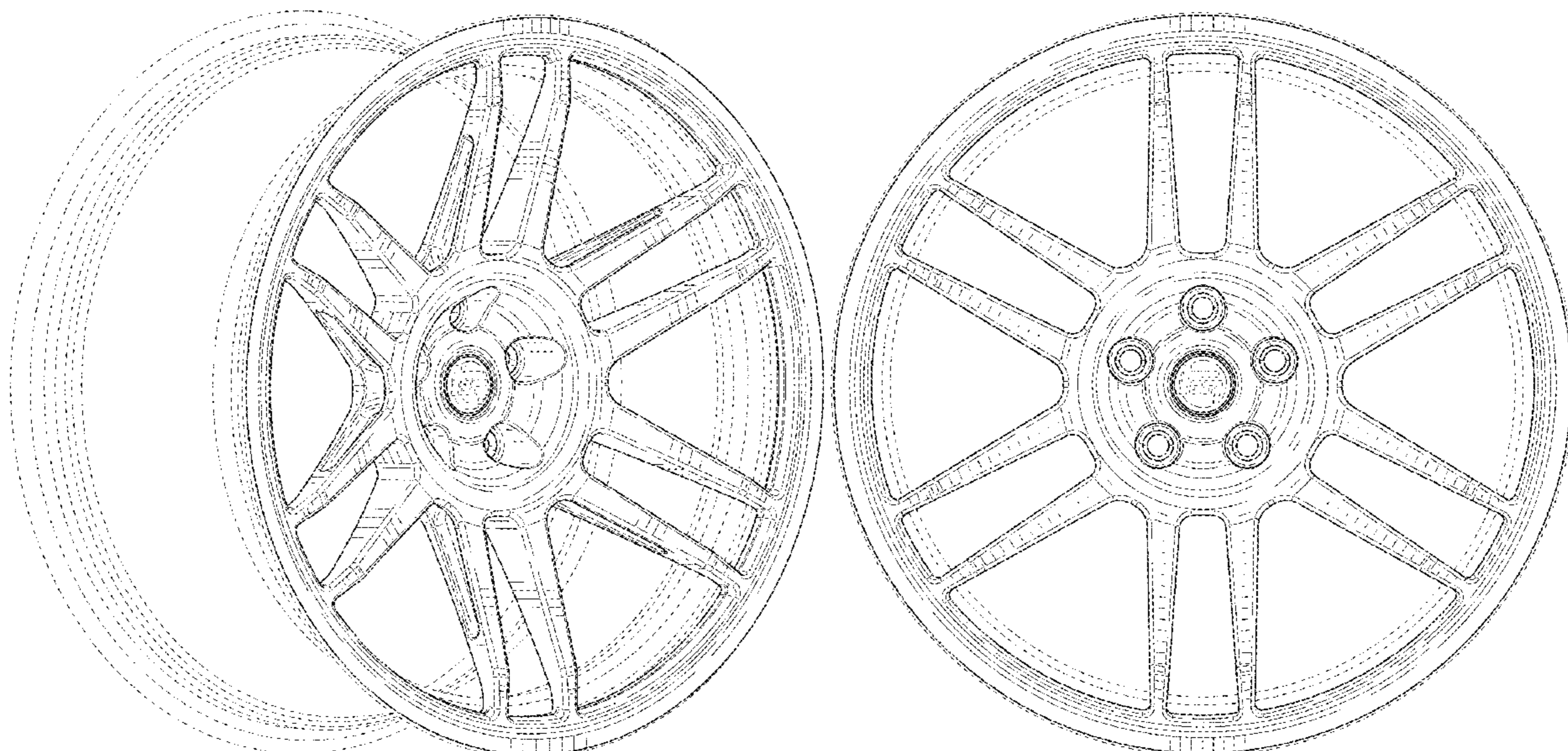



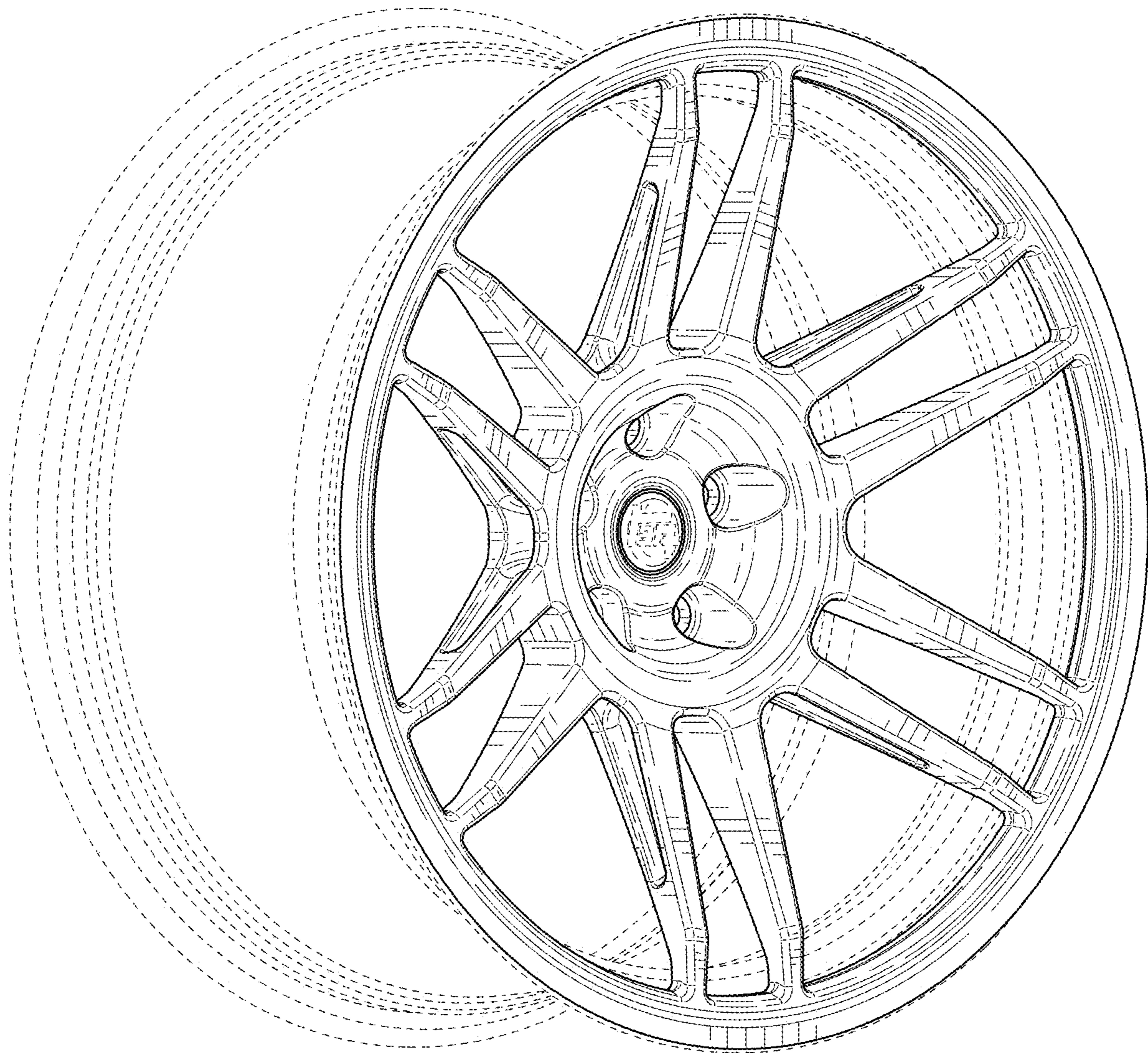

FIG. 1

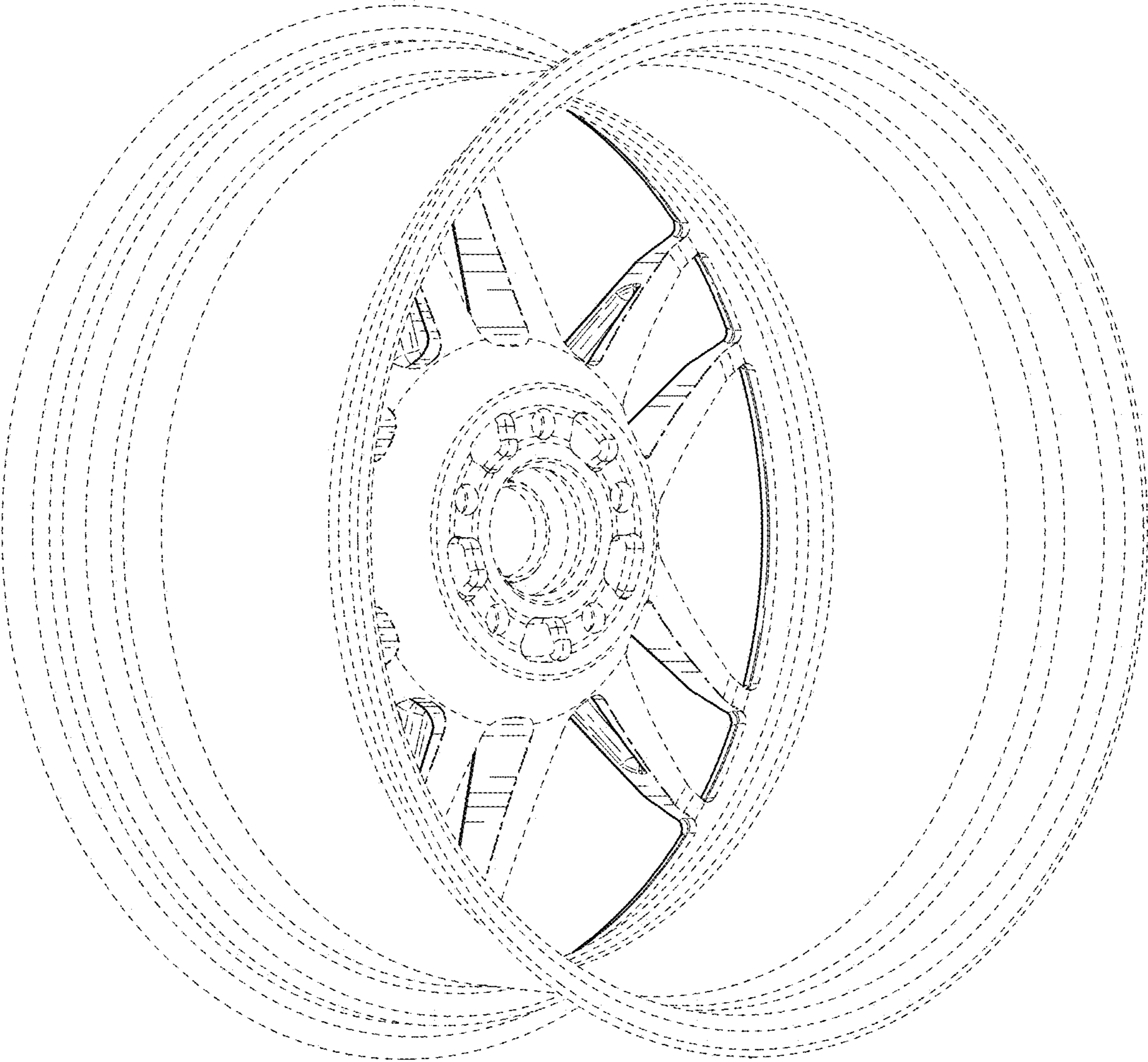

FIG. 2



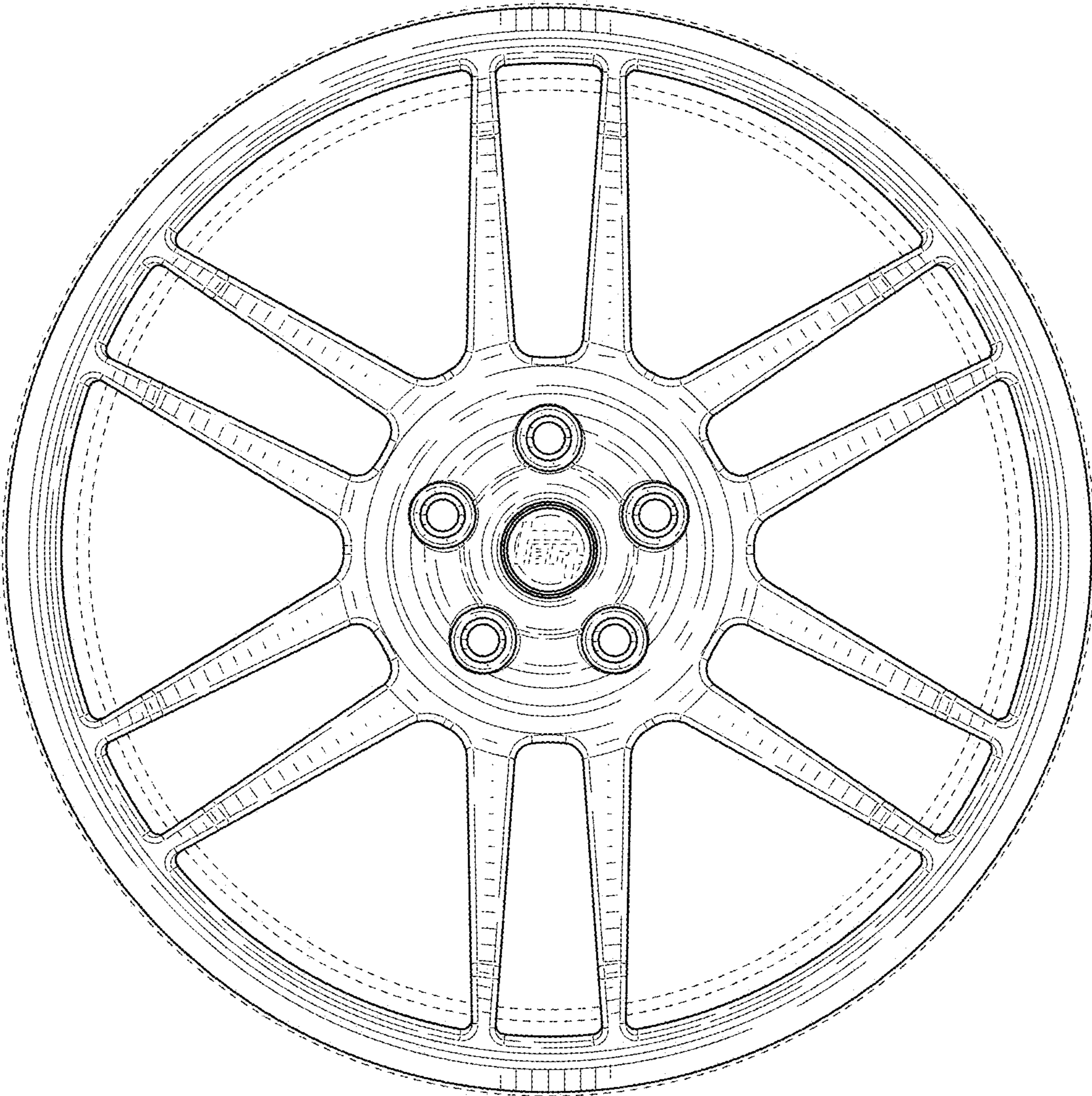

FIG. 3

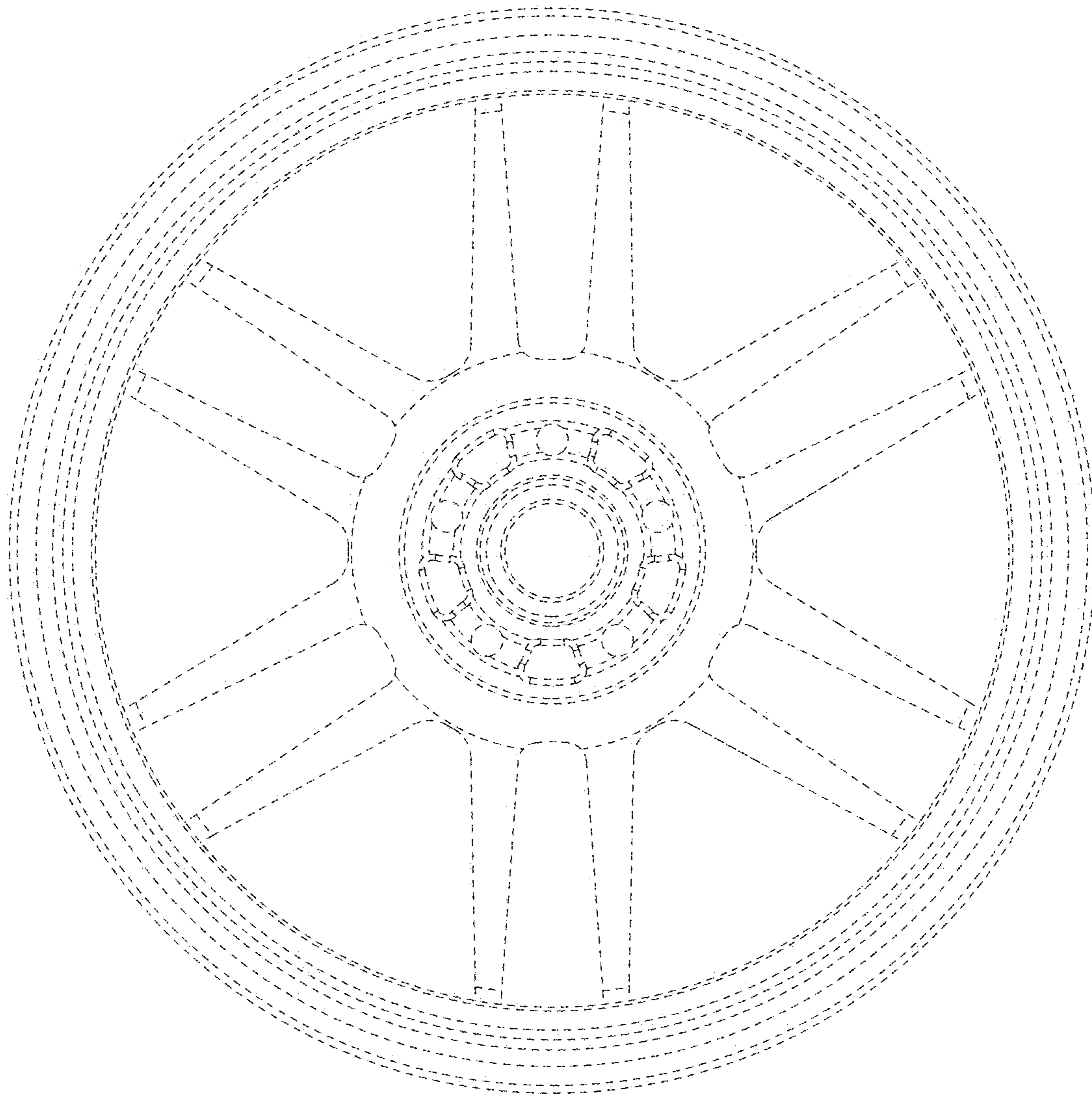

FIG. 4

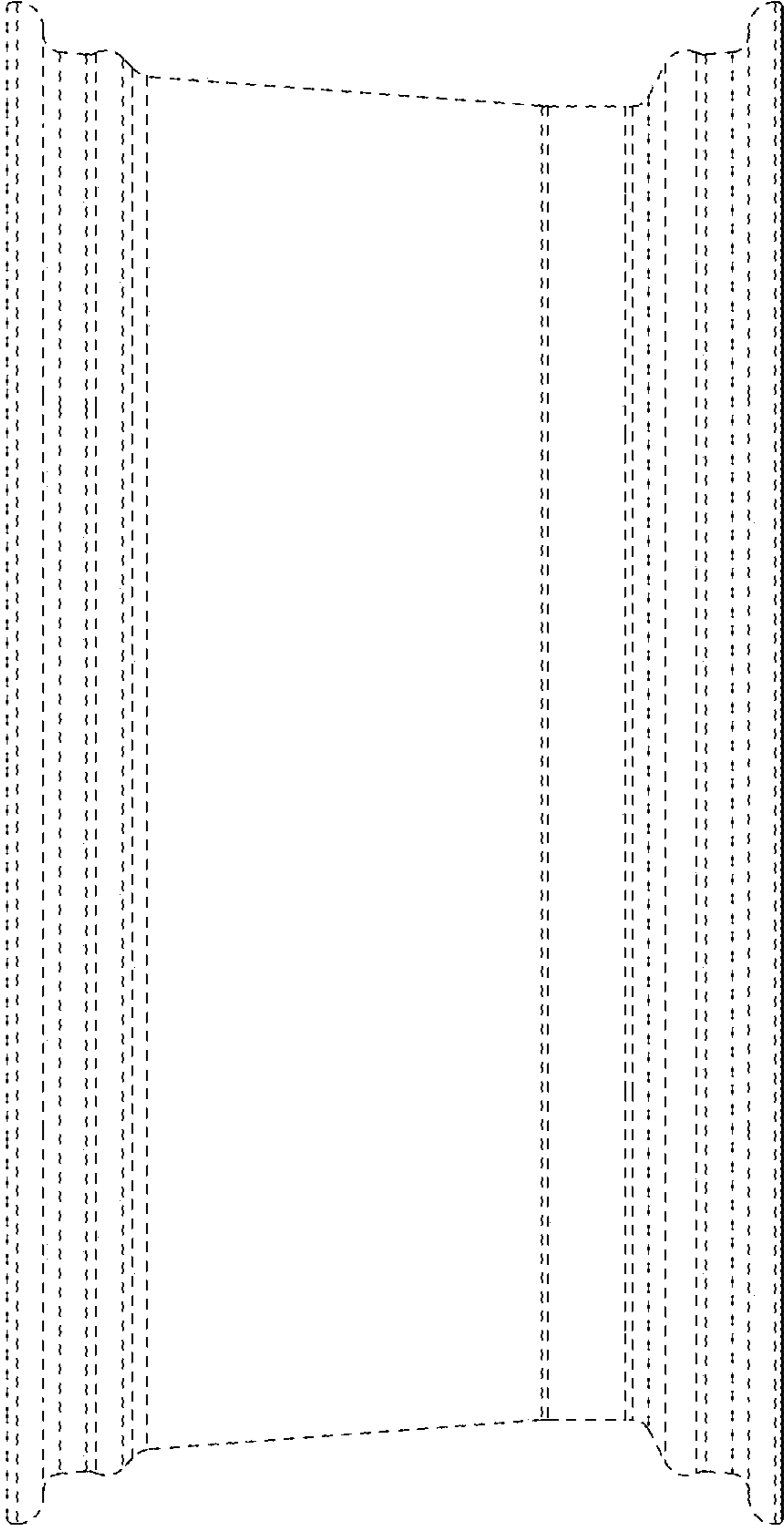

FIG. 5