



US00D953224S

(12) **United States Design Patent** (10) **Patent No.:** **US D953,224 S**  
**Li** (45) **Date of Patent:** **\*\* May 31, 2022**

- (54) **RV WINDOW SHADE**
- (71) Applicant: **Guangzhou Boju Information Technology Co., Ltd.**, Guangzhou (CN)
- (72) Inventor: **Longlong Li**, Guangzhou (CN)
- (73) Assignee: **Guangzhou Boju Information Technology Co., Ltd.**, Guangzhou (CN)
- (\*\*) Term: **15 Years**
- (21) Appl. No.: **29/779,228**
- (22) Filed: **Apr. 16, 2021**
- (51) **LOC (13) Cl.** ..... **12-16**
- (52) **U.S. Cl.**  
USPC ..... **D12/183**
- (58) **Field of Classification Search**  
USPC ..... D12/183, 182, 190, 191, 401, 404  
CPC ..... B60J 3/0204; B60J 1/2002; B60J 1/2005;  
B60J 1/20; B60J 3/0208; B60J 3/02  
See application file for complete search history.

D895,494 S *	9/2020	BerTrand	.....	D12/183
D910,515 S *	2/2021	Patel	.....	D12/183
D922,282 S *	6/2021	Catuzza	.....	D12/183
D940,022 S *	1/2022	Duggan	.....	D12/183
D940,023 S *	1/2022	Duggan	.....	D12/183
D940,024 S *	1/2022	Duggan	.....	D12/183
D941,202 S *	1/2022	Nash	.....	D12/183

\* cited by examiner

*Primary Examiner* — Katrina A Betton

(74) *Attorney, Agent, or Firm* — Zhihua Han; Wen IP LLC

(57) **CLAIM**

The ornamental design for a RV window shade, as shown and described.

**DESCRIPTION**

FIG. 1 is a perspective view of a RV window shade, showing my new design;  
 FIG. 2 is a front elevation view thereof, the rear elevation view being the same;  
 FIG. 3 is a left side elevation view thereof, the right side elevation view being the same;  
 FIG. 4 is a top plan view thereof, the bottom plan view being the same; and,  
 FIG. 5 is another perspective view thereof, for clarity of illustration.

The dash-dot broken lines in the drawings depict environment only and form no part of the claimed design. The dash-dash broken lines disclose stitching which forms part of the claimed design.

**1 Claim, 5 Drawing Sheets**

(56) **References Cited**

U.S. PATENT DOCUMENTS

D710,774 S	8/2014	Eskandry	
D721,628 S	1/2015	Eskandry	
D757,618 S	5/2016	Richardson	
D793,308 S *	8/2017	Lewis	..... D12/183
D801,244 S *	10/2017	Shu	..... D12/183
D828,253 S *	9/2018	Mao	..... D12/183
D879,689 S *	3/2020	Holt	..... D12/183
D886,696 S *	6/2020	Holt	..... D12/183

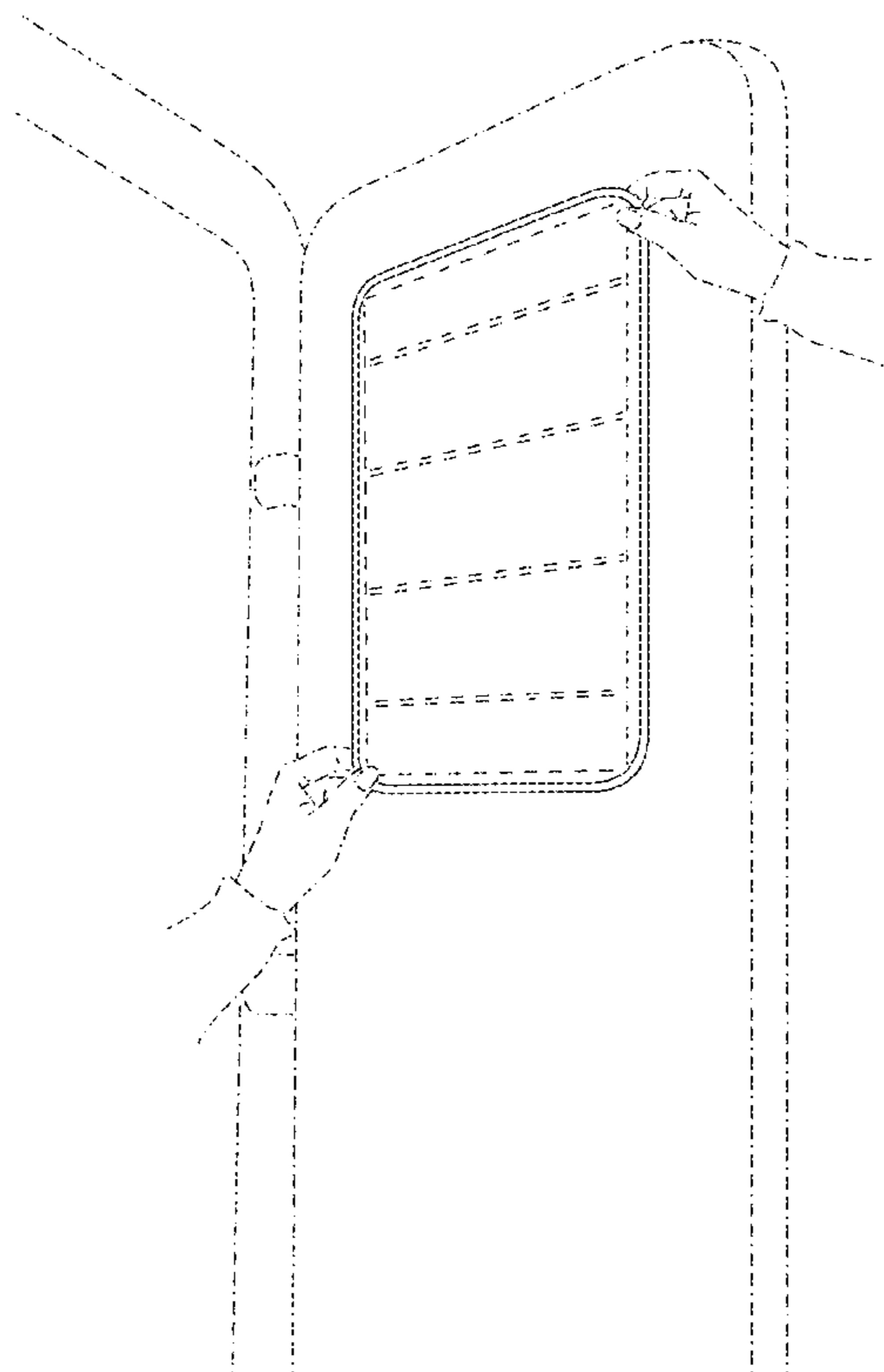

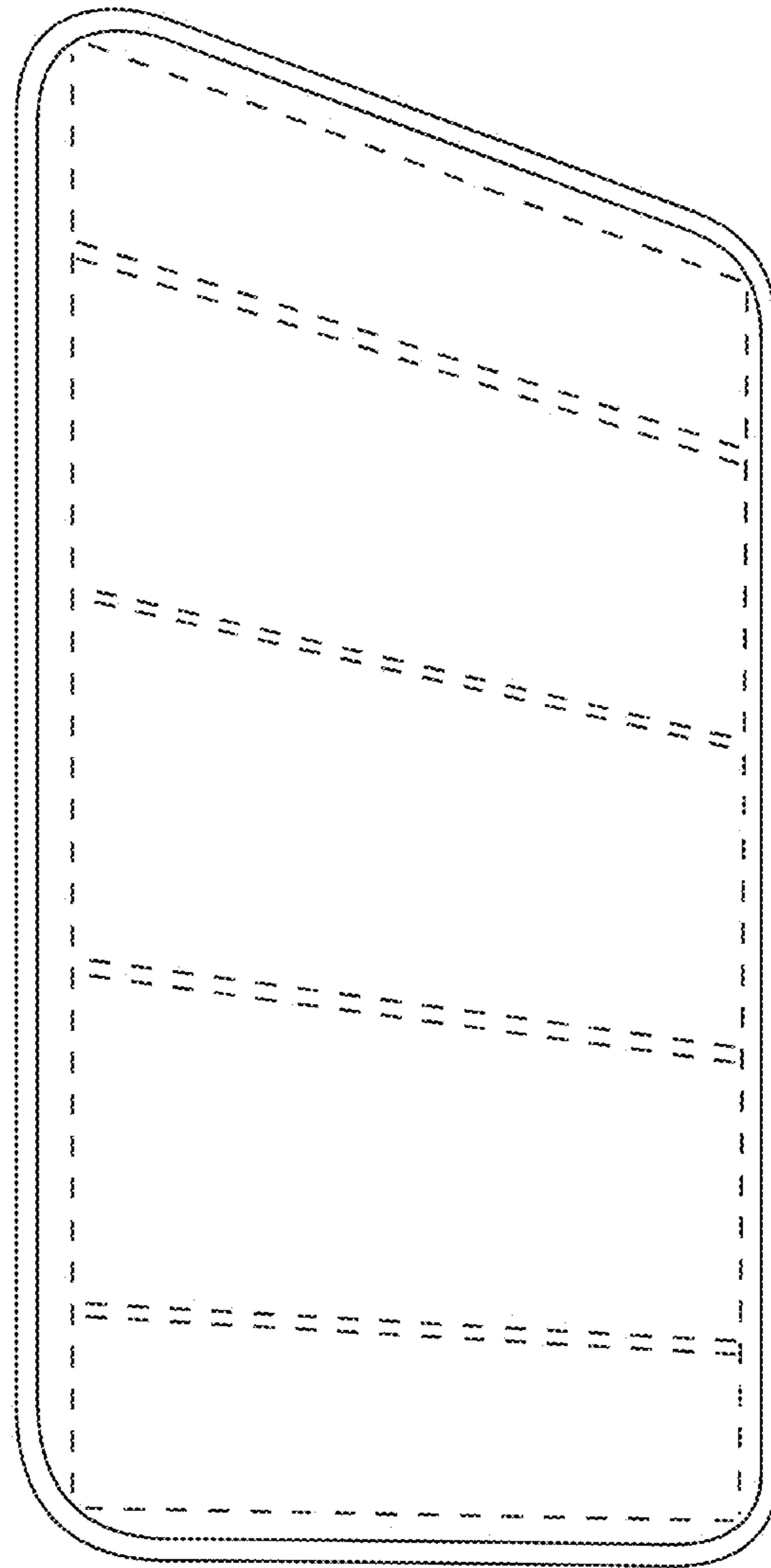

FIG. 1

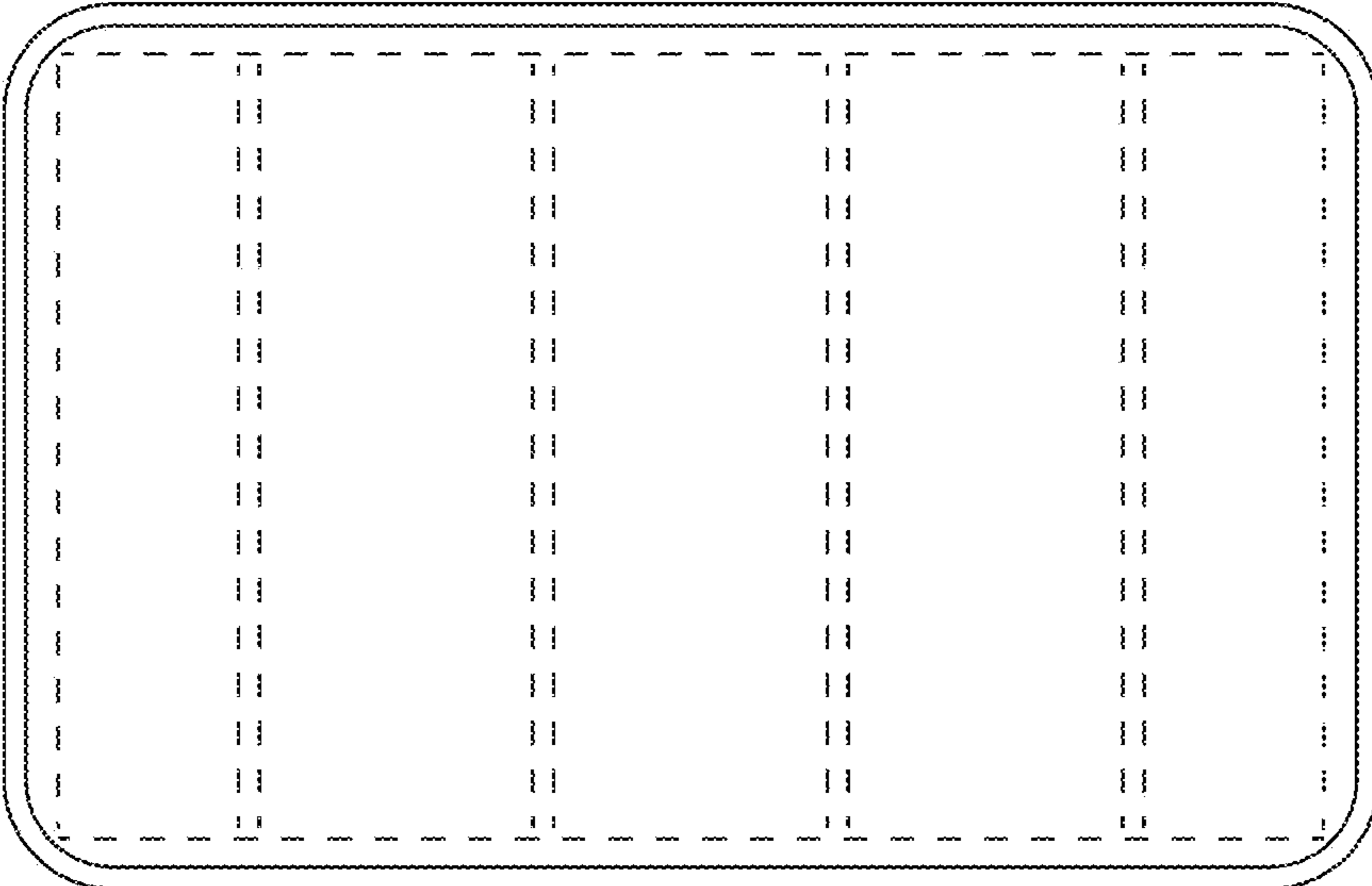

FIG. 2



FIG. 3



**FIG. 4**

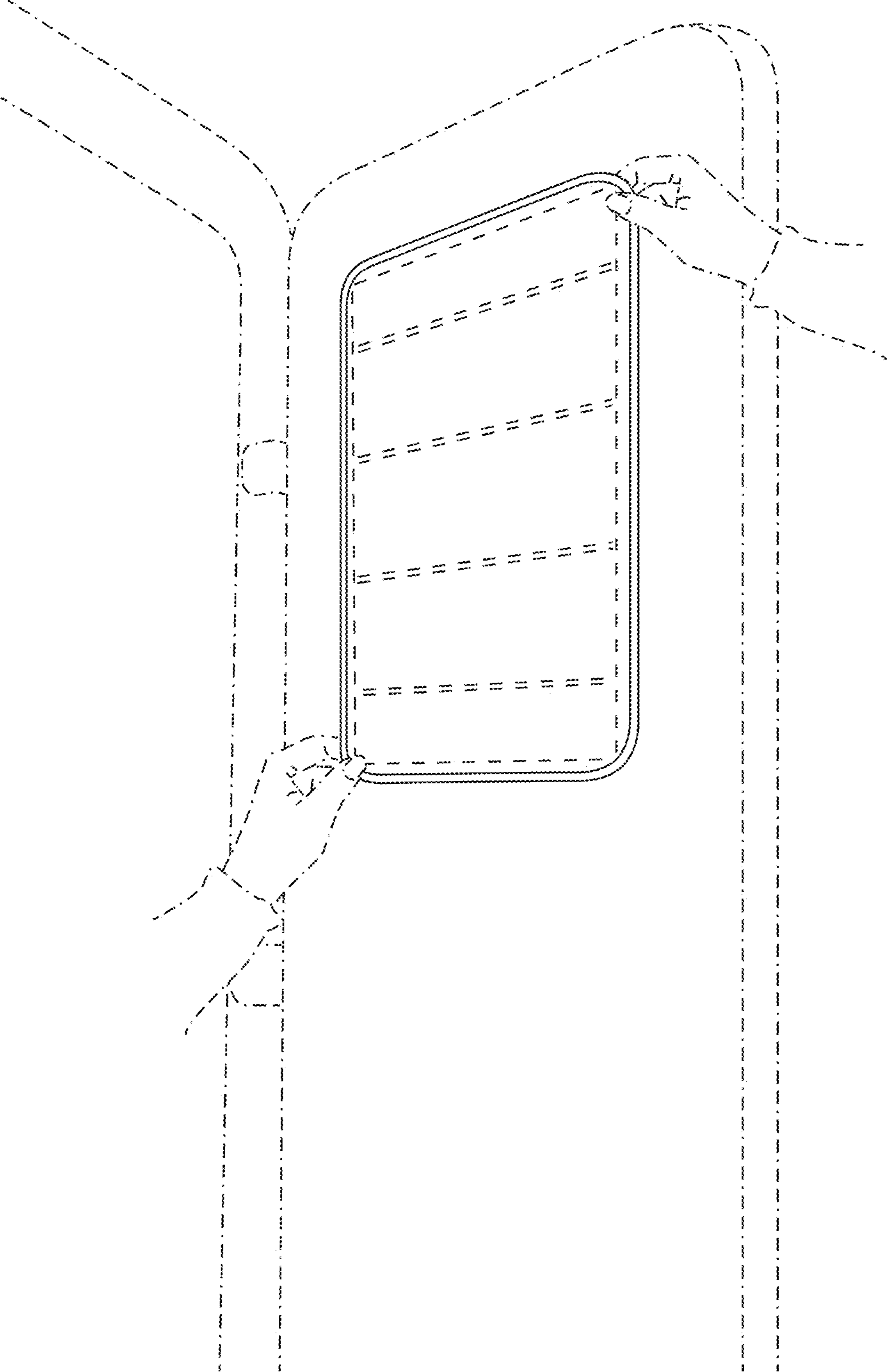

FIG. 5