



US00D952403S

(12) **United States Design Patent** (10) **Patent No.:** **US D952,403 S**  
**Fan** (45) **Date of Patent:** **\*\* May 24, 2022**

(54) **BAMBOO TURNTABLE**  
(71) Applicant: **HONG KONG BESTIME GROUP COMPANY LIMITED**, North Point (CN)  
(72) Inventor: **Zhenrong Fan**, North Point (CN)  
(\*\*) Term: **15 Years**  
(21) Appl. No.: **29/797,999**  
(22) Filed: **Jul. 5, 2021**  
(51) **LOC (13) Cl.** ..... **07-01**  
(52) **U.S. Cl.**  
USPC ..... **D7/501**  
(58) **Field of Classification Search**  
USPC ..... D7/501, 500, 553.6, 554.1, 590, 600.2; 211/74, 133.4, 131.1; D6/691, 349, 685, D6/406.6; 40/377  
CPC ..... A47J 47/16; A47B 49/004  
See application file for complete search history.

D370,142 S \* 5/1996 Konecny ..... D6/692.6  
7,287,870 B1 \* 10/2007 Knoch ..... A47G 19/00 362/97.1  
D624,360 S \* 9/2010 Leavelle ..... D7/553.6  
D648,165 S \* 11/2011 Michnuk ..... D6/534  
D679,544 S \* 4/2013 Goodman ..... D7/501  
D743,708 S \* 11/2015 Cohen ..... D6/349  
D745,785 S \* 12/2015 Cohen ..... D6/349  
D749,863 S \* 2/2016 Cohen ..... D6/349  
D761,621 S \* 7/2016 Hsu et al.  
D786,593 S \* 5/2017 Almaghlouth ..... D6/692.4  
D806,474 S \* 1/2018 Greenwood  
10,130,199 B2 \* 11/2018 Deszcz ..... A21C 15/00  
D834,891 S \* 12/2018 Greenwood  
D839,671 S \* 2/2019 Greenwood ..... D7/501  
D864,045 S \* 10/2019 Weiss ..... D12/130  
D868,511 S \* 12/2019 McBride  
D883,720 S \* 5/2020 Johnson ..... D6/677.1  
D889,210 S \* 7/2020 Jones ..... D7/610  
D893,189 S \* 8/2020 Hu ..... D3/307  
D910,348 S \* 2/2021 Snell

(Continued)

Primary Examiner — Cynthia R Underwood  
(74) Attorney, Agent, or Firm — Rumit Ranjit Kanakia

(56) **References Cited**

**U.S. PATENT DOCUMENTS**

D89,946 S \* 5/1933 Brown ..... D6/692.4  
D134,392 S \* 11/1942 Waltman ..... D6/692  
2,620,089 A \* 12/1952 Van Loghem ..... A47J 36/34 220/574  
2,780,081 A \* 2/1957 Alexander ..... A47J 31/44 D7/619.1  
D204,198 S \* 3/1966 Lippisch ..... D7/701  
D247,557 S \* 3/1978 Hemmy ..... D6/677.1  
D249,855 S \* 10/1978 Levell ..... D6/692  
D254,428 S \* 3/1980 Lasowski ..... D6/692  
D259,230 S \* 5/1981 Snyder ..... D7/590  
D279,300 S \* 6/1985 Wolf ..... D21/408  
D301,422 S \* 6/1989 Schmidt ..... D32/54  
D304,789 S \* 11/1989 Scholl ..... D6/692.6  
D309,539 S \* 7/1990 Lewis ..... D6/692.6  
D362,787 S \* 10/1995 Burke ..... D7/505

(57) **CLAIM**

I claim the ornamental design for a bamboo turntable, as shown and described.

**DESCRIPTION**

FIG. 1 is a Perspective view of a bamboo turntable showing my new design;  
FIG. 2 is a Front view thereof;  
FIG. 3 is a Back view thereof;  
FIG. 4 is a Left-side view thereof;  
FIG. 5 is a Right-side view thereof;  
FIG. 6 is a Top view thereof; and,  
FIG. 7 is a Bottom view thereof.  
The broken lines in the drawings depict portions of the bamboo turntable that form no part of the claimed design.

**1 Claim, 7 Drawing Sheets**

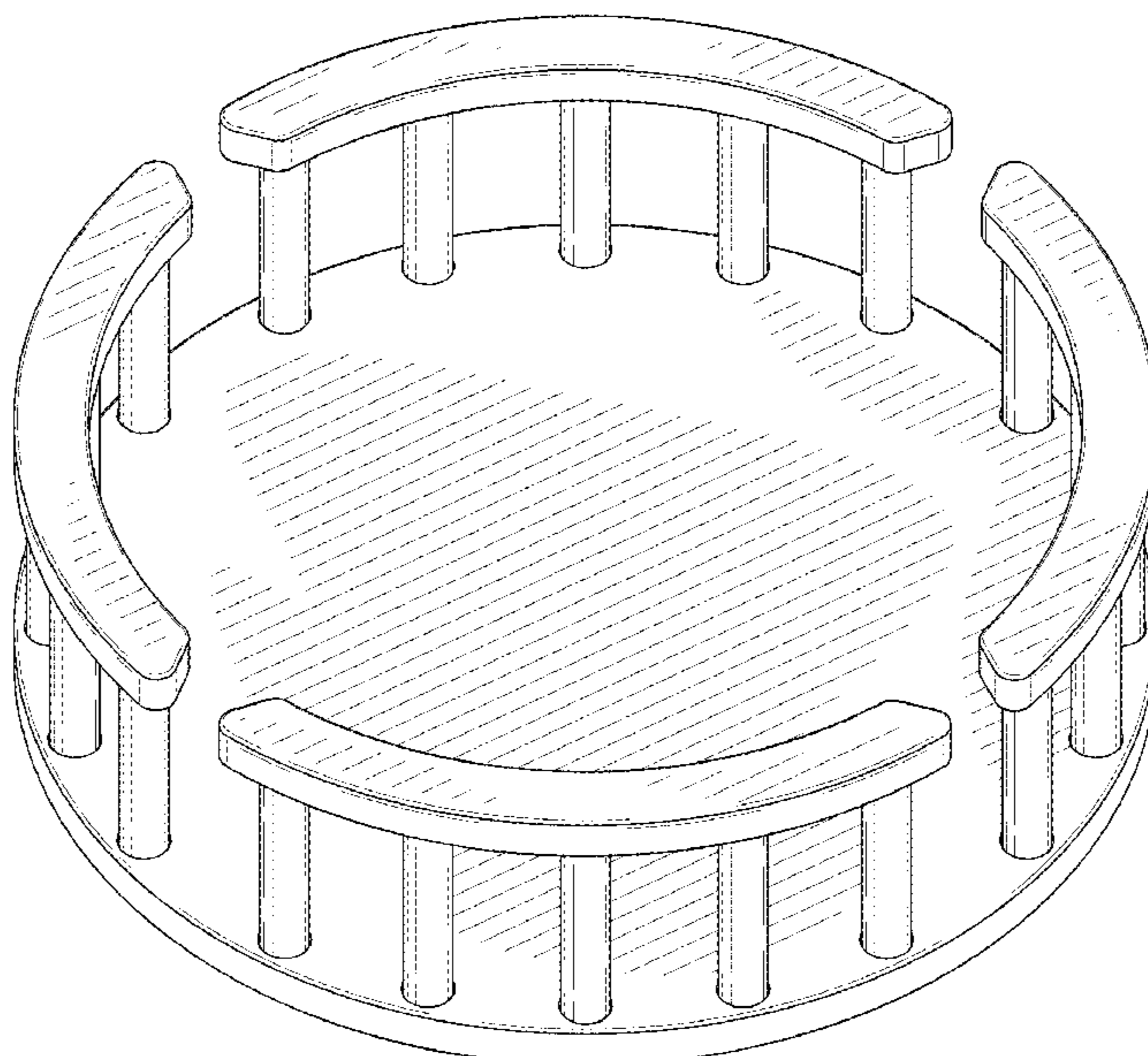

(56)

**References Cited**

U.S. PATENT DOCUMENTS

D916,186 S *	4/2021	Spiring .....	D19/64
2008/0134551 A1 *	6/2008	Conforti .....	G09F 11/02
			108/27
2009/0057249 A1 *	3/2009	Donnellan .....	A47F 7/0028
			211/77
2016/0045039 A1 *	2/2016	McGregor .....	A47F 5/02
			211/144

\* cited by examiner

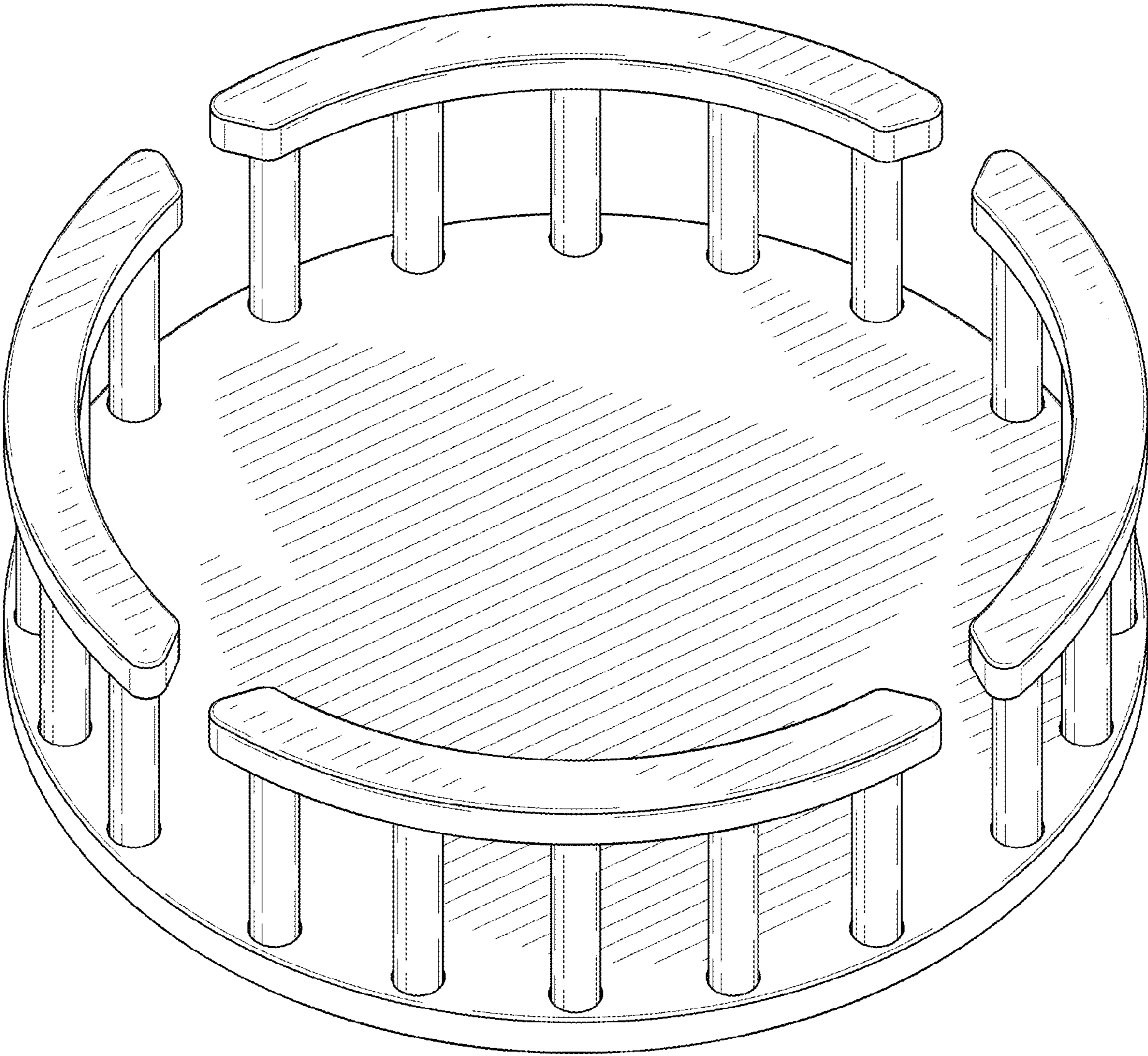

FIG. 1

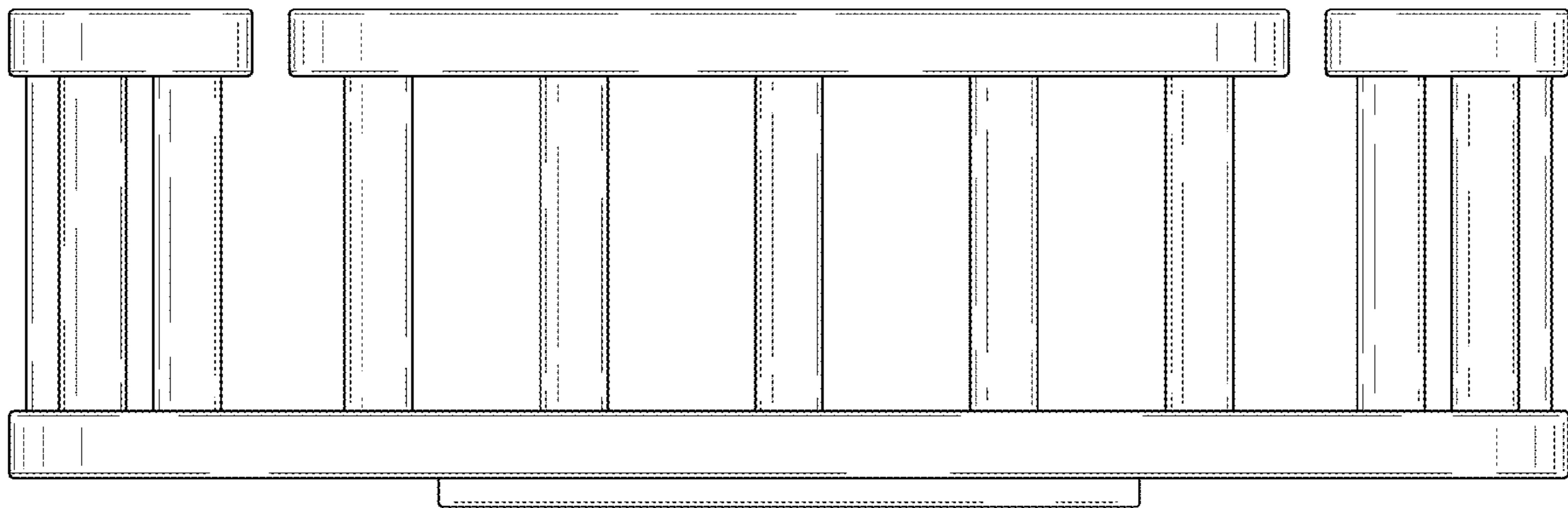

FIG. 2

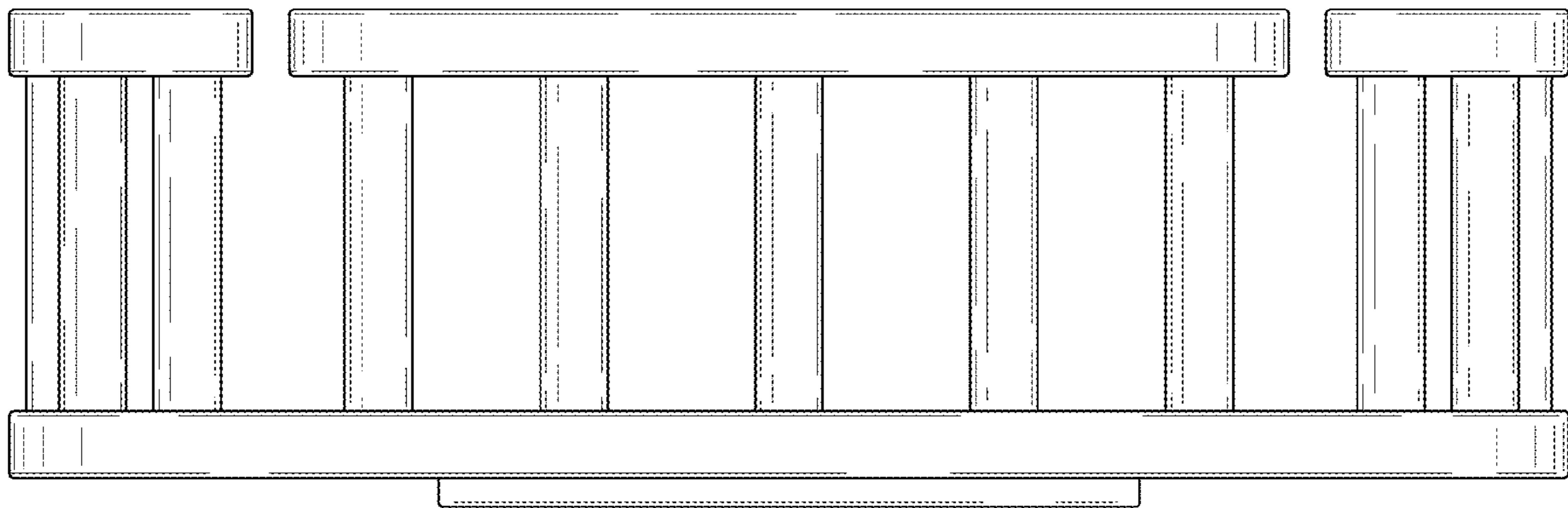

FIG. 3

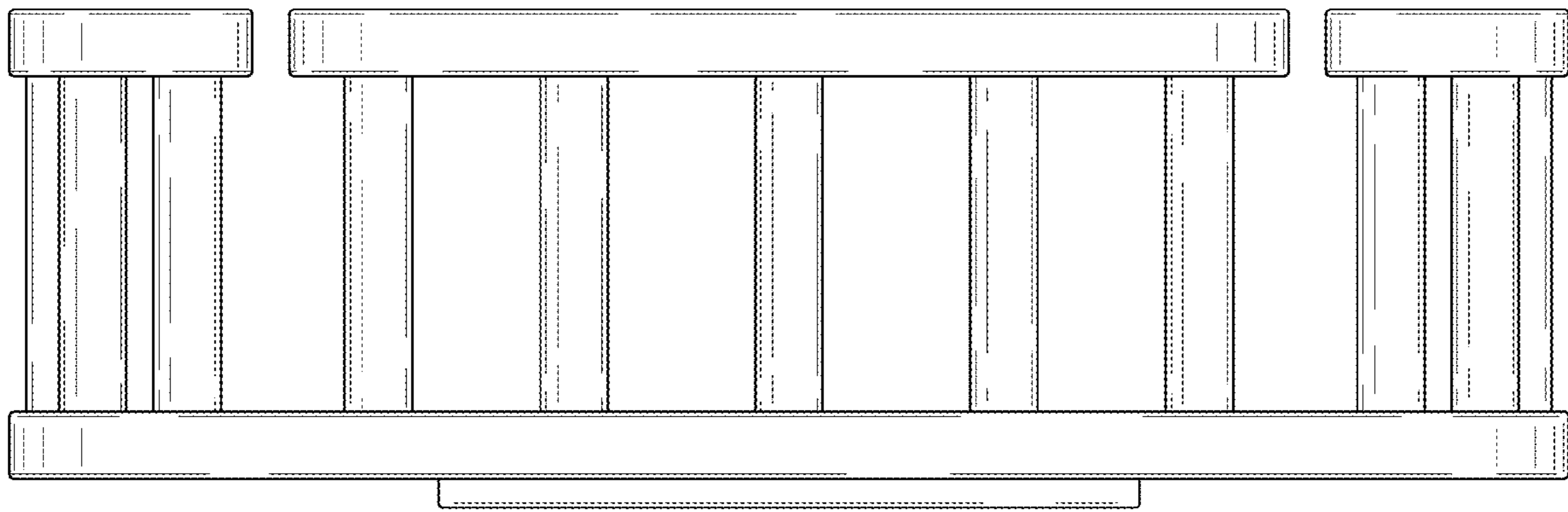

FIG. 4

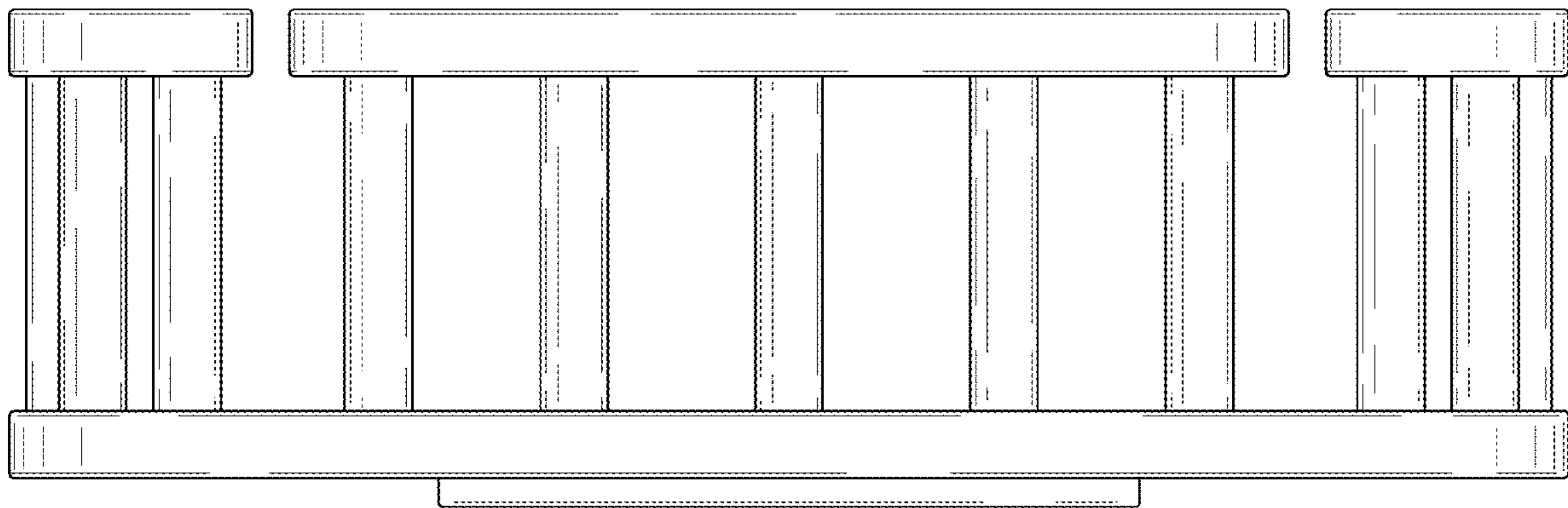

FIG. 5

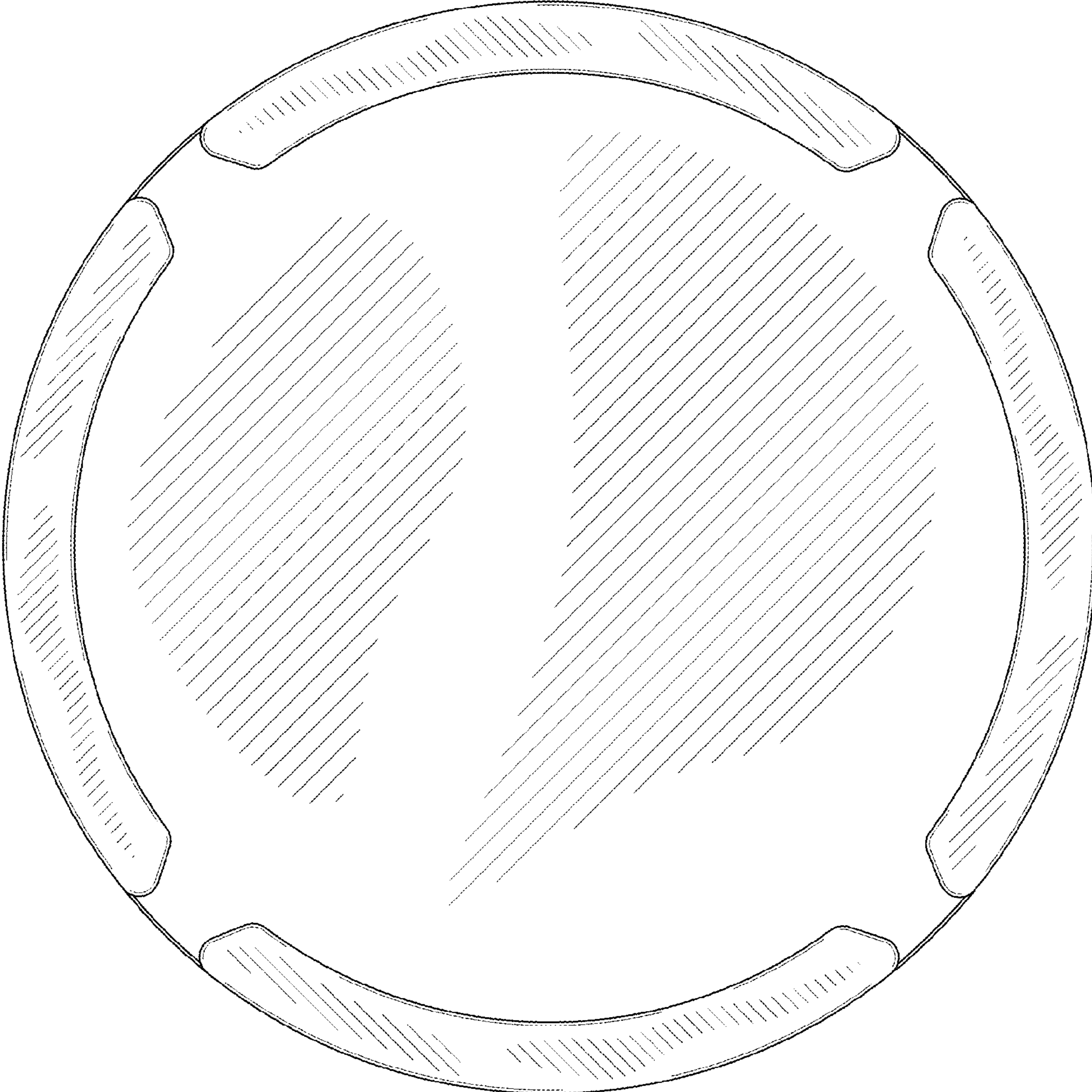

FIG. 6



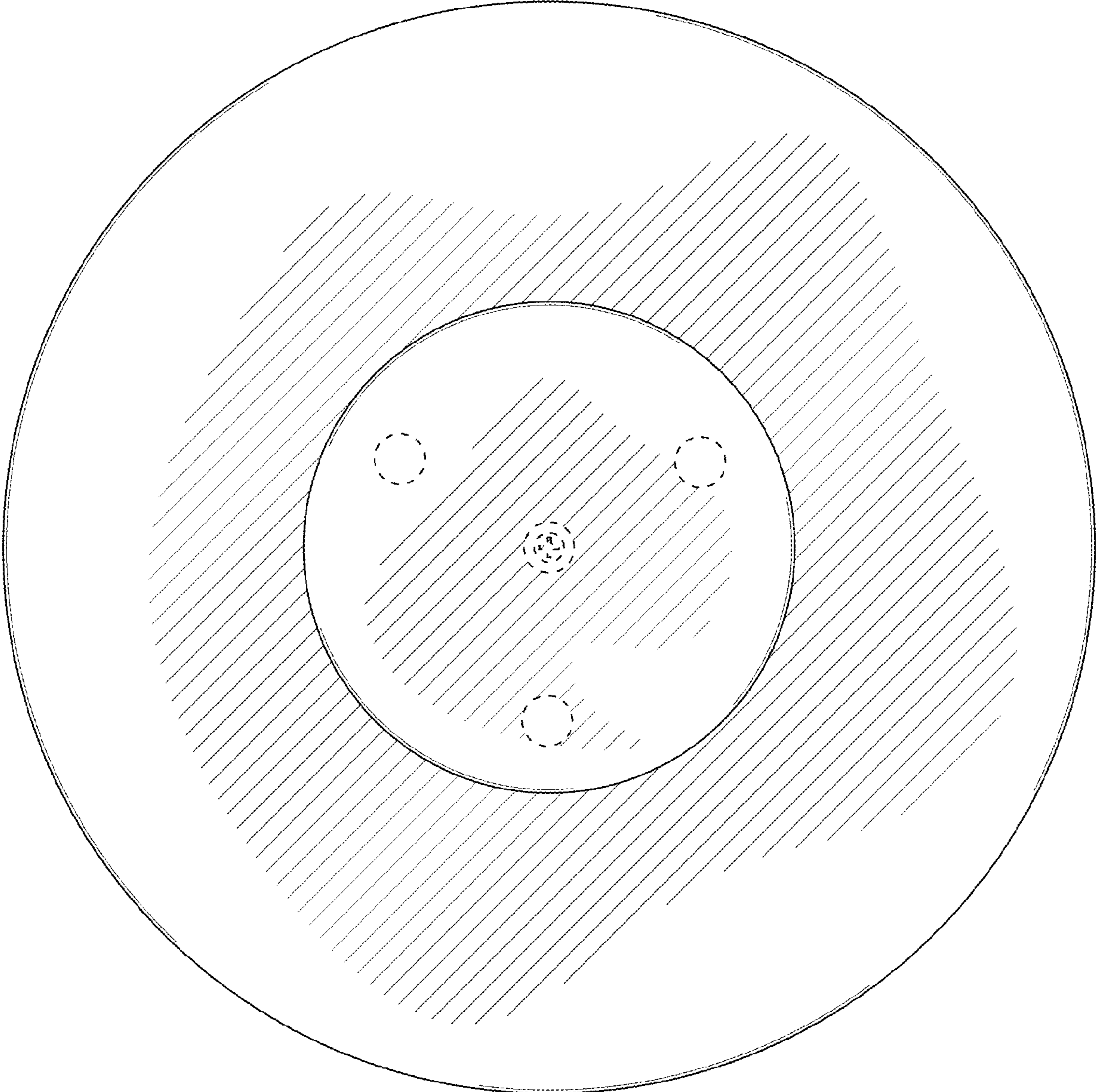

FIG. 7