



US00D951835S

(12) **United States Design Patent** (10) **Patent No.:** **US D951,835 S**  
**Manzoni** (45) **Date of Patent:** **\*\* May 17, 2022**

(54) **STEERING WHEEL**  
(71) Applicant: **Ferrari S.p.A.**, Modena (IT)  
(72) Inventor: **Flavio Manzoni**, Maranello (IT)  
(73) Assignee: **FERRARI S.p.A.**, Modena (IT)  
(\*\*) Term: **15 Years**  
(21) Appl. No.: **29/784,813**

D792,299 S \* 7/2017 Manzoni ..... D12/176  
D797,621 S \* 9/2017 Ogawa ..... D12/176  
D814,999 S \* 4/2018 Lokers ..... D12/176  
D820,177 S \* 6/2018 Buffery ..... D12/176  
D827,522 S \* 9/2018 Villamizar ..... D12/176  
D830,255 S \* 10/2018 Kawahara ..... D12/176  
D853,912 S \* 7/2019 Grewer ..... D12/176  
D858,383 S \* 9/2019 Wakou ..... D12/176  
D875,000 S \* 2/2020 Watola ..... D12/176  
D881,765 S \* 4/2020 Finney ..... D12/176  
D904,947 S \* 12/2020 Manzoni ..... D12/176

(Continued)

(22) Filed: **May 21, 2021**

**OTHER PUBLICATIONS**

**Related U.S. Application Data**

(62) Division of application No. 35/509,090, filed on Oct. 14, 2019 (U.S. filing date under 35 U.S.C. 384), and having an international filing date of Oct. 14, 2019, now Pat. No. Des. 938,878.

Tony Borroz. "Ferrari Builds a Steering Wheel Massa Would Love." Wired., Aug. 27, 2009 [online], [retrieved on Mar. 12, 2022]. Retrieved from the Internet <URL: <https://www.wired.com/2009/08/ferrari-steering-wheel/>>.\*

(Continued)

(30) **Foreign Application Priority Data**

Apr. 15, 2019 (EM) ..... 006377685

*Primary Examiner* — Darlington Ly

(74) *Attorney, Agent, or Firm* — Cowan, Liebowitz & Latman, P.C.; Anastasia Zhadina

(51) **LOC (13) Cl.** ..... **12-16**

(52) **U.S. Cl.**  
USPC ..... **D12/176**

(57) **CLAIM**

The ornamental design for a steering wheel, as shown and described.

(58) **Field of Classification Search**  
USPC ..... D12/175, 176, 177  
CPC ..... B60R 21/203; B60R 21/05; B62D 1/04  
See application file for complete search history.

**DESCRIPTION**

FIG. 1 is a front perspective view of a steering wheel embodying my new design;  
FIG. 2 is a front elevation view thereof;  
FIG. 3 is a rear elevation view thereof;  
FIG. 4 is a right side elevation view thereof;  
FIG. 5 is a left side elevation view thereof;  
FIG. 6 is a top plan view thereof; and,  
FIG. 7 is a bottom plan view thereof.  
Portions of the steering wheel shown in broken lines form no part of the claimed design.

(56) **References Cited**

**U.S. PATENT DOCUMENTS**

D521,913 S \* 5/2006 Nakamura ..... D12/176  
D633,835 S \* 3/2011 Frank ..... D12/176  
D653,179 S \* 1/2012 Frank ..... D12/176  
D653,594 S \* 2/2012 Frank ..... D12/176  
D659,613 S \* 5/2012 Tanaka ..... D12/176  
D707,162 S \* 6/2014 Finney ..... D12/175  
D758,932 S \* 6/2016 Schowalter ..... D12/176  
D773,968 S \* 12/2016 Blachere ..... D12/176

**1 Claim, 7 Drawing Sheets**

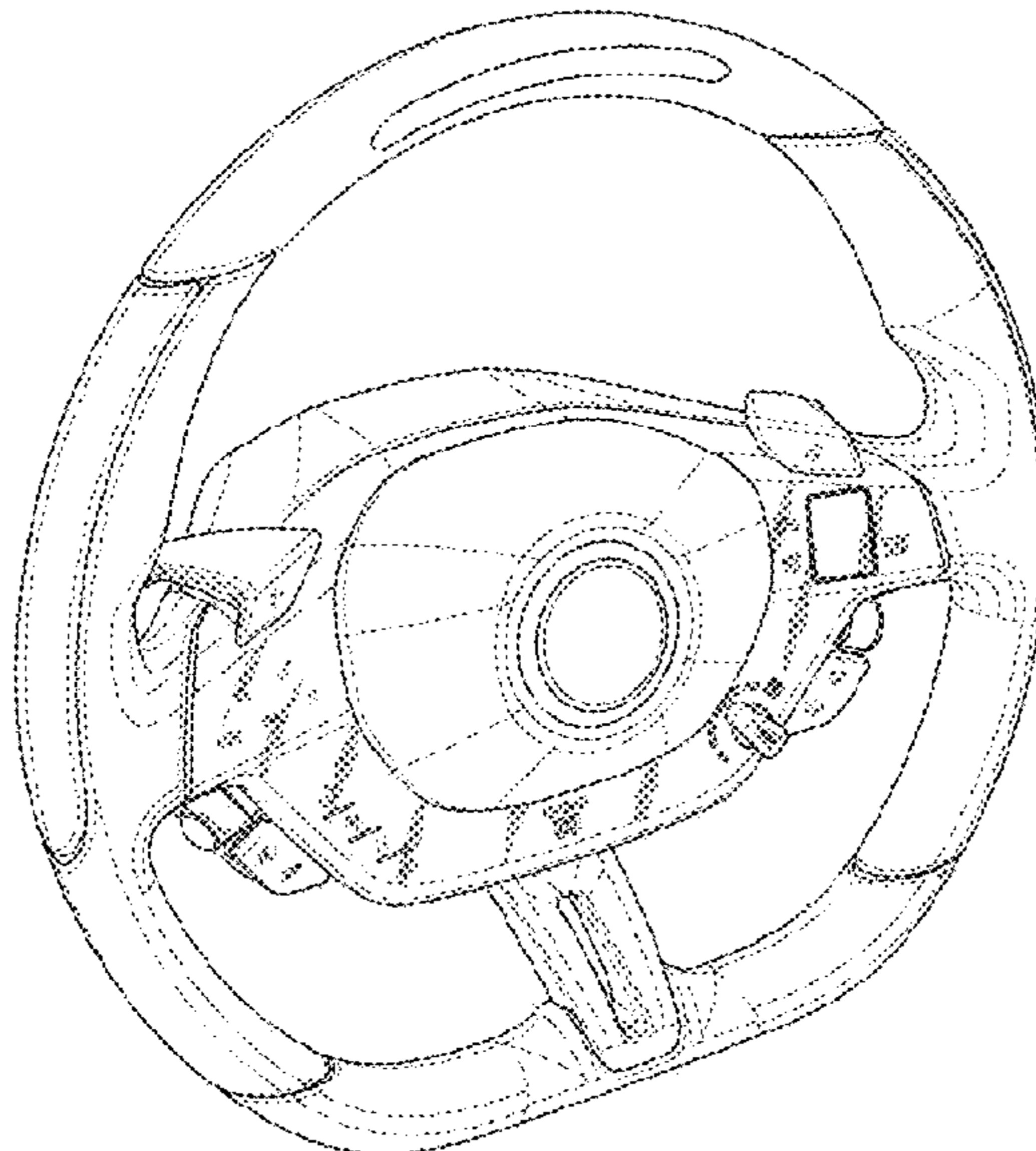

(56)

**References Cited**

U.S. PATENT DOCUMENTS

D909,935 S \* 2/2021 Galdino ..... D12/176  
10,926,786 B2 \* 2/2021 Jendrowski ..... B60K 35/00  
10,933,900 B2 \* 3/2021 Spencer ..... B62D 1/06  
11,034,374 B2 \* 6/2021 Banno ..... B60R 21/2037  
D924,757 S \* 7/2021 Yu ..... D12/176  
D925,417 S \* 7/2021 Hamada ..... D12/176  
11,066,092 B2 \* 7/2021 Nonoyama ..... B62D 1/06

OTHER PUBLICATIONS

Karla Sanchez. "Feature Flick: Ferrari 458 Italia Controls Explained." Motor Trend., May 3, 2011 [online], [retrieved on Mar. 12, 2022]. Retrieved from the Internet <URL: <https://www.motortrend.com/news/feature-flick-ferrari-458-italia-cockpit-exposed-44509/>>.\*  
Auto Express Team. "New 2021 Ferrari 296 GTB launched with 819bhp V6 hybrid powertrain . . ." Auto Express., Jun. 24, 2011 [online], [retrieved on Mar. 12, 2022]. Retrieved from the Internet <URL: <https://www.autoexpress.co.uk/ferrari/355337/new-2021-ferrari-296-gtb-launched-819bhp-v6-hybrid-powertrain-pictures>>.\*

\* cited by examiner

FIG. 1

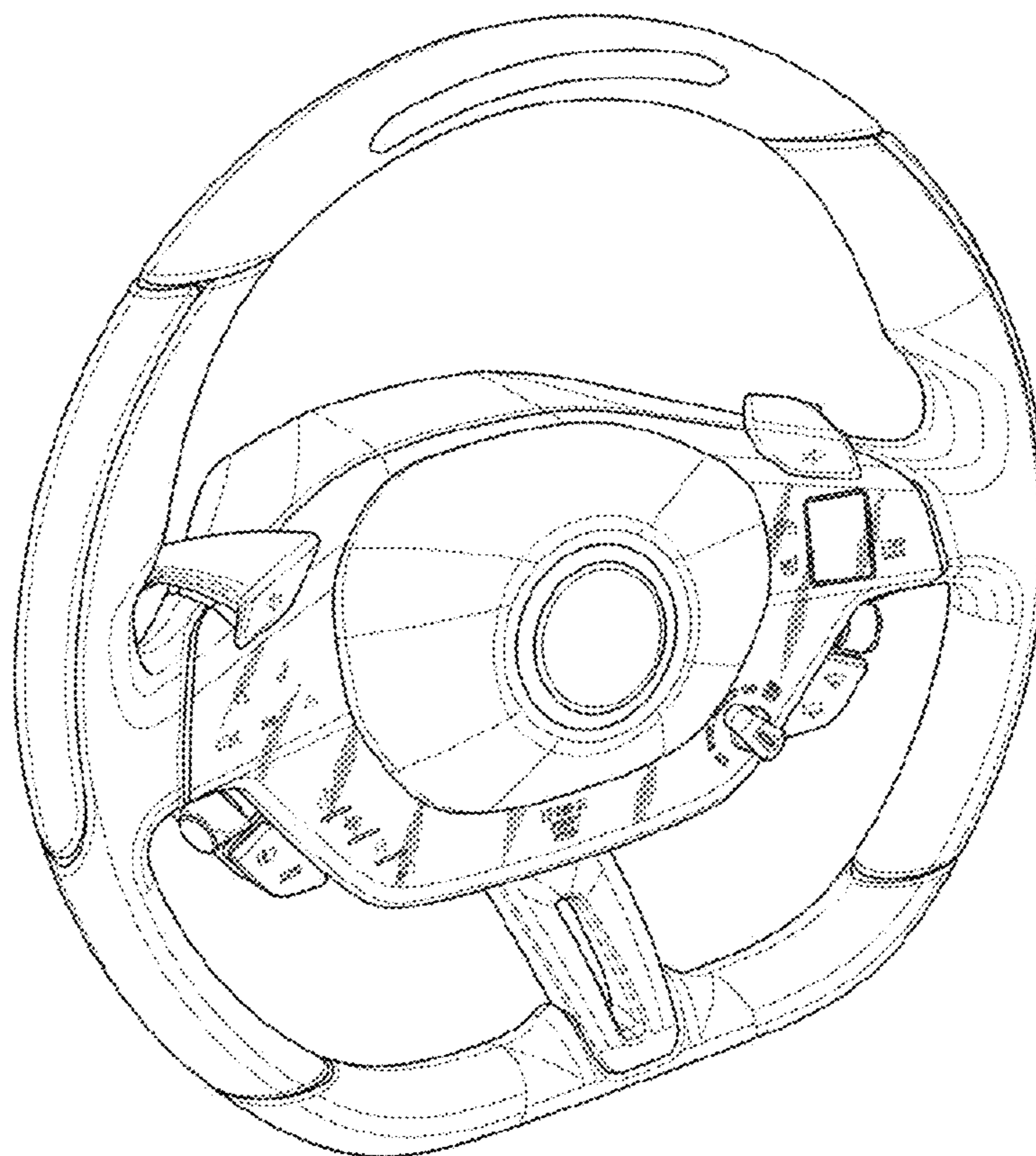

FIG. 2

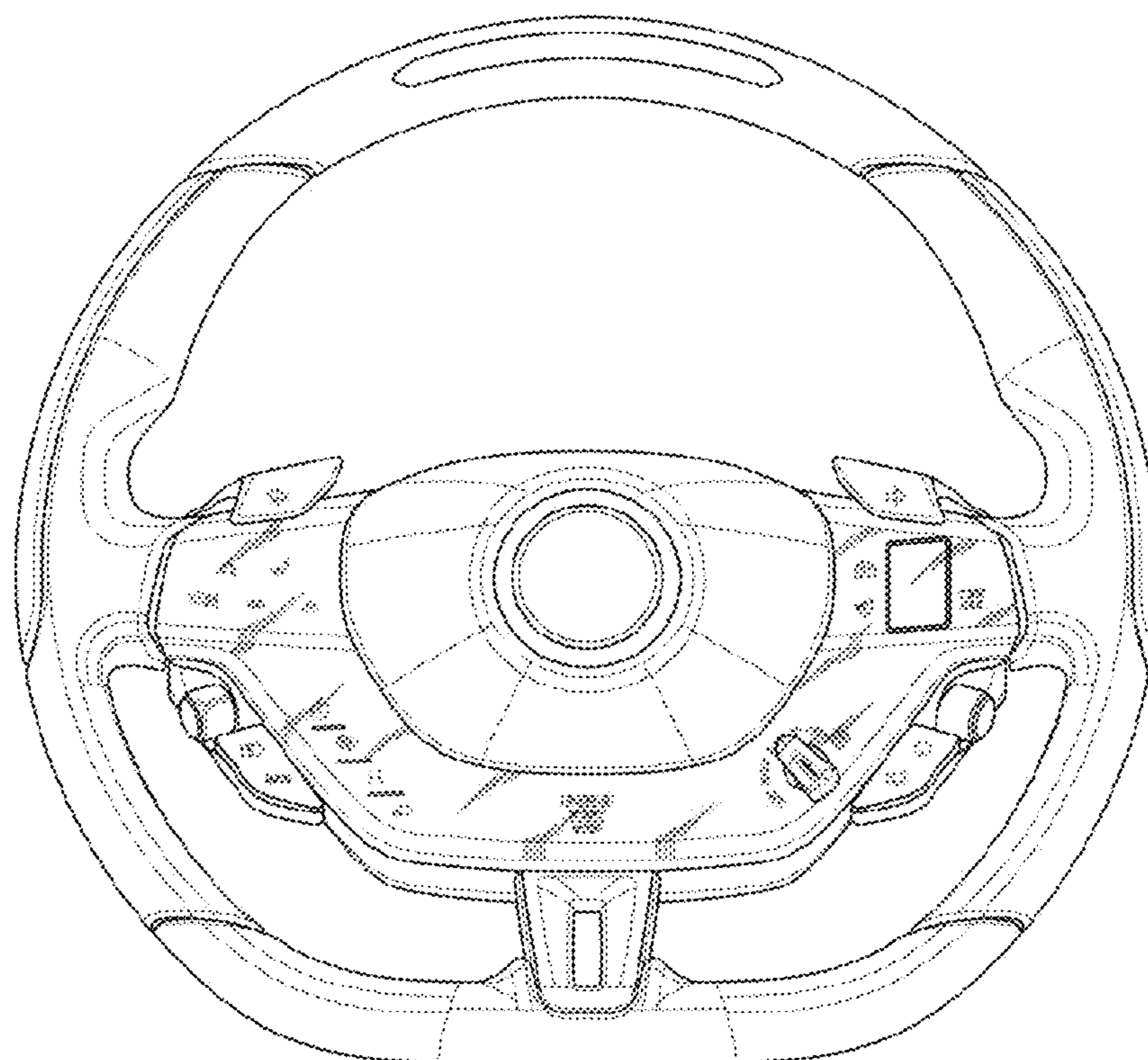



FIG. 3

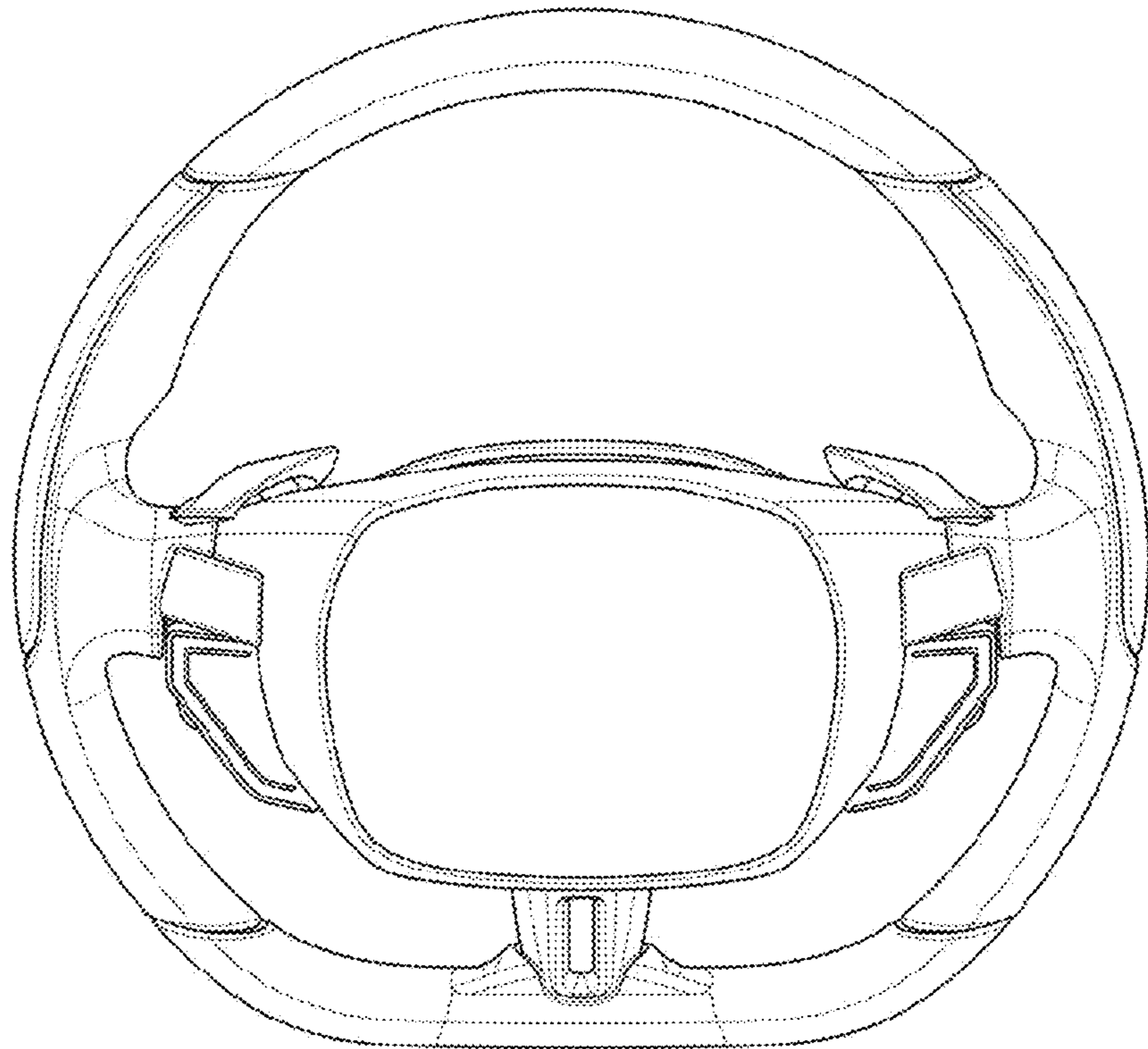

FIG. 4

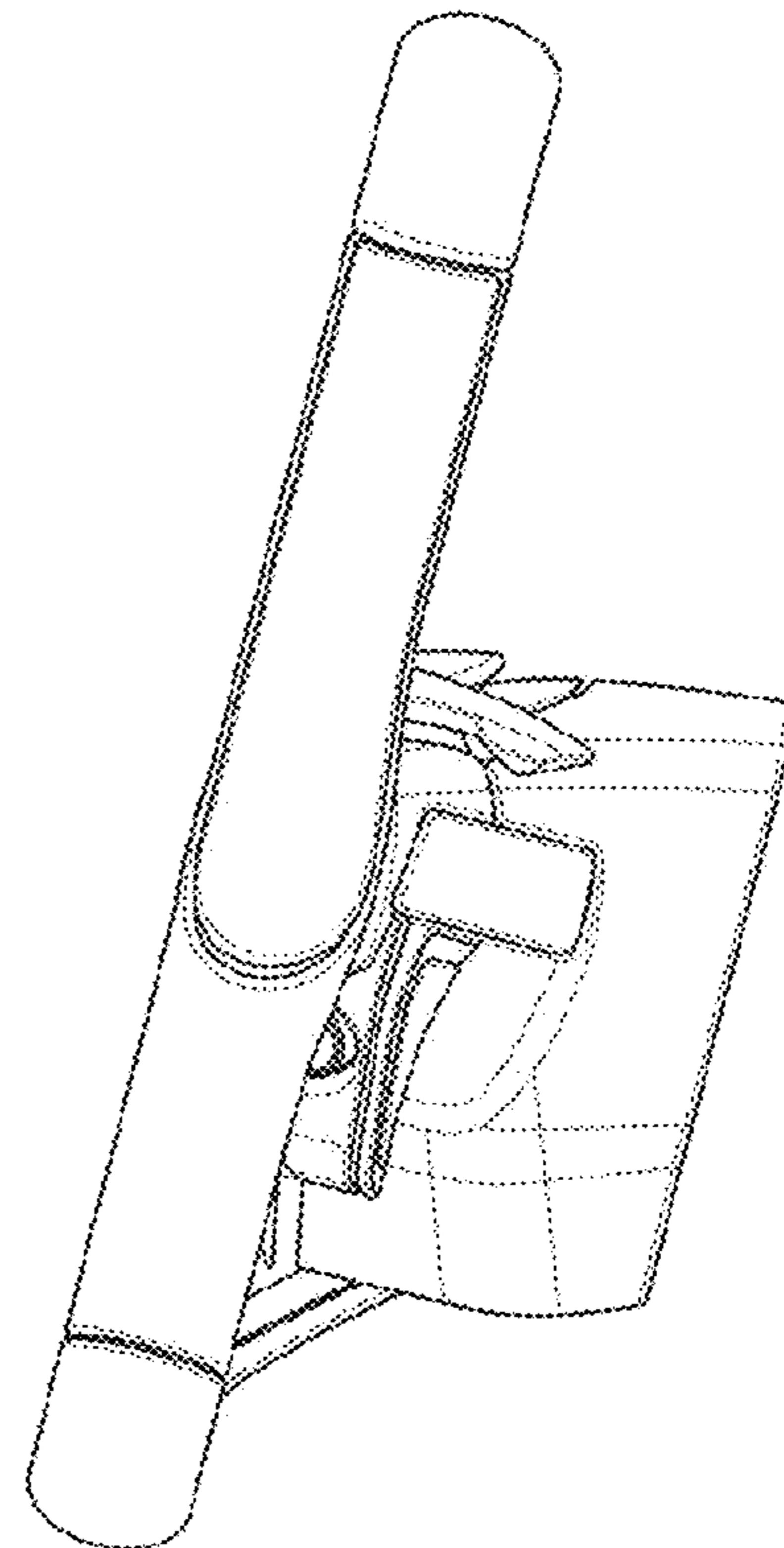

FIG. 5

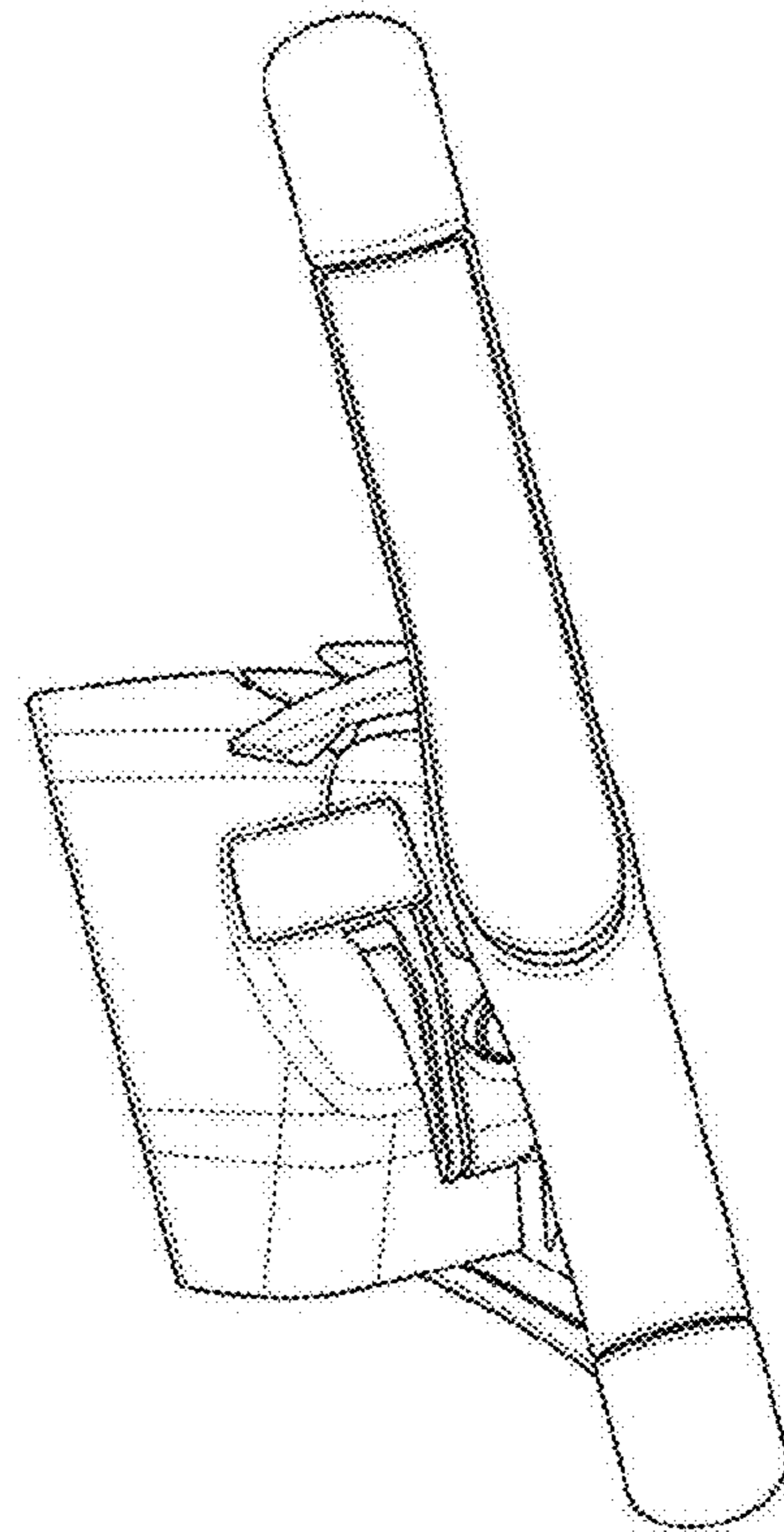

FIG. 6

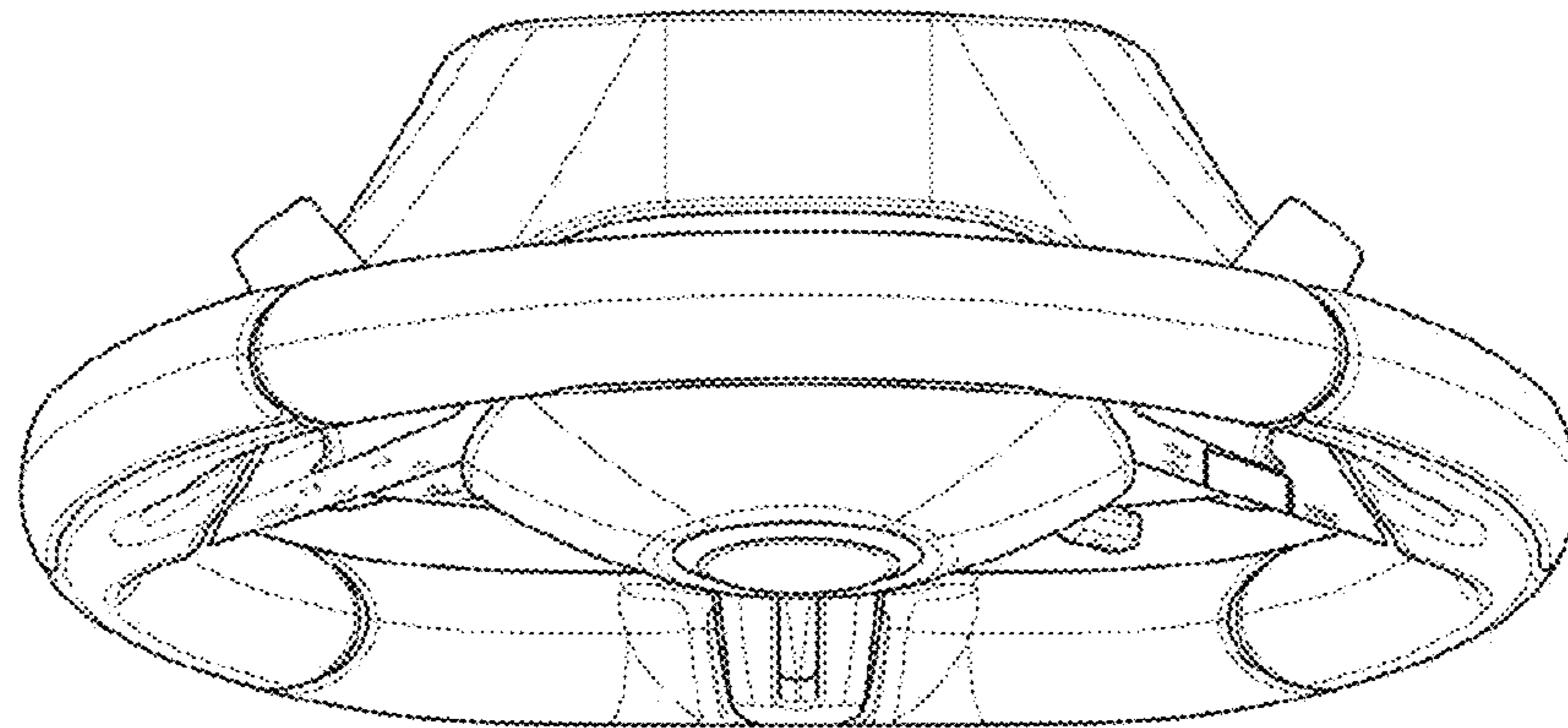



FIG. 7

