

US00D951481S

(12) **United States Design Patent** (10) **Patent No.:** **US D951,481 S**
Hudson et al. (45) **Date of Patent:** **** May 10, 2022**

(54) **CRYOGENIC VIAL**

(71) Applicant: **TMRW LIFE SCIENCES, INC.**, New York, NY (US)

(72) Inventors: **Cynthia Hudson**, New York, NY (US); **Timothy Alan Sharp**, Farmingdale, NY (US); **Brian Joseph Bixon**, Jersey City, NJ (US)

(73) Assignee: **TMRW LIFE SCIENCES, INC.**, New York, NY (US)

(**) Term: **15 Years**

(21) Appl. No.: **29/748,815**

(22) Filed: **Sep. 1, 2020**

(51) **LOC (13) Cl.** **24-02**

(52) **U.S. Cl.**
USPC **D24/224**

(58) **Field of Classification Search**
USPC D24/169, 216, 222–226, 231, 232; D28/85–87; D19/163, 181; D9/500, 537, D9/539, 544, 545, 549, 558, 574; D3/203.1–203.8
CPC A01N 1/0268; B65D 1/02; B65D 1/023; G01N 21/718; C03C 3/091; B01L 3/5021; B01L 3/50825
See application file for complete search history.

6,329,139 B1 12/2001 Nova et al.
6,564,120 B1 5/2003 Richard et al.
D496,398 S * 9/2004 Greenberg D19/163
D506,550 S * 6/2005 Greenberg D24/133
7,070,053 B1 7/2006 Abrams et al.
7,091,864 B2 8/2006 Veitch et al.
7,278,328 B2 10/2007 Massaro
7,316,896 B2 1/2008 Kuwayama et al.
7,350,703 B2 4/2008 Ambartsoumian
7,411,508 B2 8/2008 Harazin et al.
7,661,591 B2 2/2010 Dearing et al.
7,694,886 B2 4/2010 Tan et al.
7,870,748 B2 1/2011 Byrne
D642,697 S 8/2011 Gaefvert
8,097,199 B2 1/2012 Abbott et al.
8,098,162 B2 1/2012 Abbott et al.
8,115,599 B2 2/2012 Harazin et al.
8,168,138 B2 5/2012 Che et al.
8,378,827 B2 2/2013 Davidowitz et al.
8,502,645 B2 8/2013 Thomas et al.
8,710,958 B2 4/2014 Yang et al.
8,790,597 B2 7/2014 Childs et al.
8,852,536 B2 10/2014 Davidowitz et al.
8,872,627 B2 10/2014 Davidowitz
8,884,743 B2 11/2014 Chaffey et al.
8,937,550 B2 1/2015 Phaneuf et al.
9,028,754 B2 5/2015 Winter et al.
9,140,487 B2 9/2015 Chaffey et al.
9,163,869 B2 10/2015 Warhurst et al.
9,211,540 B2 12/2015 Lansdowne
9,297,499 B2 3/2016 Jimenez-Rios et al.
9,418,265 B2 8/2016 Morris et al.
9,431,692 B2 8/2016 Davidowitz et al.
D768,868 S 10/2016 Inoue
9,501,734 B2 11/2016 Morris
9,516,876 B2 12/2016 Inoue
9,538,746 B2 1/2017 Inoue
9,538,747 B2 1/2017 Inoue
9,547,782 B2 1/2017 Lansdowne
9,551,649 B2 1/2017 Houghton et al.
9,589,225 B2 3/2017 Morris
9,619,678 B2 4/2017 Morris et al.
9,697,457 B2 7/2017 Morris
9,723,832 B2 8/2017 Camenisch et al.
9,736,890 B2 8/2017 Chaffey et al.
9,764,325 B2 9/2017 Davidowitz
9,796,574 B2 10/2017 Frey et al.
9,928,457 B2 3/2018 Mcdowell
D816,165 S * 4/2018 Haug D19/163
10,207,270 B2 2/2019 Lansdowne
10,328,431 B2 6/2019 Davidowitz
10,401,082 B2 9/2019 Coradetti et al.
10,493,457 B2 12/2019 Croquette et al.

(56) **References Cited**

U.S. PATENT DOCUMENTS

D155,031 S * 8/1949 Patterson D9/521
4,573,581 A 3/1986 Galloway et al.
D310,264 S * 8/1990 Leoncavallo D24/224
5,355,684 A 10/1994 Guice
5,545,562 A 8/1996 Cassou et al.
5,741,462 A 4/1998 Nova et al.
5,751,629 A 5/1998 Nova et al.
5,874,214 A 2/1999 Nova et al.
5,925,562 A 7/1999 Nova et al.
6,100,026 A 8/2000 Nova et al.
6,141,975 A 11/2000 Tatsumi
6,156,566 A 12/2000 Bryant

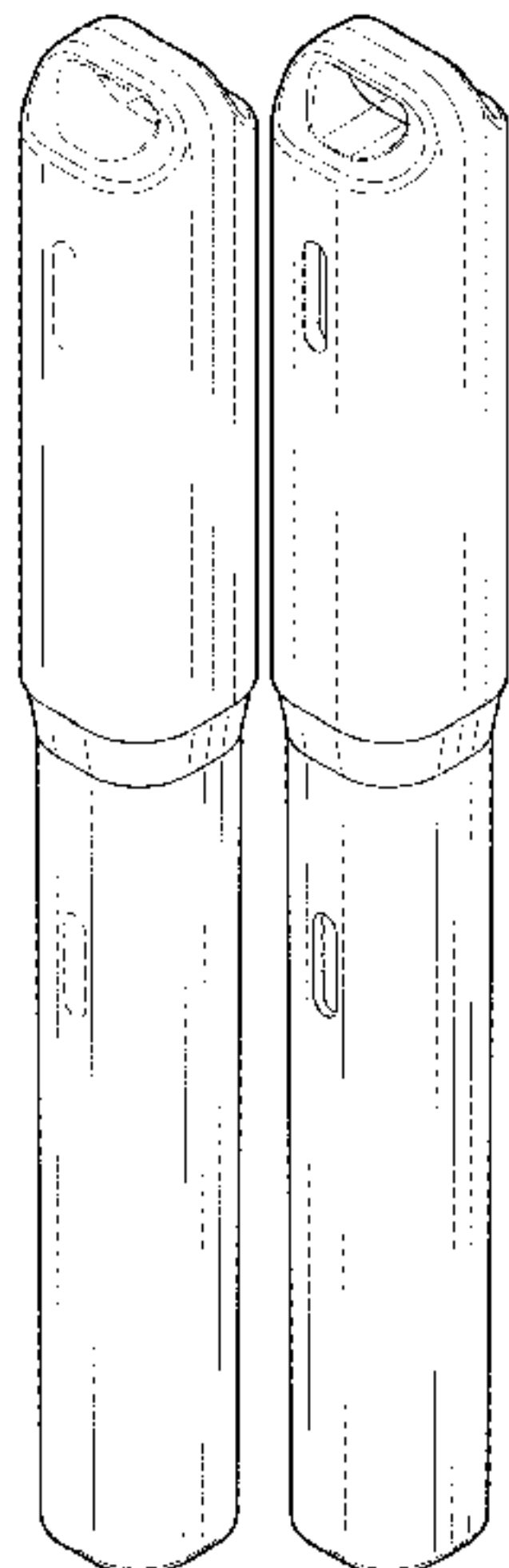

US D951,481 S

10,531,657	B2	1/2020	Farrington et al.	2018/0100868	A1	4/2018	Grimwood et al.
10,561,141	B2	2/2020	Suzuki et al.	2018/0135806	A1	5/2018	Qu et al.
10,677,810	B2	6/2020	Grimwood et al.	2018/0202908	A1	7/2018	Croquette et al.
D890,948	S *	7/2020	Figueredo D24/224	2018/0368394	A1	12/2018	Kjelland et al.
10,748,050	B2	8/2020	Morris et al.	2019/0000073	A1	1/2019	Pedersen et al.
D910,836	S *	2/2021	Sandberg D24/112	2019/0060892	A1	2/2019	Davidowitz et al.
10,989,636	B2	4/2021	Gutelius et al.	2019/0193078	A1	6/2019	Fiondella et al.
D931,128	S *	9/2021	Li D10/78	2019/0250181	A1	8/2019	Seeber
D932,906	S *	10/2021	Schulz D9/549	2019/0276233	A1	9/2019	Caveney et al.
11,148,143	B2	10/2021	Davidowitz et al.	2019/0293344	A1	9/2019	Sun et al.
D938,053	S *	12/2021	Xiao D24/194	2019/0297877	A1	10/2019	Komatsu et al.
2002/0190845	A1	12/2002	Moore	2020/0093122	A1 *	3/2020	Lin A01N 1/0268
2002/0196146	A1	12/2002	Moore	2020/0281191	A1 *	9/2020	Ally A01N 1/0268
2003/0174046	A1	9/2003	Abrams	FOREIGN PATENT DOCUMENTS			
2004/0100415	A1	5/2004	Veitch et al.	AU	2011357590	B2	9/2015
2005/0237195	A1	10/2005	Urban	CN	108541702	A	9/2018
2005/0247782	A1	11/2005	Ambartsoumian	CN	111771211	A	10/2020
2006/0051239	A1	3/2006	Massaro	EP	0706825	A1	4/1996
2006/0283945	A1	12/2006	Excoffier et al.	EP	1366998	A3	3/2004
2007/0068208	A1	3/2007	Norman et al.	EP	1366998	B1	1/2006
2008/0012687	A1	1/2008	Rubinstein	EP	1916492	A1	4/2008
2008/0121700	A1	5/2008	Dearing et al.	EP	2301857	A1	3/2011
2008/0239478	A1	10/2008	Tafas et al.	EP	2315163	A1	4/2011
2009/0015430	A1	1/2009	Harazin et al.	EP	2124171	B1	8/2012
2009/0026907	A1	1/2009	Davidowitz et al.	EP	1888239	B1	10/2014
2009/0318751	A1	12/2009	Lansdowne	EP	1981692	B1	6/2015
2010/0028214	A1	2/2010	Howard et al.	EP	2498968	B1	9/2015
2010/0141384	A1	6/2010	Chen et al.	EP	2335182	B1	10/2015
2010/0302040	A1	12/2010	Davidowitz et al.	EP	2297736	B1	2/2016
2011/0137812	A1	6/2011	Sherga	EP	2292332	B1	7/2016
2011/0143452	A1	6/2011	Che et al.	EP	2765183	B1	7/2016
2011/0181875	A1	7/2011	Nakahana et al.	EP	3655892	A1	5/2020
2011/0199187	A1	8/2011	Davidowitz	ES	2467465	A2	6/2014
2011/0199188	A1	8/2011	Dickson	JP	2005321935	A	11/2005
2011/0308271	A1	12/2011	Schryver	JP	2008021082	A	1/2008
2011/0312102	A1	12/2011	Jo	JP	5278978	B2	5/2013
2012/0060514	A1	3/2012	Warhurst et al.	WO	0194016	A1	12/2001
2012/0060520	A1	3/2012	Collins et al.	WO	02081743	A2	10/2002
2012/0060539	A1	3/2012	Hunt et al.	WO	03061381	A1	7/2003
2012/0060541	A1	3/2012	Hunt et al.	WO	2004026661	A1	4/2004
2012/0064603	A1	3/2012	Childs et al.	WO	2005093641	A1	10/2005
2012/0256806	A1	10/2012	Davidowitz et al.	WO	2005109332	A1	11/2005
2012/0272500	A1	11/2012	Reuteler	WO	2005115621	A1	12/2005
2012/0293338	A1	11/2012	Chaffey et al.	WO	2006029110	A1	3/2006
2013/0011226	A1	1/2013	Camenisch et al.	WO	2007024540	A1	3/2007
2013/0048711	A1	2/2013	Burns et al.	WO	2007049039	A1	5/2007
2013/0076215	A1	3/2013	Davidowitz et al.	WO	2007075253	A2	7/2007
2013/0106579	A1	5/2013	Aubert et al.	WO	2007092119	A1	8/2007
2013/0119562	A1	5/2013	Shimizu et al.	WO	2008024471	A2	2/2008
2013/0151004	A1	6/2013	Winter et al.	WO	2008057150	A1	5/2008
2013/0152710	A1	6/2013	Laugharn et al.	WO	2009004366	A1	1/2009
2013/0217107	A1	8/2013	Pederson et al.	WO	2009017558	A1	2/2009
2014/0008355	A1	1/2014	Chaffey et al.	WO	2009120596	A1	10/2009
2014/0157798	A1	6/2014	Jimenez-Rios et al.	WO	2009155638	A1	12/2009
2014/0171829	A1	6/2014	Holmes et al.	WO	2010037166	A1	4/2010
2014/0230472	A1	8/2014	Coradei et al.	WO	2011069190	A1	6/2011
2014/0352456	A1	12/2014	Davidowitz	WO	2012100281	A1	8/2012
2015/0045782	A1	2/2015	Ottanelli	WO	2012033605	A3	11/2012
2015/0122887	A1	5/2015	Morris et al.	WO	2012033994	A3	12/2012
2015/0125574	A1	5/2015	Arent et al.	WO	2012033992	A3	4/2013
2015/0204598	A1	7/2015	Affleck et al.	WO	2013053011	A1	4/2013
2015/0205986	A1	7/2015	Morris et al.	WO	2010014656	A3	5/2013
2015/0273468	A1	10/2015	Croquette et al.	WO	2012034037	A3	5/2013
2015/0356398	A1	12/2015	Morris	WO	2014001819	A1	1/2014
2015/0379390	A1	12/2015	Morris	WO	2014009729	A1	1/2014
2016/0026911	A1	1/2016	Morris et al.	WO	2014114938	A2	7/2014
2016/0095309	A1	4/2016	Reuteler	WO	2014157798	A1	10/2014
2016/0175837	A1	6/2016	Chaffey et al.	WO	2014191757	A1	12/2014
2016/0288999	A1	10/2016	Caveney et al.	WO	2015073964	A1	5/2015
2016/0289000	A1	10/2016	Caveney et al.	WO	2015109315	A3	10/2015
2016/0349172	A1	12/2016	Houghton et al.				
2016/0353730	A1	12/2016	Harston et al.				
2016/0358062	A1	12/2016	Morris				
2017/0113909	A1	4/2017	Frey et al.				
2017/0122846	A1	5/2017	Holmes et al.				
2017/0184479	A1	6/2017	Schryver et al.				
2017/0320054	A1	11/2017	Crum et al.				
2018/0020659	A1	1/2018	Camenisch et al.				
2018/0043364	A1	2/2018	Davidowitz				

WO 2016081755 A1 5/2016
 WO 2016120224 A1 8/2016

OTHER PUBLICATIONS

Cryogenic Vials, Standard. Online, published date unknown. Retrieved on Dec. 8, 2021 from URL: <https://www.nextdayscience.com/cryogenic-vials-standard.htm>.*

“IVF Witness System: RI Witness TM ART Management System”, Confidence, Efficiency and Trust, IVF Witness System—RI Witness—CooperSurgical Fertility Companies <https://fertility.coopersurgical.com/equipment/ri-witness>—Apr. 19, 2021, 28 pages.

“IVF Witness System: RI Witness TM ART Management System”, CooperSurgical Fertility Company 2021, 24 pages.

“RI Witness—Confidence, Efficiency and Trust”, CooperSurgical, Fertility and Genomic Solutions, Order No. WIT_BRO_001_V13_ROW—Oct. 13, 2020, 13 pages.

“RI Witness—Product guide”, CooperSurgical Fertility and Genomic Solutions, Order No. EQU_BRO_004, V1: Row Oct. 24, 2018, 12 pages.

Brady printer Range, “Everyone is Unique” Continual cryopreservation monitoring from RI Witness, CooperSurgical, Inc. Order No. WIT_FLY_010_V2_US Oct. 14, 2020, 3 pages.

Comley, J., “New approaches to sample identification tracking and technologies for maintaining the quality of stored samples,” Drug Discovery World Summer 2017, 11 pages.

CooperSurgical, RI Witness, Order No. CE 60010312 Version 3-ROW: Oct. 24, 2018, 12 pages.

FluidX Tri-Coded Jacket: 0.7ml Sample Storage Tube with External Thread; Brooks Life Sciences; <https://bioinventory.biostorage.com>.

HID Beyond Cool: RFID disentangles cryopreservation storage and management, 2015, 4 pages.

Ihmig et al., “Frozen cells and bits,” IEEE Pulse, Sep. 2013, 9 pages.

International Preliminary Report on Patentability and Written Opinion from PCT Application No. PCT/GB2005/002048 dated Aug. 23, 2005, 9 pages.

International Search Report and Written Opinion for PCT/US2020/060565, dated Mar. 8, 2021, 11 pages.

Non-Final Office Action Issued in U.S. Appl. No. 16/840,270, dated Sep. 21, 2021, 58 pages.

Office Action dated Sep. 3, 2020, for U.S. Appl. No. 16/840,718, 46 pages.

Maggiulli, Roberta , et al., “Implementing an electronic witnessing system into a busy IVF clinic—one clinic’s experience”, Genera Center for Reproductive Medicine, Rome, Italy, 2 pages.

Rienzi, Laura , et al., Poster Witness “Electronic Witness System makes patients less concerned about biological sample mix-up errors and comfortable with IOVF clinical practice”, Genera Center for Reproductive Medicine, Via de Notaris 2b, 00197, Rome, Italy. 2015, 1 page.

Swedberg, Claire , “Hitachi Chemical Markets Tiny UHF Tag”, <https://www.rfidjournal.com/hitachi-chemical-markets-tiny-uhf-tag>, Sep. 12, 2010, 4 pages.

Thornhill, A. R., et al., “Measuring human error in the IVF laboratory using an electronic witnessing system”, Monduzzi Editoriale,

Proceedings, 17th World Congress on Controversies in Obstetrics, Gynecology & Infertility (GOGI), Nov. 8-11, 2012 Lisbon, Portugal, 6 pages.

* cited by examiner

Primary Examiner — Susan Bennett Hattan
Assistant Examiner — Omeed Agilee
 (74) *Attorney, Agent, or Firm* — Cozen O’Connor

(57) **CLAIM**

The ornamental design for a cryogenic vial, as shown and described.

DESCRIPTION

FIG. 1 is a front, right side, top perspective view of a first embodiment of a cryogenic vial showing our new design; FIG. 2 is a rear, left side, bottom perspective view of the cryogenic vial illustrated in FIG. 1; FIG. 3 is a front elevation view of the cryogenic vial illustrated in FIG. 1; FIG. 4 is a right side elevation view of the cryogenic vial illustrated in FIG. 1; FIG. 5 is a left side elevation view of the cryogenic vial illustrated in FIG. 1; FIG. 6 is a rear elevation view of the cryogenic vial illustrated in FIG. 1; FIG. 7 is a top plan view of the cryogenic vial illustrated in FIG. 1; FIG. 8 is a bottom plan view of the cryogenic vial illustrated in FIG. 1; FIG. 9 is a front, right side, top perspective view of a second embodiment of a cryogenic vial showing our new design; FIG. 10 is a rear, left side, bottom perspective view of the cryogenic vial illustrated in FIG. 9; FIG. 11 is a front elevation view of the cryogenic vial illustrated in FIG. 9; FIG. 12 is a right side elevation view of the cryogenic vial illustrated in FIG. 9; FIG. 13 is a left side elevation view of the cryogenic vial illustrated in FIG. 9; FIG. 14 is a rear elevation view of the cryogenic vial illustrated in FIG. 9; FIG. 15 is a top plan view of the cryogenic vial illustrated in FIG. 9; and, FIG. 16 is a bottom plan view of the cryogenic vial illustrated in FIG. 9.

The dashed lines in the drawings depict portions of the cryogenic vial that form no part of the claimed design.

1 Claim, 10 Drawing Sheets

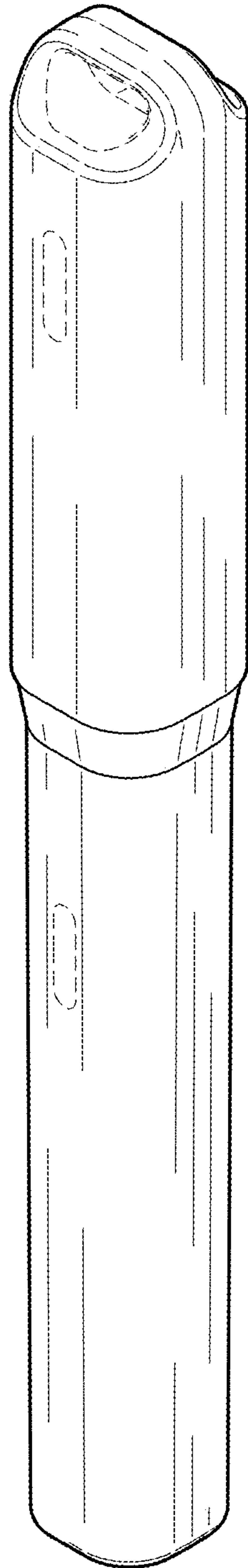

FIG. 1

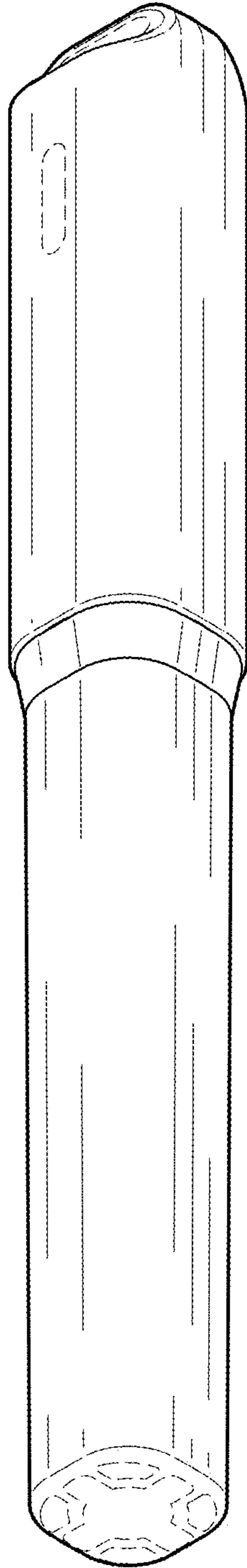

FIG. 2

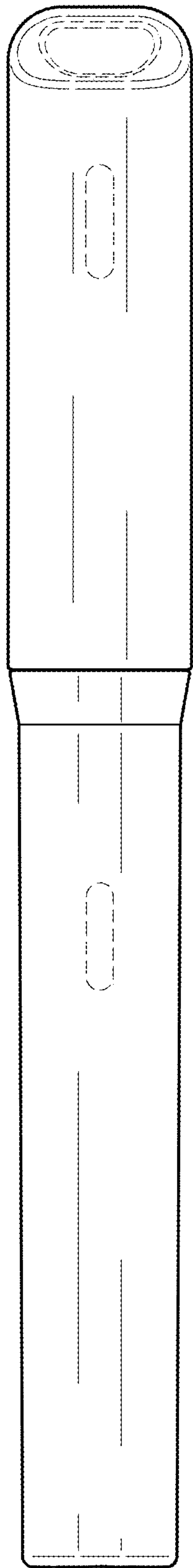

FIG. 3

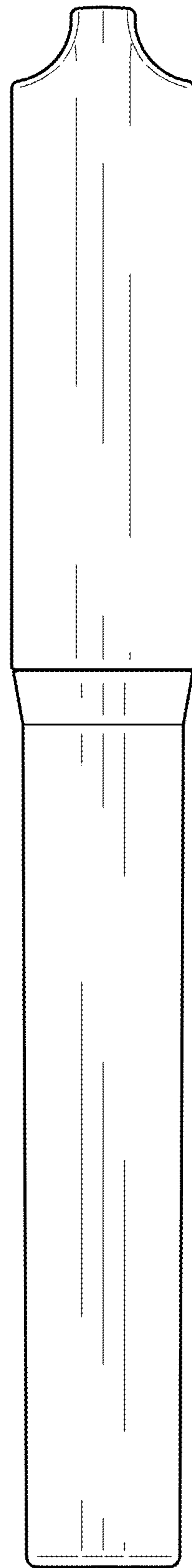

FIG. 4

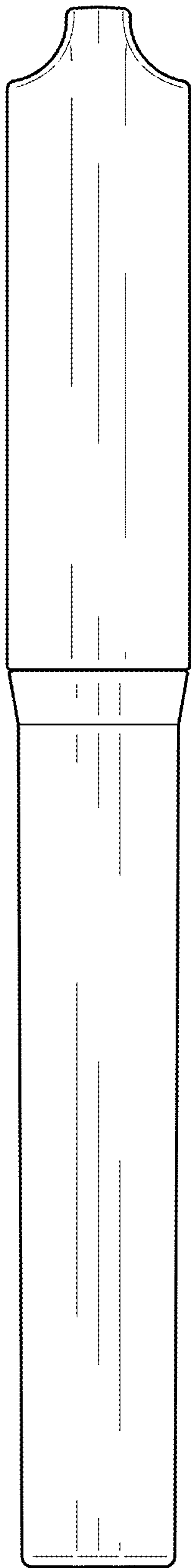

FIG. 5

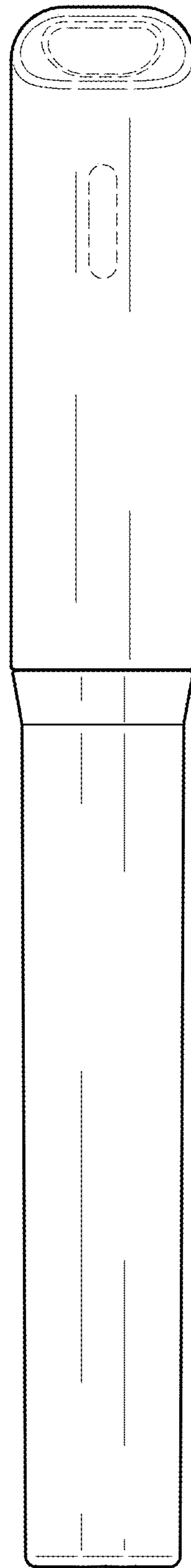

FIG. 6

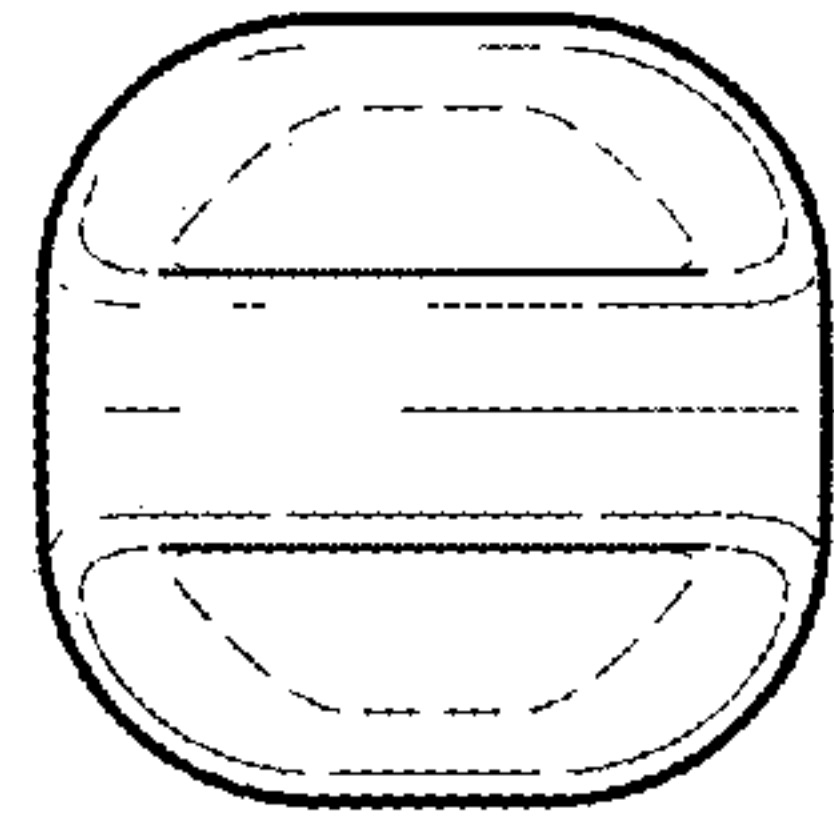

FIG. 7

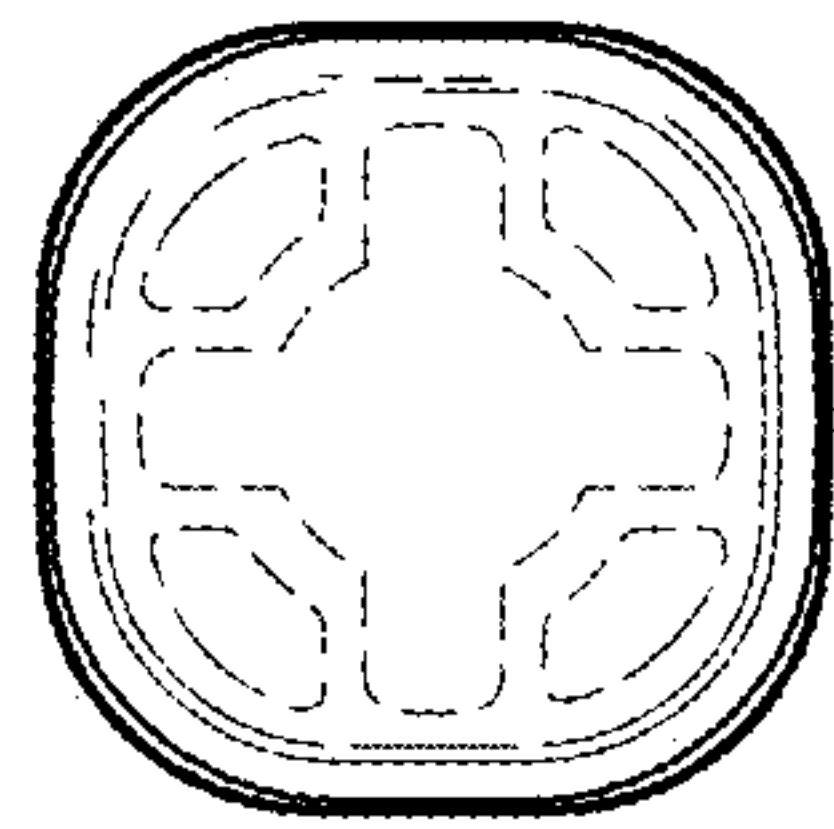

FIG. 8

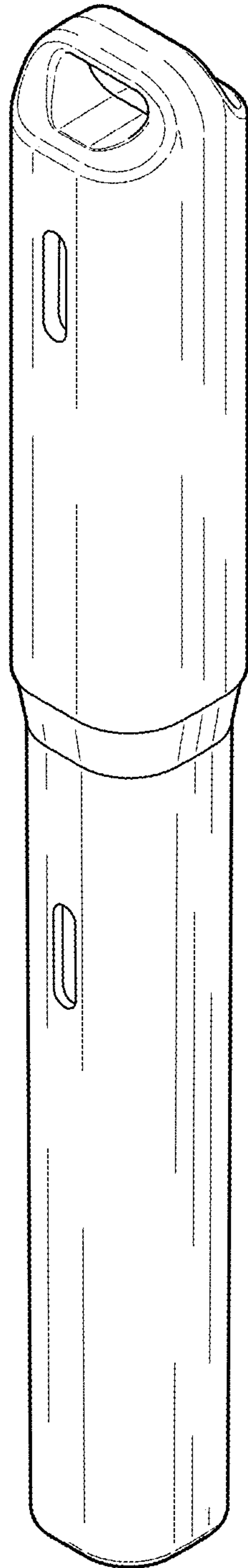

FIG. 9

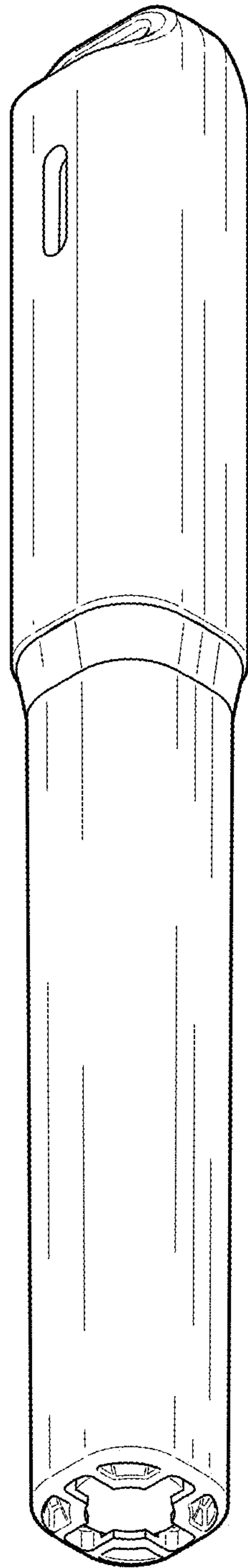

FIG. 10

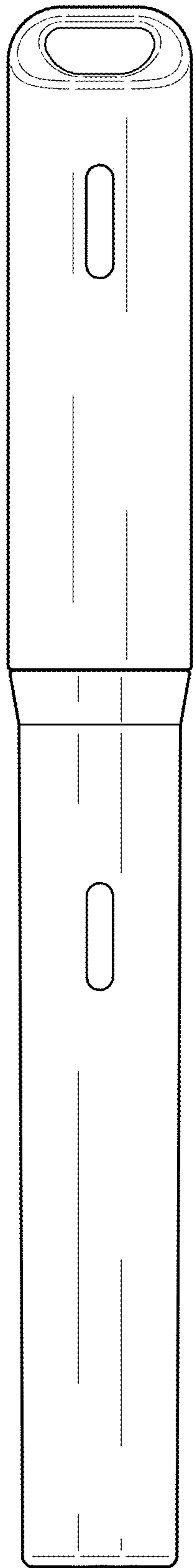

FIG. 11

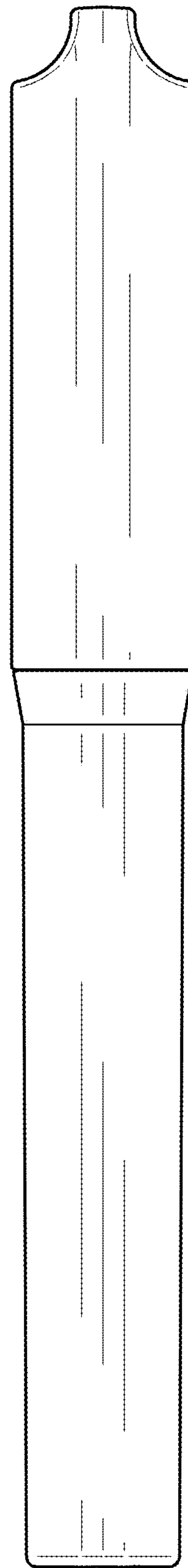

FIG. 12

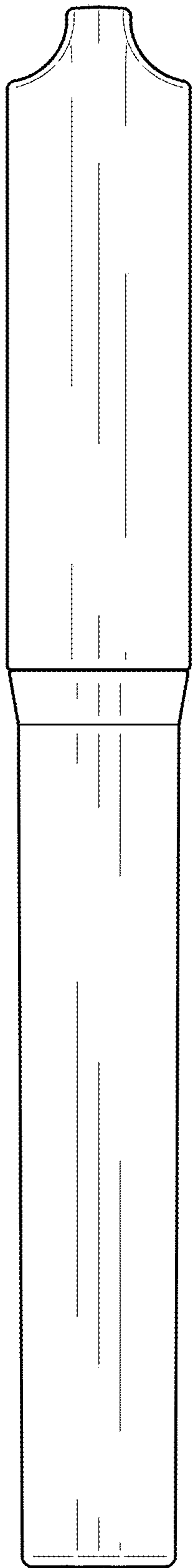

FIG. 13

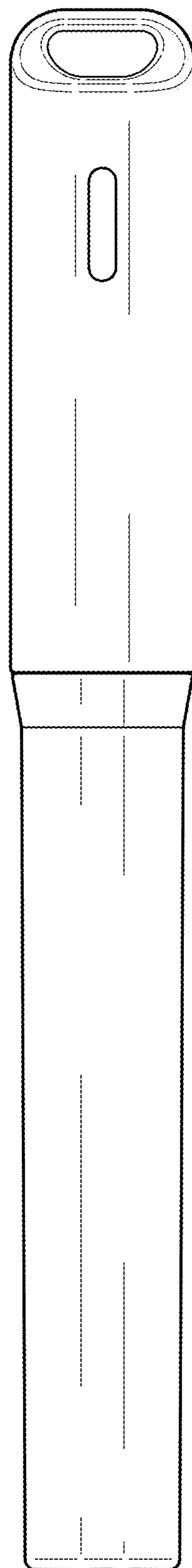

FIG. 14

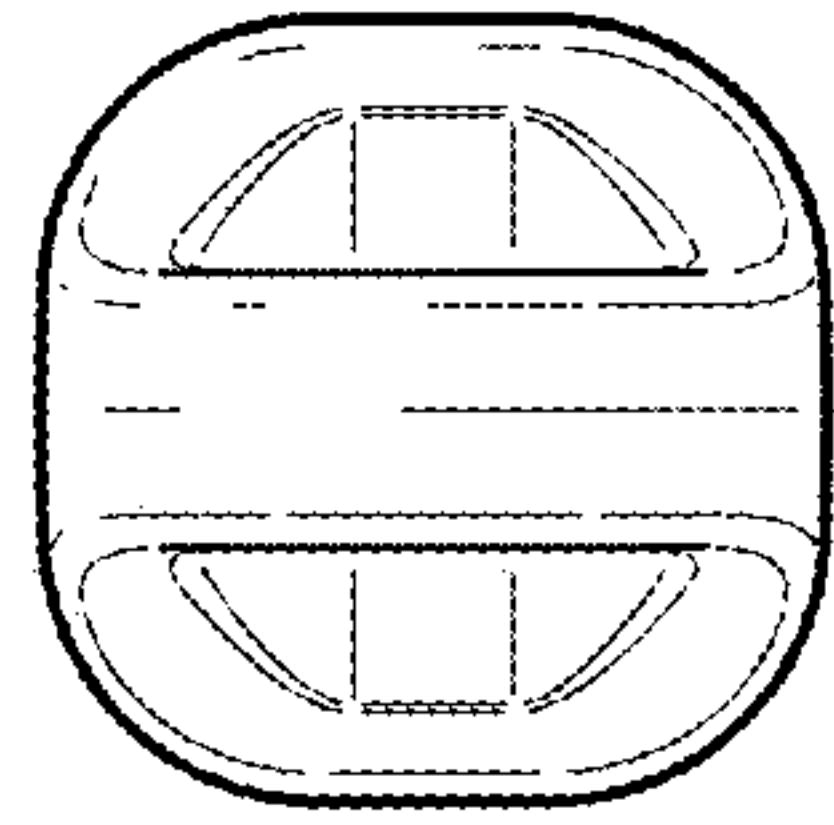

FIG. 15

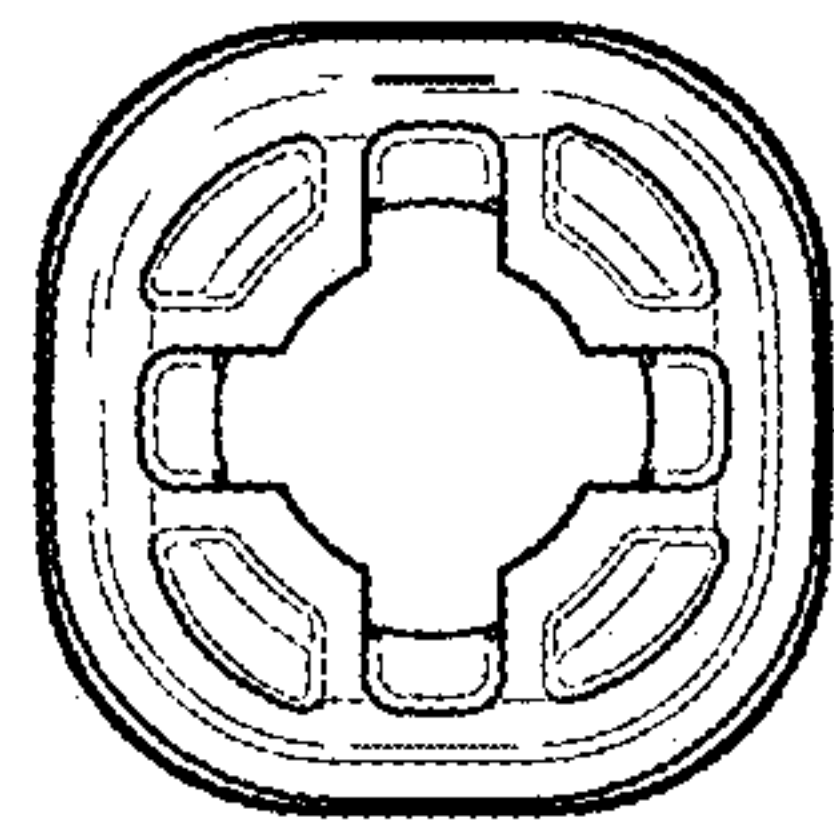

FIG. 16