



US00D951440S

(12) **United States Design Patent** (10) **Patent No.:** **US D951,440 S**  
**Tsubouchi et al.** (45) **Date of Patent:** **\*\* May 10, 2022**

(54) **SUCTION STABILIZER FOR MINIMALLY INVASIVE OFF-PUMP BYPASS SURGERY**

(74) *Attorney, Agent, or Firm* — Darryl Newell; MacMillan, Sobanski & Todd, LLC

(71) Applicant: **TERUMO CARIDOVASCULAR SYSTEMS CORPORATION**, Ann Arbor, MI (US)

(57) **CLAIM**

The ornamental design for a suction stabilizer for minimally invasive off-pump bypass surgery, as shown and described.

(72) Inventors: **Takeshi Tsubouchi**, Dexter, MI (US); **Eisuke Sasaki**, Bear, DE (US)

**DESCRIPTION**

(73) Assignee: **Terumo Cardiovascular Systems Corporation**, Ann Arbor, MI (US)

FIG. 1 is a top perspective view of a suction stabilizer for minimally invasive off-pump bypass surgery embodying our design with a bendable shaft at a first orientation.

(\*\*) Term: **15 Years**

FIG. 2 is a top plan view thereof with the bendable shaft at the first orientation.

(21) Appl. No.: **29/695,153**

FIG. 3 is a bottom plan view thereof with the bendable shaft at the first orientation.

(22) Filed: **Jun. 17, 2019**

FIG. 4 is a side elevational view thereof with the bendable shaft at the first orientation.

(51) **LOC (13) Cl.** ..... **24-02**

(52) **U.S. Cl.**  
USPC ..... **D24/133**

FIG. 5 is a side elevational view thereof with the bendable shaft at the first orientation.

(58) **Field of Classification Search**  
USPC ..... D24/133, 128, 135, 159, 183, 184, 190;  
D15/140, 199

FIG. 6 is a front elevational view thereof with the bendable shaft at the first orientation.

FIG. 7 is a rear elevational view thereof with the bendable shaft at the first orientation.

(Continued)

FIG. 8 is a bottom perspective view thereof with the bendable shaft at the first orientation.

(56) **References Cited**

**U.S. PATENT DOCUMENTS**

D364,681 S \* 11/1995 Livernois ..... D24/133  
5,846,193 A \* 12/1998 Wright ..... A61B 17/0206  
600/215

FIG. 9 is a side perspective view of a suction stabilizer for minimally invasive off-pump bypass surgery embodying our design with a bendable shaft at a second orientation.

FIG. 10 is a front elevational view thereof with the bendable shaft at the second orientation.

FIG. 11 is a rear elevational view thereof with the bendable shaft at the second orientation.

(Continued)

FIG. 12 is a side elevational view thereof with the bendable shaft at the second orientation.

**OTHER PUBLICATIONS**

Off-Pump Coronary Artery Bypass Grafting, [site visited Dec. 18, 2021]. Available from Internet. URL: [https://link.springer.com/chapter/10.1007/978-3-030-24174-2\\_16](https://link.springer.com/chapter/10.1007/978-3-030-24174-2_16) (Year: 2020).\*

FIG. 13 is a side elevational view thereof with the bendable shaft at the second orientation.

FIG. 14 is a top view thereof with the bendable shaft at the second orientation.

FIG. 15 is a bottom view thereof with the bendable shaft at the second orientation; and,

*Primary Examiner* — T Chase Nelson

*Assistant Examiner* — Kelly L Gross

(Continued)

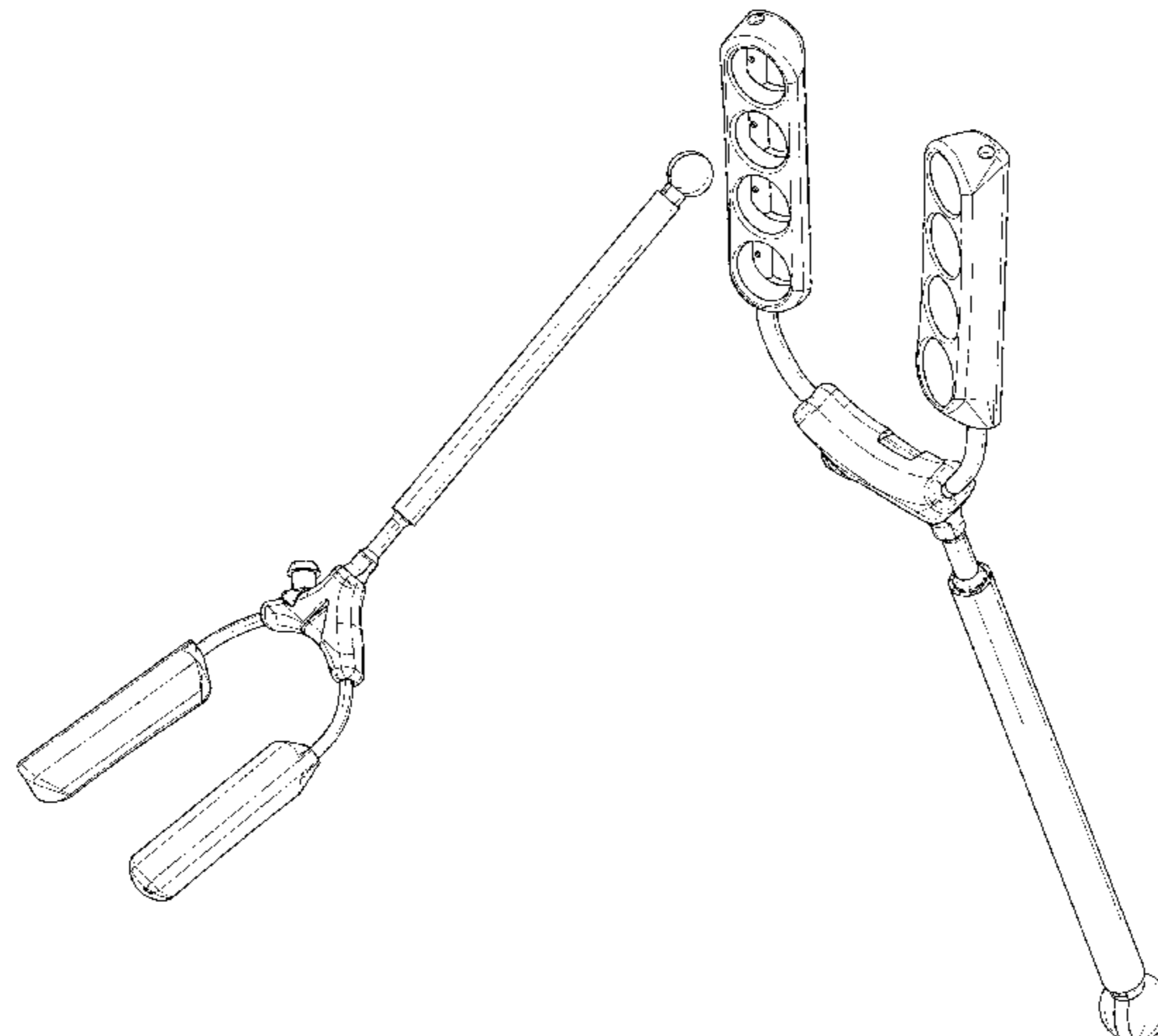

FIG. 16 is a bottom perspective view thereof with the bendable shaft at the second orientation.

**1 Claim, 14 Drawing Sheets**

**(58) Field of Classification Search**

CPC ..... A61B 2017/0287  
See application file for complete search history.

**(56) References Cited**

U.S. PATENT DOCUMENTS

5,891,017 A \* 4/1999 Swindle ..... A61B 17/0218  
600/205  
D411,299 S \* 6/1999 Farascioni ..... D24/135  
5,976,080 A \* 11/1999 Farascioni ..... A61B 17/0293  
600/201  
6,007,523 A \* 12/1999 Mangosong ..... A61M 25/0082  
604/284  
6,013,027 A \* 1/2000 Khan ..... A61B 17/02  
600/201  
D421,803 S \* 3/2000 Koros ..... D24/135  
6,036,641 A \* 3/2000 Taylor ..... A61B 17/00234  
600/231  
6,063,021 A \* 5/2000 Hossain ..... A61B 17/0218  
600/37  
6,152,874 A \* 11/2000 Looney ..... A61B 17/0206  
600/214  
D439,976 S \* 4/2001 Cote ..... D24/133  
6,210,323 B1 \* 4/2001 Gilhuly ..... A61B 17/02  
600/208  
6,231,506 B1 \* 5/2001 Hu ..... A61B 17/0206  
600/210  
6,290,644 B1 \* 9/2001 Green, II ..... A61B 17/00234  
600/209  
6,348,036 B1 \* 2/2002 Looney ..... A61B 17/0206  
600/232  
6,383,134 B1 \* 5/2002 Santilli ..... A61B 17/0206  
600/205  
6,394,951 B1 \* 5/2002 Taylor ..... A61B 17/00234  
600/210  
6,406,424 B1 \* 6/2002 Williamson, IV ..... A61B 1/32  
600/201  
6,464,629 B1 \* 10/2002 Boone ..... A61B 17/02  
600/37  
6,478,729 B1 \* 11/2002 Rogers ..... A61B 17/02  
128/898

6,511,416 B1 \* 1/2003 Green, II ..... A61B 17/02  
600/37  
6,685,632 B1 \* 2/2004 Hu ..... A61B 17/0206  
600/231  
6,740,029 B2 \* 5/2004 Rogers ..... A61B 17/02  
600/37  
6,849,075 B2 \* 2/2005 Bertolero ..... A61B 1/12  
128/898  
6,936,001 B1 \* 8/2005 Snow ..... A61B 17/02  
600/201  
7,018,328 B2 \* 3/2006 Mager ..... A61B 17/02  
600/37  
D525,708 S \* 7/2006 Jones ..... D24/155  
D576,277 S 9/2008 Oren et al.  
7,682,305 B2 3/2010 Bertolero et al.  
D624,647 S \* 9/2010 Dionisi ..... D24/133  
7,931,590 B2 \* 4/2011 Willis ..... A61B 17/0218  
600/219  
D638,938 S \* 5/2011 Doll ..... D24/140  
D642,679 S \* 8/2011 Raven, III ..... D24/135  
8,083,664 B2 \* 12/2011 Davis ..... A61B 17/0218  
600/37  
8,523,759 B2 9/2013 Bertolero et al.  
8,876,712 B2 \* 11/2014 Yee ..... A61B 17/0206  
600/231  
9,022,998 B2 \* 5/2015 Agarwal ..... A61M 13/003  
604/257  
D737,437 S \* 8/2015 McLoughlin ..... D24/135  
D738,176 S \* 9/2015 Rooney ..... D8/70  
D747,480 S \* 1/2016 Geebelen ..... D24/140  
D806,247 S \* 12/2017 Kheradpir ..... D24/147  
D820,984 S \* 6/2018 Kheradpir ..... D24/140  
D828,561 S \* 9/2018 Kheradpir ..... D24/147  
D833,011 S \* 11/2018 Nazarinasab ..... D24/147  
D838,848 S \* 1/2019 Neubauer ..... D24/158  
D838,849 S \* 1/2019 Neubauer ..... D24/158  
D838,850 S \* 1/2019 Neubauer ..... D24/158  
D842,989 S \* 3/2019 Theobald ..... D24/133  
D857,892 S \* 8/2019 Crawford ..... D24/140  
D860,446 S \* 9/2019 Crawford ..... D24/140  
D860,447 S \* 9/2019 Crawford ..... D24/140  
D860,448 S \* 9/2019 Crawford ..... D24/140  
10,405,980 B2 \* 9/2019 Morales ..... A61F 2/2481  
D865,172 S \* 10/2019 Crawford ..... D24/140  
D898,192 S \* 10/2020 Sauer ..... D24/133  
D898,909 S \* 10/2020 Sauer ..... D24/133  
D903,116 S \* 11/2020 Muyari ..... D24/146  
D920,507 S \* 5/2021 Sauer ..... D24/133  
D929,589 S \* 8/2021 Sweitzer ..... D24/142  
11,076,877 B2 \* 8/2021 Shelton, IV ..... A61B 17/2909  
D933,213 S \* 10/2021 Charbonneau ..... D24/133

\* cited by examiner

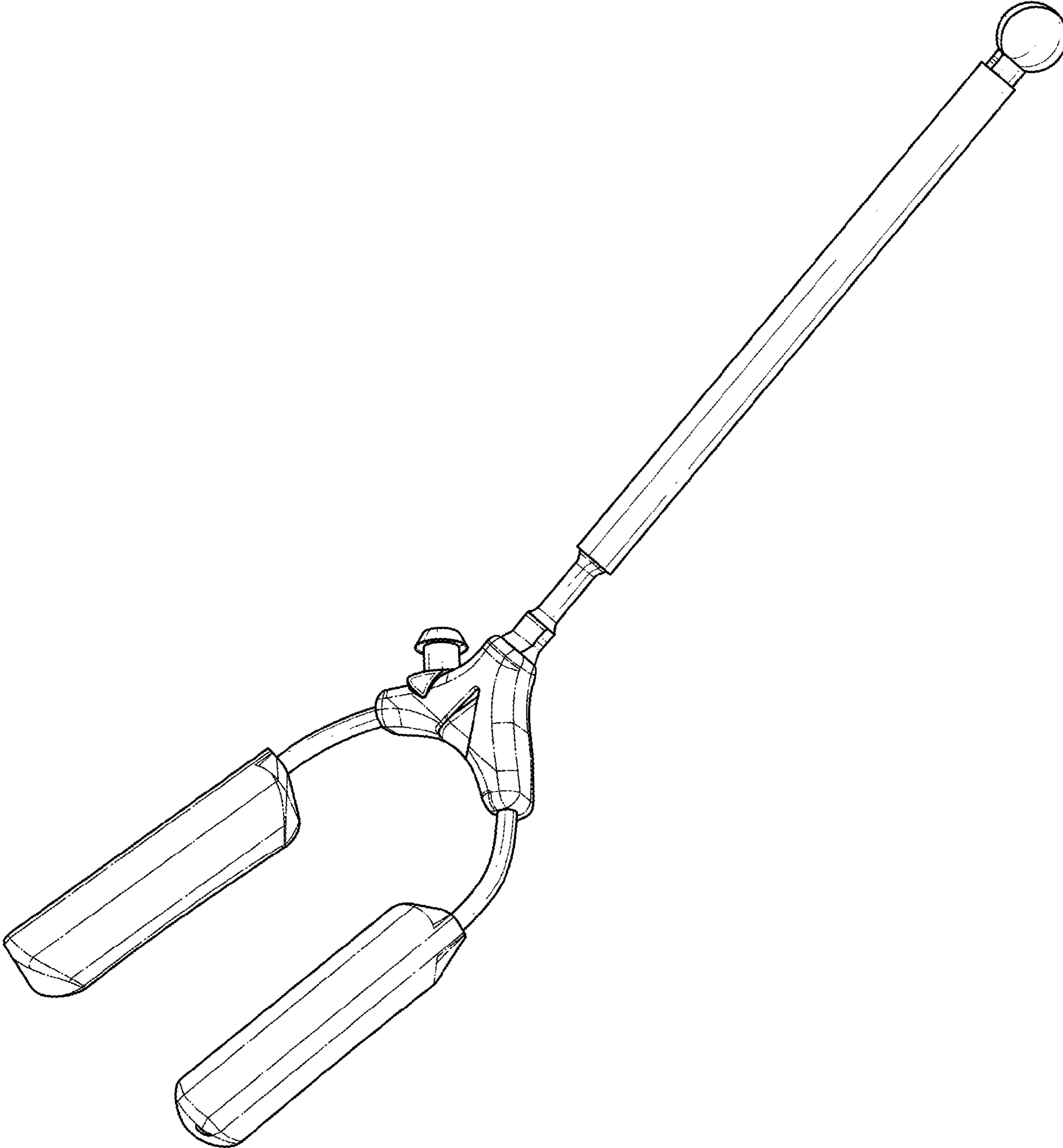

FIG. 1

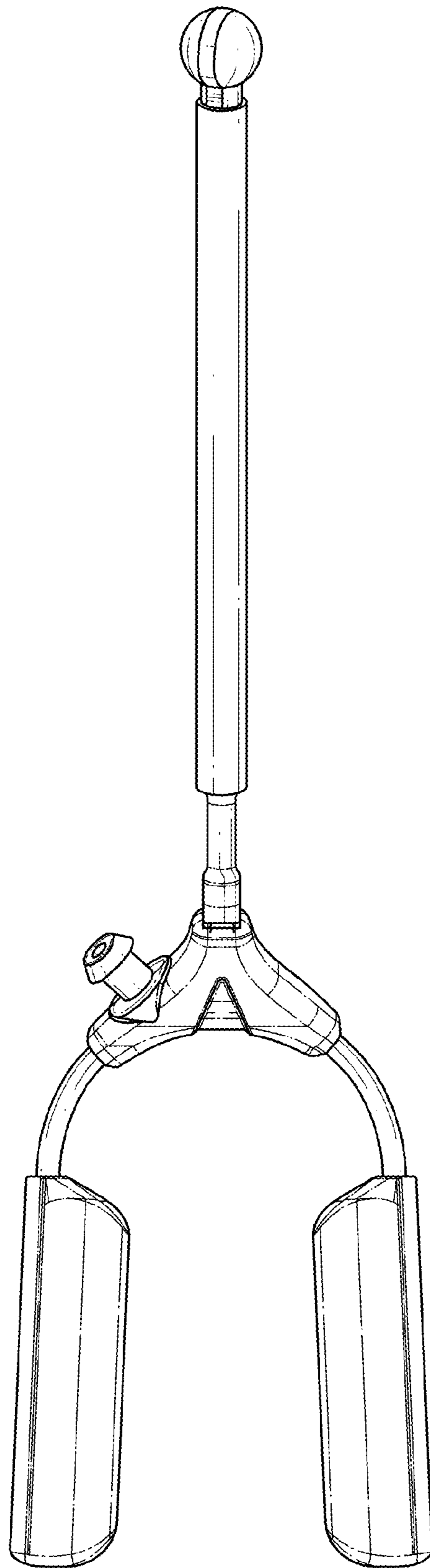

FIG. 2

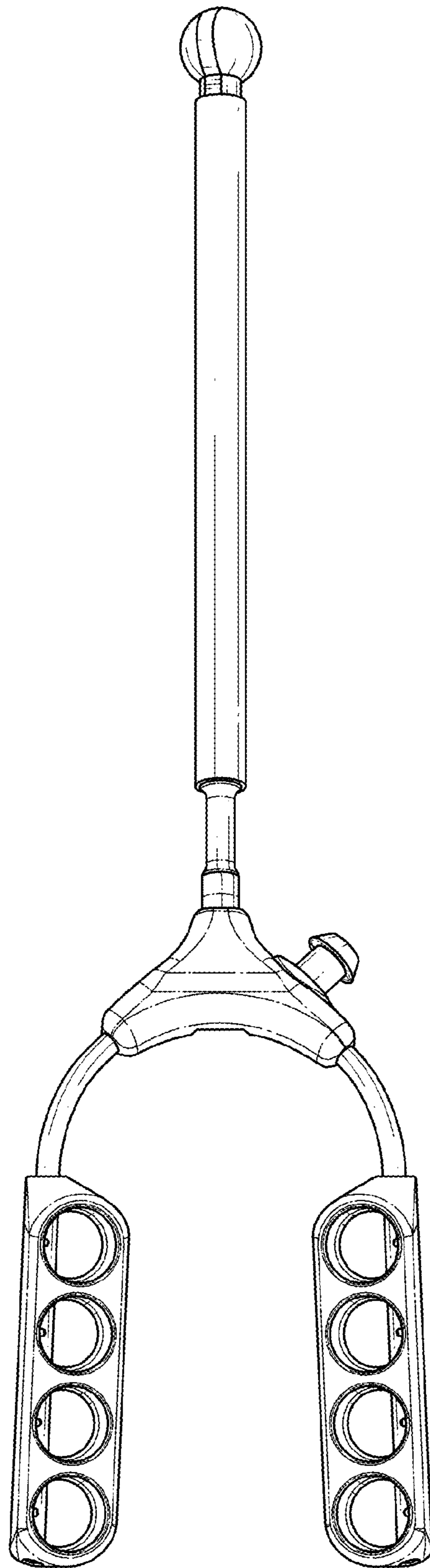

FIG. 3

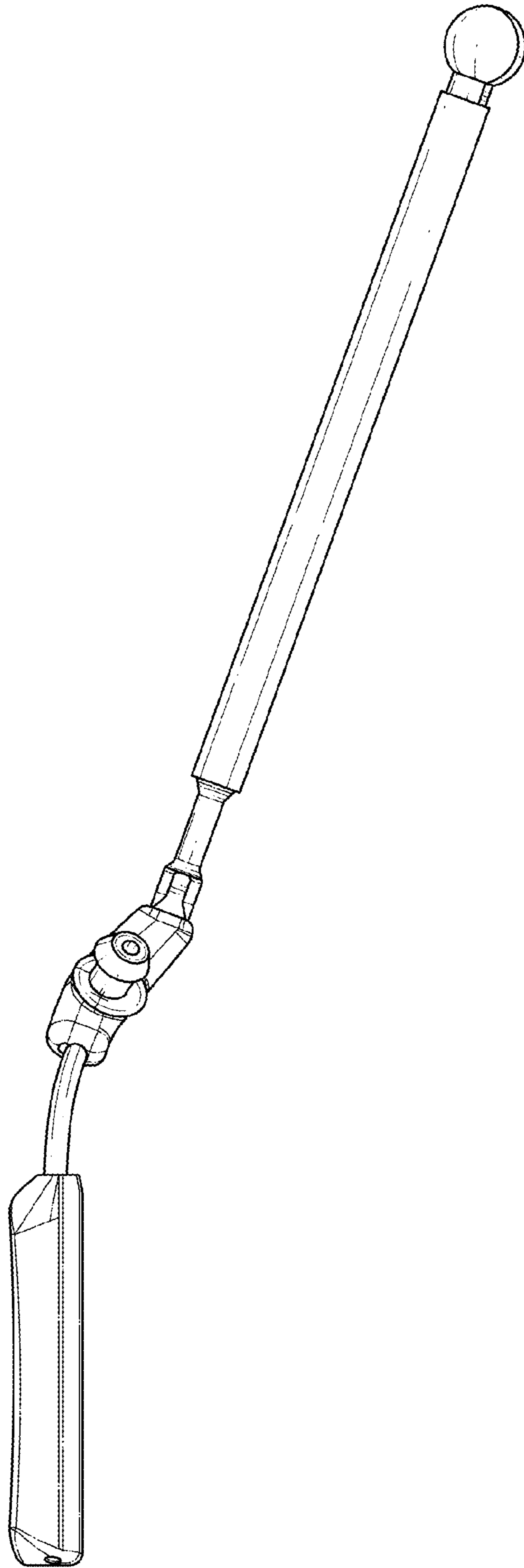

FIG. 4

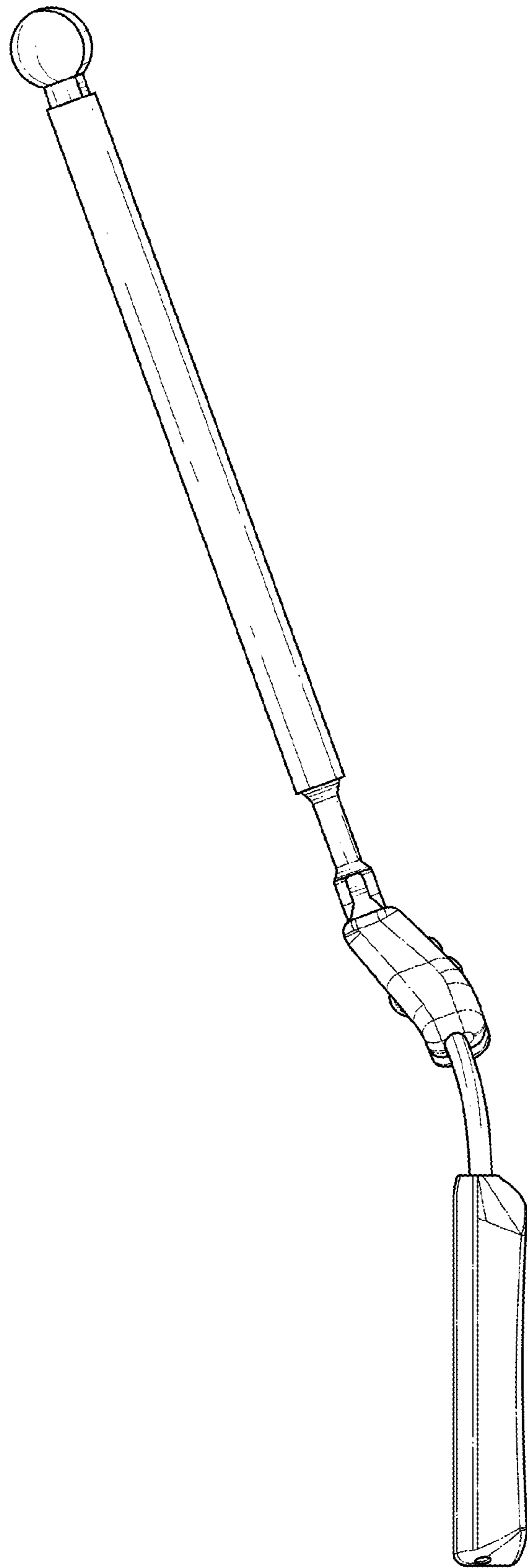

FIG. 5

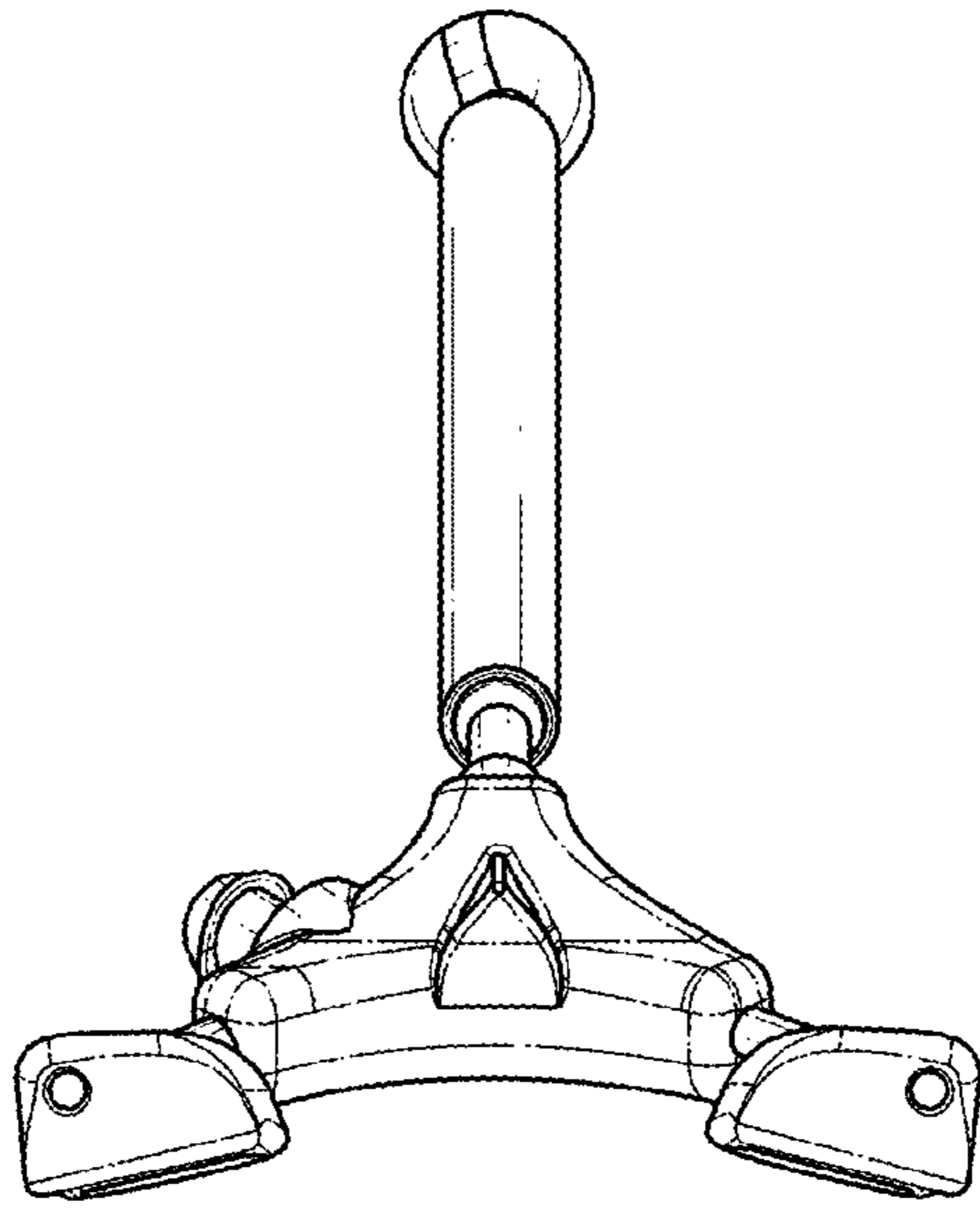

FIG. 6

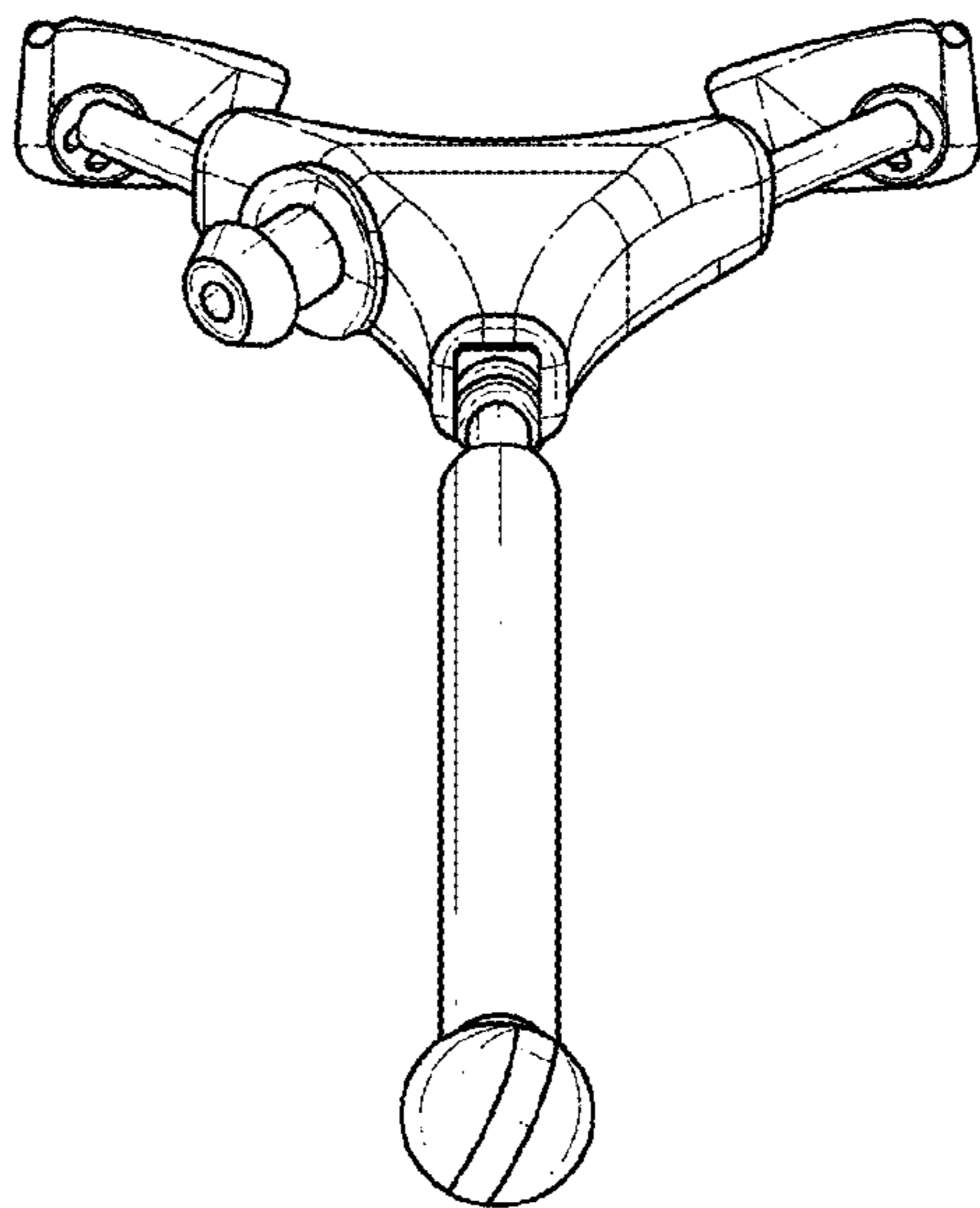

FIG. 7



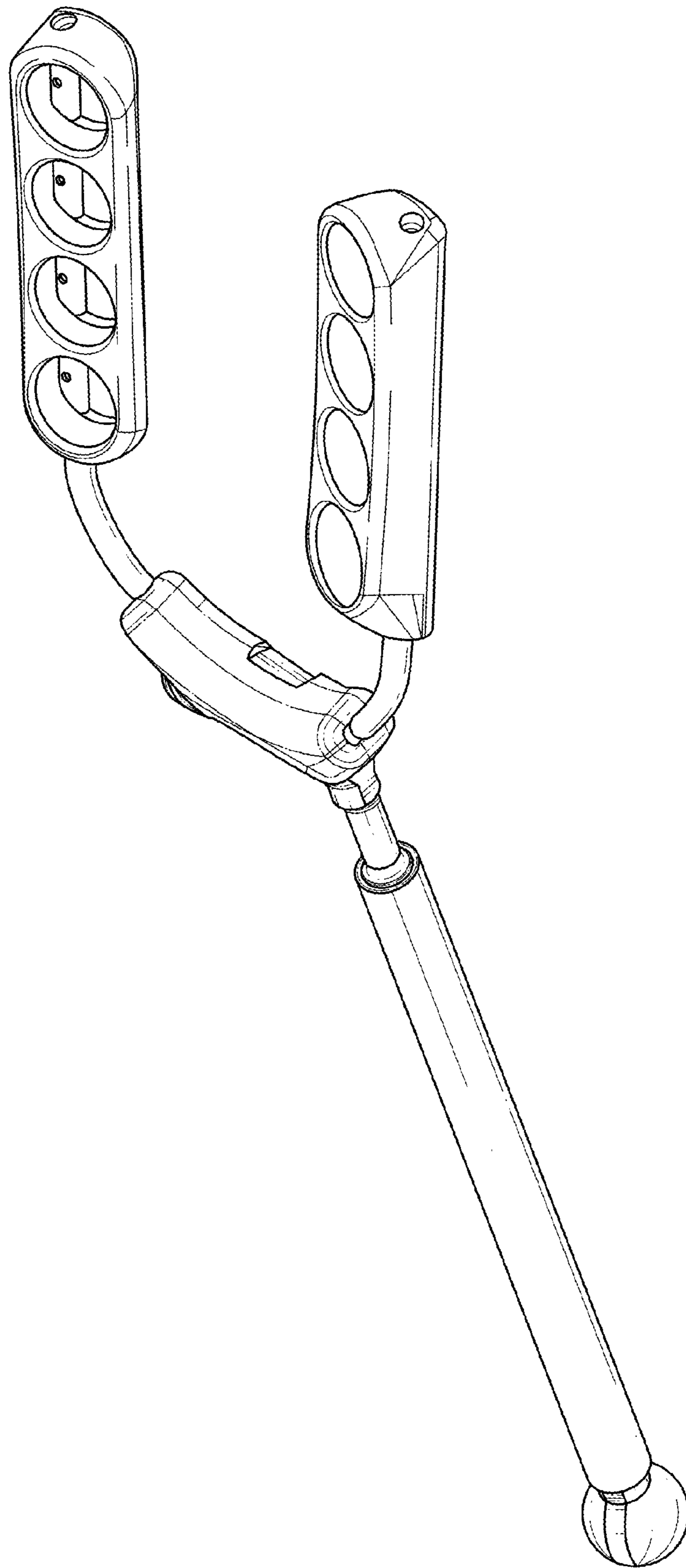

FIG. 8

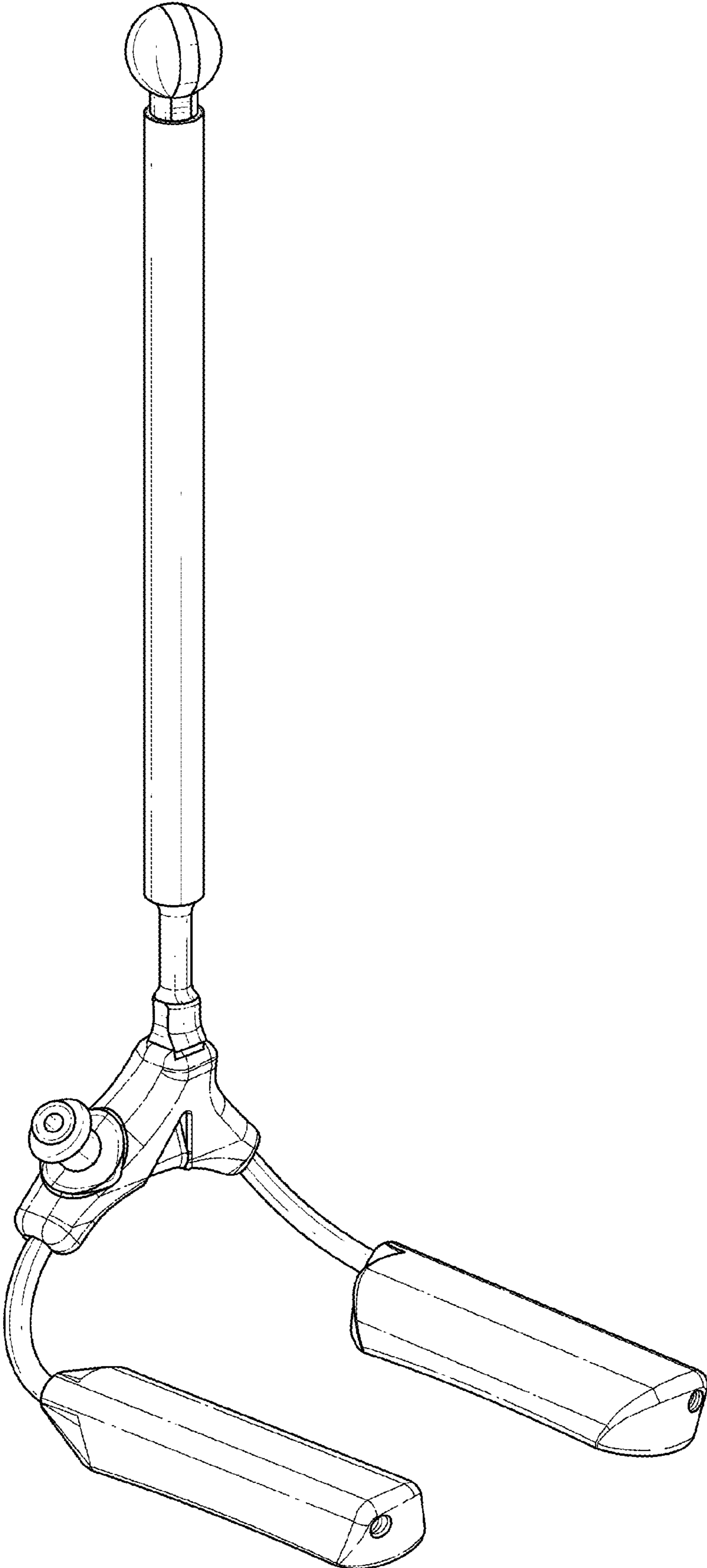

FIG. 9

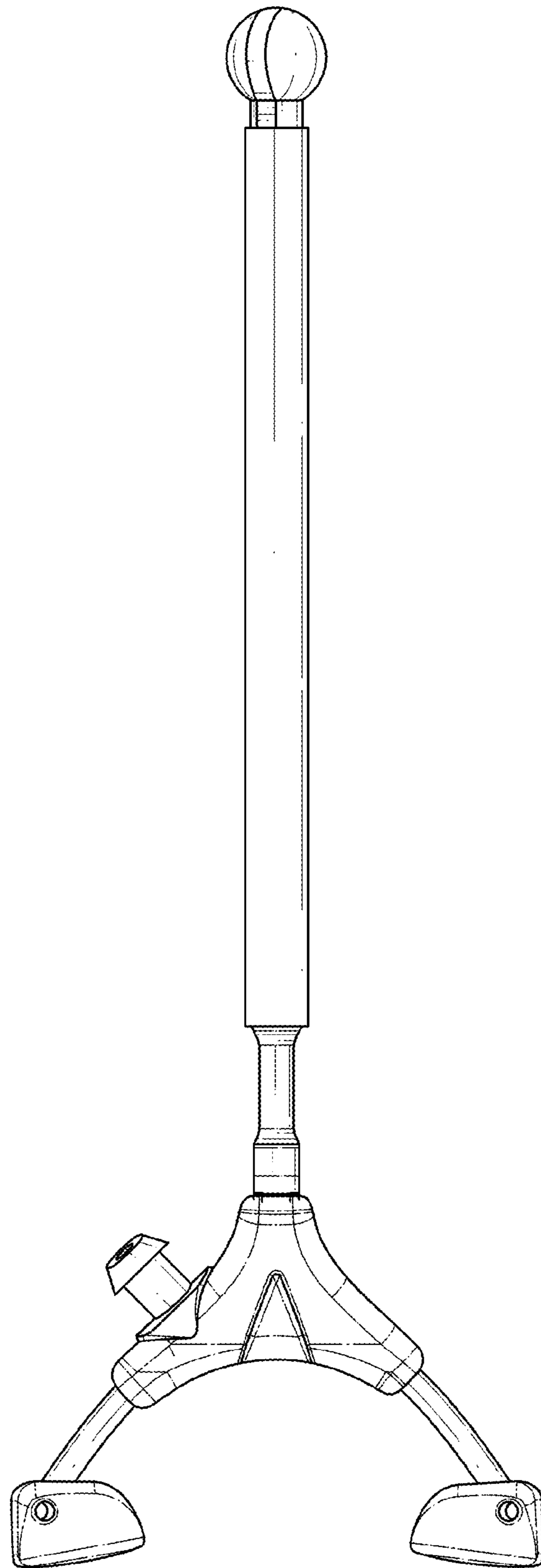

FIG. 10

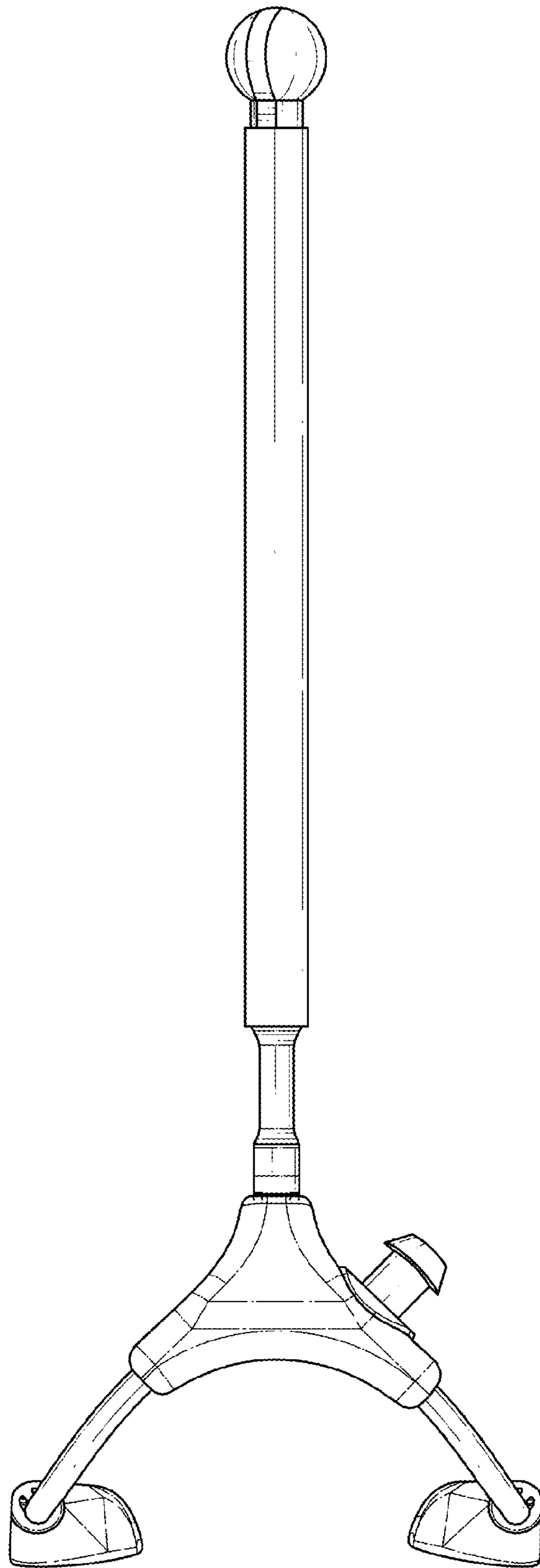

FIG. 11

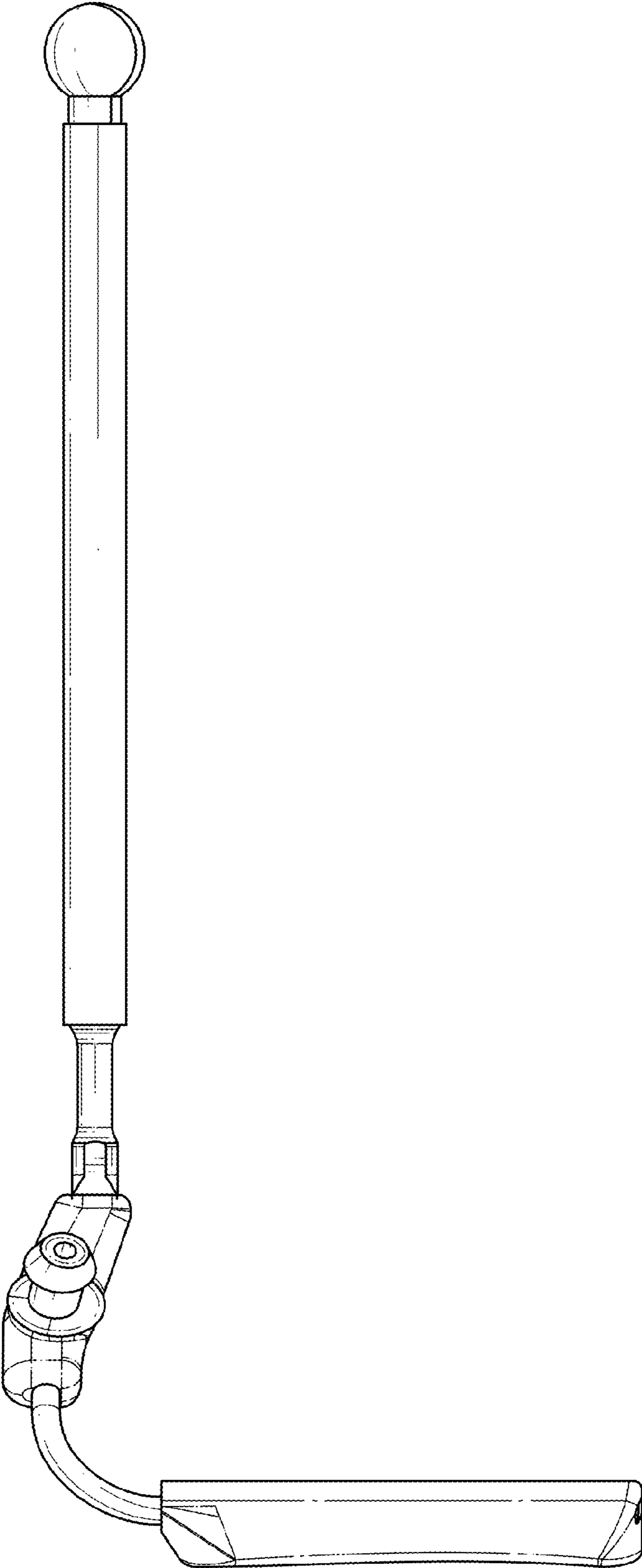

FIG. 12

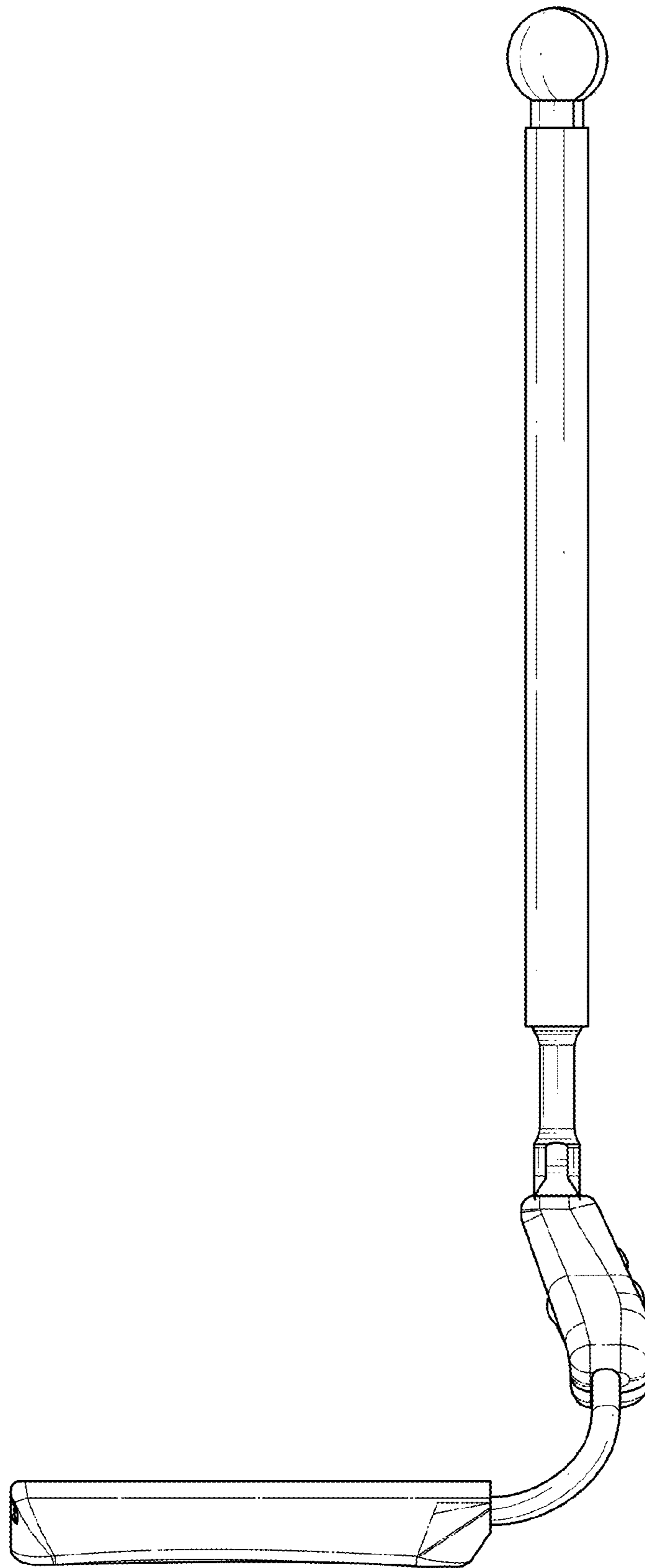

FIG. 13

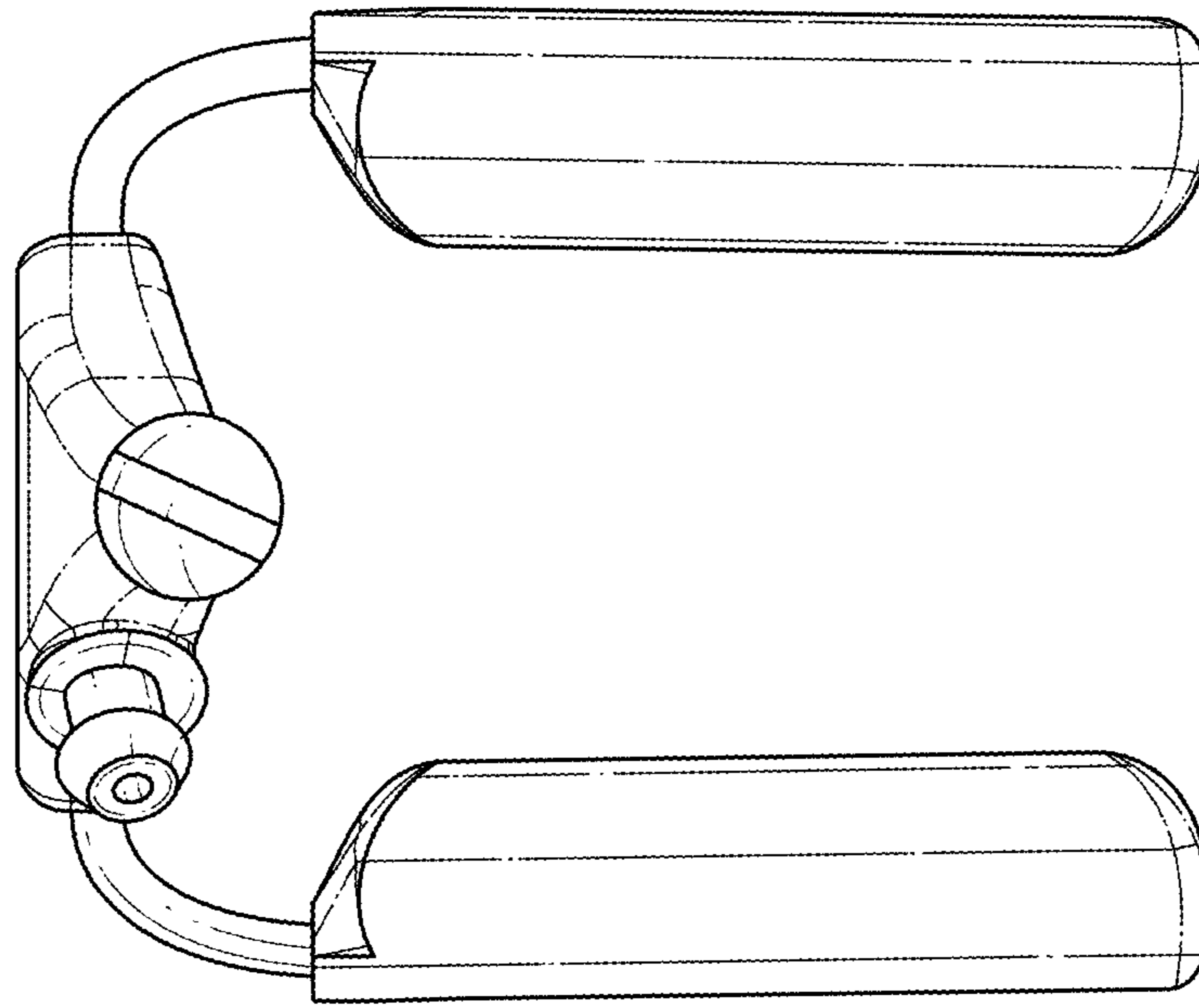

FIG. 14

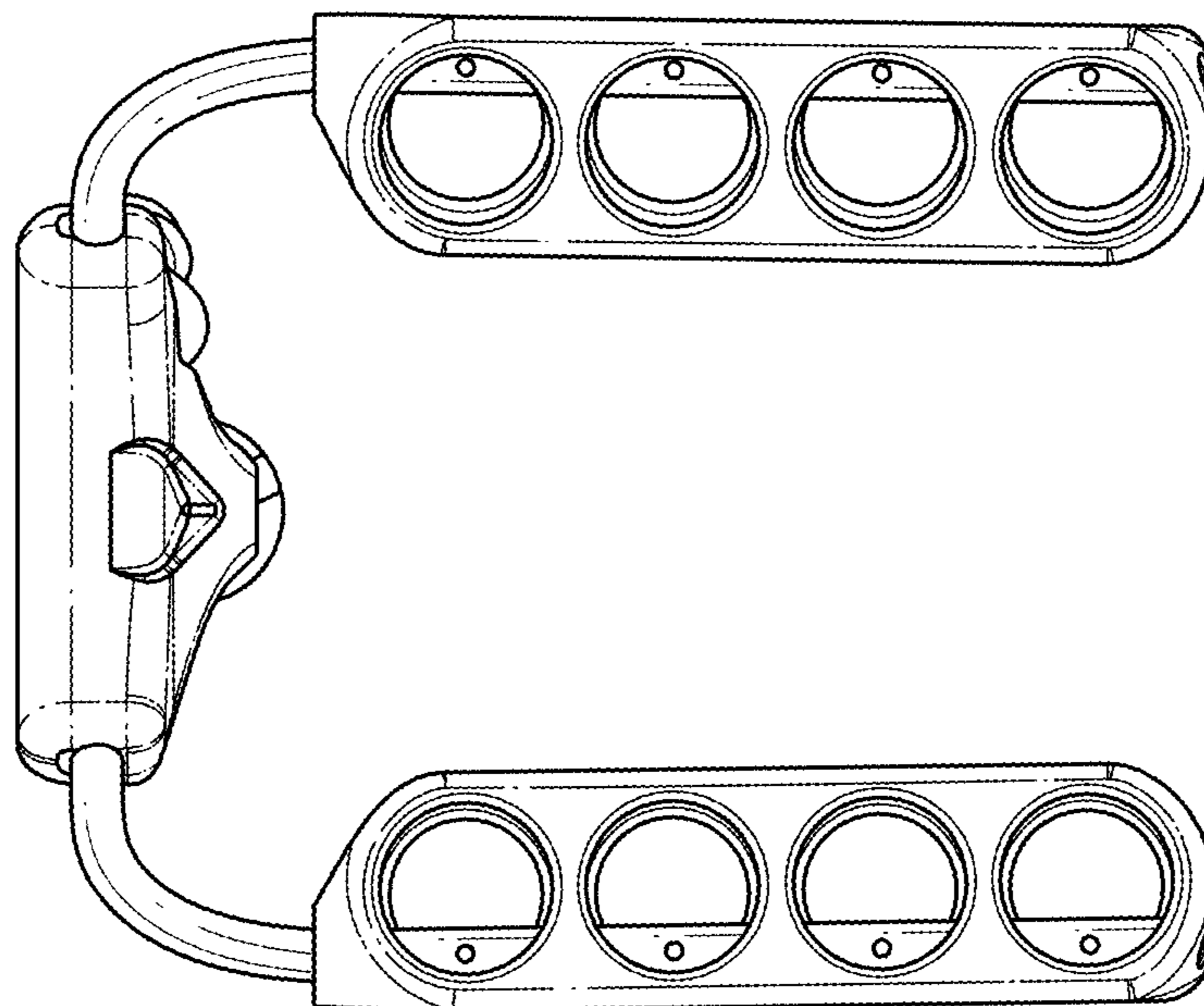

FIG. 15

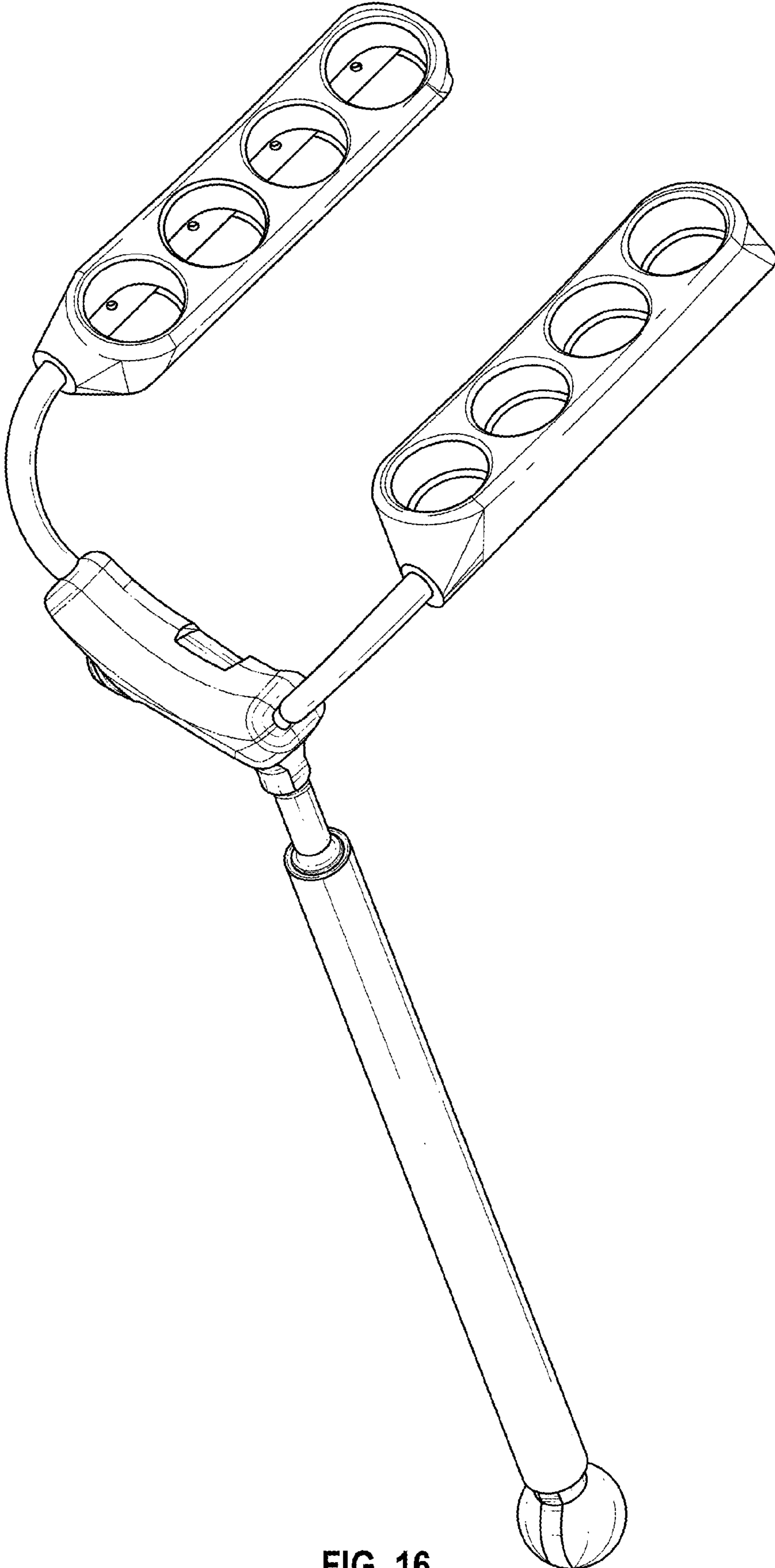

FIG. 16