



US00D951330S

(12) **United States Design Patent**  
**Nakamura**

(10) **Patent No.:** **US D951,330 S**

(45) **Date of Patent:** **\*\* May 10, 2022**

(54) **VEHICLE-MOUNTED CAMERA**

(71) Applicant: **Mitsubishi Electric Corporation,**  
Tokyo (JP)

(72) Inventor: **Mitsuo Nakamura,** Tokyo (JP)

(73) Assignee: **Mitsubishi Electric Corporation,**  
Tokyo (JP)

(\*\*) Term: **15 Years**

(21) Appl. No.: **29/730,309**

(22) Filed: **Apr. 2, 2020**

(30) **Foreign Application Priority Data**

Dec. 23, 2019 (JP) ..... 2019-028482

(51) **LOC (13) Cl.** ..... **16-05**

(52) **U.S. Cl.**  
USPC ..... **D16/219; D16/208**

(58) **Field of Classification Search**  
USPC ..... D16/200–208, 210, 214, 218, 219, 242;  
D12/187–189; 348/373–376; 396/419,  
396/427, 428, 535, 539–541  
CPC ..... G03B 15/03; G03B 17/02; G03B 17/04;  
G03B 17/56; G03B 19/04; H04N 5/2251;  
H04N 5/2252; H04N 5/2253; H04N  
5/2254; H04N 2101/00; B60R 1/12;  
B60R 19/28

See application file for complete search history.

(56) **References Cited**

**U.S. PATENT DOCUMENTS**

D744,573 S \* 12/2015 Matsumiya ..... D16/218  
9,319,639 B1 \* 4/2016 Englander ..... B60R 1/12

9,604,576 B2 *	3/2017	Uken	.....	B60R 19/28
D834,476 S *	11/2018	Tang	.....	D12/187
D834,633 S *	11/2018	Carlson	.....	D16/208
D848,508 S *	5/2019	Hsu	.....	D16/218
D852,253 S *	6/2019	Lee	.....	D16/200
D874,541 S *	2/2020	Kapuria	.....	D16/208
D875,811 S *	2/2020	Xiong	.....	D16/208
D890,241 S *	7/2020	Abdul	.....	D16/208
D907,098 S *	1/2021	Xiong	.....	D16/208
D922,470 S *	6/2021	Wang	.....	D16/208
D925,643 S *	7/2021	Hsu	.....	D16/218

\* cited by examiner

*Primary Examiner* — Ramzi Almatrahi

(74) *Attorney, Agent, or Firm* — Studebaker & Brackett  
PC

(57) **CLAIM**

The ornamental design for a vehicle-mounted camera, as shown and described.

**DESCRIPTION**

FIG. 1 is a front, top, and right side perspective view of a vehicle-mounted camera showing my new design;  
FIG. 2 is a rear, bottom, and left side perspective view thereof;  
FIG. 3 is a front view thereof;  
FIG. 4 is a rear view thereof;  
FIG. 5 is a top view thereof;  
FIG. 6 is a bottom view thereof;  
FIG. 7 is a right side view thereof; and,  
FIG. 8 is a left side view thereof.

The broken lines depict portions of the vehicle-mounted camera in which the design is embodied that form no part of the claimed design. The dash-dot lines denote the boundary of the claim and form no part of the claimed design.

**1 Claim, 8 Drawing Sheets**

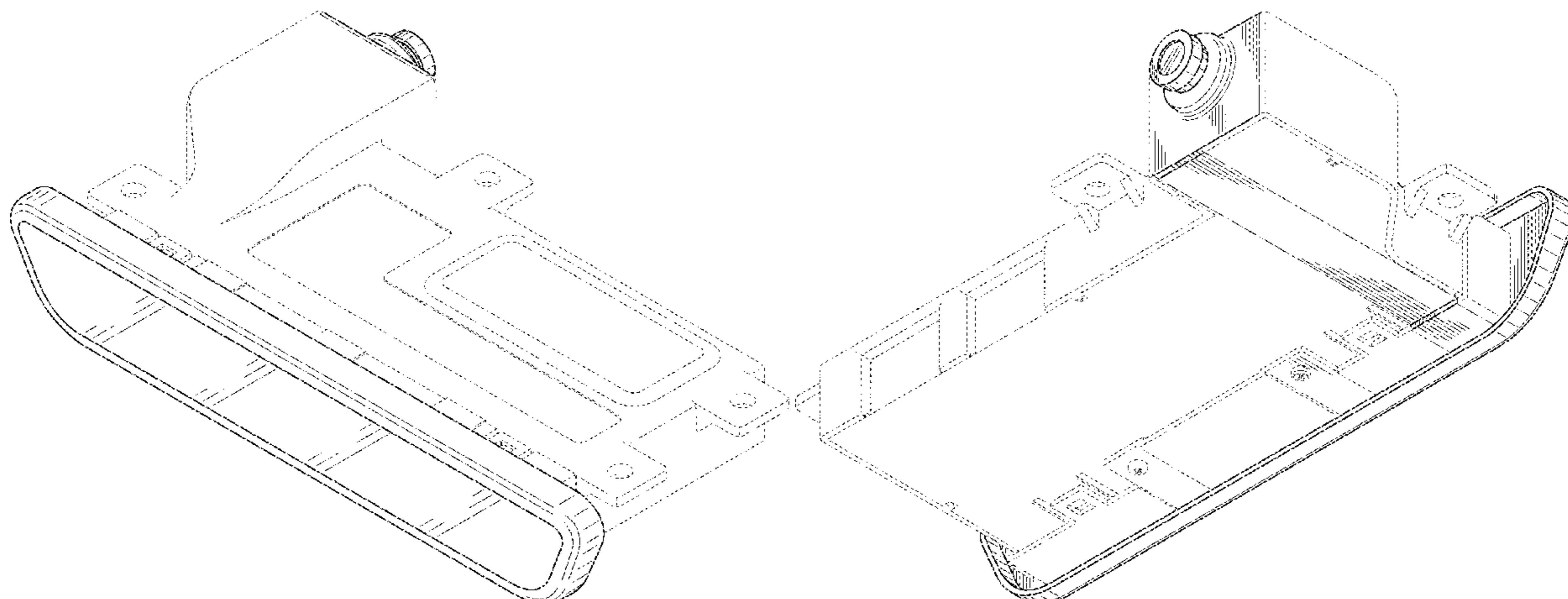

**FIG. 1**

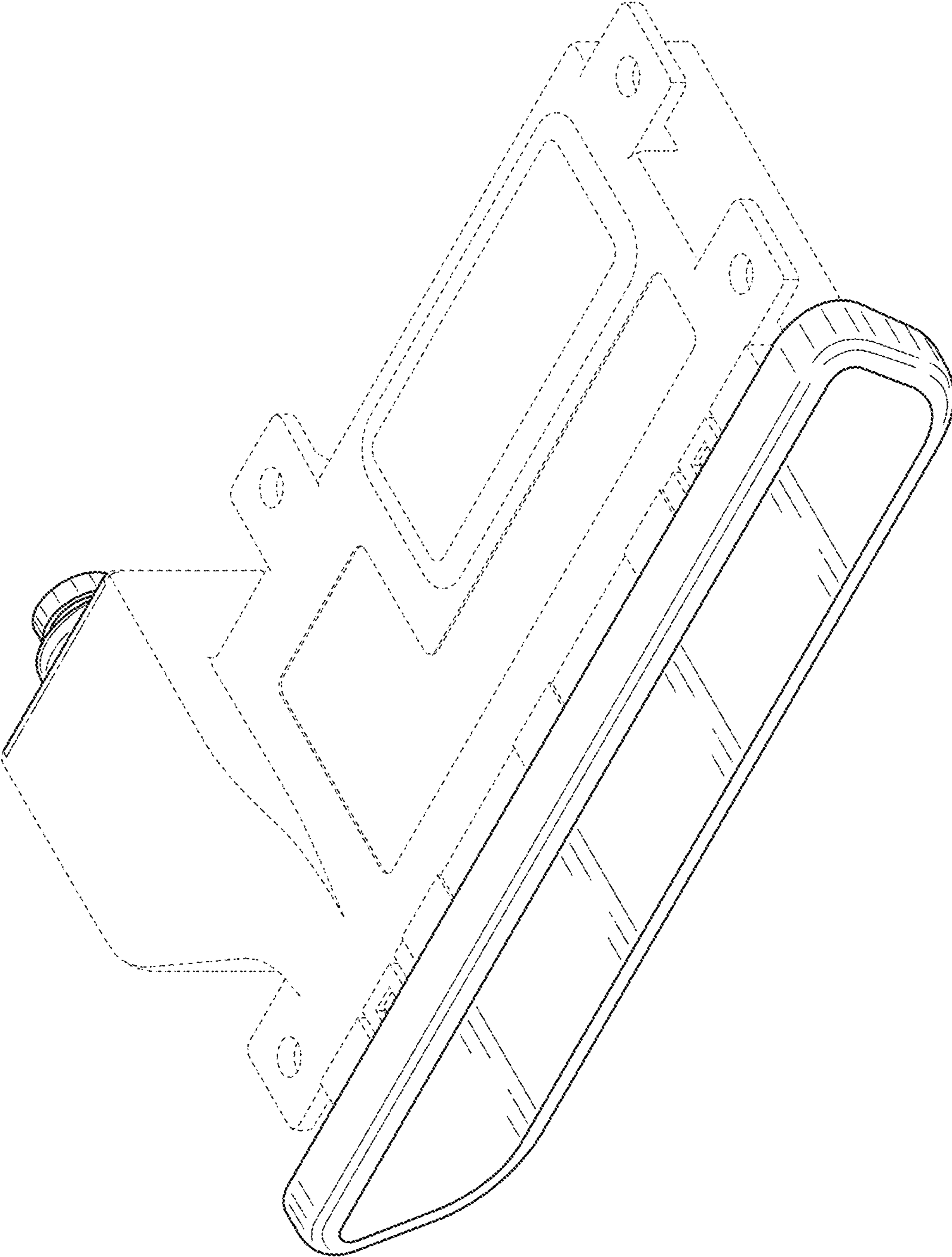

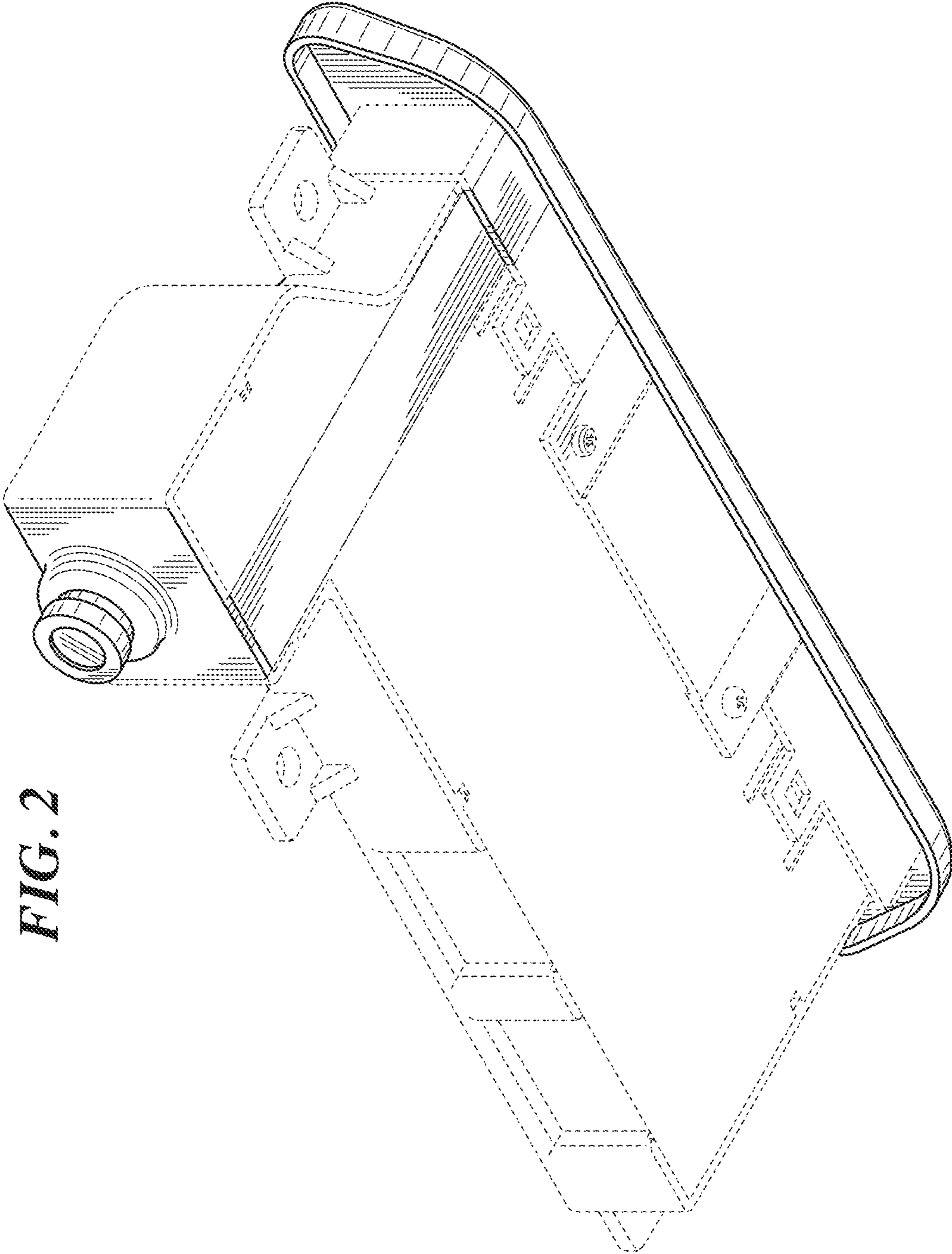
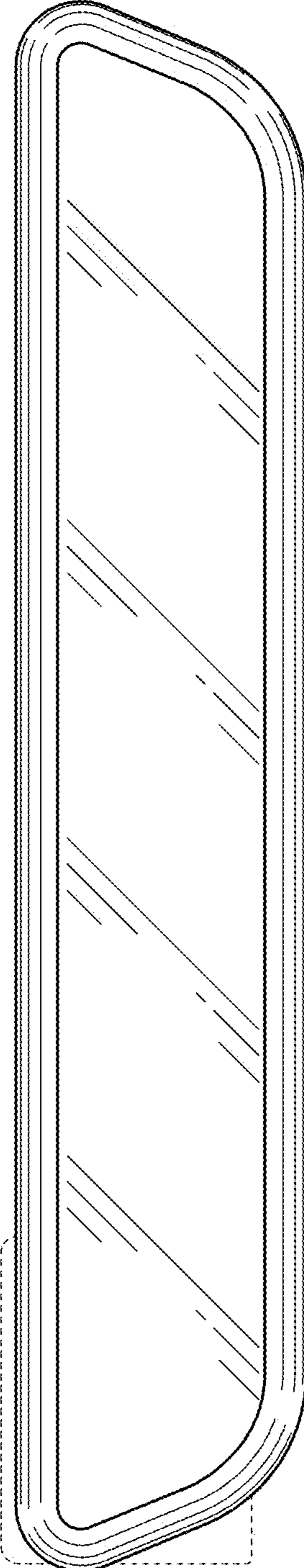
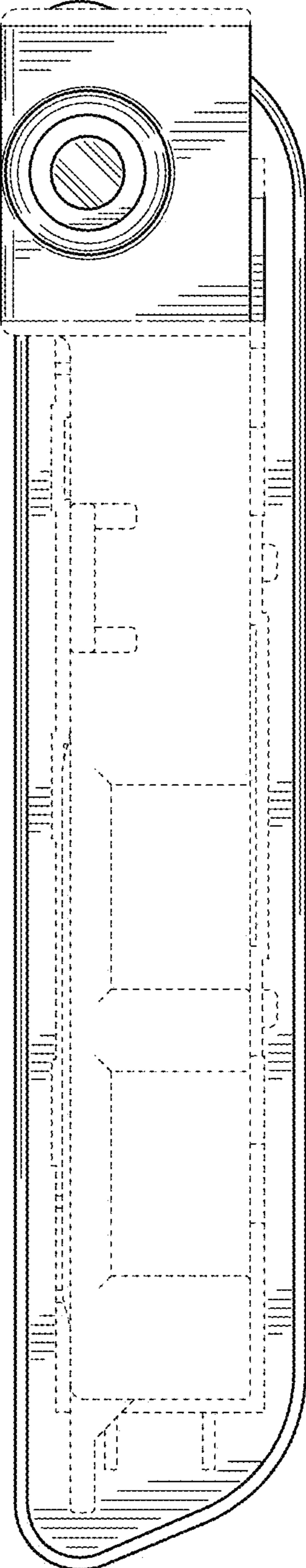

FIG. 2

**FIG. 3**



**FIG. 4**



**FIG. 5**

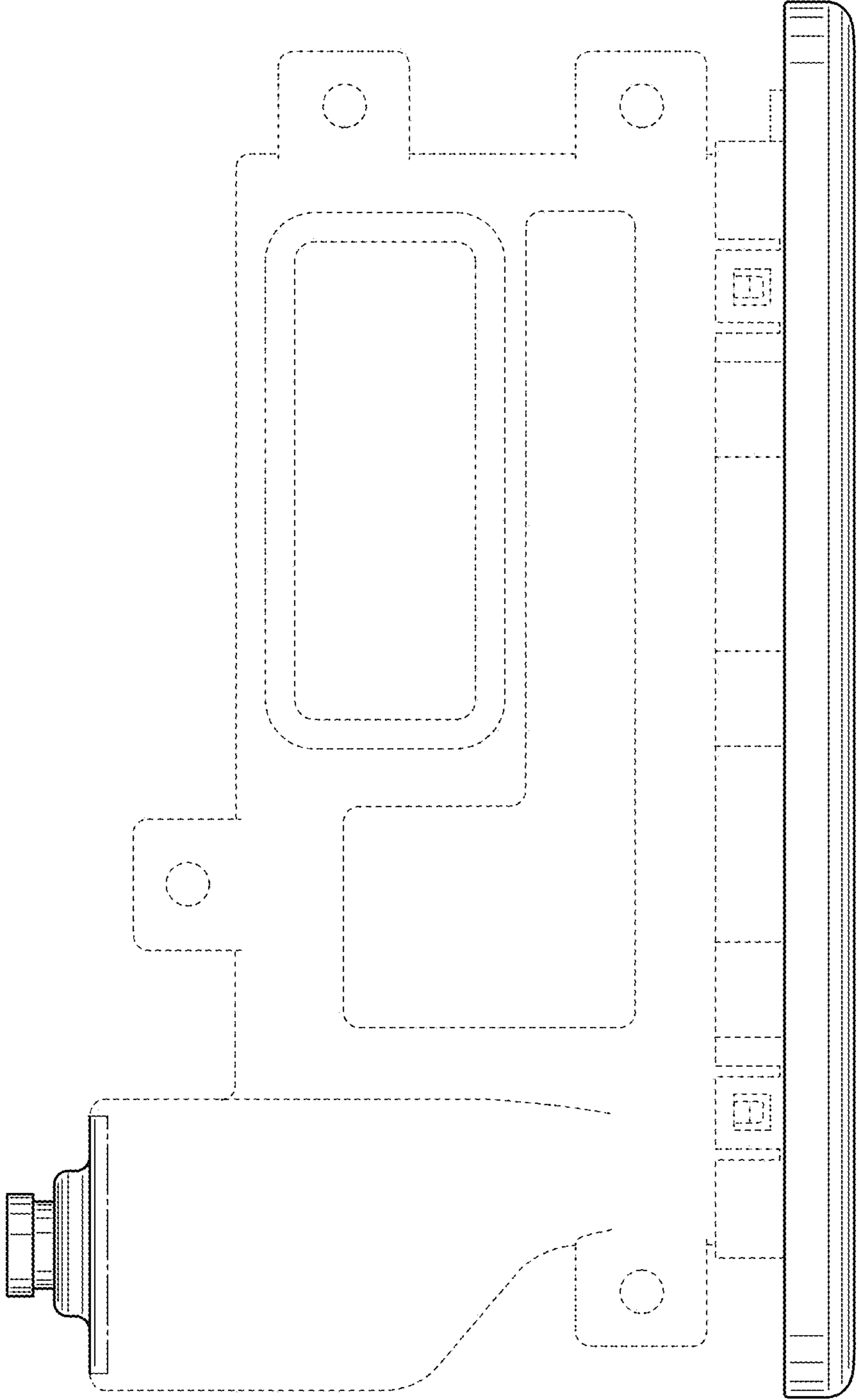

**FIG. 6**

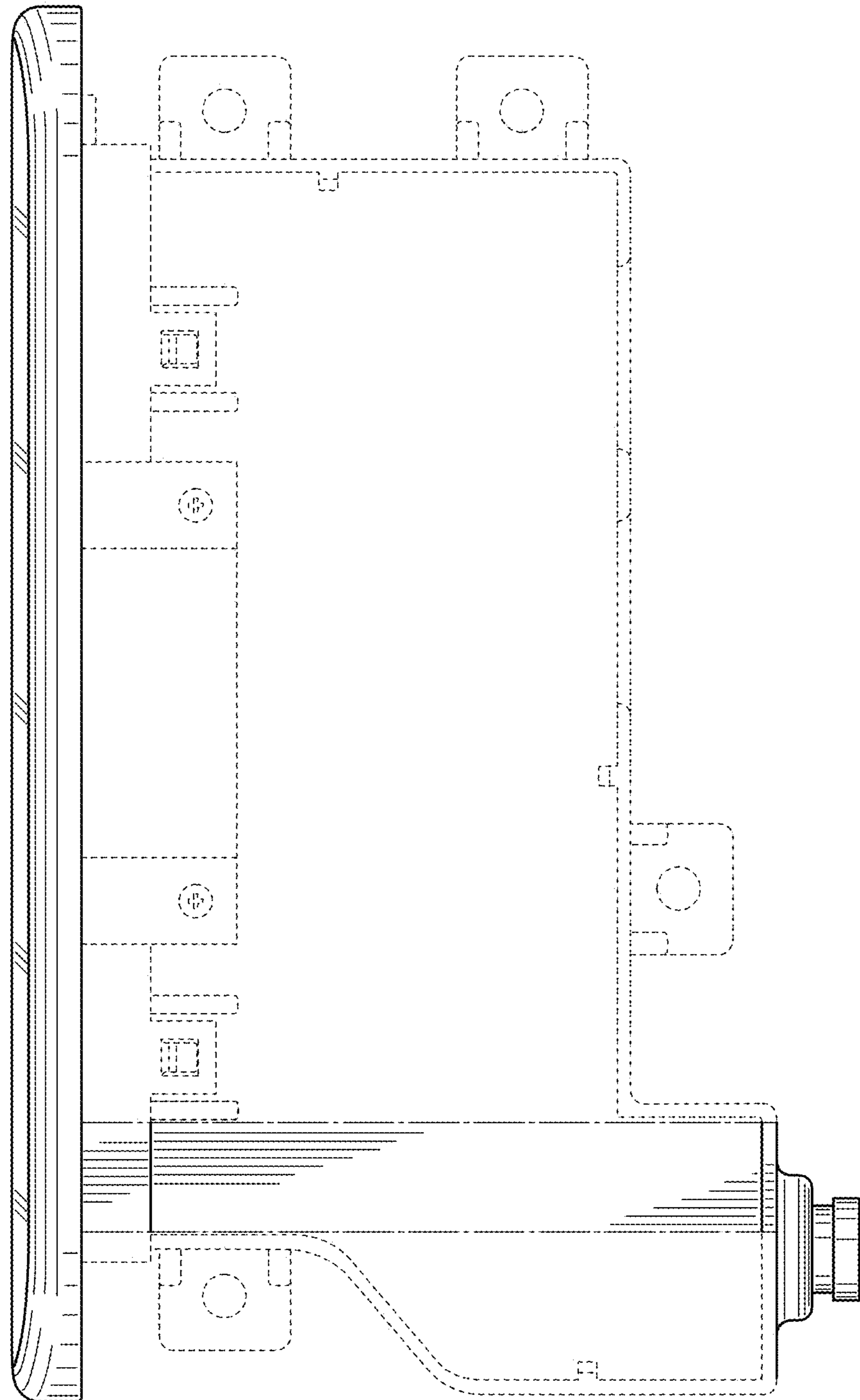

**FIG. 7**

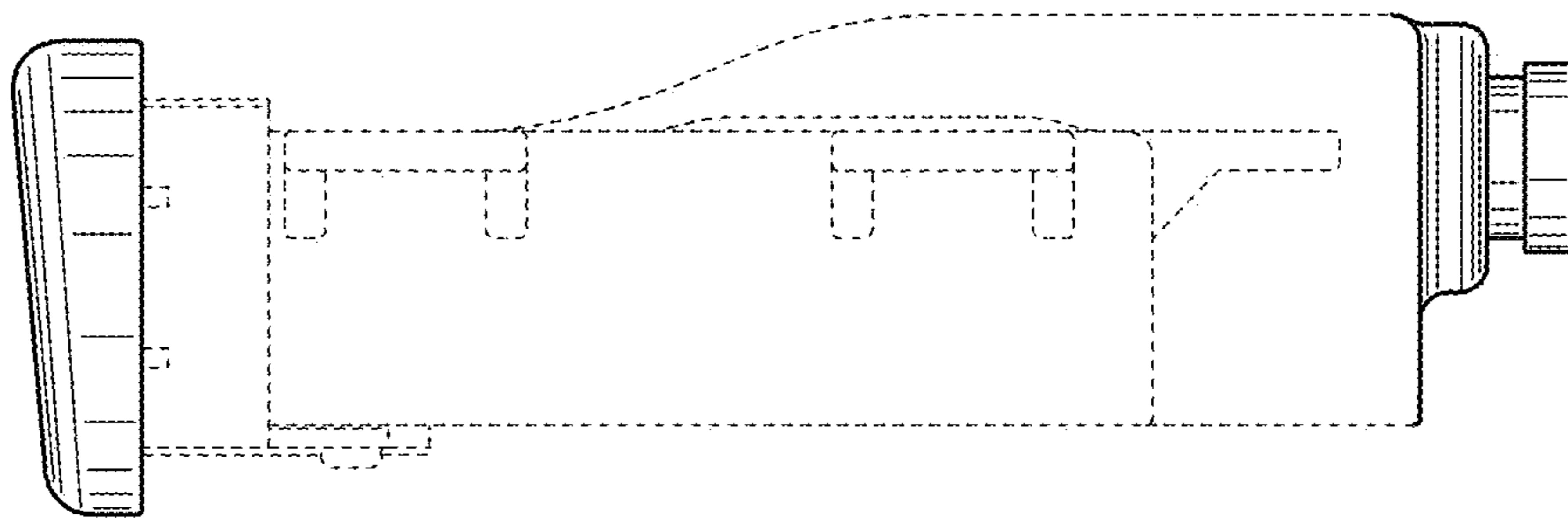



*FIG. 8*

