

US00D950607S

(12) **United States Design Patent**
Armstrong

(10) **Patent No.:** **US D950,607 S**

(45) **Date of Patent:** **** May 3, 2022**

(54) **AXIAL FLOW AIR/OIL SEPARATOR**

OTHER PUBLICATIONS

(71) Applicant: **Gary D. Armstrong**, Loomis, CA (US)

Armstrong Racing Engineering, Dry Sump Cast Oil Tank A-Series Tanks, (Site visited Sep. 9, 2021), Drysump.com website, URL:<https://www.drysump.com/index.php/oil-tanks-vent-cans/are-new-cast-tank> (Year: 2021).*

(72) Inventor: **Gary D. Armstrong**, Loomis, CA (US)

Ruein, Ruien Polish Baffled Universal Aluminum Oil Catch Can Reservoir Tank Black, (first available date Mar. 12, 2017), Amazon.com, URL:<https://www.amazon.com/Ruien-0046-Universal-Aluminum-Reservoir/dp/B06XK9PTP7> (Year: 2017).*

(**) Term: **15 Years**

(21) Appl. No.: **29/751,239**

* cited by examiner

(22) Filed: **Sep. 18, 2020**

(51) **LOC (13) Cl.** **15-01**

(52) **U.S. Cl.**

USPC **D15/5**

(58) **Field of Classification Search**

USPC D13/184; D15/1-7, 148, 150

CPC F01M 13/04; F01M 2013/0422; F01M

2013/0427; F01M 2013/0438; F01M

2013/0444; B01D 35/02; B04B 5/12;

F01L 1/047

See application file for complete search history.

Primary Examiner — Calvin E Vansant

Assistant Examiner — Mark T. Philipps

(74) *Attorney, Agent, or Firm* — Quickpatents, LLC;

Kevin Prince

(57) **CLAIM**

The ornamental design for an axial flow air/oil separator, as shown and described.

DESCRIPTION

(56) **References Cited**

U.S. PATENT DOCUMENTS

D215,882 S * 11/1969 Svenson D15/7

D244,681 S * 6/1977 Bell D15/7

5,277,154 A 1/1994 McDowell

7,445,653 B2 11/2008 Trautmann

D679,733 S * 4/2013 Armstrong D15/5

D715,841 S * 10/2014 Comben D15/143

D742,419 S * 11/2015 Armstrong D15/5

9,260,993 B1 2/2016 Mainiero

D796,554 S * 9/2017 Armstrong D15/5

D890,814 S * 7/2020 Armstrong D15/5

2008/0257161 A1 * 10/2008 Read B01D 46/2411

96/220

2012/0031276 A1 * 2/2012 Meusel F01L 1/047

96/400

2017/0320070 A1 * 11/2017 Bovensiep B04C 5/13

FIG. 1 is a perspective view of an axial flow air/oil separator, showing my new design;

FIG. 2 is a perspective view of FIG. 1 with the axial separator element removed and placed alongside the main body for clarity;

FIG. 3 is a front elevational view of FIG. 2;

FIG. 4 is a rear elevation view of FIG. 2;

FIG. 5 is a left-side elevation view of FIG. 2;

FIG. 6 is a right-side elevation view of FIG. 2;

FIG. 7 is a top plan view of FIG. 2; and,

FIG. 8 is a bottom plan view of FIG. 2.

The broken lines depict portions of the axial flow air/oil separator that form no part of the claimed design.

1 Claim, 6 Drawing Sheets

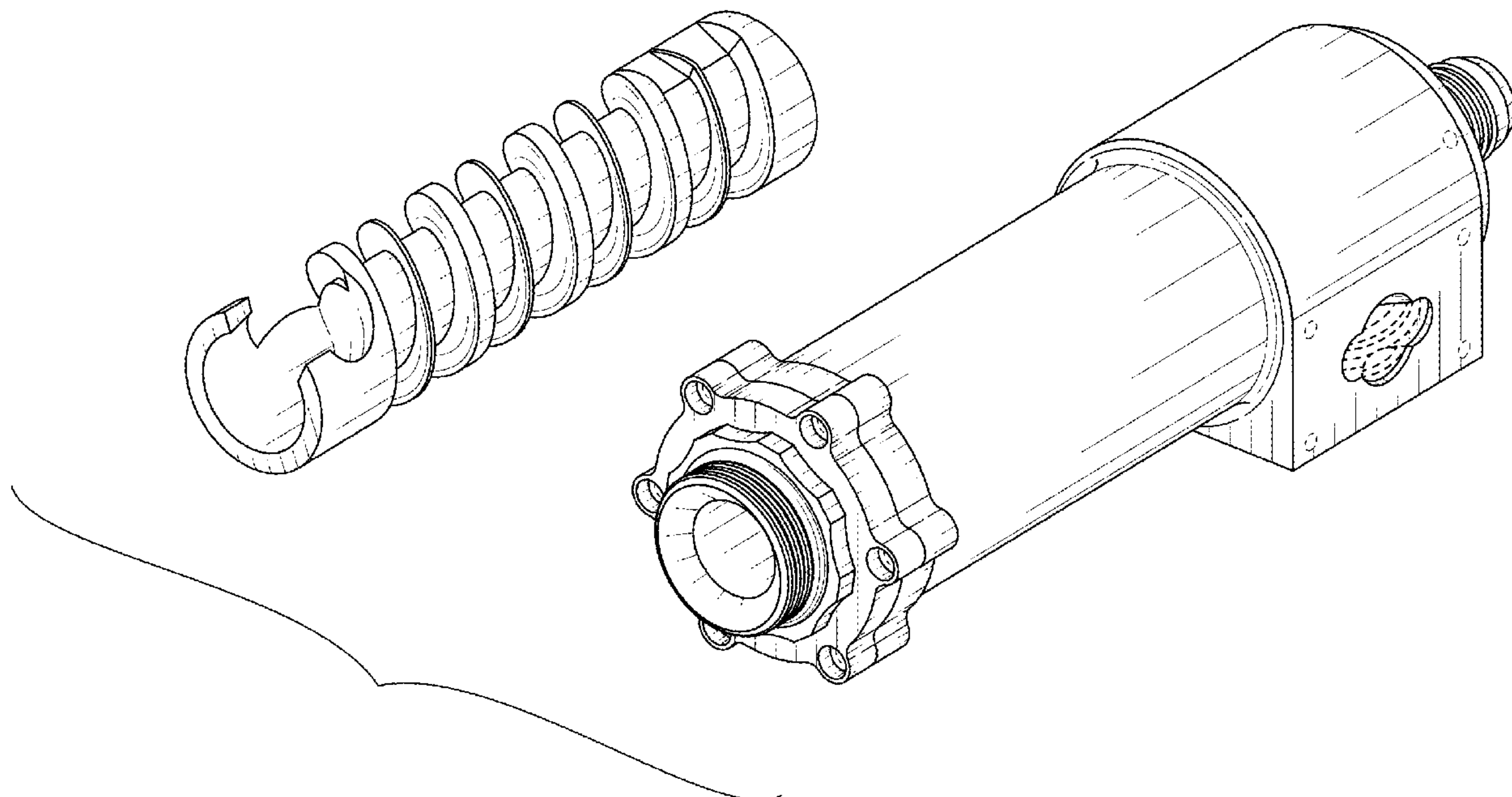

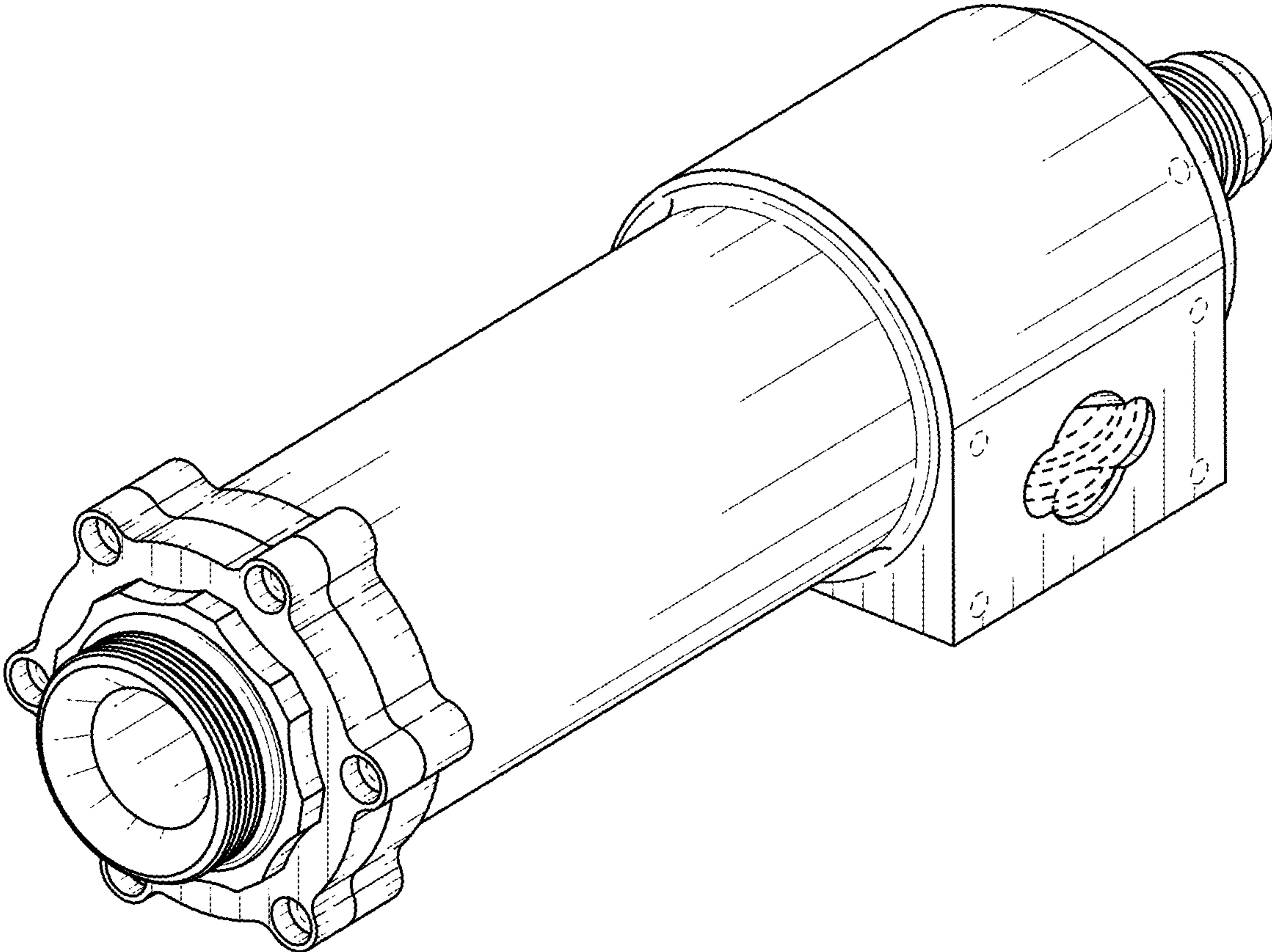

FIG. 1

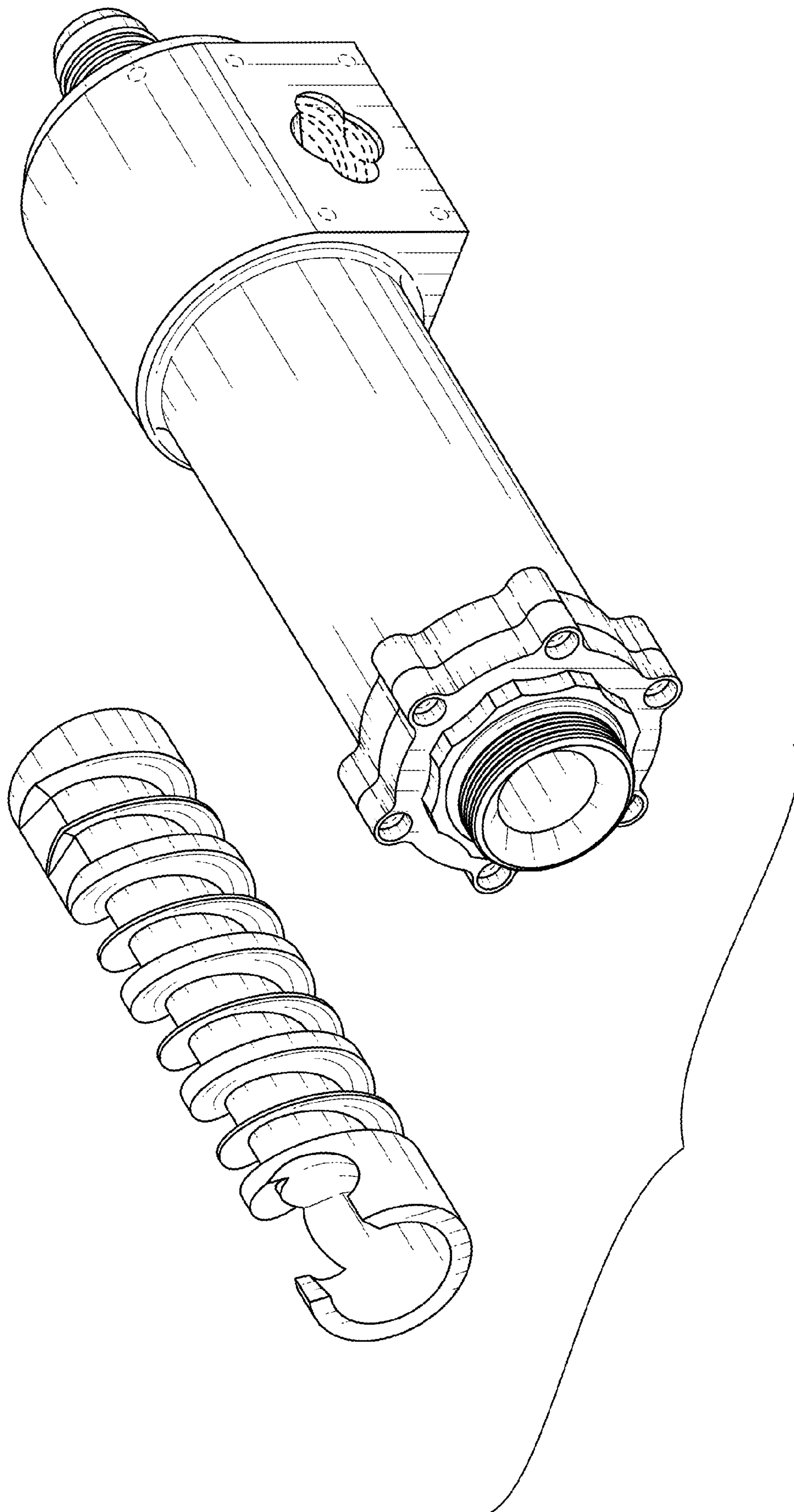

FIG. 2

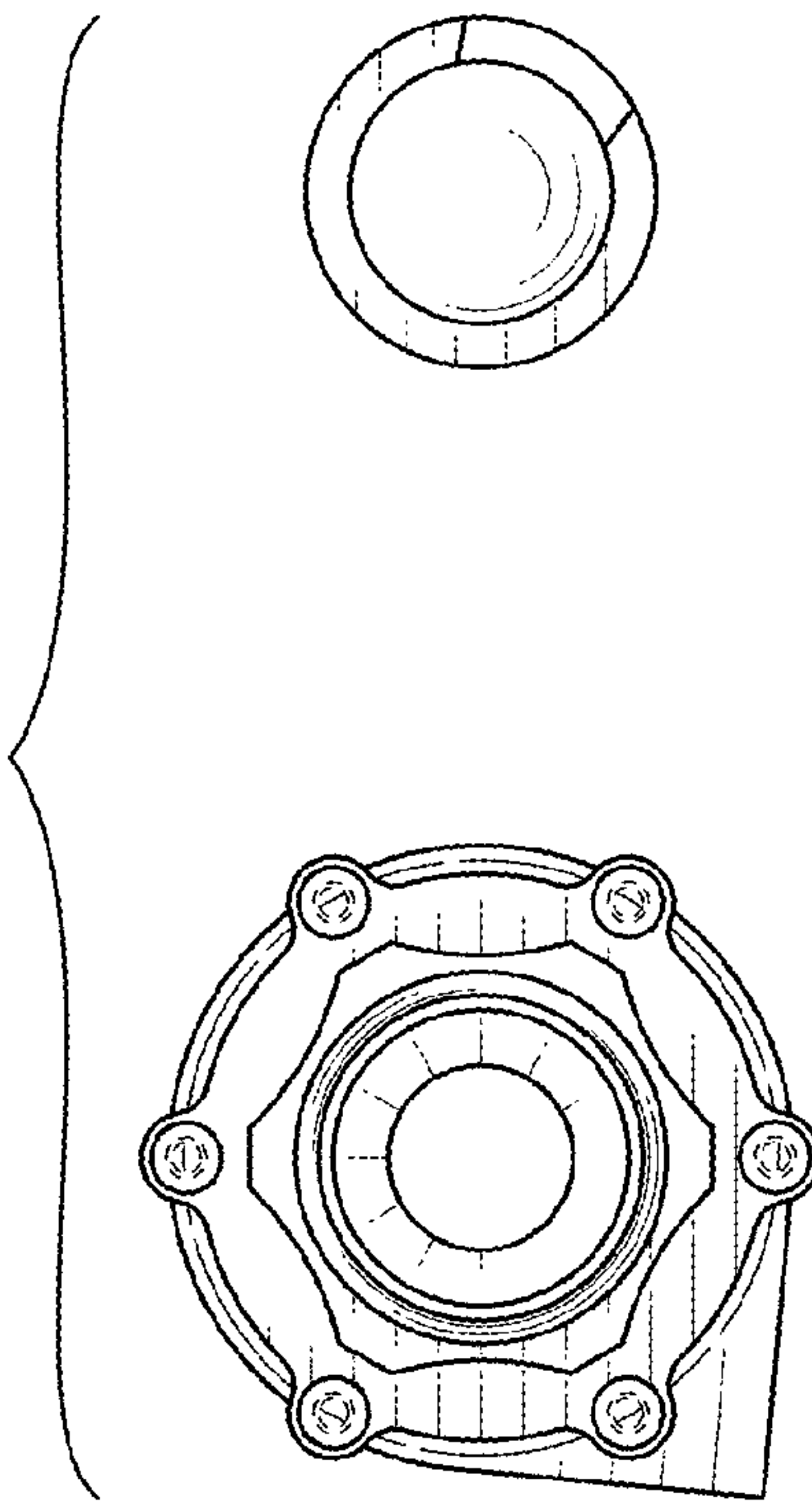

FIG. 3

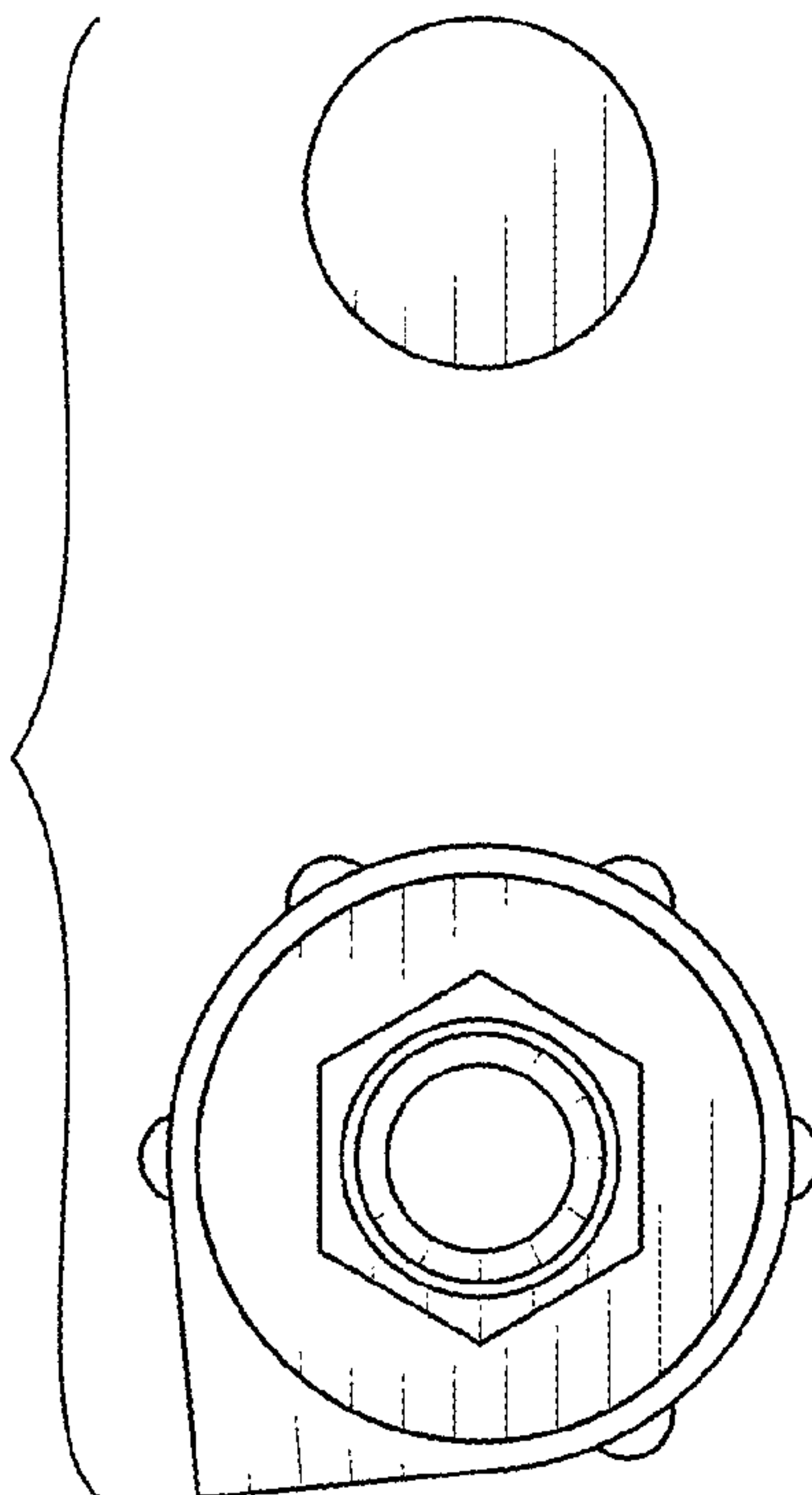

FIG. 4

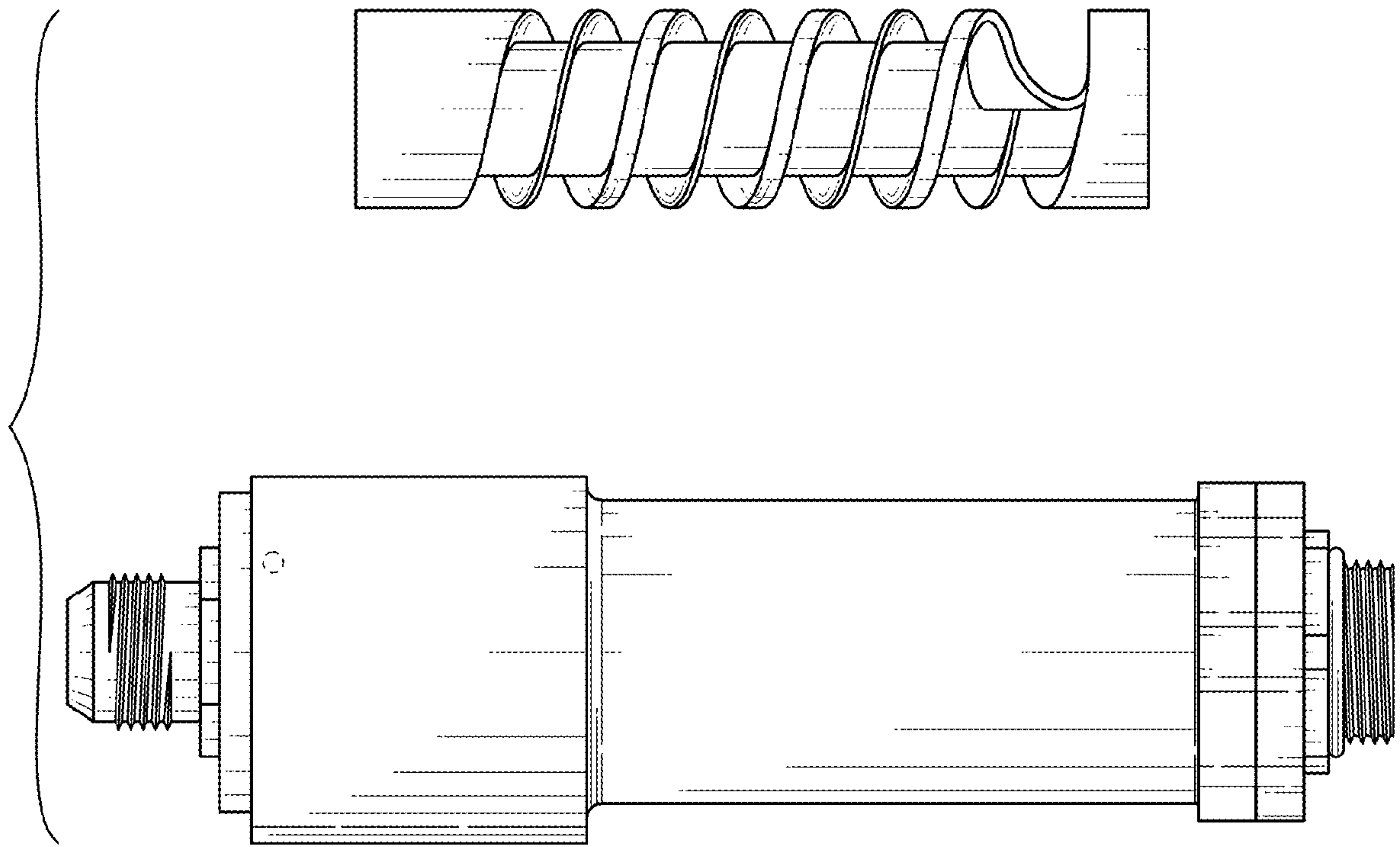

FIG. 5

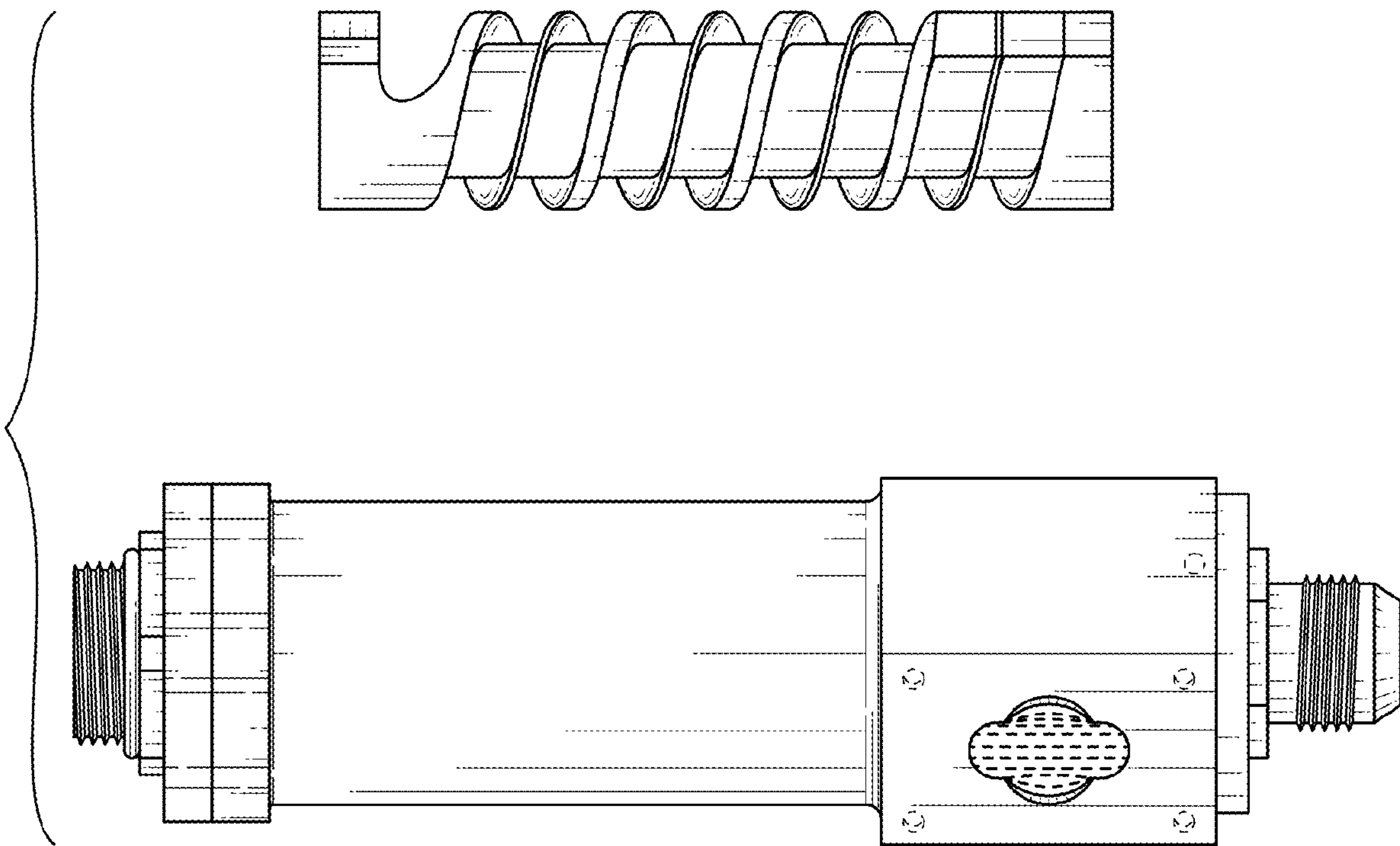

FIG. 6

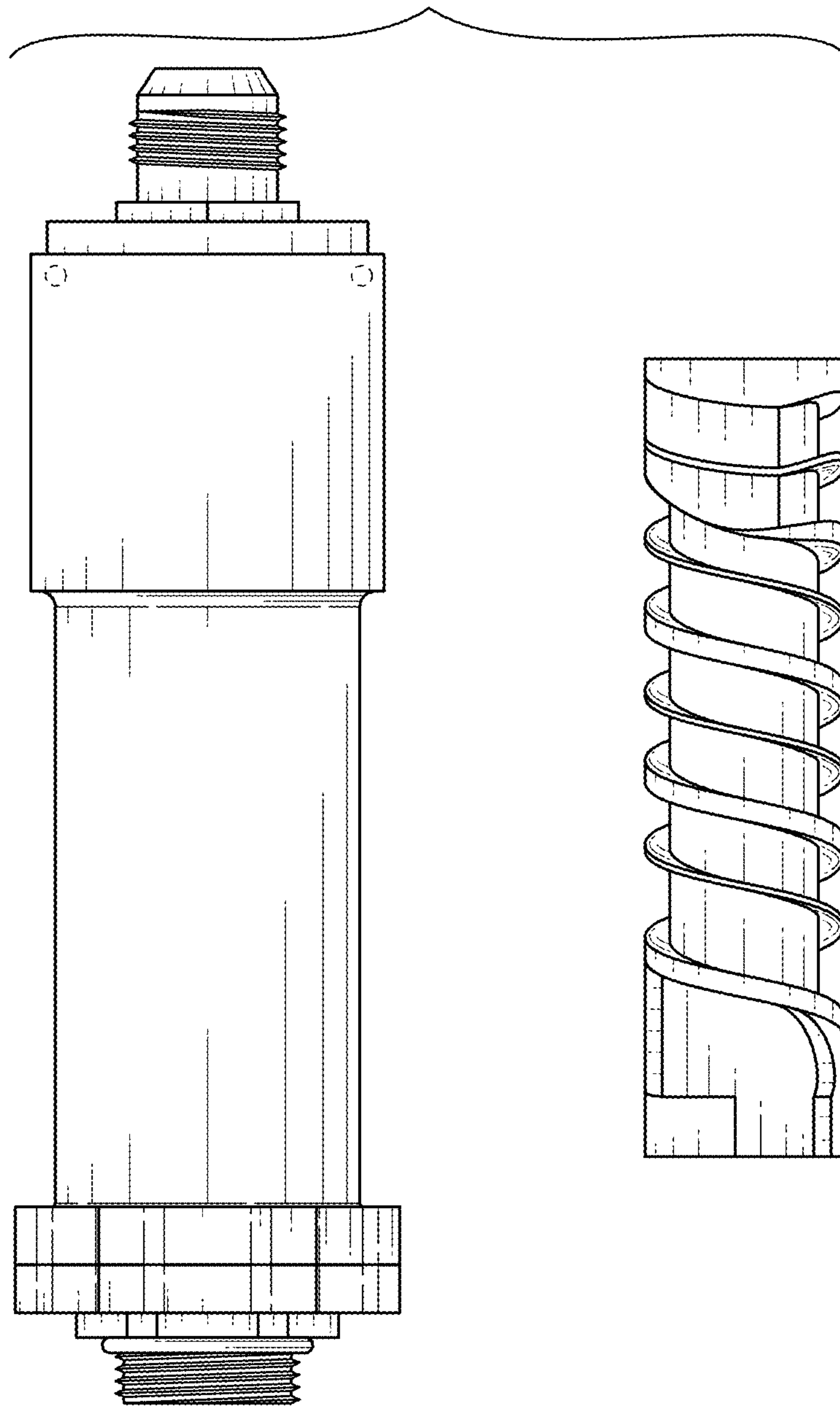

FIG. 7

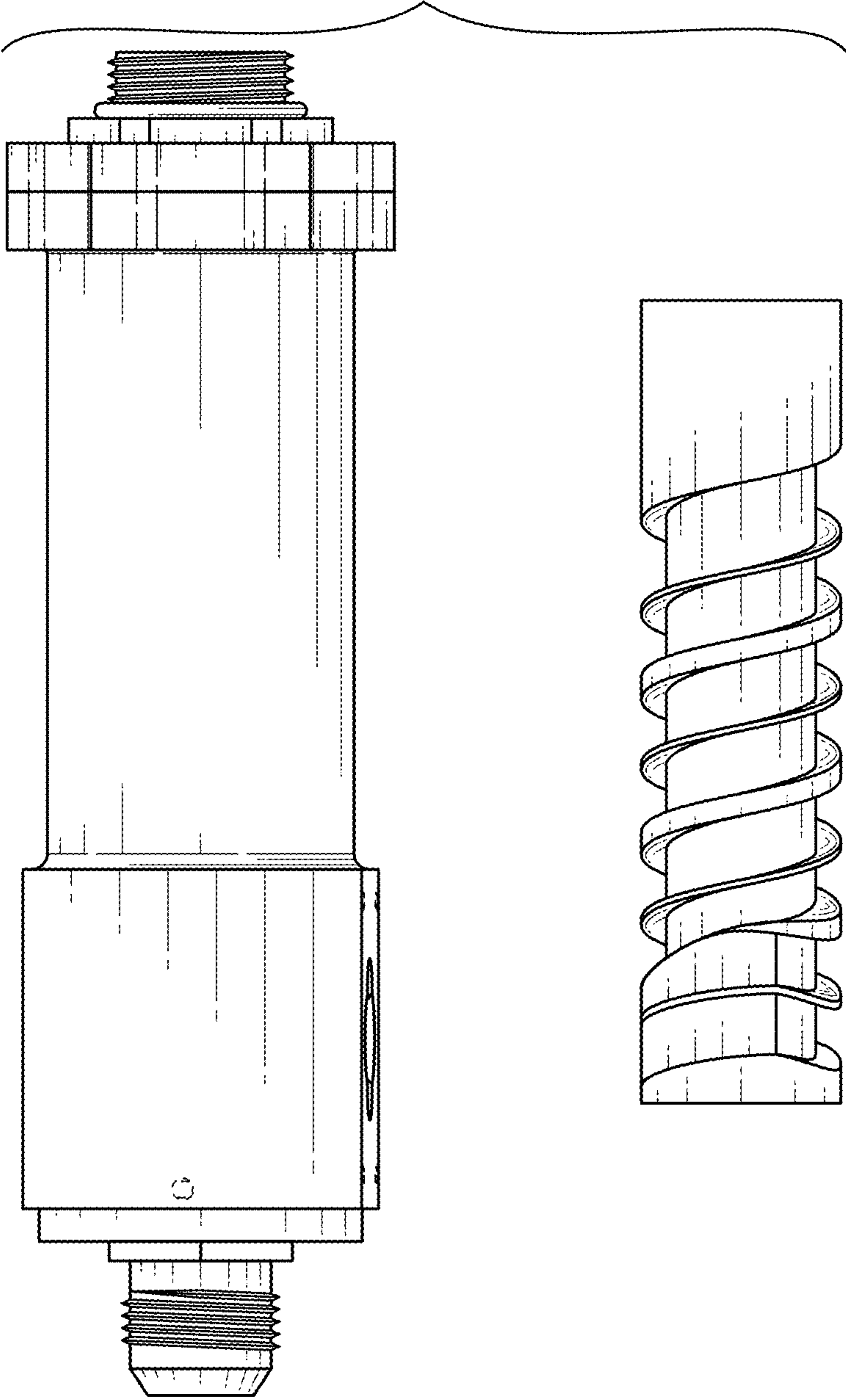

FIG. 8

UNITED STATES PATENT AND TRADEMARK OFFICE
CERTIFICATE OF CORRECTION

PATENT NO. : D950,607 S
APPLICATION NO. : 29/751239
DATED : May 3, 2022
INVENTOR(S) : Gary D. Armstrong

Page 1 of 1

It is certified that error appears in the above-identified patent and that said Letters Patent is hereby corrected as shown below:

On the Title Page

Column 2, item (57), under 'DESCRIPTION', Line 10, delete "FIG. 2; and," and insert -- FIG. 2:
and --, therefor.

Column 2, item (57), under 'DESCRIPTION', Line 13, delete "spearator" and insert -- separator --,
therefor.

Signed and Sealed this
Fourth Day of July, 2023

Katherine Kelly Vidal
Director of the United States Patent and Trademark Office