

US00D950465S

(12) **United States Design Patent** (10) **Patent No.:** **US D950,465 S**
Sturdza et al. (45) **Date of Patent:** **** May 3, 2022**

(54) **AIRPLANE**
(71) Applicant: **Aerion Intellectual Property Management Corporation**,
Wilmington, DE (US)
(72) Inventors: **Peter Sturdza**, Redwood City, CA
(US); **Spencer Fugal**, Reno, NV (US);
Alex Haas, Reno, NV (US)

D257,338 S * 10/1980 McComas D12/332
D269,176 S * 5/1983 Friebel D12/333
4,998,689 A * 3/1991 Woodcock B64C 3/40
244/46
D317,003 S * 5/1991 Tribe D12/16.1
5,062,595 A * 11/1991 Maxworthy B64C 23/06
244/214
D370,456 S * 6/1996 Buchsel D12/319
D477,561 S * 7/2003 Nelson D12/319

(Continued)

(**) Term: **15 Years**

OTHER PUBLICATIONS

(21) Appl. No.: **29/729,608**

Supersonic Flight, by Aviation International News on YouTube, dated Jun. 2, 2021. found online [Jun. 30, 2021] https://www.youtube.com/watch?v=X6NIGw_Cd-Q.*

(22) Filed: **Mar. 27, 2020**

(51) **LOC (13) Cl.** **12-07**

(52) **U.S. Cl.**
USPC **D12/319**

Primary Examiner — Marissa J Cash
(74) *Attorney, Agent, or Firm* — Brownstein Hyatt Farber Schreck, LLP

(58) **Field of Classification Search**
USPC D12/1, 2, 3, 4, 16.1, 319, 321, 322, 323,
D12/324, 326, 327-344, 345; D21/436,
D21/439, 440, 441, 442, 444, 446, 447,
D21/448, 449, 450, 451, 452, 453
CPC B64C 2201/022; B64C 27/00; B64C
2201/14; B64C 19/00; B64D 27/26;
B64B 1/22

(57) **CLAIM**
The ornamental design for an airplane, as shown.

See application file for complete search history.

DESCRIPTION

(56) **References Cited**

U.S. PATENT DOCUMENTS

D172,588 S * 7/1954 Fleming et al. D12/342
D179,348 S * 12/1956 Johnson D12/337
D199,509 S * 11/1964 Wadington D12/16.1
D202,311 S * 9/1965 Rellis D12/337
D202,749 S * 11/1965 Holtby D12/343
D206,298 S * 11/1966 Rellis D12/337
D208,338 S * 8/1967 Tecton D12/333
D213,528 S * 3/1969 Rellis D12/332
D216,921 S * 3/1970 Friebel D12/341
D230,474 S * 2/1974 Rellis D12/340
D231,094 S * 4/1974 Schmidt D12/332
D251,721 S * 5/1979 Stewart D12/333

FIG. 1 is a perspective view of an airplane showing the new design;
FIG. 2 is a front view thereof;
FIG. 3 is a rear view thereof;
FIG. 4 is a left side view thereof;
FIG. 5 is a right side view thereof;
FIG. 6 is a bottom view thereof;
FIG. 7 is a top view thereof;
FIG. 8 is another perspective view thereof; and,
FIG. 9 is yet another perspective view thereof.
The broken lines immediately adjacent the shaded areas represent the bounds of the claimed design while all other broken lines are directed to portions of the airplane and are for illustrative purposes only; the broken lines form no part of the claimed design.

1 Claim, 9 Drawing Sheets

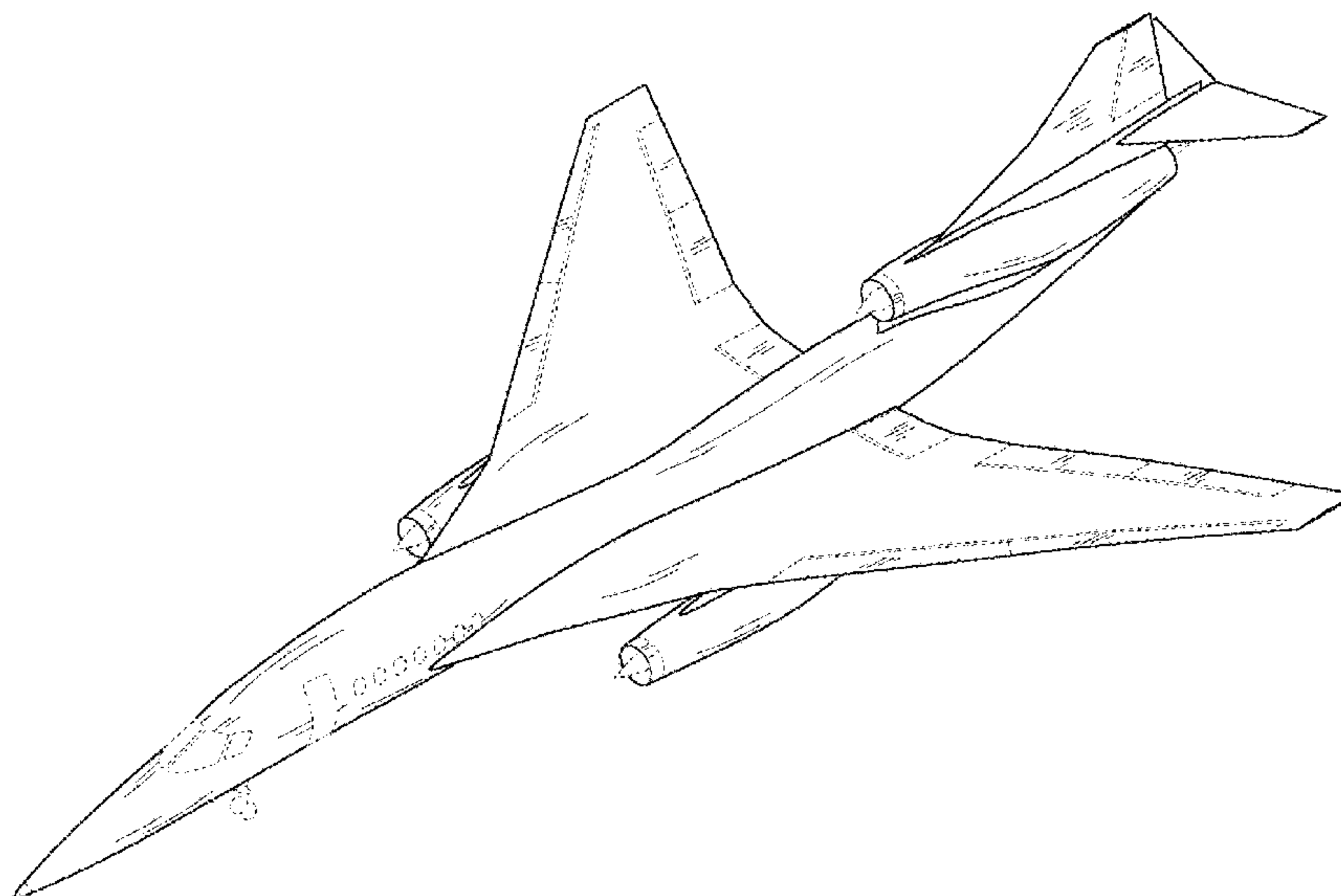

(56)

References Cited

U.S. PATENT DOCUMENTS

6,698,684 B1 * 3/2004 Henne B64C 23/04
181/211
D504,654 S * 5/2005 Graham D12/319
7,624,942 B2 * 12/2009 Roberge B64C 27/24
244/62
8,083,171 B2 * 12/2011 Henne B64C 30/00
244/1 N
8,453,961 B2 * 6/2013 Lugg B64C 30/00
244/13
10,791,657 B1 * 9/2020 Barnes H02G 3/0406
2009/0206206 A1 * 8/2009 Chase B64C 30/00
244/199.4
2011/0095137 A1 * 4/2011 Tracy B64C 3/10
244/35 R

* cited by examiner

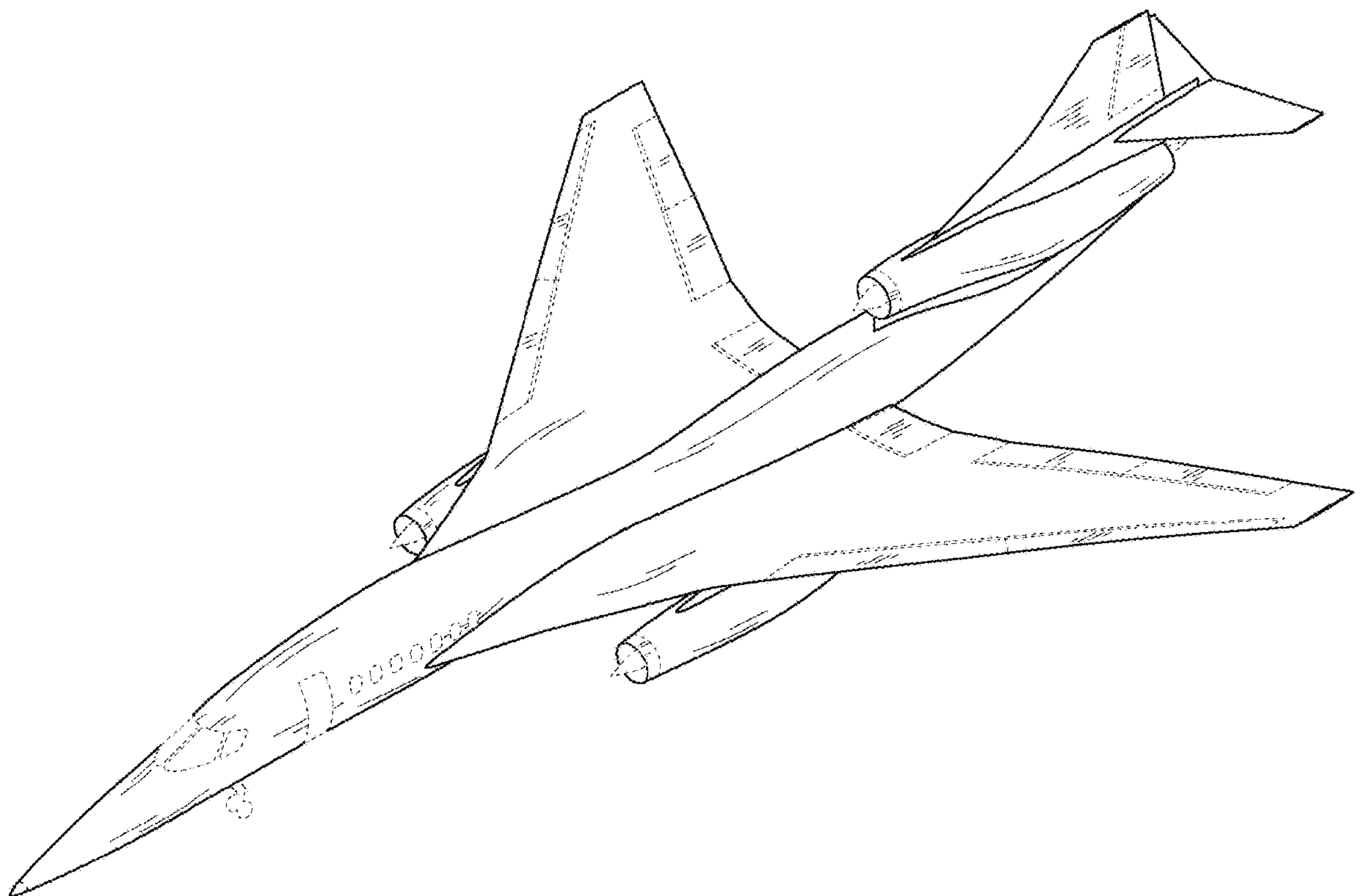

FIG. 1

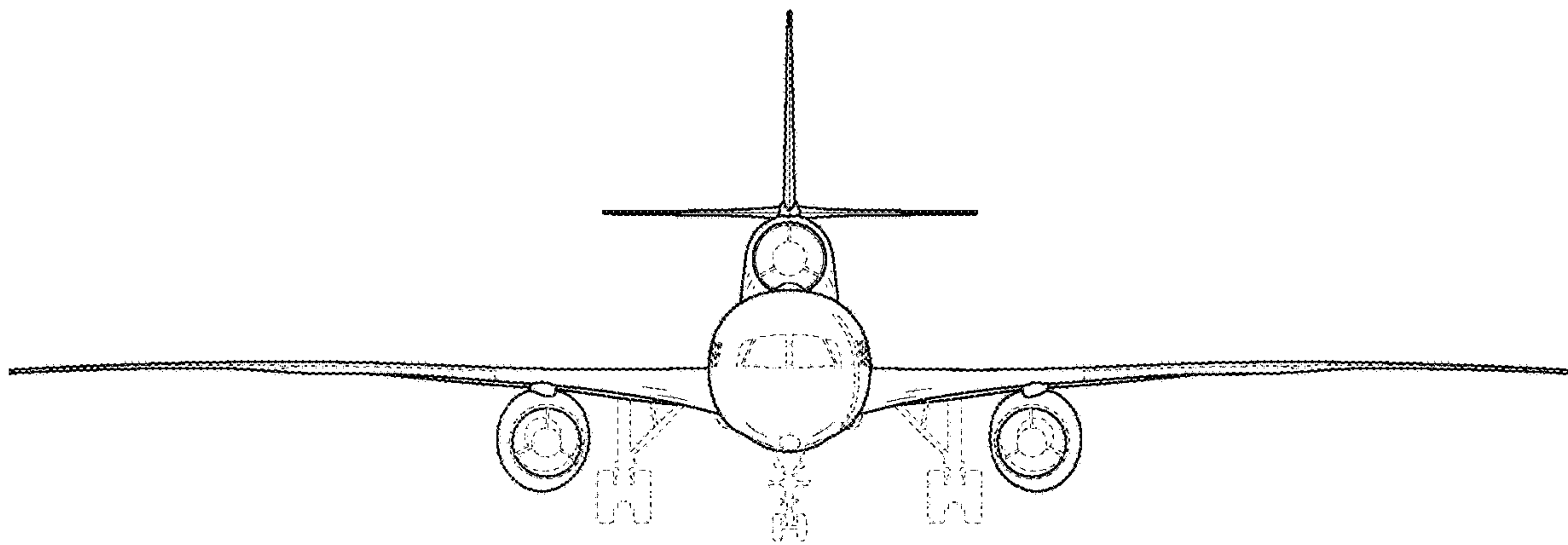

FIG. 2

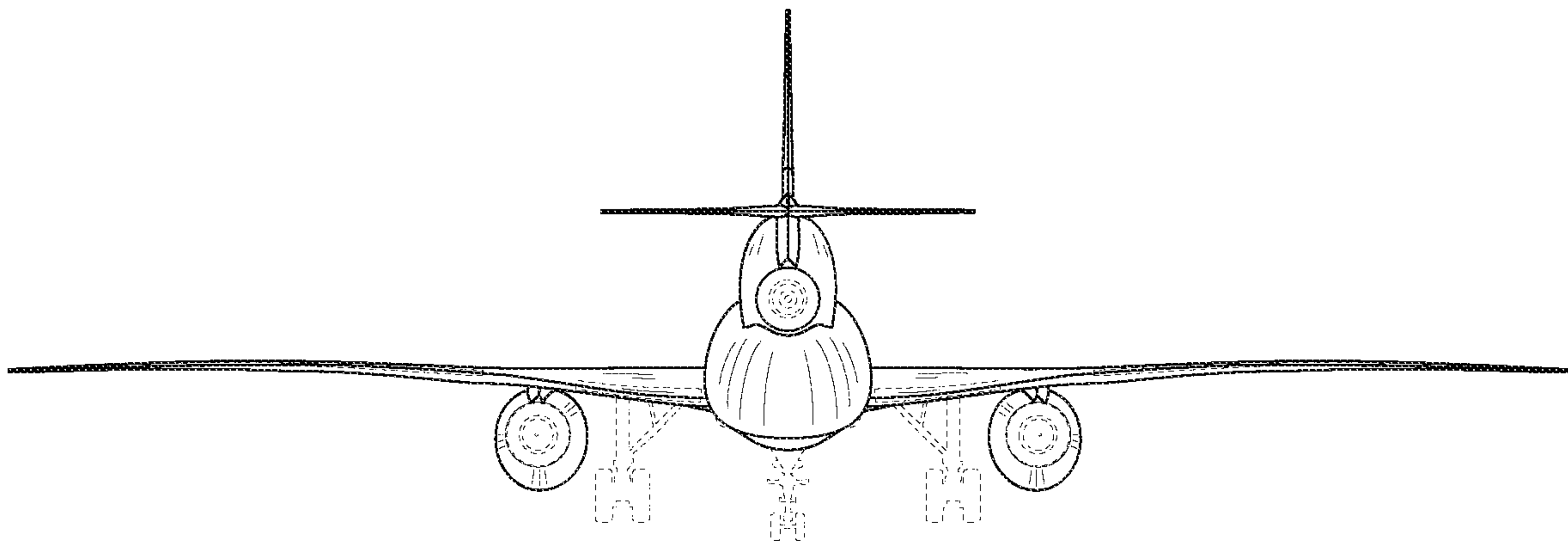

FIG. 3

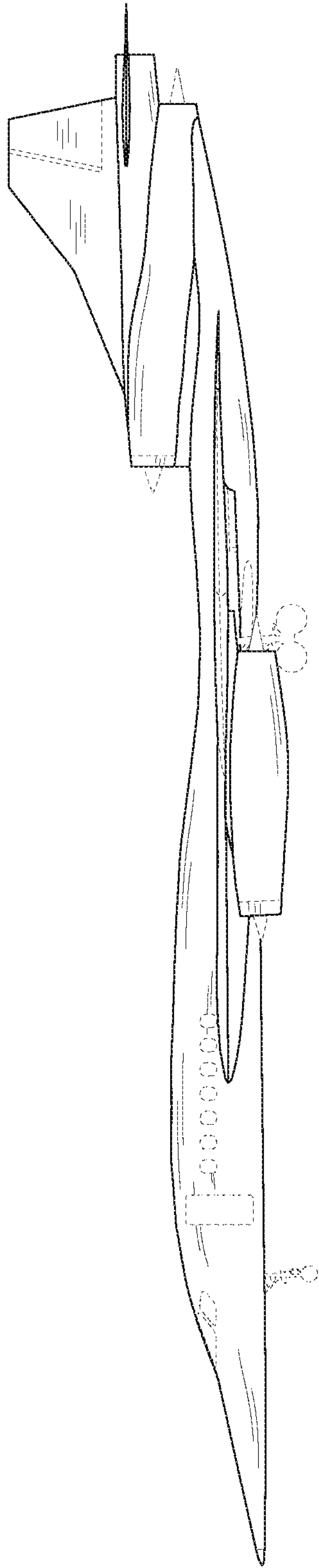

FIG. 4

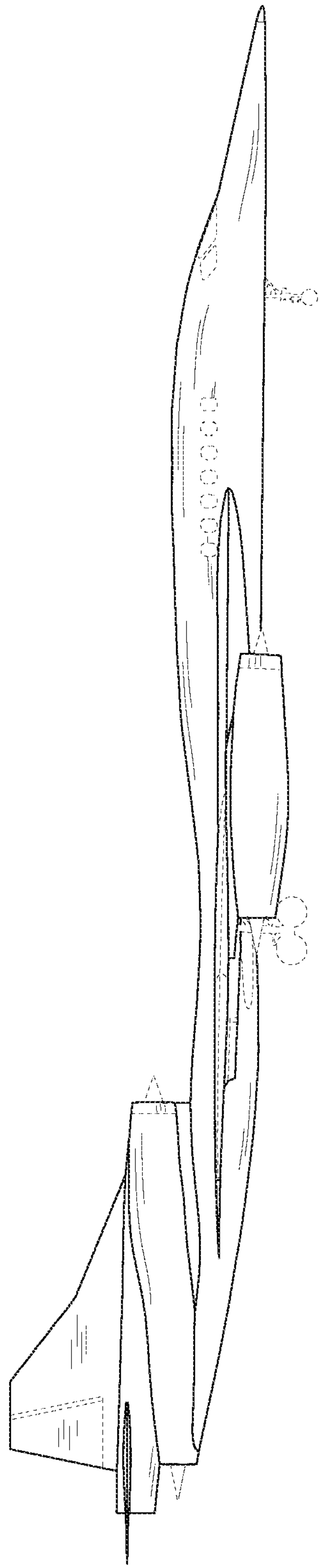

FIG. 5

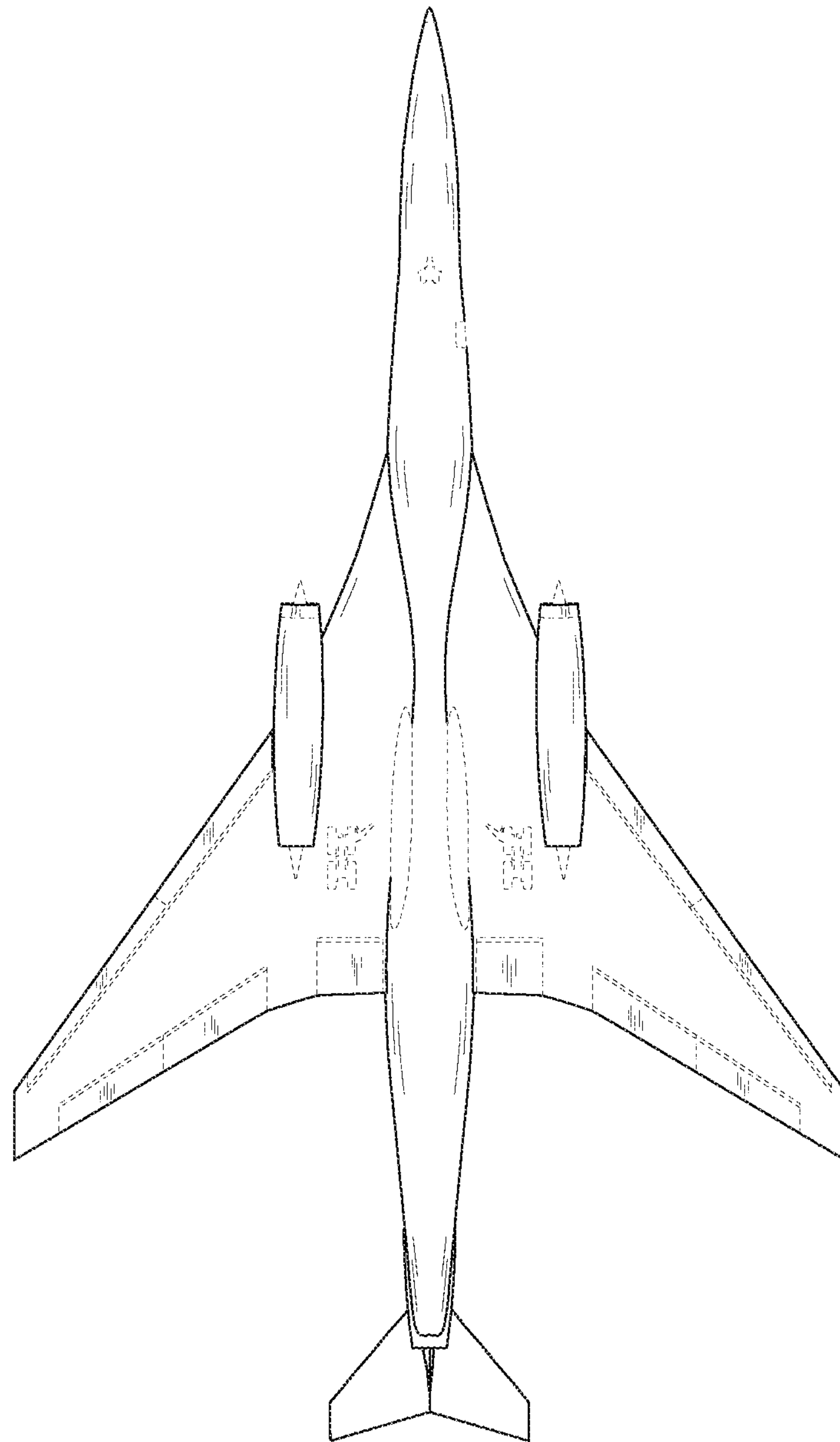

FIG. 6

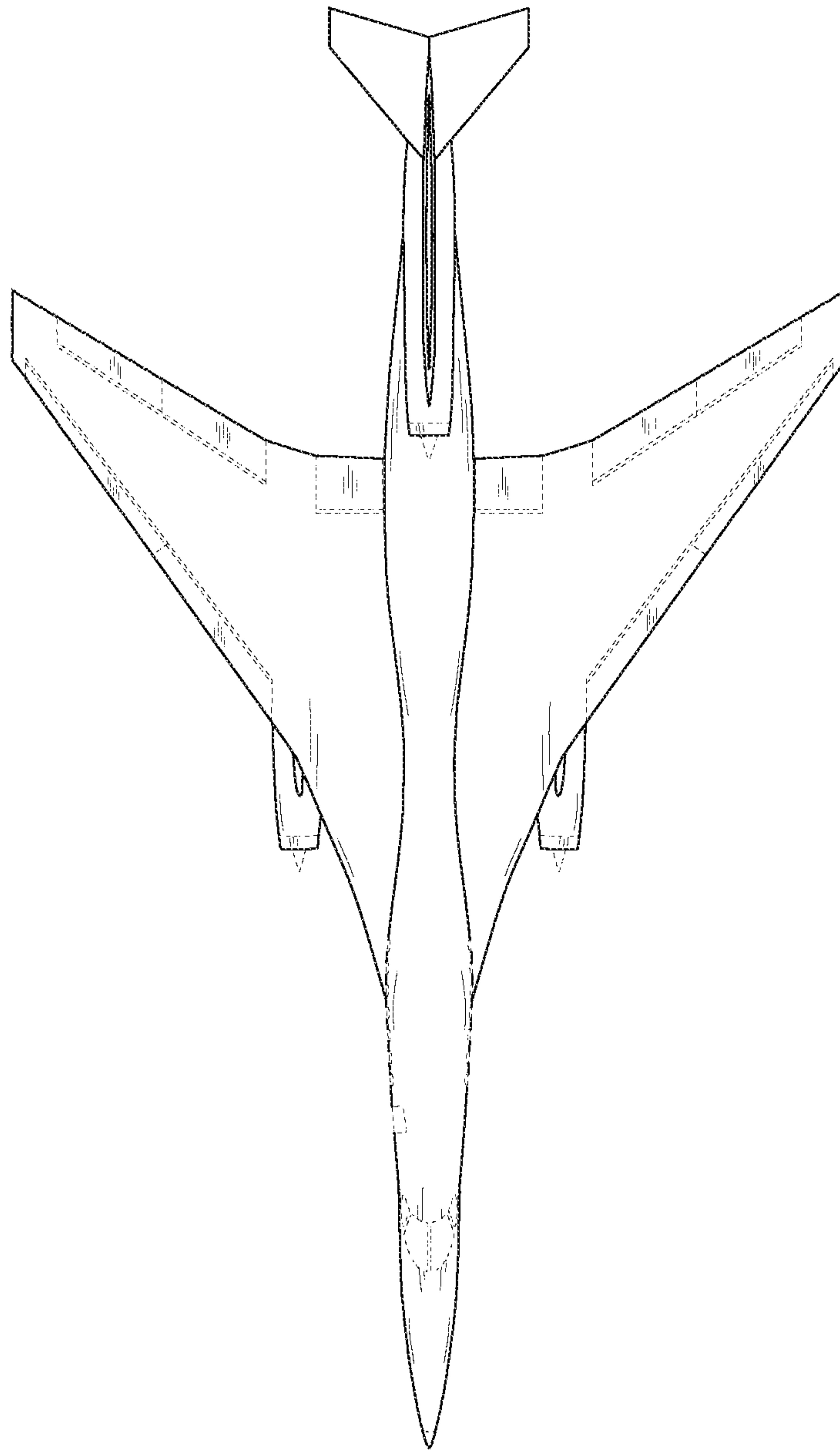

FIG. 7

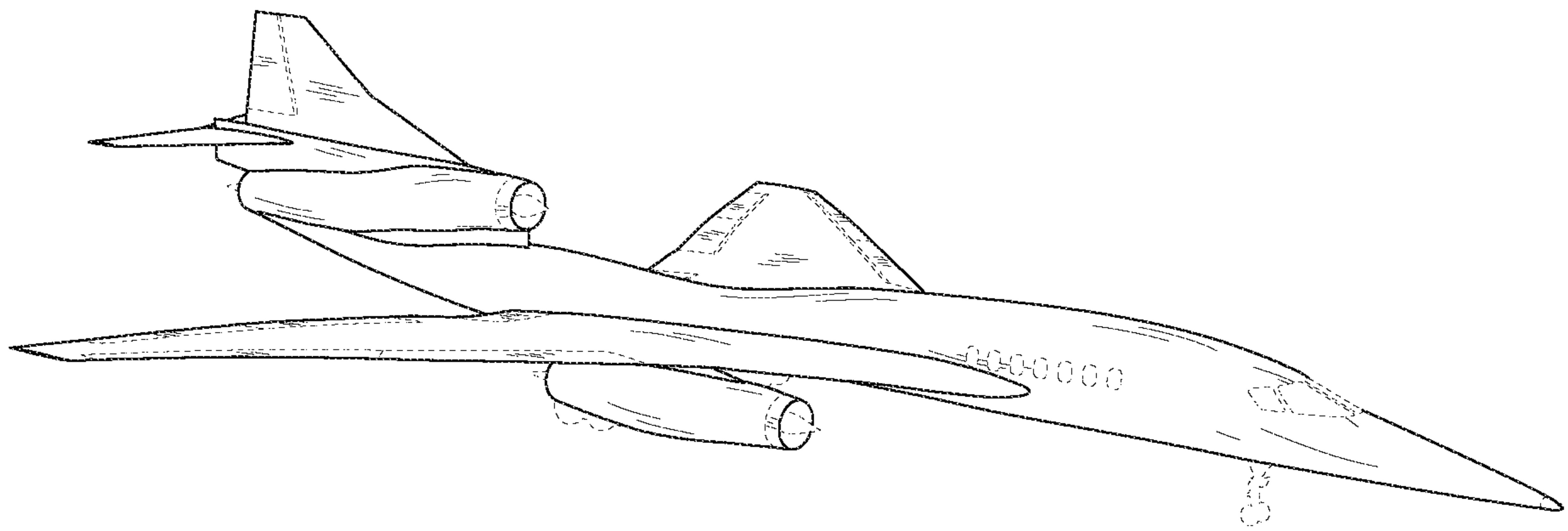

FIG. 8

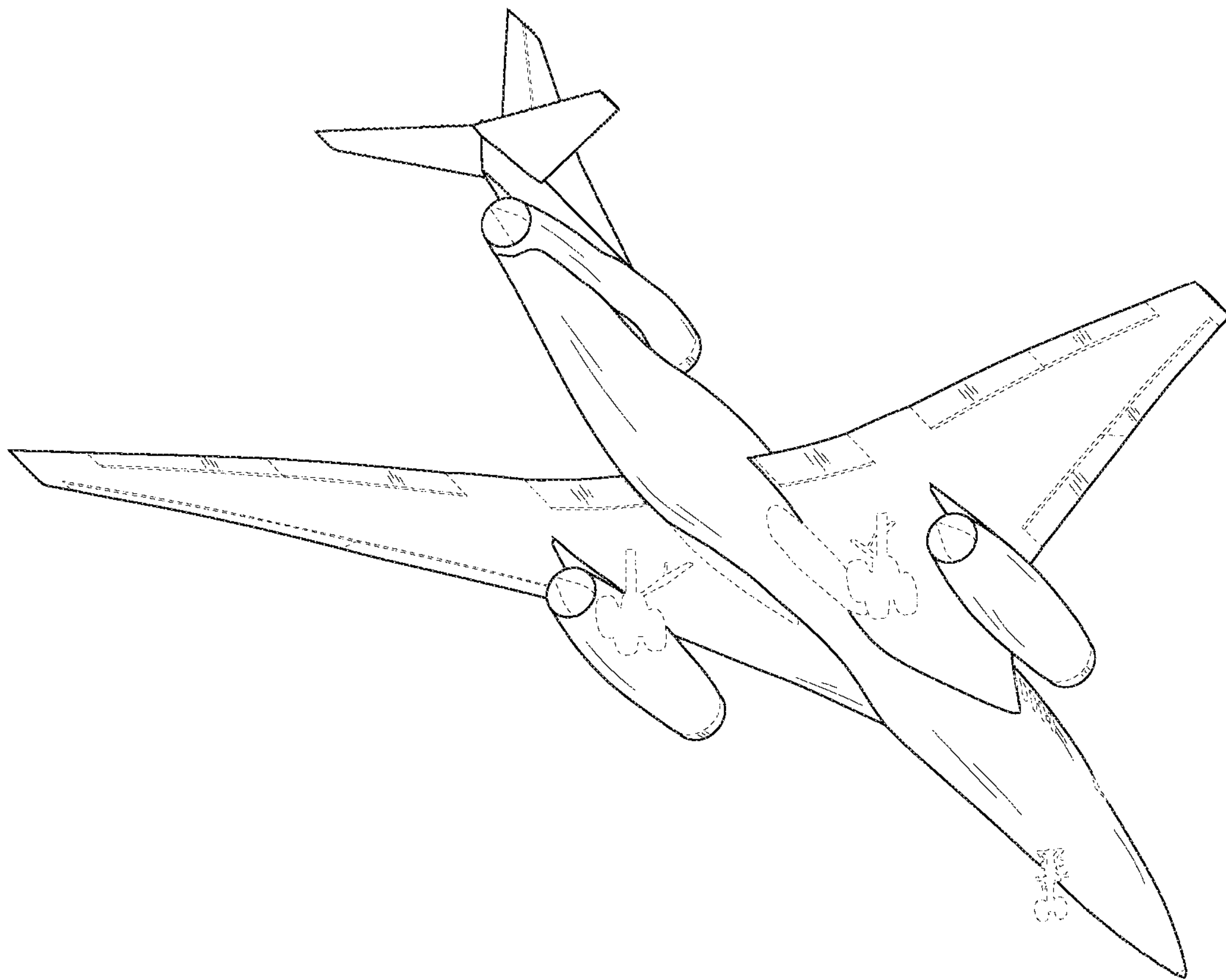

FIG. 9