

US00D949757S

(12) **United States Design Patent**
Conroy et al.

(10) **Patent No.:** **US D949,757 S**

(45) **Date of Patent:** **** Apr. 26, 2022**

(54) **FLOATING MOORING FENDER**

(71) Applicants: **Austin Conroy**, Nantucket, MA (US);
Bruce Weddendorf, Huntsville, AL
(US)

(72) Inventors: **Austin Conroy**, Nantucket, MA (US);
Bruce Weddendorf, Huntsville, AL
(US)

(**) **Term:** **15 Years**

(21) **Appl. No.:** **29/736,753**

(22) **Filed:** **Jun. 2, 2020**

(51) **LOC (13) Cl.** **12-16**

(52) **U.S. Cl.**
USPC **D12/168**

(58) **Field of Classification Search**
USPC D12/168, 167, 300, 316, 317; D10/107;
D21/803; D3/300, 267, 254; D6/601;
D16/243; D30/160
CPC ... B63B 59/02; B63B 2059/025; B63B 22/00;
E02B 3/26
See application file for complete search history.

(56) **References Cited**

U.S. PATENT DOCUMENTS

D308,192 S *	5/1990	Ellison	D12/168
D364,595 S *	11/1995	Doyle	D12/168
D366,005 S *	1/1996	Beyer-Olsen	441/6
D389,642 S *	1/1998	Nadel	D3/254
D430,083 S *	8/2000	Spearin	D12/168
D452,466 S *	12/2001	Skulnick	D12/168
D453,876 S *	2/2002	Moor	D3/300
6,435,122 B1 *	8/2002	Skulnick	B63B 59/02 114/219
D487,238 S *	3/2004	Beyer-Olsen	D12/168
D510,895 S *	10/2005	Nelson	D12/168
D544,155 S *	6/2007	Lamstein	D30/158

D547,650 S *	7/2007	Limber	D9/419
D617,694 S *	6/2010	Kunkemoeller	D12/168
D689,654 S *	9/2013	Oblack	D30/160
D730,429 S *	5/2015	Anari	D16/243
D737,052 S *	8/2015	James	D3/300
D759,553 S *	6/2016	Karpinski	D12/168
D759,554 S *	6/2016	Karpinski	D12/168
D760,627 S *	7/2016	Karpinski	D12/168
D762,530 S *	8/2016	Karpinski	D12/168
D763,573 S *	8/2016	Klein	D3/254
D777,616 S *	1/2017	Karpinski	D12/168
D783,471 S *	4/2017	Kalkstein	D12/168
D806,440 S *	1/2018	Pulver	D6/601
D852,492 S *	7/2019	Anderson	D3/217
D860,635 S *	9/2019	Connelly	D3/201

* cited by examiner

Primary Examiner — Michelle E. Wilson

Assistant Examiner — Clese Moore, Jr.

(74) *Attorney, Agent, or Firm* — Angela Holt; Bradley Arant Boult Cummings LLP

(57) **CLAIM**

The ornamental design for a floating mooring fender, as shown and described.

DESCRIPTION

FIG. 1 is a top perspective view of a floating mooring fender, showing our new design;

FIG. 2 is a front-end view thereof, with the rear end view being identical to the front-end view;

FIG. 3 is a top plan view thereof, with the bottom plan view being identical to the top plan view; and,

FIG. 4 is a right-side elevational view thereof, with the left side elevational view being identical to the right-side elevational view.

The broken lines shown illustrate portions of the floating mooring fender that form no part of the claimed design.

1 Claim, 2 Drawing Sheets

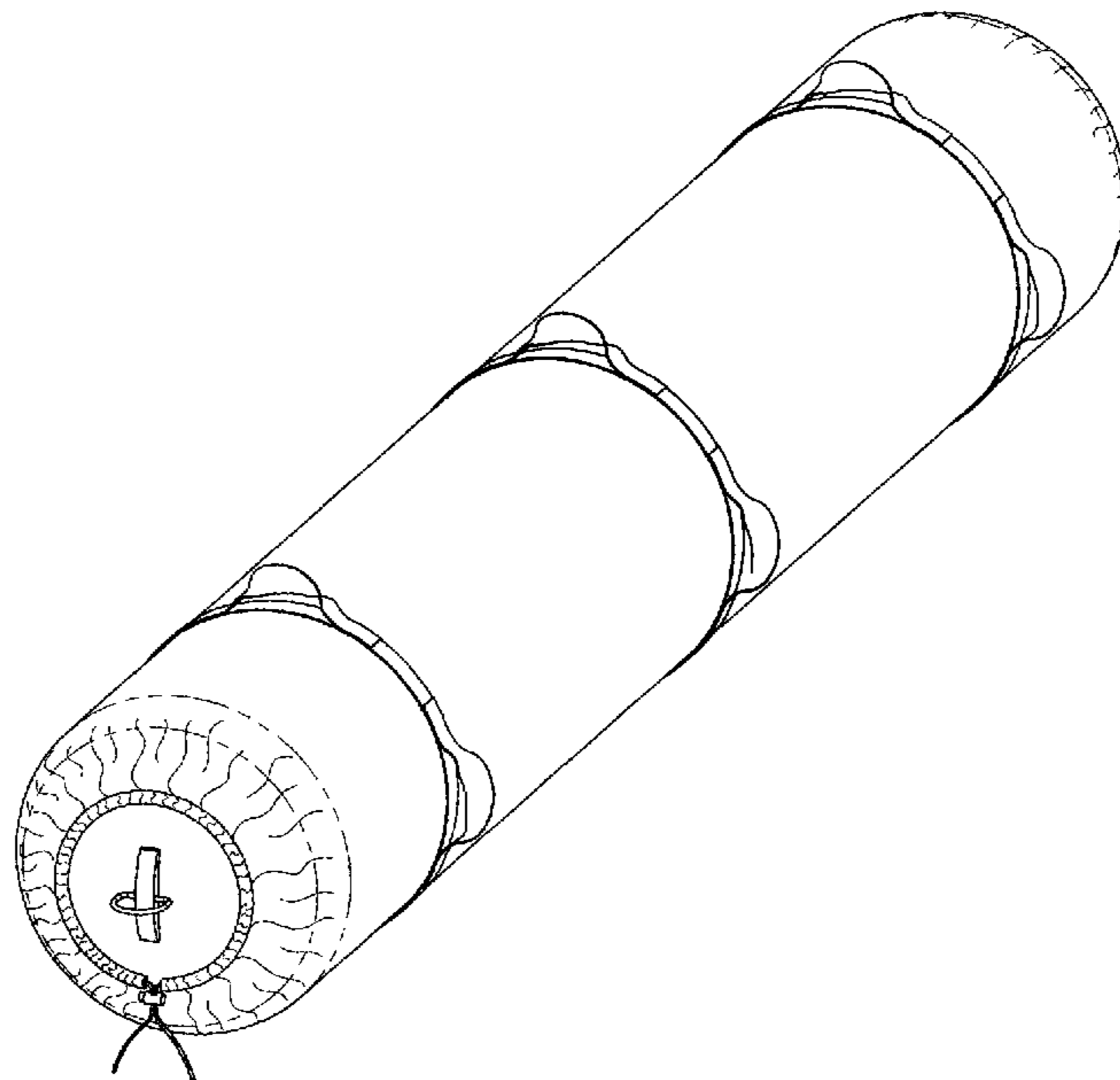

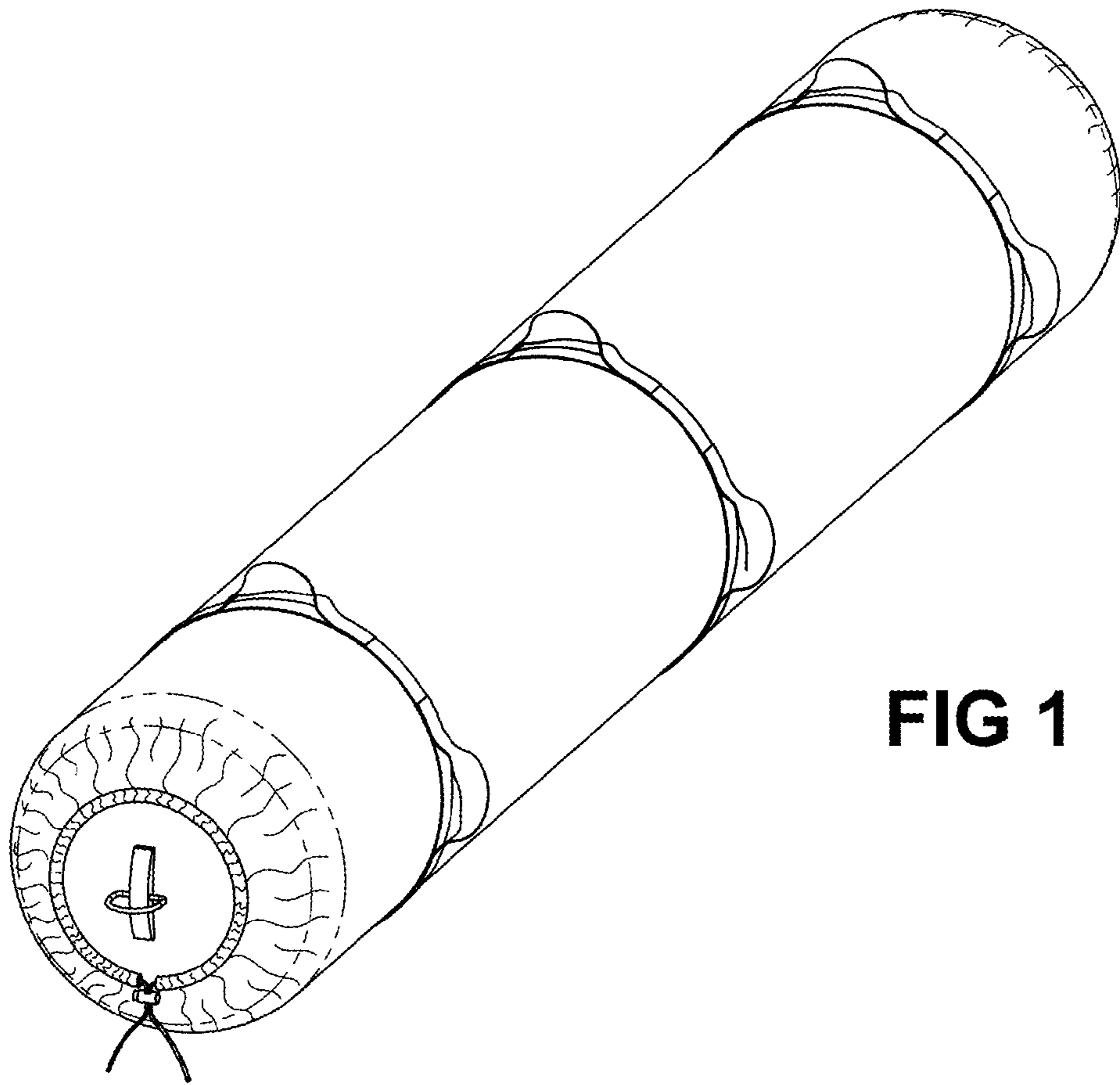

FIG 1

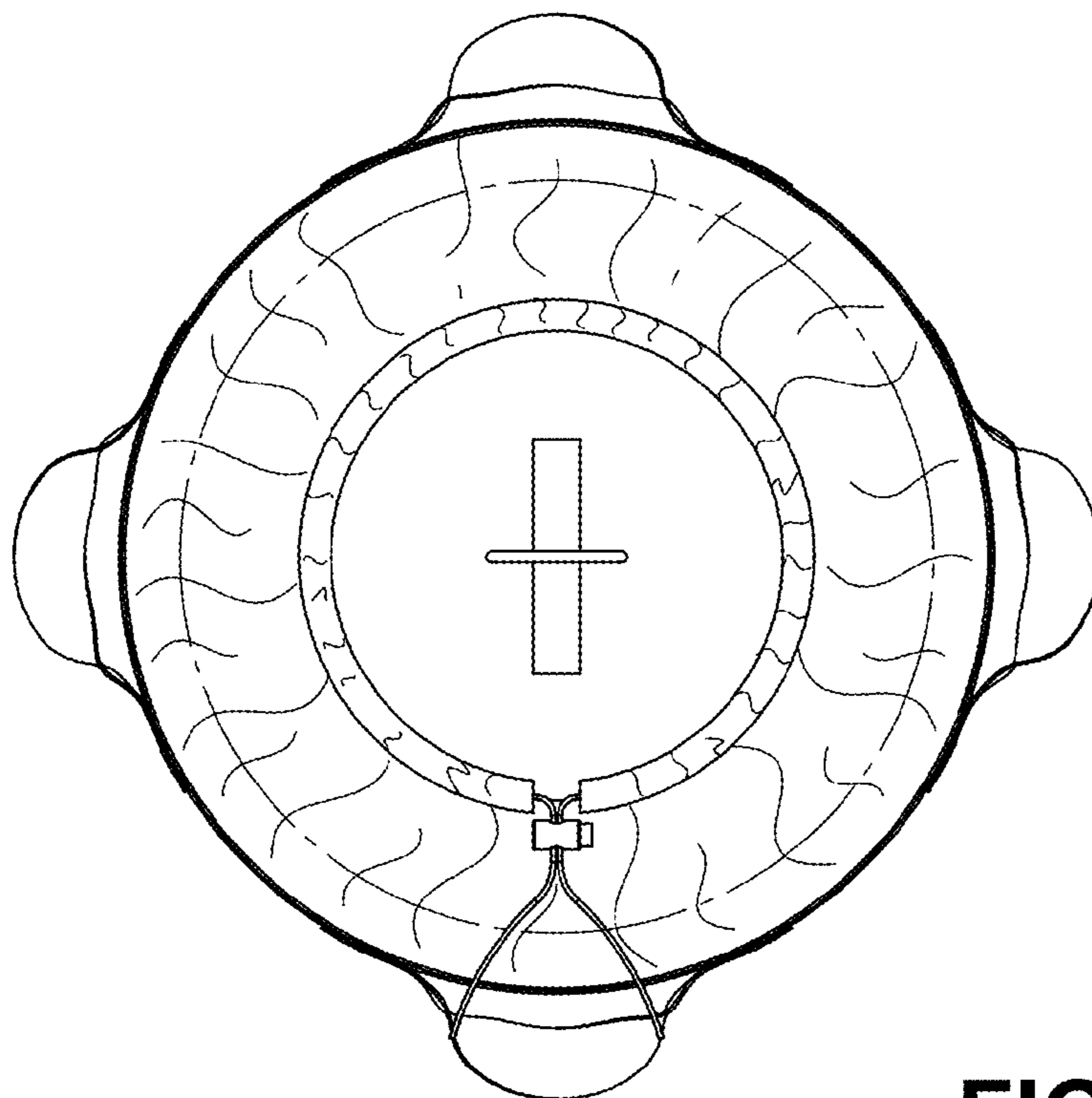

FIG 2

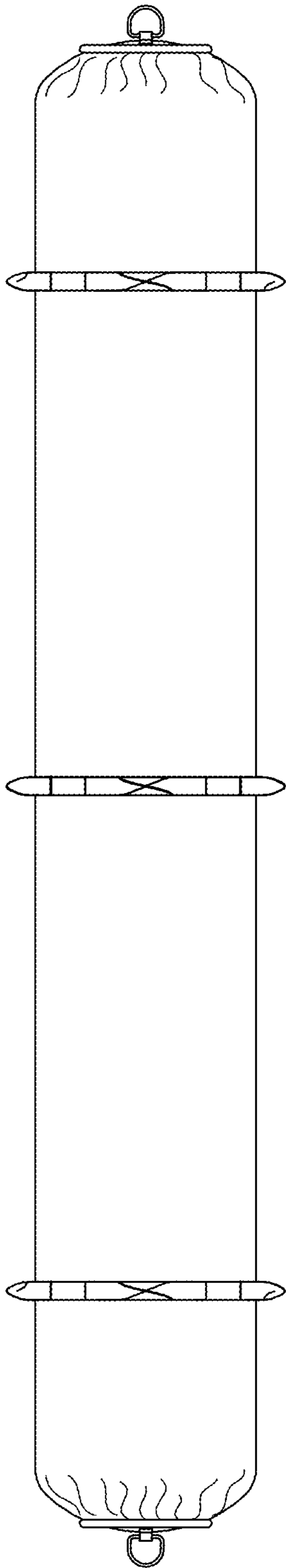

FIG 3

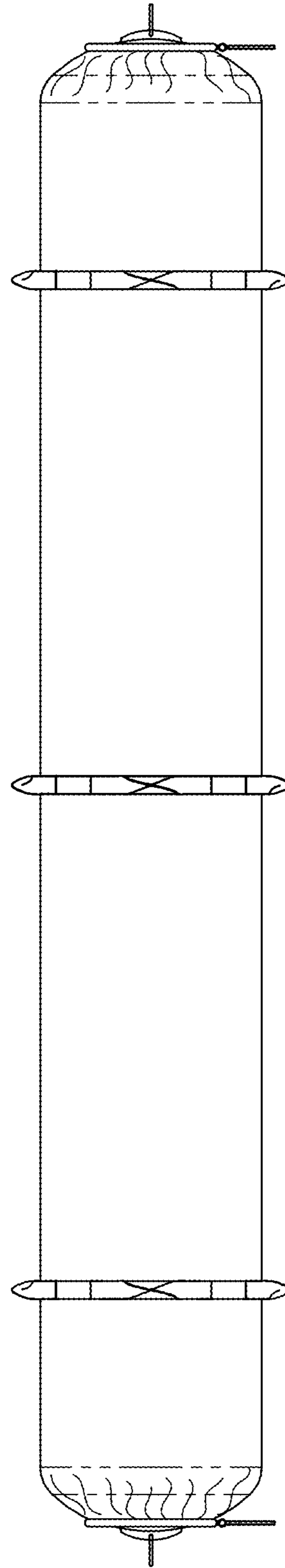

FIG 4