



US00D949752S

(12) **United States Design Patent**
McGaughy

(10) **Patent No.:** **US D949,752 S**
(45) **Date of Patent:** **** Apr. 26, 2022**

(54) **CROSSMEMBER FOR VEHICLE**

(71) Applicant: **Steve McGaughy**, Fresno, CA (US)
(72) Inventor: **Steve McGaughy**, Fresno, CA (US)
(**) Term: **15 Years**
(21) Appl. No.: **29/758,448**

(22) Filed: **Nov. 16, 2020**
(51) **LOC (13) Cl.** **12-16**
(52) **U.S. Cl.**
USPC **D12/159**
(58) **Field of Classification Search**
USPC D12/159, 160, 161, 400; D8/349, 354
CPC B62D 21/02; B62D 21/03; B62D 21/09;
B62D 21/11; B62D 25/08; B21D 51/04;
B21D 47/01; B21D 22/02; B21D 53/88;
B60B 35/04
See application file for complete search history.

FOREIGN PATENT DOCUMENTS

KR 20160134893 A * 11/2016 B62D 21/03

OTHER PUBLICATIONS

McGaughys Lift Kit, Published date unavailable [online], [retrieved on Feb. 4, 2022]. Retrieved from the Internet: <http://mcgaughys.com/products/7-premium-lift-kit-silver-powder-coat-52003> (Year: 2022).*

* cited by examiner

Primary Examiner — Cary M Robinson

Assistant Examiner — Adam C Mager

(74) *Attorney, Agent, or Firm* — Acuity IP, LLC; Nathan S. Cassell

(57) **CLAIM**

The ornamental design for a crossmember for vehicle, as shown.

DESCRIPTION

(56) **References Cited**

U.S. PATENT DOCUMENTS

1,908,638	A *	5/1933	Maddock	B62D 21/02 280/800
D436,558	S *	1/2001	Fischer	D12/93
D749,466	S *	2/2016	Nosworthy	D12/159
11,084,531	B2 *	8/2021	Asai	B62D 21/02
2012/0285764	A1 *	11/2012	Compton	B62D 21/02 180/312
2013/0147236	A1 *	6/2013	Lee	B62D 21/11 296/203.02
2014/0145472	A1 *	5/2014	Tsuchiya	B62D 21/11 296/204
2019/0111748	A1 *	4/2019	Borde	B60G 9/003
2019/0193792	A1 *	6/2019	Saeki	B62D 25/08
2020/0079429	A1 *	3/2020	Asai	B62D 21/02

FIG. 1 is a top front perspective view of a crossmember for vehicle showing my new design;
FIG. 2 is a bottom front perspective view thereof;
FIG. 3 is a top rear perspective view thereof;
FIG. 4 is a bottom rear perspective view thereof;
FIG. 5 is a front elevational view thereof;
FIG. 6 is a rear elevational view thereof;
FIG. 7 is a right side elevational view thereof;
FIG. 8 is a left side elevational view thereof;
FIG. 9 is a top plan view thereof; and,
FIG. 10 is a bottom plan view thereof.
The broken lines showing portions of the crossmember for vehicle form no part of the claimed design.

1 Claim, 10 Drawing Sheets

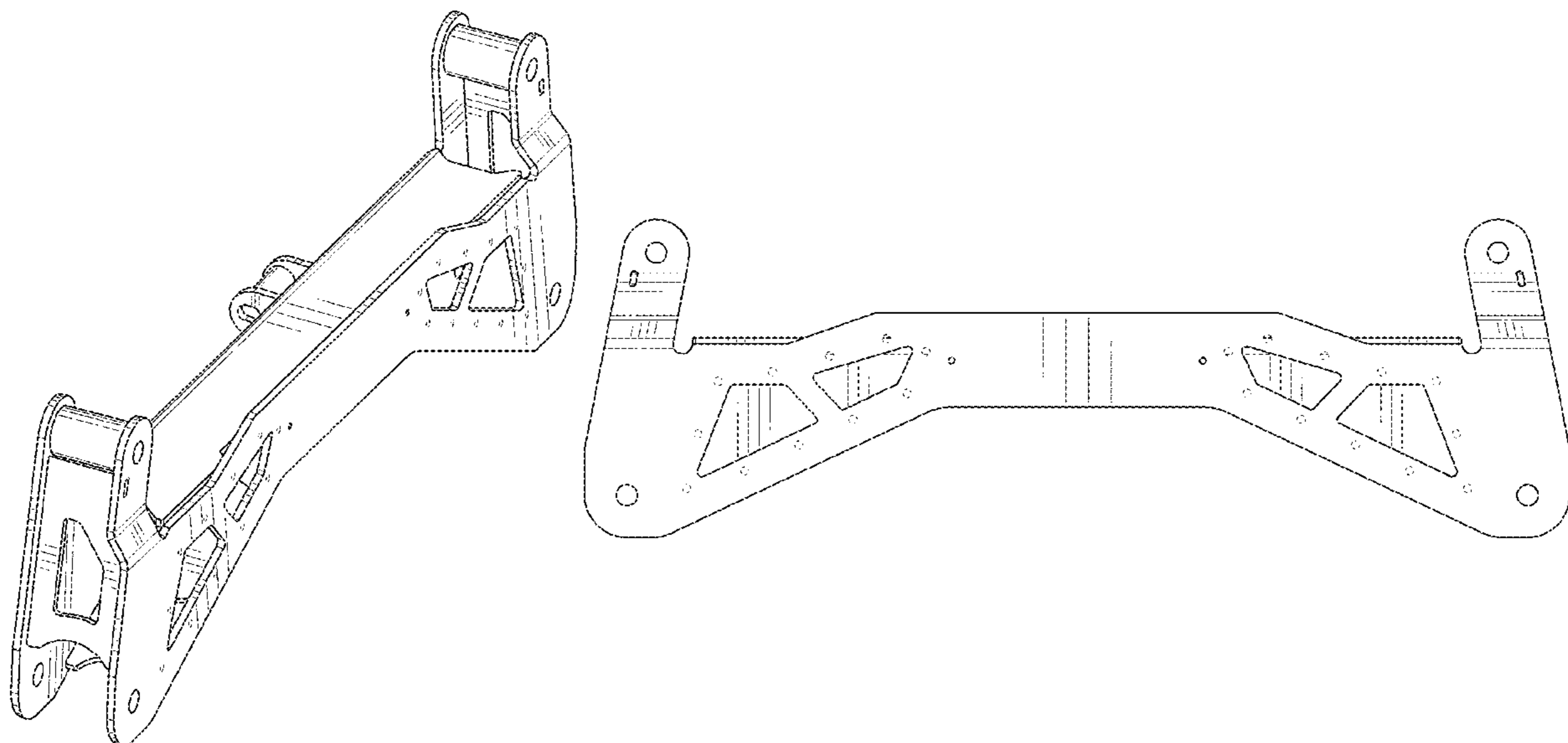

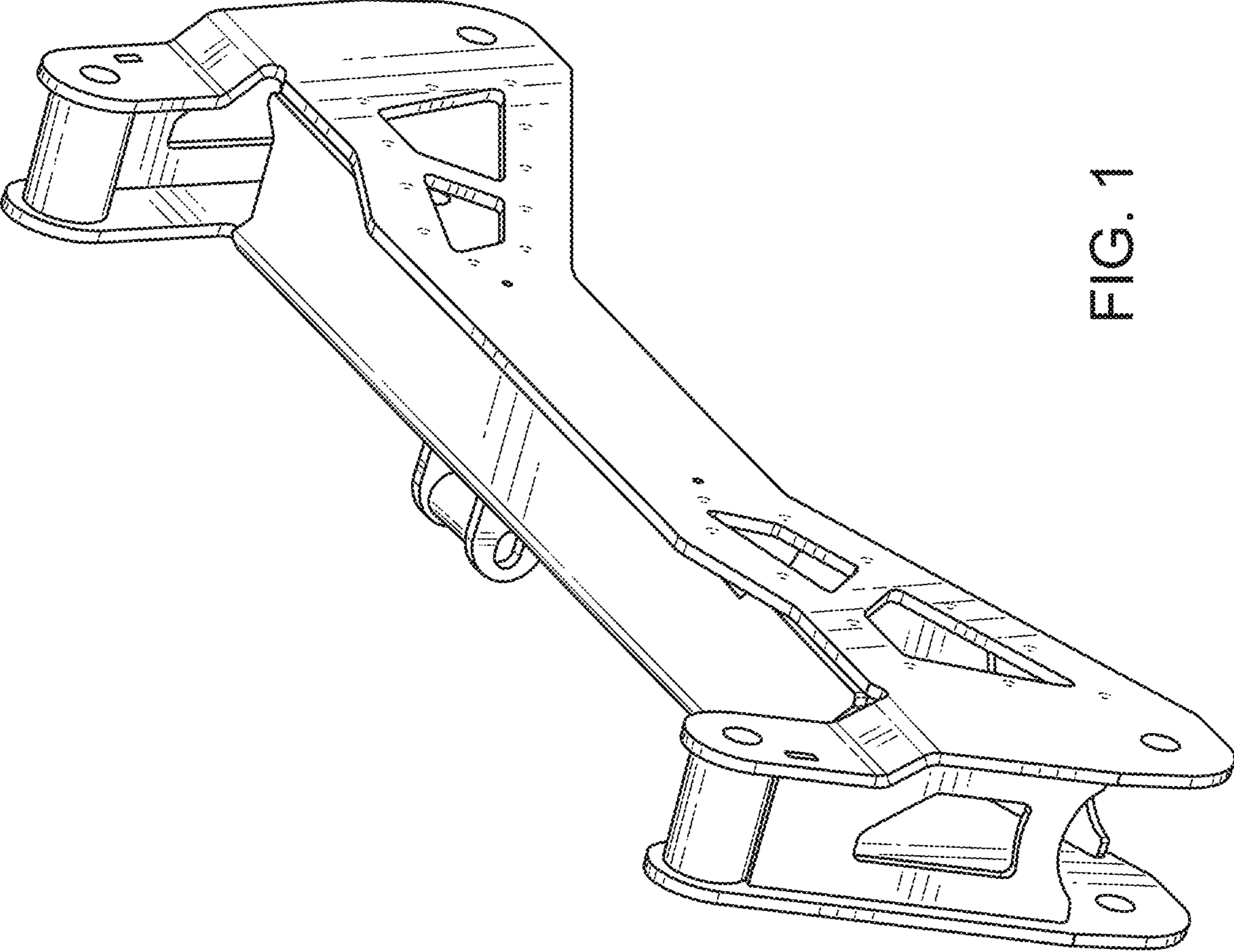

FIG. 1

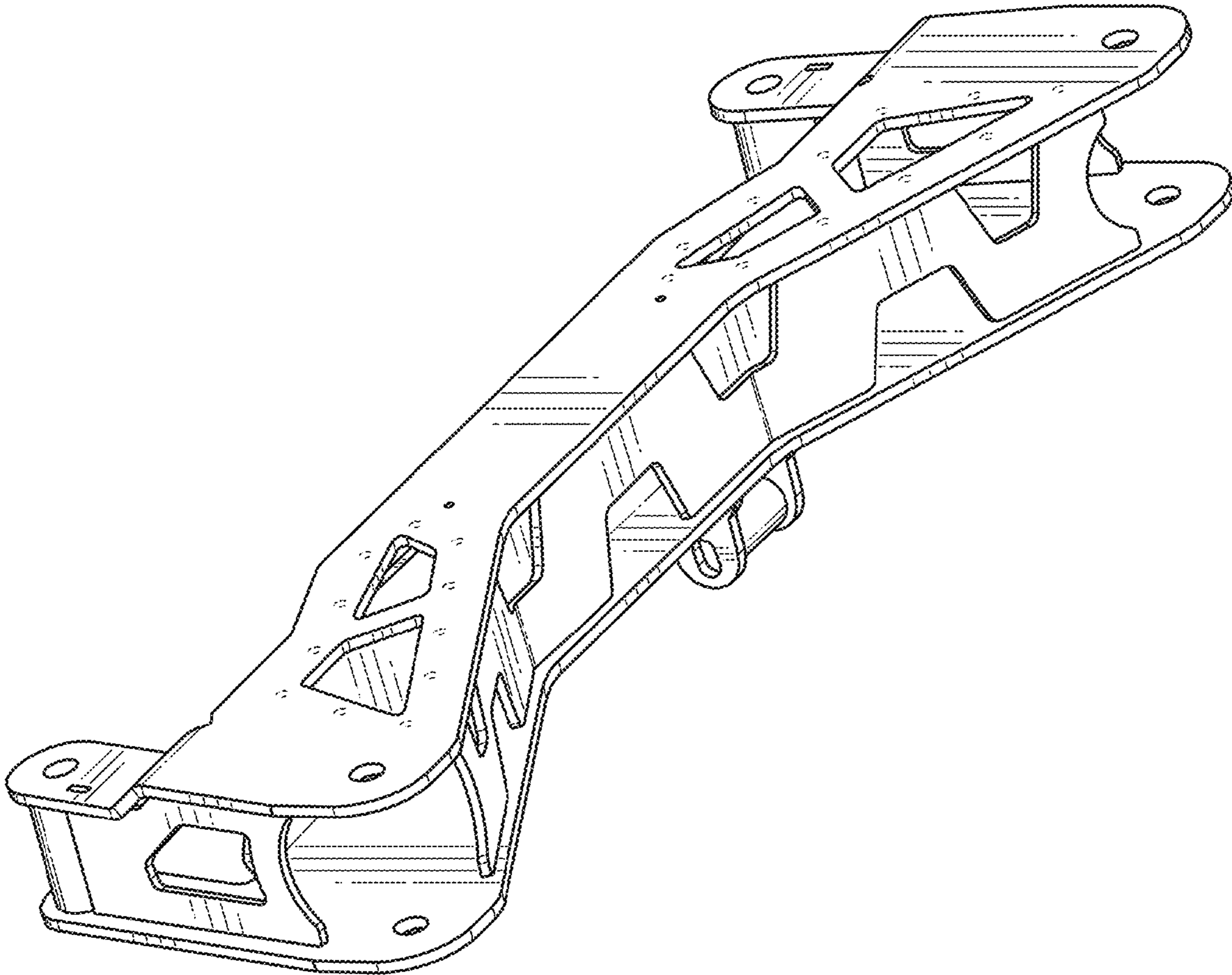

FIG. 2

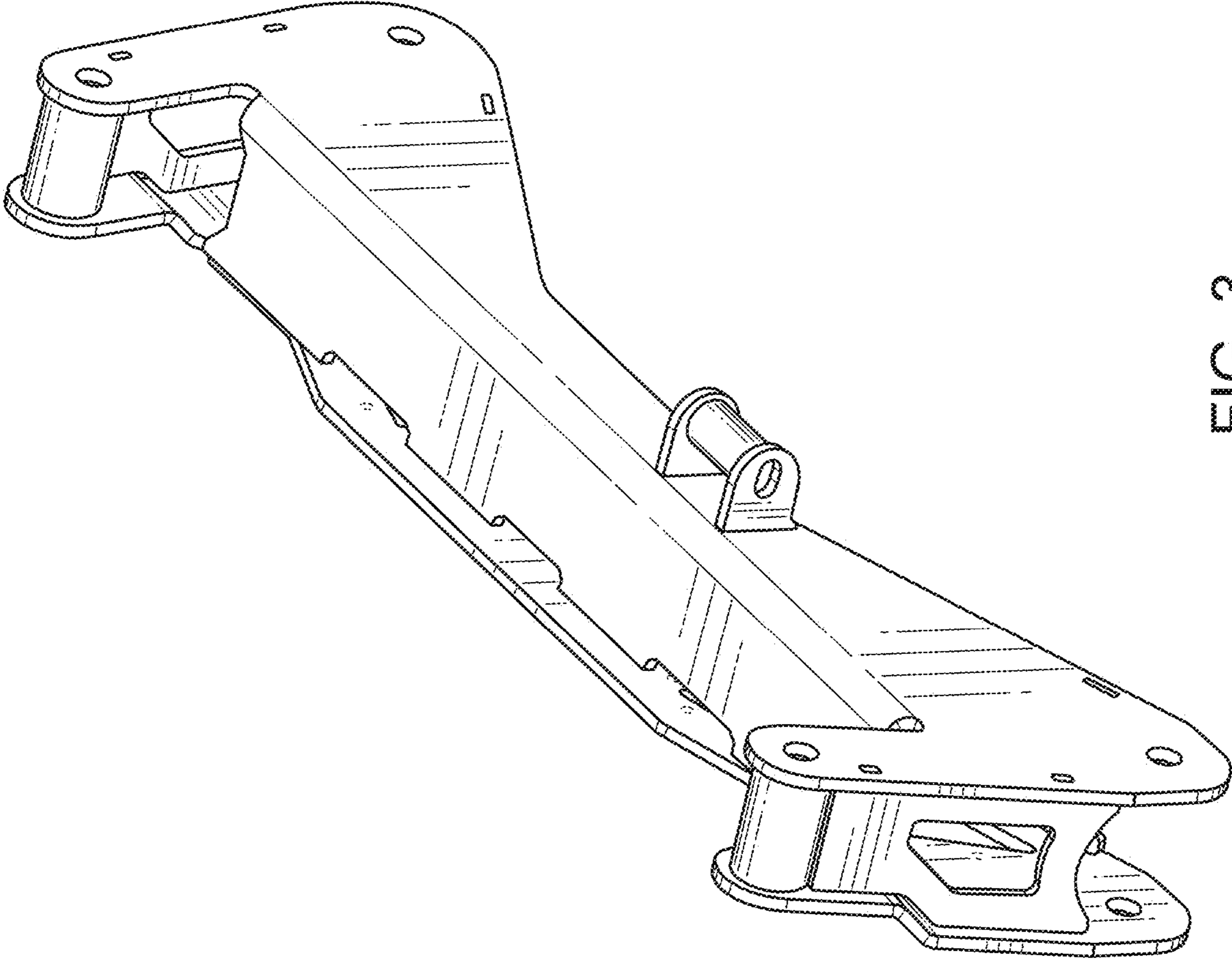

FIG. 3

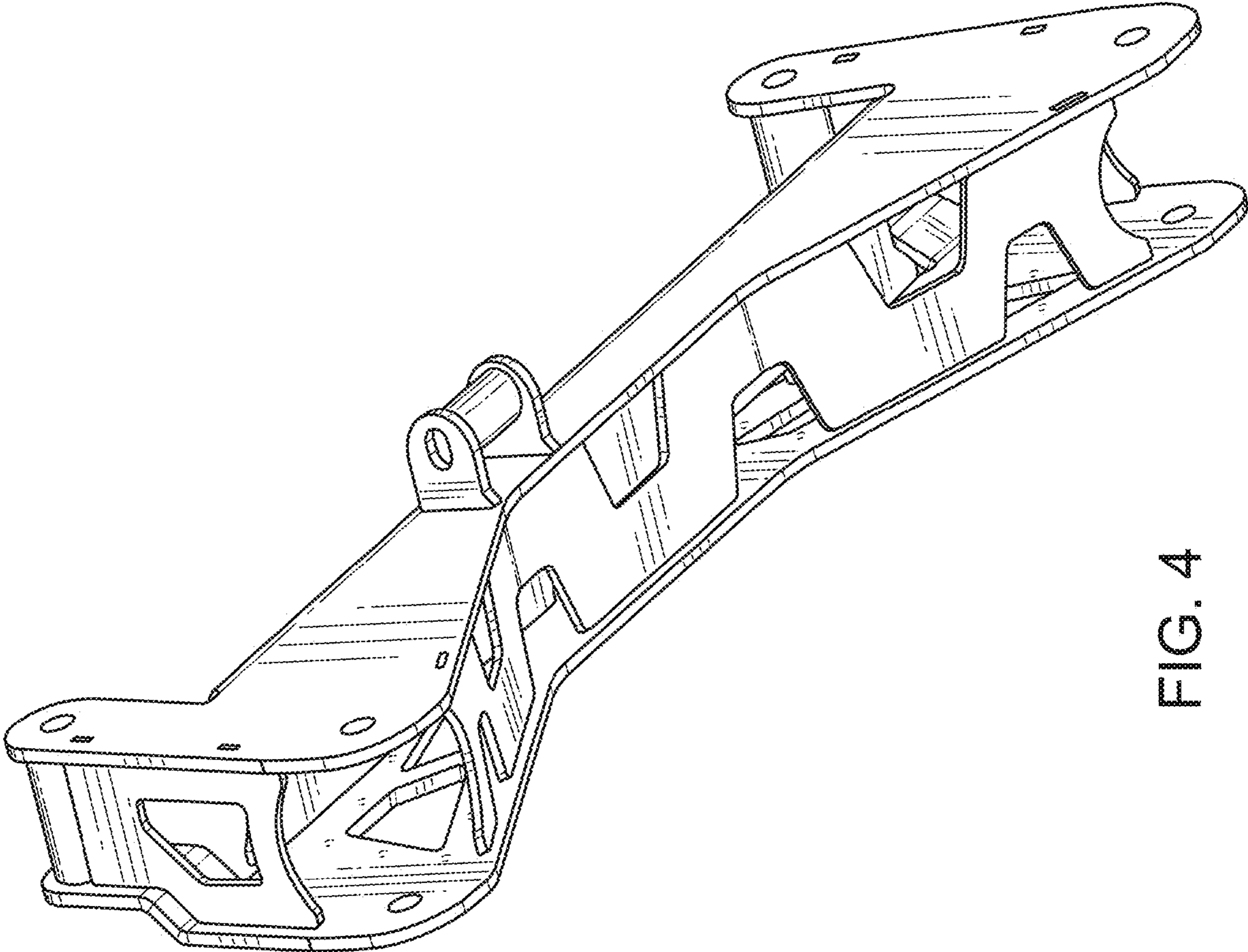

FIG. 4

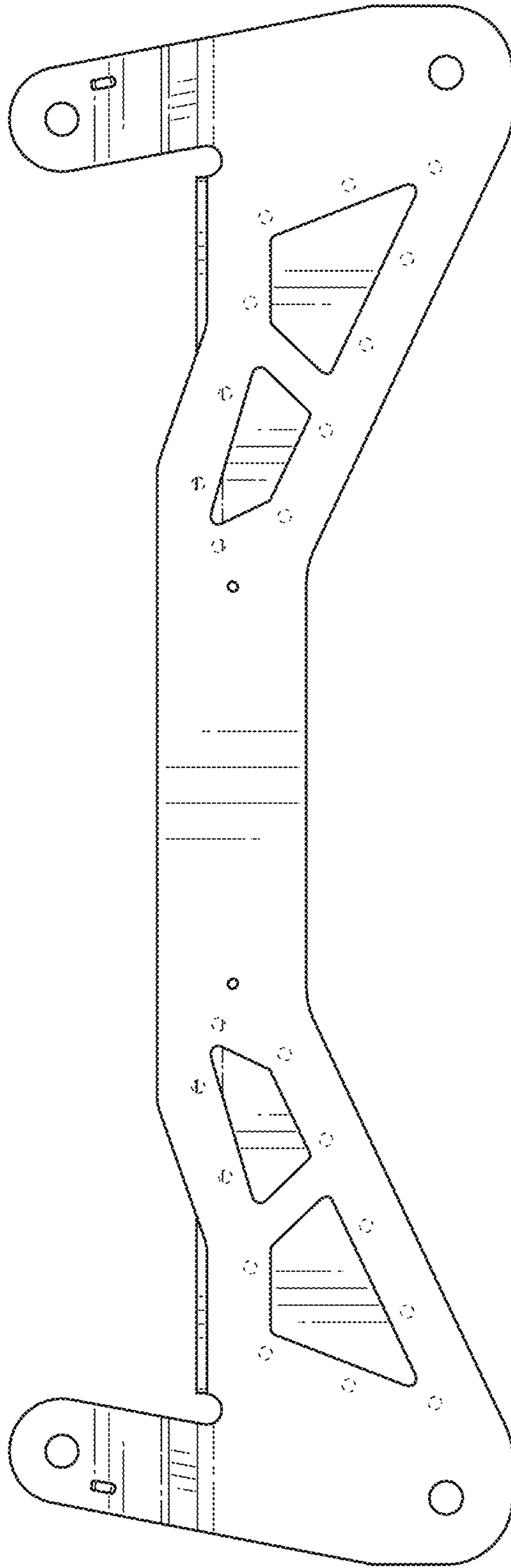

FIG. 5

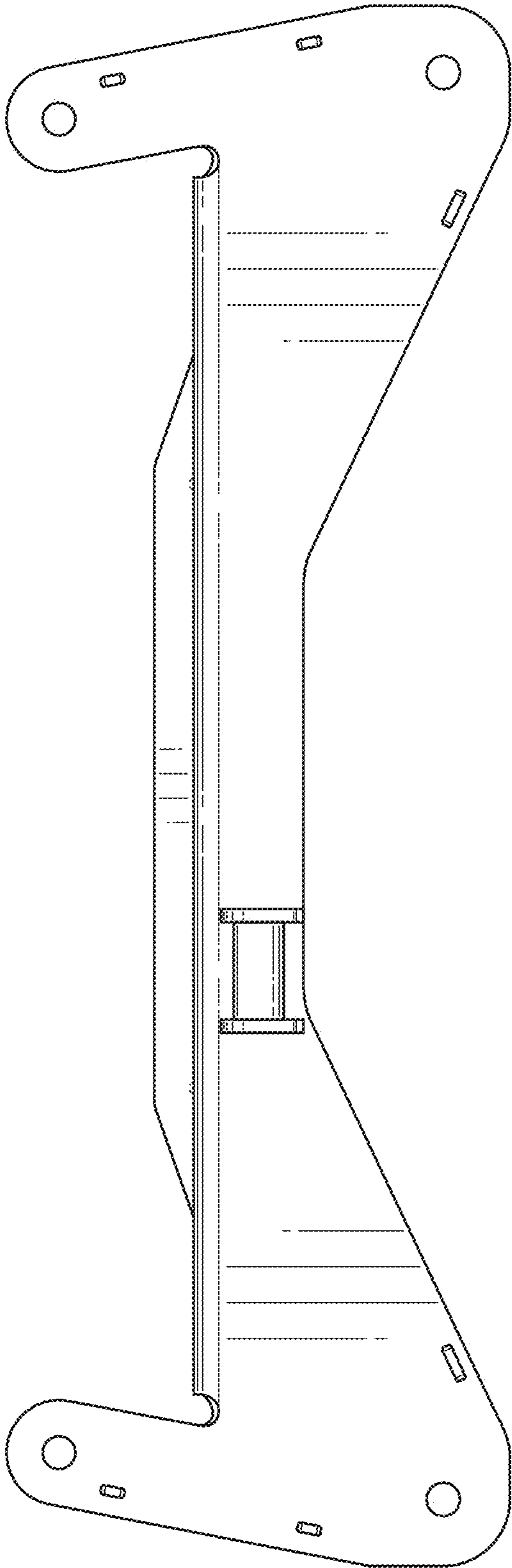

FIG. 6

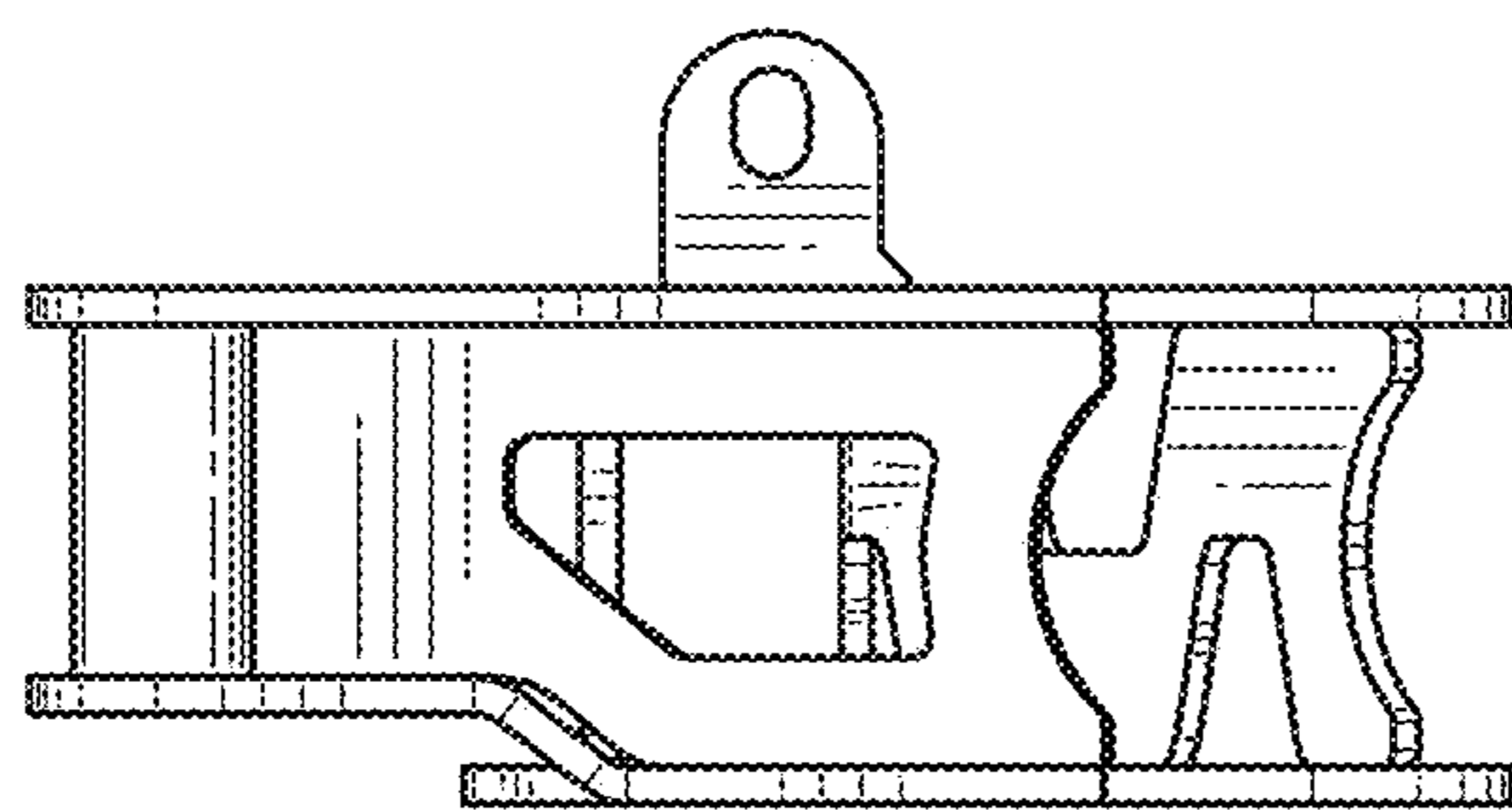

FIG. 7

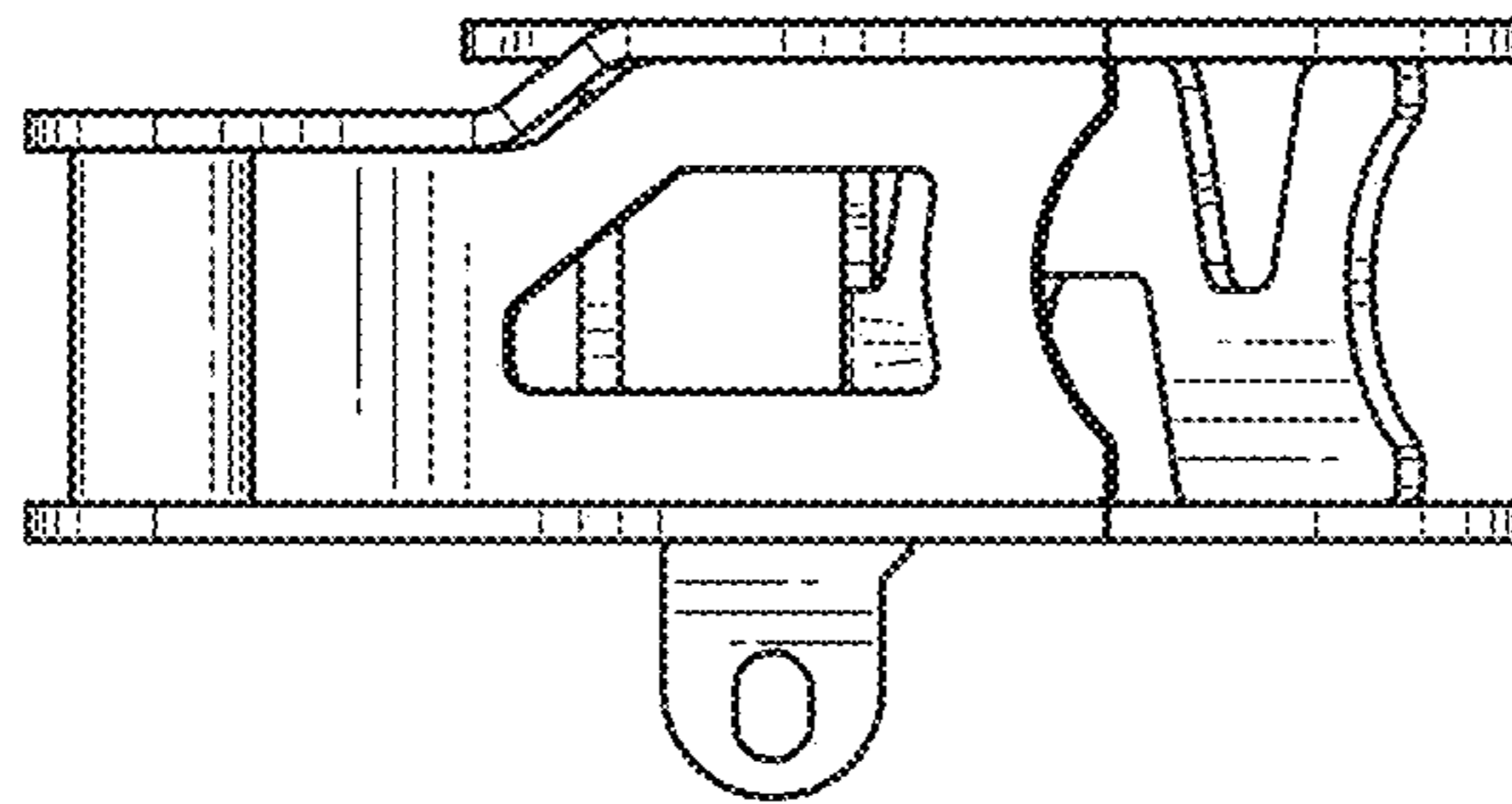

FIG. 8

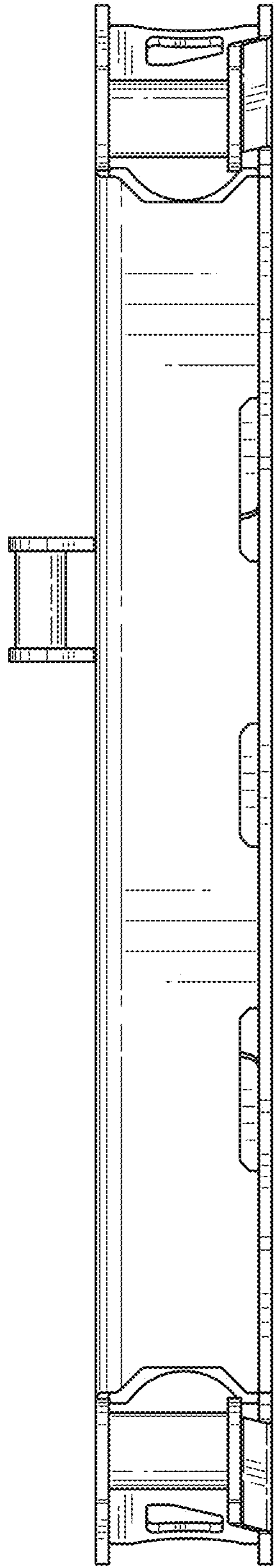

FIG. 9

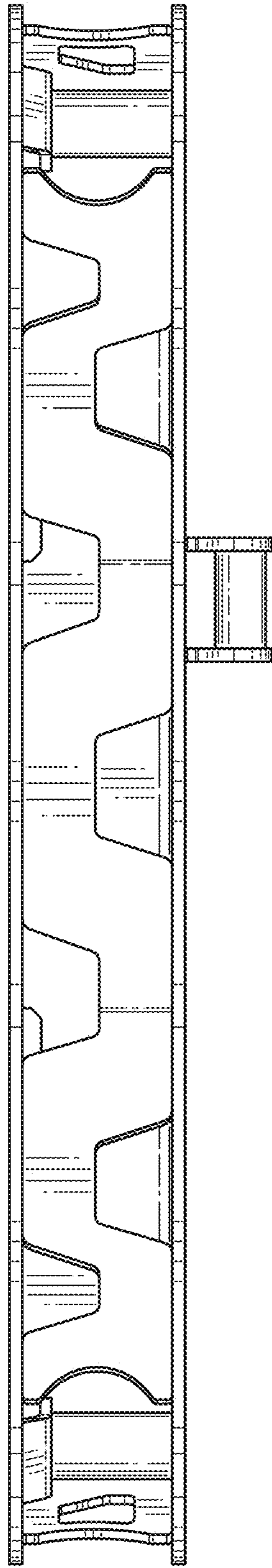

FIG. 10