



US00D949595S

(12) **United States Design Patent** (10) **Patent No.:** **US D949,595 S**
Buccola, Jr. et al. (45) **Date of Patent:** **** Apr. 26, 2022**

(54) **RAIL FOR BLINDS**
(71) Applicant: **Hunter Douglas, Inc.**, Pearl River, NY (US)
(72) Inventors: **Nickolas C. Buccola, Jr.**, Brighton, CO (US); **Stephen P. Smith**, Denver, CO (US)
(73) Assignee: **HUNTER DOUGLAS, INC.**, Pearl River, NY (US)

D229,493 S * 12/1973 Feakins D25/125
D294,867 S * 3/1988 Meshulam D25/119
D368,851 S * 4/1996 Cole D8/376
D412,753 S * 8/1999 Colson D25/48.4
D440,100 S * 4/2001 Horsten D6/580
D440,444 S * 4/2001 Sonnenberg D6/580
D443,457 S * 6/2001 Horsten D6/580
D473,663 S * 4/2003 Chou D25/122
D522,297 S * 6/2006 Miller D6/580
D530,967 S * 10/2006 Smith D6/580
D542,068 S * 5/2007 Watkins D6/580

(Continued)

(**) Term: **15 Years**

FOREIGN PATENT DOCUMENTS

(21) Appl. No.: **29/715,784**

CN 3671986 * 7/2007

(22) Filed: **Dec. 4, 2019**

Primary Examiner — Leanne Was-Englehart

(74) *Attorney, Agent, or Firm* — Leason Ellis LLP

Related U.S. Application Data

(62) Division of application No. 29/626,947, filed on Nov. 21, 2017, now Pat. No. Des. 872,501, which is a division of application No. 29/540,035, filed on Sep. 21, 2015, now Pat. No. Des. 806,439.

(57) **CLAIM**

We claim the ornamental design for a rail for blinds, as shown and described.

(51) **LOC (13) Cl.** **06-10**

(52) **U.S. Cl.** **D6/580**

(58) **Field of Classification Search**

USPC D6/575, 577, 579, 580; D8/349, 354, D8/363, 376, 377; D25/48.4, 48.7, 48.8, D25/60, 119–125, 136, 164

CPC . E06B 9/40; E06B 9/264; E06B 9/266; E06B 9/322; E06B 9/323; E06B 2009/2452; G02B 6/4459; G02B 6/4478

See application file for complete search history.

DESCRIPTION

FIG. 1 is a top front isometric view of a rail for blinds in accordance with the present design.

FIG. 2 is a front elevation view thereof.

FIG. 3 is a rear elevation view thereof.

FIG. 4 is a right side elevation view thereof.

FIG. 5 is a left side elevation view thereof.

FIG. 6 is a top plan view thereof; and,

FIG. 7 is a bottom plan view thereof.

The dash-dash broken lines illustrate portions of the rail for blinds that form no part of the claimed design. The dash-dot broken lines depicts the boundary of the claimed design; any portion of the article between the break lines forms no part of the claimed design.

The drawings contain symbolic break lines. The portion between the break lines forms no part of the claimed design.

(56) **References Cited**

U.S. PATENT DOCUMENTS

1,202,288 A * 10/1916 Hartshorn E06B 9/52
160/391
1,900,769 A * 3/1933 Schemmel B60R 13/04
52/716.6

1 Claim, 3 Drawing Sheets

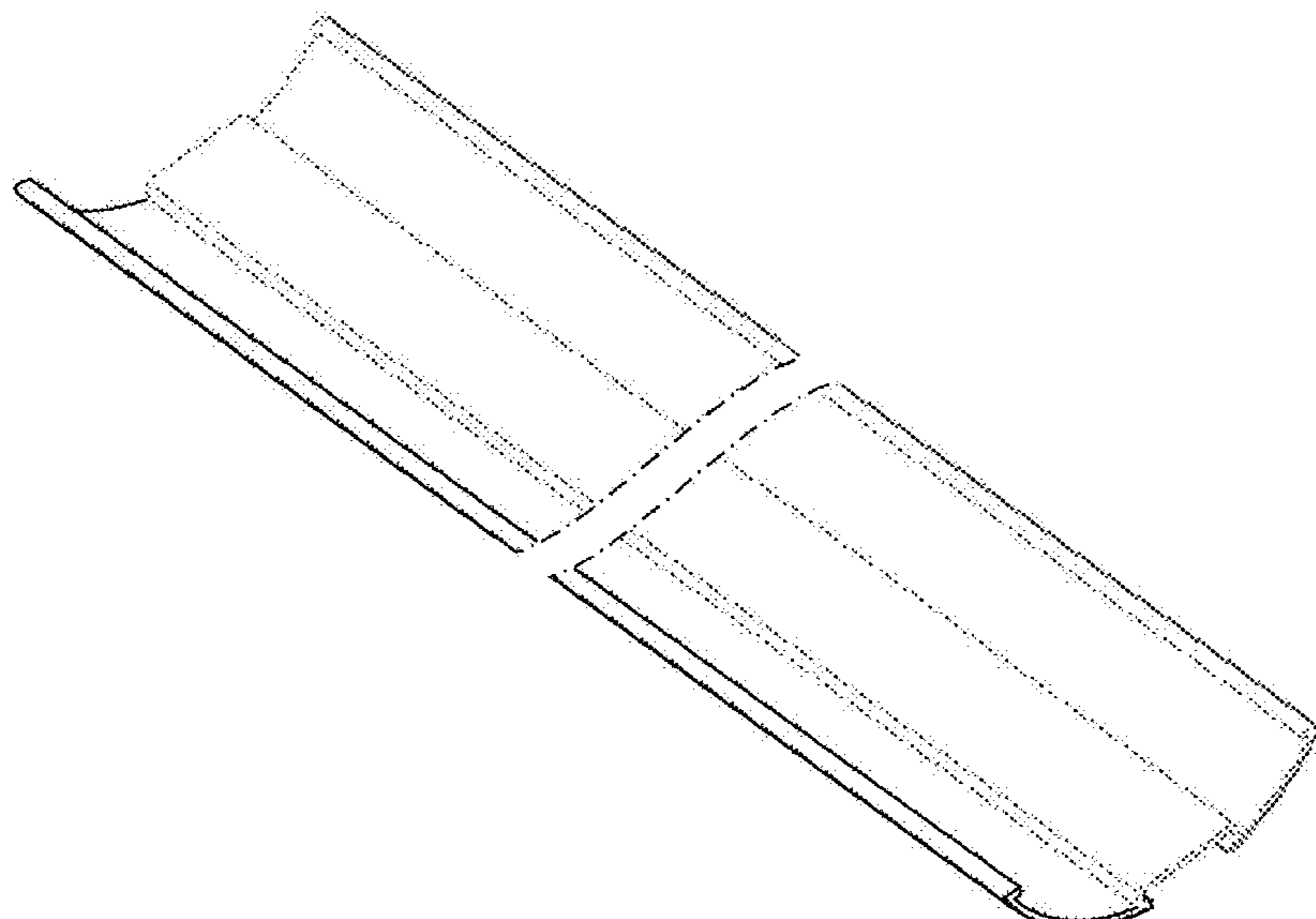

(56)

References Cited

U.S. PATENT DOCUMENTS

D546,104	S *	7/2007	Miller	D6/580
D601,274	S *	9/2009	Koenig, Jr.	D25/164
D633,320	S *	3/2011	Brace	D6/580
D647,629	S *	10/2011	Seehof	D25/41.1
D647,630	S *	10/2011	Seehof	D25/41.1
D649,686	S *	11/2011	Trzesniowski	D26/138
D675,750	S *	2/2013	King	D25/122
D677,405	S *	3/2013	Landis	D25/121
D680,357	S *	4/2013	Wills	D6/580
D750,276	S *	2/2016	Hicks	D25/48.4
D762,462	S *	8/2016	Anderson	D8/377
9,410,371	B2 *	8/2016	Faller	E06B 9/322
D772,435	S *	11/2016	Bonuccelli	D25/122
D774,210	S *	12/2016	Schanz	D25/48.4
D806,439	S *	1/2018	Buccola, Jr.	D6/580
10,174,551	B2 *	1/2019	Buccola, Jr.	E06B 9/34
10,487,572	B2 *	11/2019	Smith	E06B 9/322
D872,501	S *	1/2020	Buccola, Jr.	D6/580
D874,184	S *	2/2020	Chou	D6/580
D909,618	S *	2/2021	Zhao	D25/121
2002/0046816	A1 *	4/2002	Judkins	E06B 9/323
					160/32
2008/0149280	A1 *	6/2008	Smith	E06B 9/262
					160/121.1
2011/0056630	A1 *	3/2011	Buccola, Jr.	E06B 9/36
					160/168.1 V
2014/0262068	A1 *	9/2014	Buccola, Jr.	E06B 9/322
					160/120
2016/0130866	A1 *	5/2016	Buccola, Jr.	E06B 9/62
					185/9
2017/0081915	A1 *	3/2017	Buccola, Jr.	E06B 9/367
2017/0211322	A1 *	7/2017	Smith	E06B 9/322
2018/0371834	A1 *	12/2018	Watkins	E06B 9/322

* cited by examiner

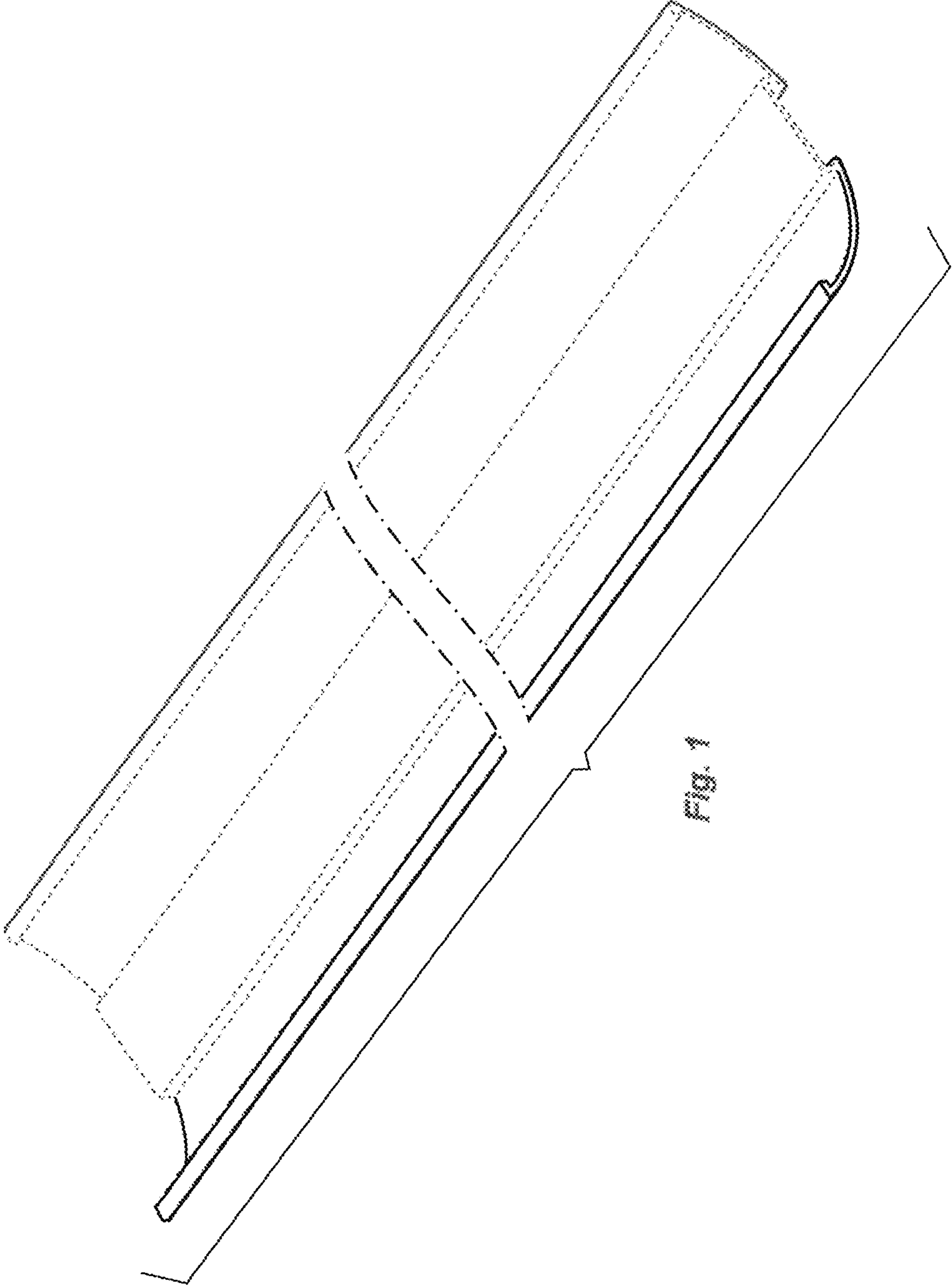

Fig. 1

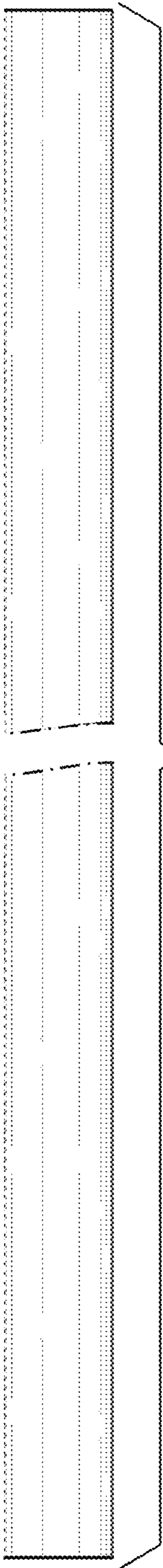

Fig. 2

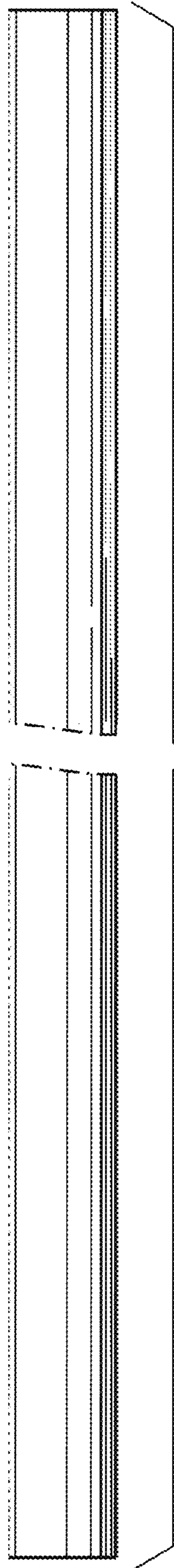

Fig. 3



Fig. 4



Fig. 5

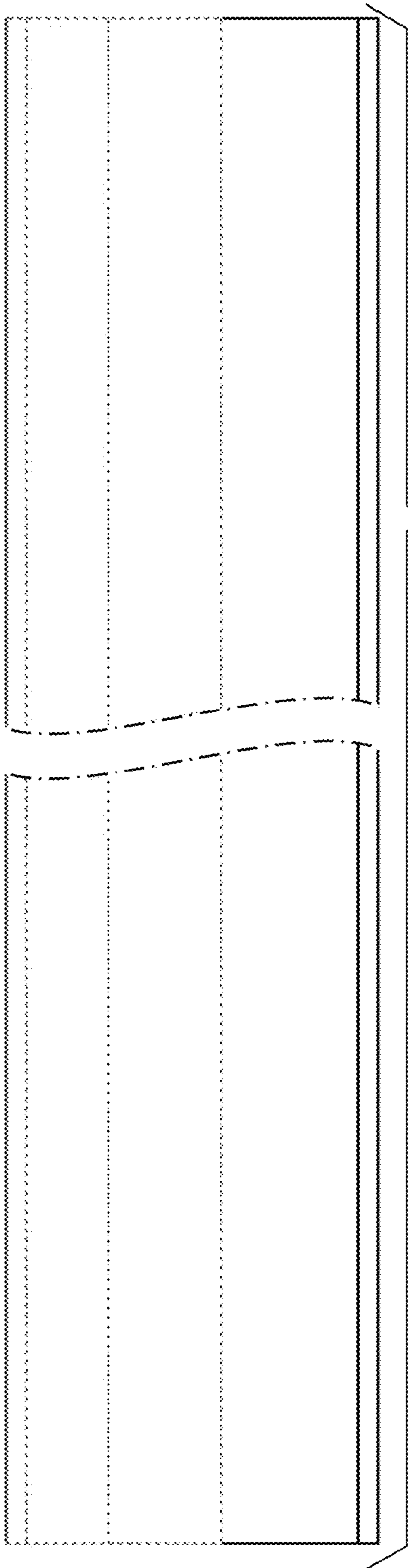

Fig. 6

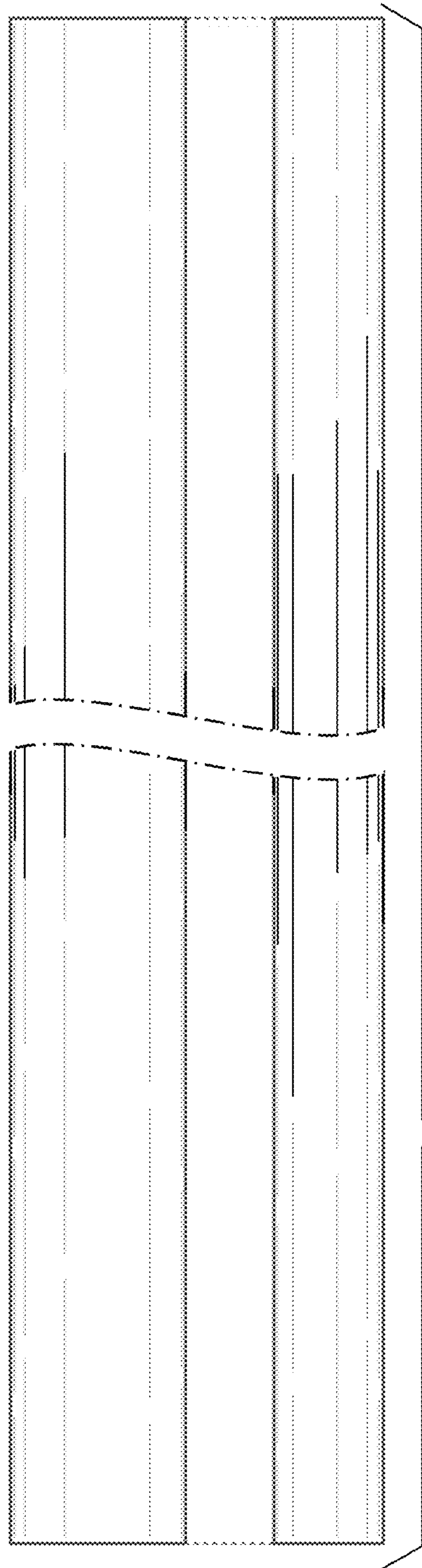

Fig. 7