



US00D949384S

(12) **United States Design Patent** (10) **Patent No.:** **US D949,384 S**  
**Liang** (45) **Date of Patent:** **\*\* Apr. 19, 2022**

(54) **HAND-HELD MASSAGER**  
(71) Applicant: **SHENZHEN CREATE FUTURE INTERNATIONAL TRADING COMPANY, Shenzhen (CN)**  
(72) Inventor: **Tingting Liang, Nanyang (CN)**  
(73) Assignee: **SHENZHEN CREATE FUTURE INTERNATIONAL TRADING COMPANY, Shenzhen (CN)**  
(\*\*) Term: **15 Years**  
(21) Appl. No.: **29/720,685**  
(22) Filed: **Jan. 15, 2020**  
(51) **LOC (13) Cl.** ..... **28-03**  
(52) **U.S. Cl.**  
USPC ..... **D24/215**  
(58) **Field of Classification Search**  
USPC ..... D24/200, 211, 212, 213, 214, 215;  
D8/14.1; D28/13, 44.1  
CPC ..... A61H 2201/1635; A61H 23/006; A61H  
1/00; A61H 15/02; A61H 1/008  
See application file for complete search history.

D879,986 S \* 3/2020 Wersland ..... D24/214  
D880,714 S \* 4/2020 Wersland ..... D24/215  
D880,715 S \* 4/2020 Wersland ..... D24/215  
D880,716 S \* 4/2020 Wersland ..... D24/215  
D884,205 S \* 5/2020 Zhuang ..... D24/215  
(Continued)

(56) **References Cited**  
U.S. PATENT DOCUMENTS  
D616,558 S \* 5/2010 Tsai ..... D24/200  
D808,076 S \* 1/2018 Gabriele ..... D28/44.1  
D844,896 S \* 4/2019 Levi ..... D28/44.1  
D847,362 S \* 4/2019 Tang ..... D24/215  
D847,364 S \* 4/2019 Lee ..... D24/215  
10,314,762 B1 \* 6/2019 Marton ..... A61H 23/006  
D855,822 S \* 8/2019 Marton ..... D24/215  
D863,571 S \* 10/2019 Yang ..... D24/200  
D866,790 S \* 11/2019 Lee ..... D24/215  
D872,869 S \* 1/2020 Lu ..... D24/215  
D873,432 S \* 1/2020 Duan ..... D24/214  
D874,015 S \* 1/2020 Marton ..... D24/215  
D875,961 S \* 2/2020 Li ..... D24/211  
D877,351 S \* 3/2020 Wersland ..... D24/215  
D879,985 S \* 3/2020 Wersland ..... D24/214

**OTHER PUBLICATIONS**

Amazon, "EveryMile Muscle Massage Gun", Dec. 20, 2020. [https://www.amazon.com/EveryMile-Muscle-Massage-Gun-Adjustable/dp/B0875TS1FF/ref=sr\\_1\\_151?dchild=1&keywords=Voltacious+Recovery+%E2%84%A2+Percussion+Massage+Gun&qid=1630176900&sr=8-151](https://www.amazon.com/EveryMile-Muscle-Massage-Gun-Adjustable/dp/B0875TS1FF/ref=sr_1_151?dchild=1&keywords=Voltacious+Recovery+%E2%84%A2+Percussion+Massage+Gun&qid=1630176900&sr=8-151). Shown on p. 1. (Year: 2020).\*

*Primary Examiner* — Michael A Maharajh  
(74) *Attorney, Agent, or Firm* — Li & Cai Intellectual Property (USA) Office

(57) **CLAIM**  
The ornamental design for a hand-held massager, as shown and described.

**DESCRIPTION**

FIG. 1 is a front, top and right perspective view of a hand-held massager showing my new design;  
FIG. 2 is a front elevational view thereof;  
FIG. 3 is a rear elevational view thereof;  
FIG. 4 is a left side elevational view thereof;  
FIG. 5 is a right side elevational view thereof;  
FIG. 6 is a top plan view thereof;  
FIG. 7 is a bottom plan view thereof; and,  
FIG. 8 is a front, top and left perspective view of the hand-held massager depicting a ball assembly in an attached position.  
The broken lines depict portions of the hand-held massager in which the design is embodied that forms no part of the claimed design.  
The broken lines of the ball assembly shown in FIG. 8 are for the purpose of illustrating environmental structure, which form no part of the claimed design.

**1 Claim, 6 Drawing Sheets**

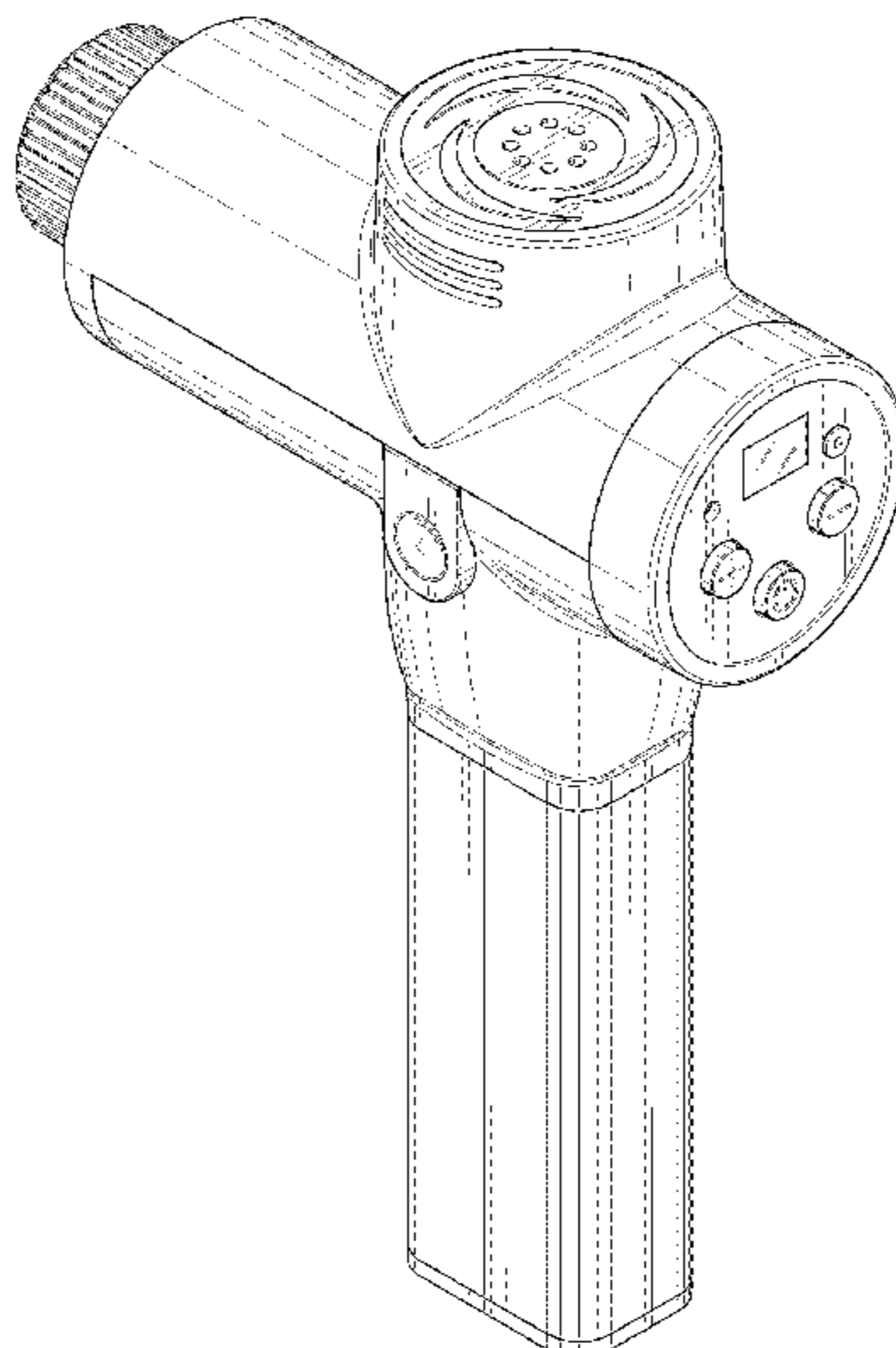

(56)

References Cited

U.S. PATENT DOCUMENTS

D884,207 S \* 5/2020 Ma ..... D24/215  
 D884,915 S \* 5/2020 Wersland ..... D24/215  
 D885,601 S \* 5/2020 Wersland ..... D24/215  
 D886,317 S \* 6/2020 Marton ..... D24/215  
 D887,573 S \* 6/2020 Wersland ..... D24/215  
 10,714,953 B1 \* 7/2020 Solana ..... H02J 7/0044  
 D893,738 S \* 8/2020 Zhuang ..... D24/215  
 D895,132 S \* 9/2020 Hu ..... D24/215  
 D895,133 S \* 9/2020 Xu ..... D24/215  
 D895,135 S \* 9/2020 Xu ..... D24/215  
 D895,829 S \* 9/2020 Hu ..... D24/215  
 D895,831 S \* 9/2020 Chen ..... D24/215  
 D896,396 S \* 9/2020 Wersland ..... D24/215  
 D898,209 S \* 10/2020 Xu ..... D24/214  
 D898,933 S \* 10/2020 Xu ..... D24/215  
 D899,620 S \* 10/2020 Huang ..... D24/215  
 D900,329 S \* 10/2020 Xu ..... D24/215  
 D905,863 S \* 12/2020 Lin ..... D24/215  
 D906,533 S \* 12/2020 Xu ..... D24/215  
 D907,229 S \* 1/2021 Zhang ..... D24/215  
 D907,230 S \* 1/2021 Zhang ..... D24/215  
 D908,908 S \* 1/2021 Xu ..... D24/215  
 D910,194 S \* 2/2021 Radtke ..... D24/215  
 D911,535 S \* 2/2021 Yu ..... D24/200  
 D912,267 S \* 3/2021 Tang ..... D24/215  
 D912,268 S \* 3/2021 Xiang ..... D24/215  
 D912,835 S \* 3/2021 Ren ..... D24/200  
 D913,516 S \* 3/2021 Zhang ..... D24/215  
 D913,517 S \* 3/2021 Yu ..... D24/215  
 D914,966 S \* 3/2021 Kim ..... D28/13  
 10,940,081 B2 \* 3/2021 Nazarian ..... A61H 23/006  
 10,959,911 B2 \* 3/2021 Wersland ..... A61H 1/00  
 D916,307 S \* 4/2021 Xiong ..... D24/215  
 D917,060 S \* 4/2021 Hu ..... D24/215  
 D918,408 S \* 5/2021 Huang ..... D24/215  
 10,993,874 B1 \* 5/2021 Marton ..... A61H 23/02

D921,215 S \* 6/2021 Xu ..... D24/215  
 D921,914 S \* 6/2021 Wersland ..... D24/214  
 D921,916 S \* 6/2021 Xu ..... D24/215  
 D921,917 S \* 6/2021 Xu ..... D24/215  
 D923,187 S \* 6/2021 Ma ..... D24/211  
 D923,188 S \* 6/2021 Xu ..... D24/211  
 D923,190 S \* 6/2021 Xu ..... D24/214  
 D923,194 S \* 6/2021 Xu ..... D24/215  
 D924,422 S \* 7/2021 Huang ..... D24/215  
 D924,425 S \* 7/2021 Grbic ..... D24/215  
 D925,751 S \* 7/2021 Wu ..... D24/211  
 D925,755 S \* 7/2021 Zheng ..... D24/215  
 D925,756 S \* 7/2021 Xu ..... D24/215  
 D925,758 S \* 7/2021 Xu ..... D24/215  
 D926,333 S \* 7/2021 Zhang ..... D24/215  
 D926,335 S \* 7/2021 Zhang ..... D24/215  
 D926,338 S \* 7/2021 Xu ..... D24/215  
 D927,714 S \* 8/2021 Li ..... D24/215  
 D927,715 S \* 8/2021 Li ..... D24/215  
 2015/0282878 A1 \* 10/2015 Kindermann ..... A61B 18/18  
 606/9  
 2016/0338899 A1 \* 11/2016 Howson ..... A61H 7/001  
 2016/0367425 A1 \* 12/2016 Wersland ..... A61H 1/008  
 2017/0079865 A1 \* 3/2017 Kao ..... A61H 1/008  
 2017/0304145 A1 \* 10/2017 Pepe ..... A61H 23/006  
 2018/0200141 A1 \* 7/2018 Wersland ..... A61H 15/0085  
 2019/0254921 A1 \* 8/2019 Marton ..... A61H 23/0254  
 2020/0069510 A1 \* 3/2020 Wersland ..... A61H 23/006  
 2020/0085675 A1 \* 3/2020 Lee ..... A61H 1/00  
 2020/0214930 A1 \* 7/2020 Wersland ..... A61H 1/00  
 2020/0261306 A1 \* 8/2020 Pepe ..... A61H 23/0254  
 2020/0261307 A1 \* 8/2020 Wersland ..... A61H 23/006  
 2020/0268594 A1 \* 8/2020 Pepe ..... A61H 15/02  
 2020/0390644 A1 \* 12/2020 Yang ..... A61H 15/00  
 2020/0405574 A1 \* 12/2020 Wersland ..... A61H 1/008  
 2021/0022955 A1 \* 1/2021 Wersland ..... A61H 15/0085  
 2021/0059898 A1 \* 3/2021 Wersland ..... A61H 15/00  
 2021/0113427 A1 \* 4/2021 Liu ..... A61H 23/0254

\* cited by examiner



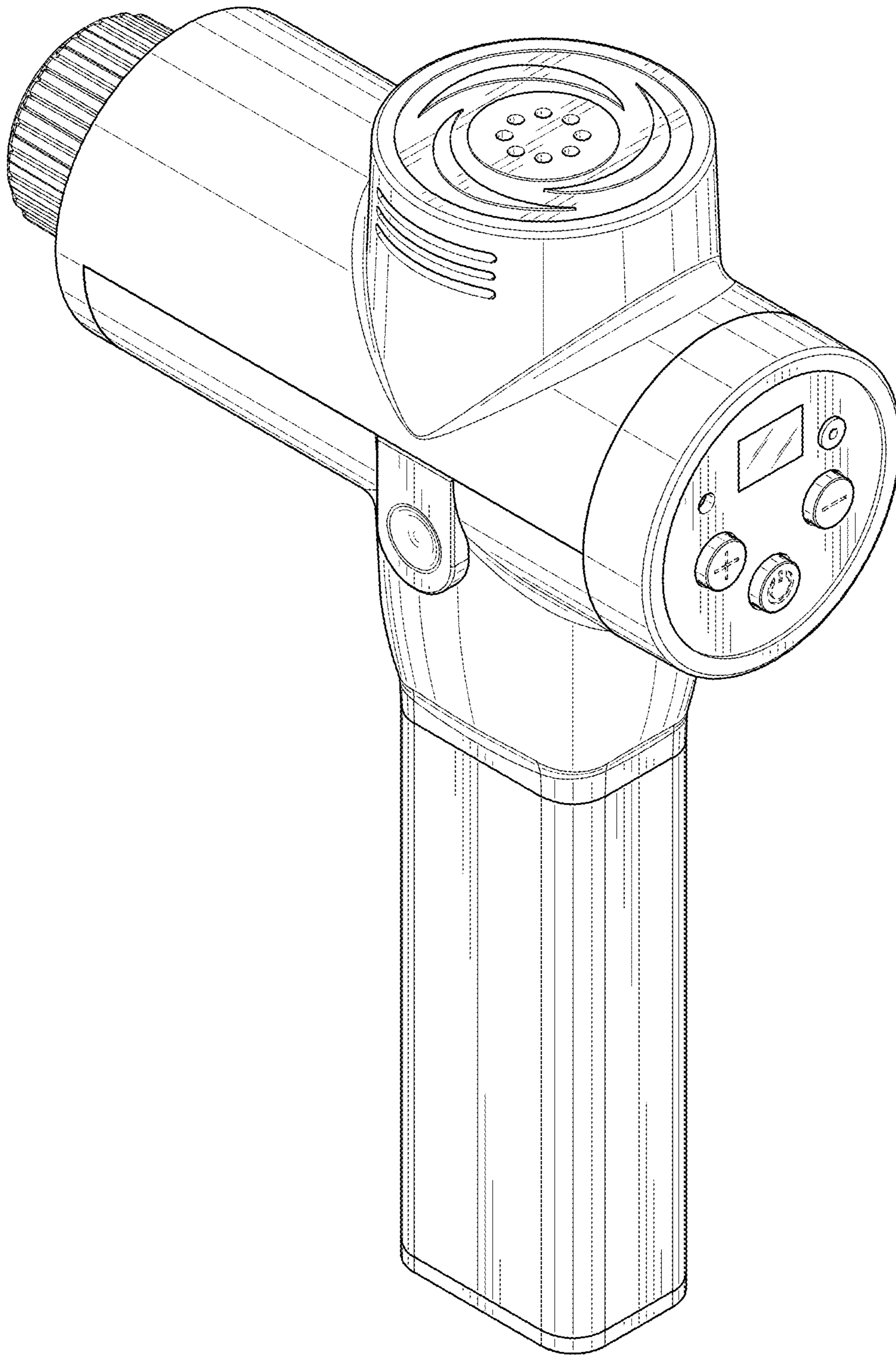

FIG. 1

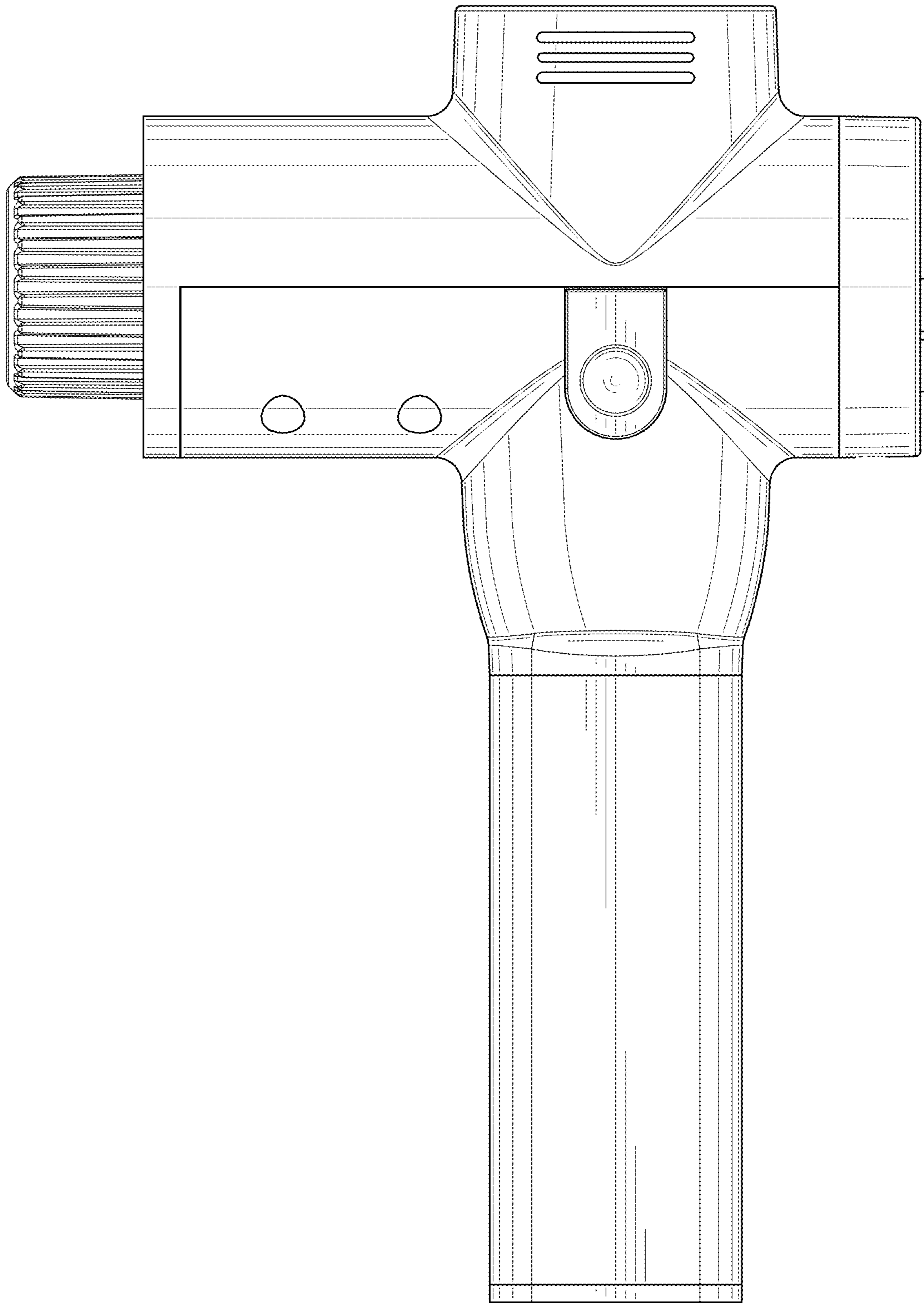

FIG. 2



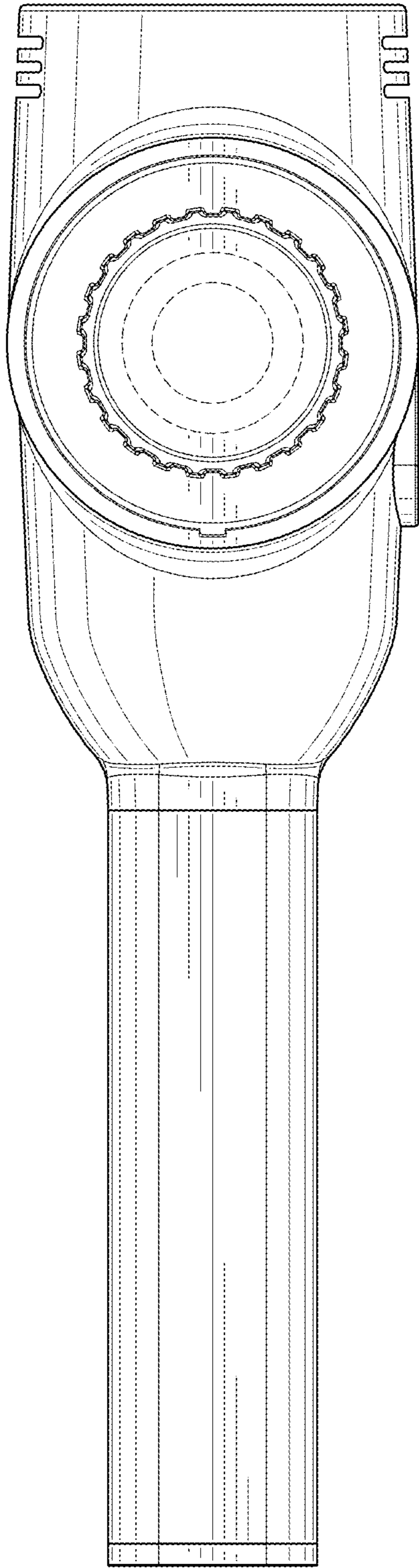

FIG. 4

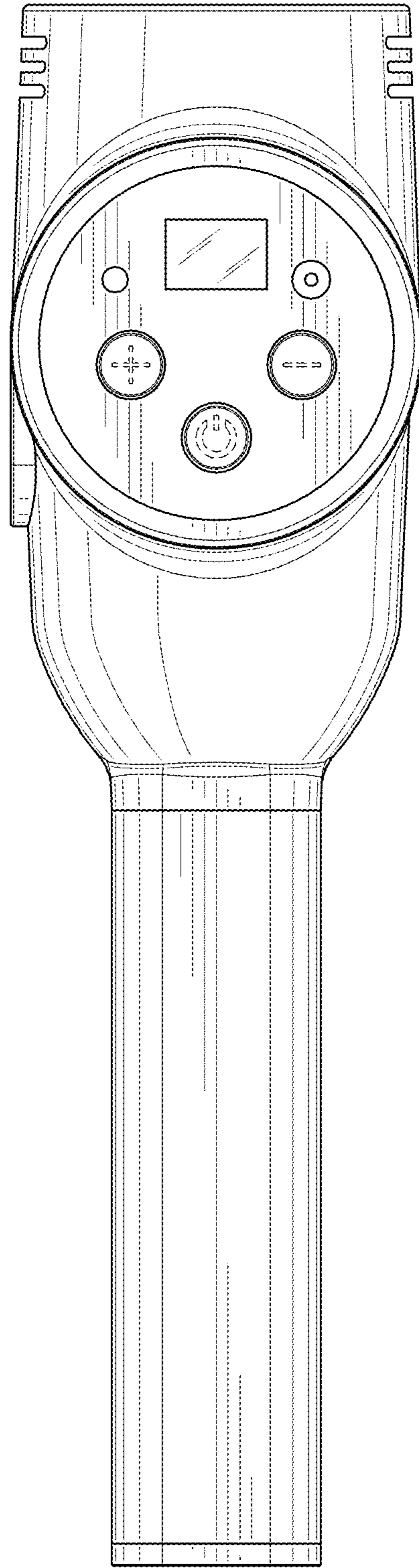

FIG. 5



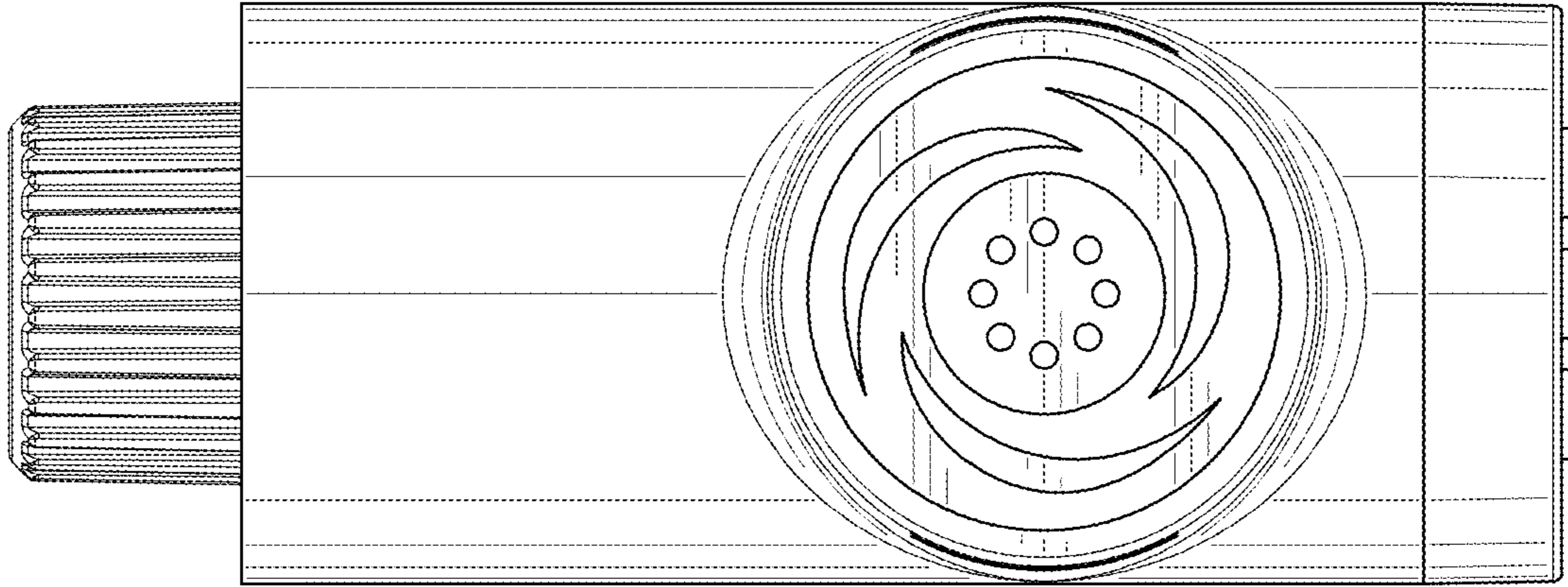

FIG. 6

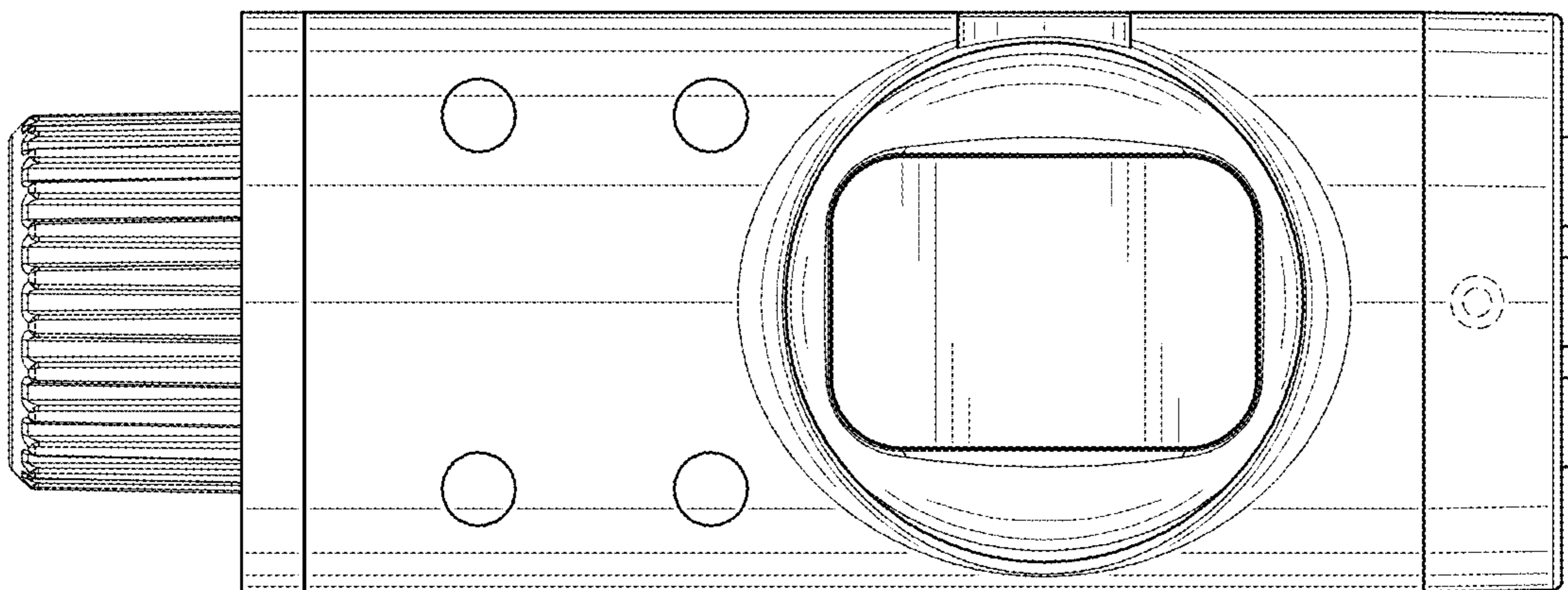

FIG. 7

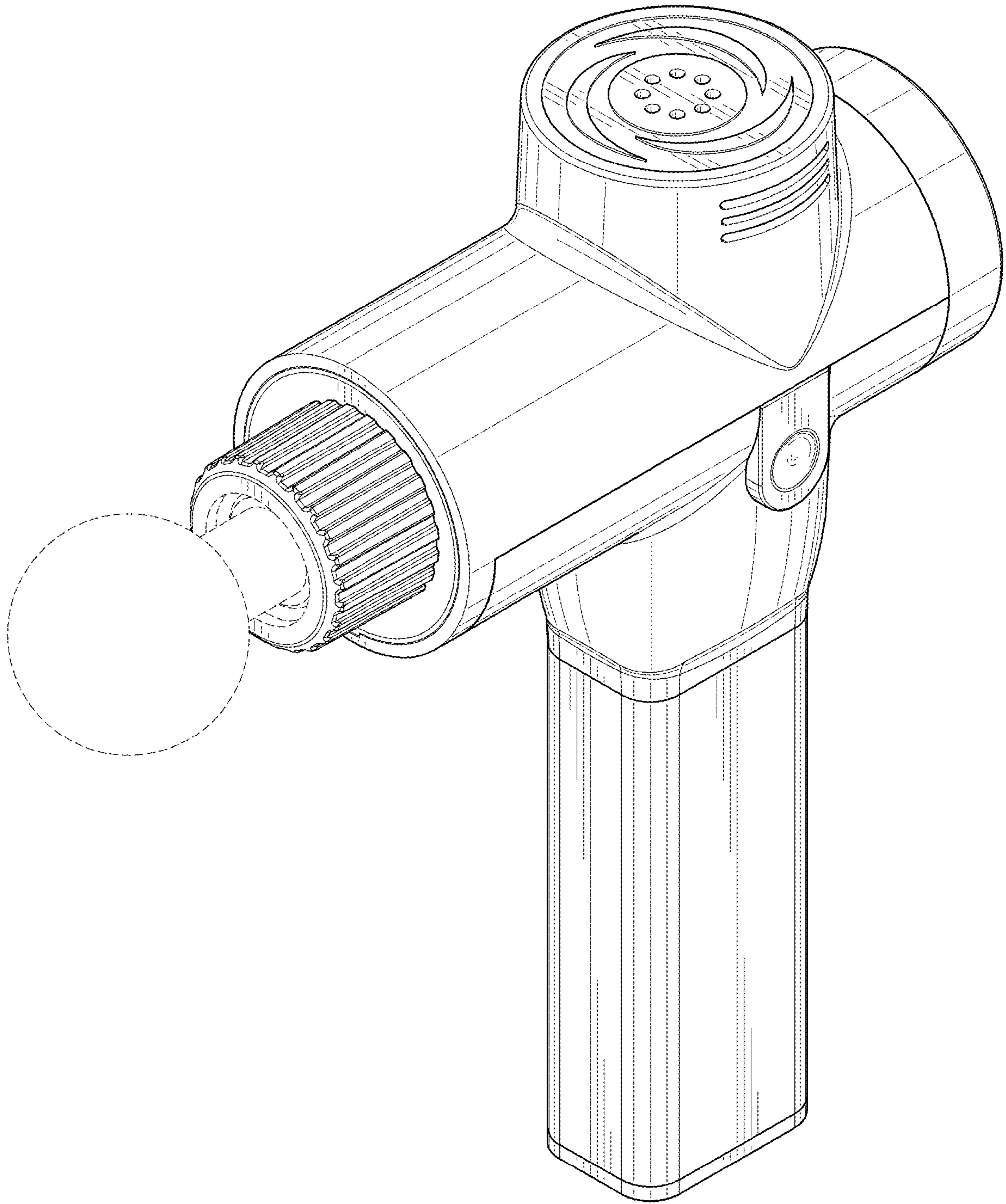

FIG. 8