



US00D949217S

(12) **United States Design Patent** (10) **Patent No.:** **US D949,217 S**  
**Srivastava et al.** (45) **Date of Patent:** **\*\* Apr. 19, 2022**

(54) **INDUCTION STATION MODULE**  
(71) Applicant: **Grey Orange Pte. Ltd.**, Singapore (SG)  
(72) Inventors: **Varun Srivastava**, New Delhi (IN); **Mohit Kumar**, Merrut (IN); **Gnanaprakash Muthusamy**, Coimbatore (IN); **Subhash Chander**, Faridabad (IN)  
(73) Assignee: **GREY ORANGE PTE. LTD.**, Singapore (SG)  
(\*\*) Term: **15 Years**  
(21) Appl. No.: **29/726,917**  
(22) Filed: **Mar. 6, 2020**  
(51) **LOC (13) Cl.** ..... **15-99**  
(52) **U.S. Cl.**  
USPC ..... **D15/145**; D15/199  
(58) **Field of Classification Search**  
USPC .... D15/123, 124, 125, 141, 144-144.2, 145, D15/147, 199; D32/1, 2, 8, 10; D24/185, 231; D34/12, 19, 20; D7/667, D7/668  
CPC ..... D21H 27/002; D21F 11/145; D21F 5/181; D21F 13/00; B24C 9/00; B01F 5/06; B08B 15/02; B07B 1/22; B05C 15/00  
See application file for complete search history.

D409,810 S \* 5/1999 Ambrose ..... D34/20  
D615,110 S \* 5/2010 Flory ..... D15/145  
D615,112 S \* 5/2010 Awada ..... D15/199  
D707,737 S \* 6/2014 Craaford ..... D15/147  
D729,857 S \* 5/2015 Hynek ..... D15/199  
D822,083 S \* 7/2018 De Padova ..... D15/144  
D908,152 S \* 1/2021 Cacioppo ..... D15/199  
D923,903 S \* 6/2021 Shane ..... D34/19  
2007/0034613 A1 \* 2/2007 Lundberg ..... B23K 26/0876  
219/121.68  
2021/0195703 A1 \* 6/2021 Zoller ..... H05B 6/38

**OTHER PUBLICATIONS**

GreyOrange, "GreyMatter & Ranger robots", (uploaded on Apr. 11, 2020), YouTube.com, Article visible at the 2:00/2:57 mark of the video, URL:<https://www.youtube.com/watch?v=MQzNTugc3oM&t=121s> (Year: 2020).\*

\* cited by examiner

*Primary Examiner* — Calvin E Vansant  
*Assistant Examiner* — Mark T. Philipps  
(74) *Attorney, Agent, or Firm* — Ziegler IP Law Group, LLC

(57) **CLAIM**

The ornamental design for an induction station module, as shown and described.

**DESCRIPTION**

FIG. 1 is a front perspective view of an induction station module showing the new design.  
FIG. 2 is a front view thereof;  
FIG. 3 is a rear view thereof;  
FIG. 4 is a right side view thereof;  
FIG. 5 is a left side view thereof; and,  
FIG. 6 is a top view thereof.  
The portions of the article shown in broken lines form no part of the claimed design.

**1 Claim, 6 Drawing Sheets**

(56) **References Cited**  
U.S. PATENT DOCUMENTS

D172,029 S \* 4/1954 Johnson ..... D15/145  
D281,363 S \* 11/1985 Carvel ..... D34/14  
4,601,637 A \* 7/1986 Aviles ..... B25J 15/0475  
269/281  
D294,761 S \* 3/1988 Gallery ..... D34/20  
D328,307 S \* 7/1992 Belletire ..... D15/145  
D377,496 S \* 1/1997 Poole ..... D15/145

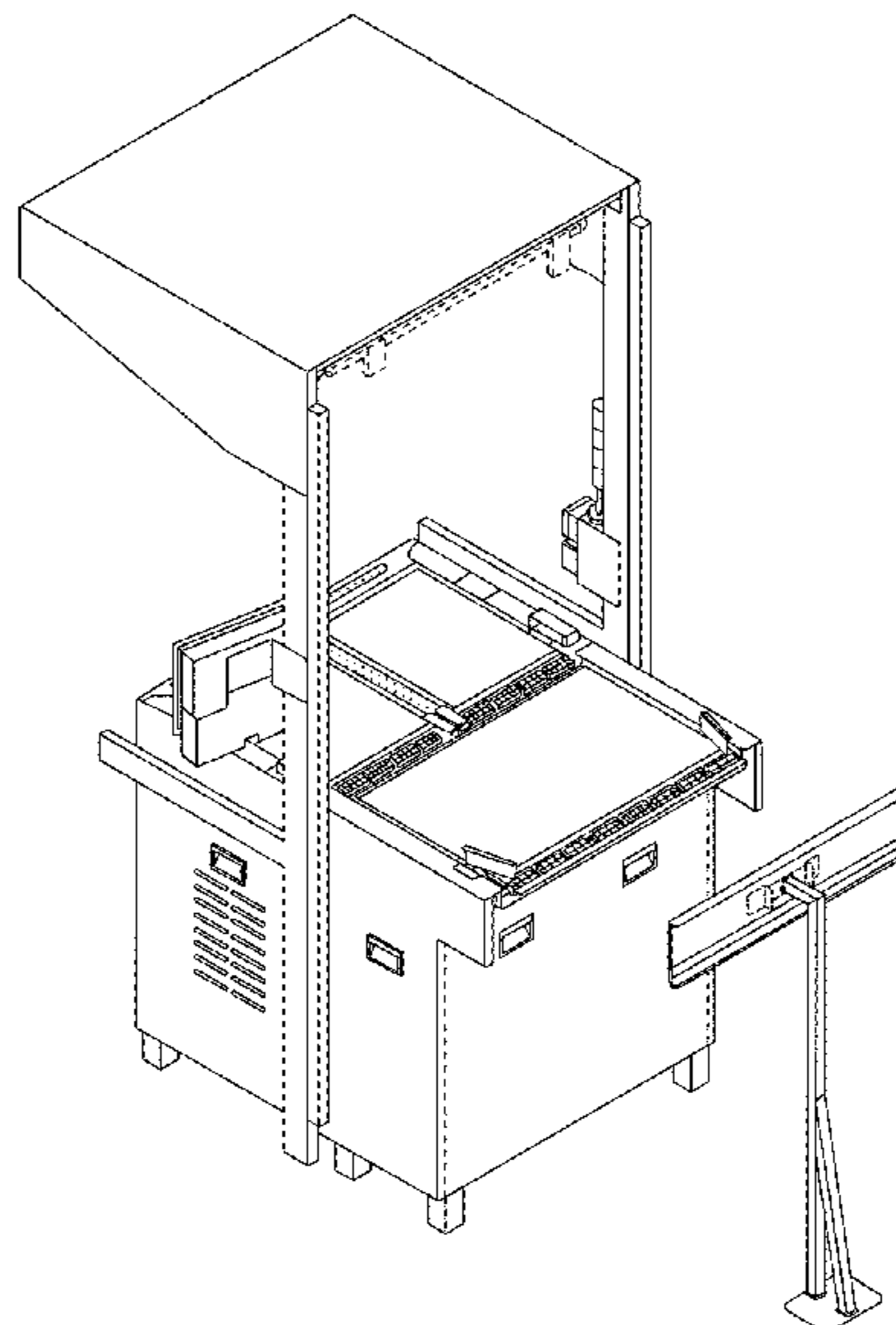

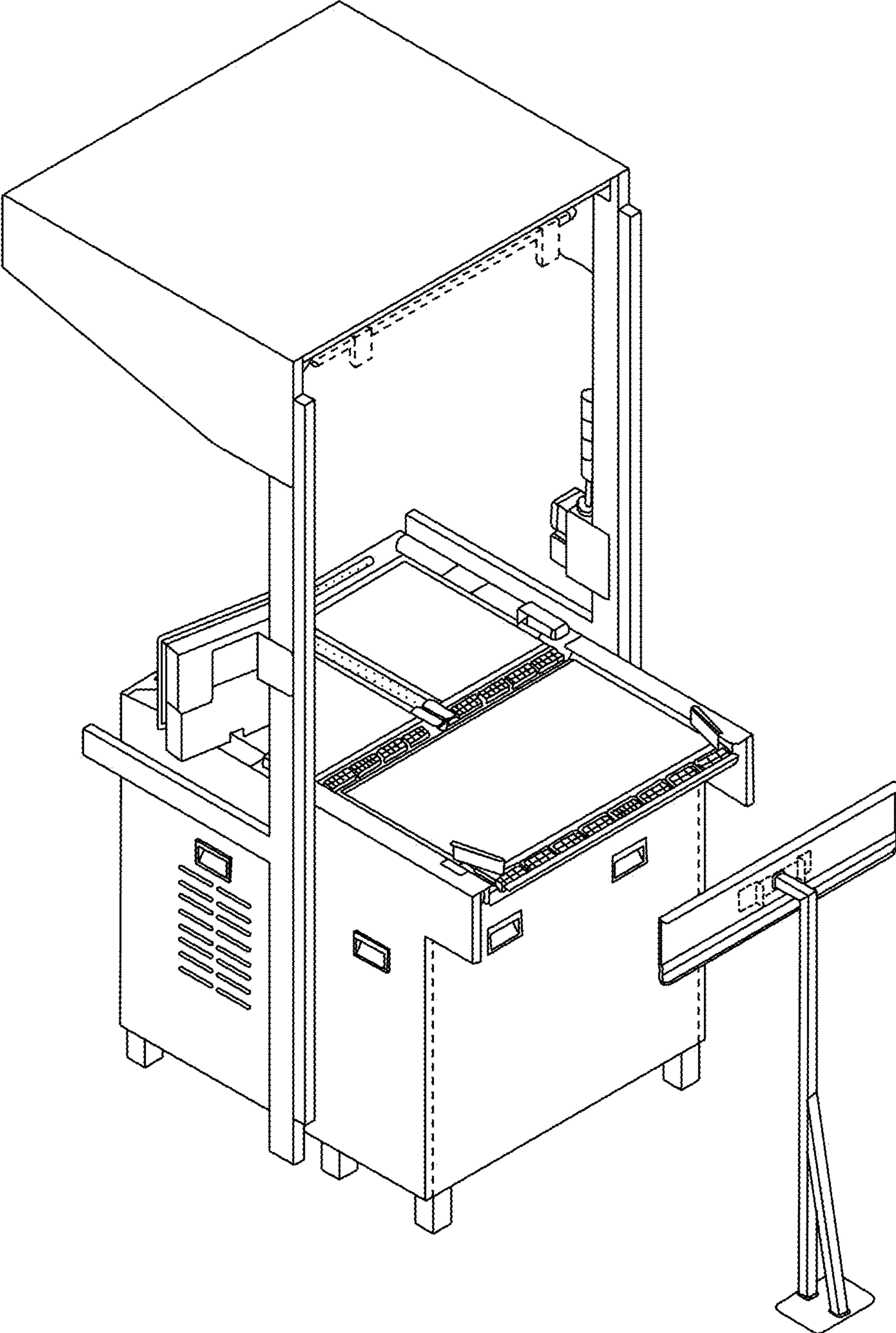

FIG. 1

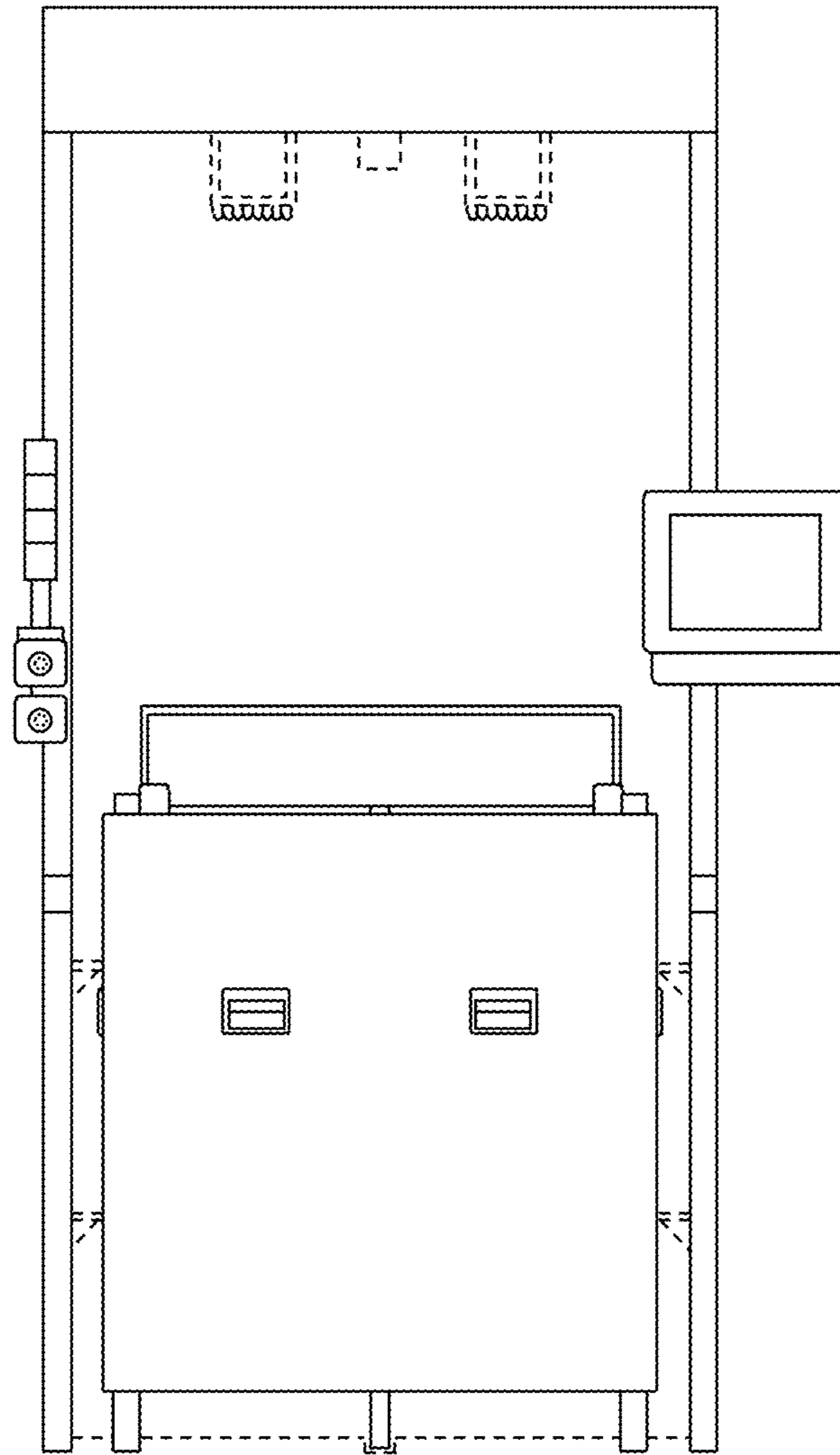

FIG. 2

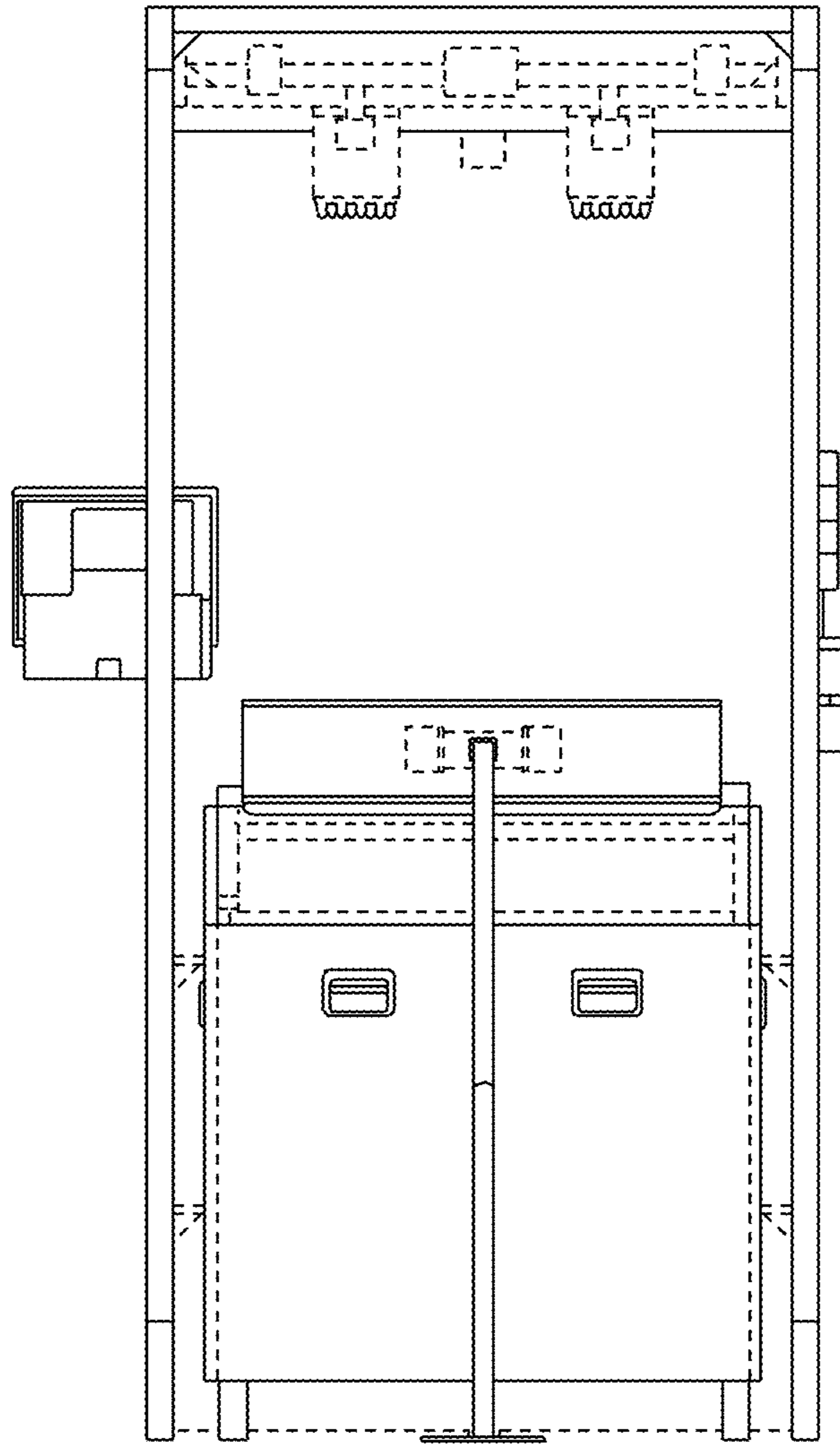

FIG. 3

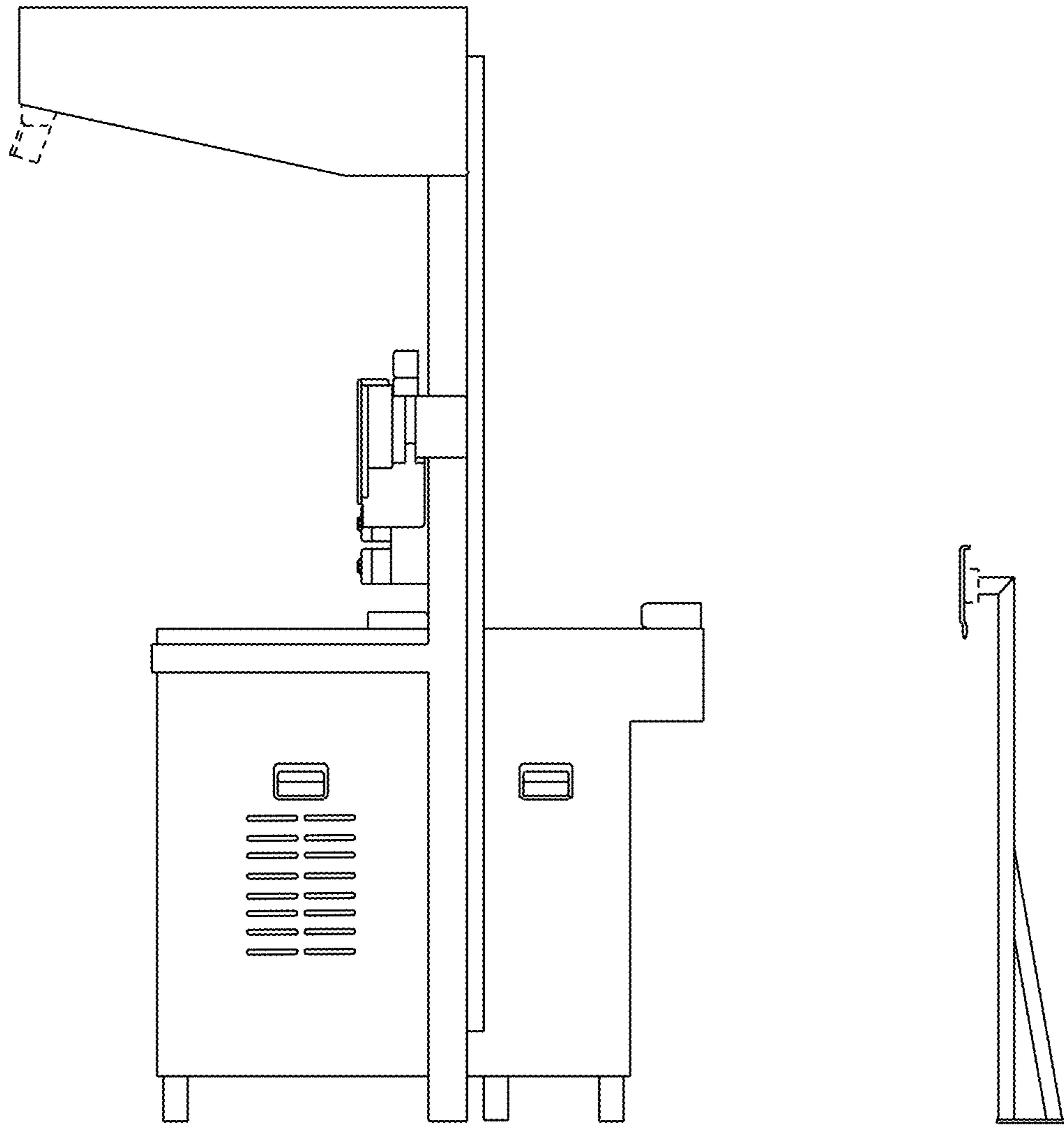

FIG. 4

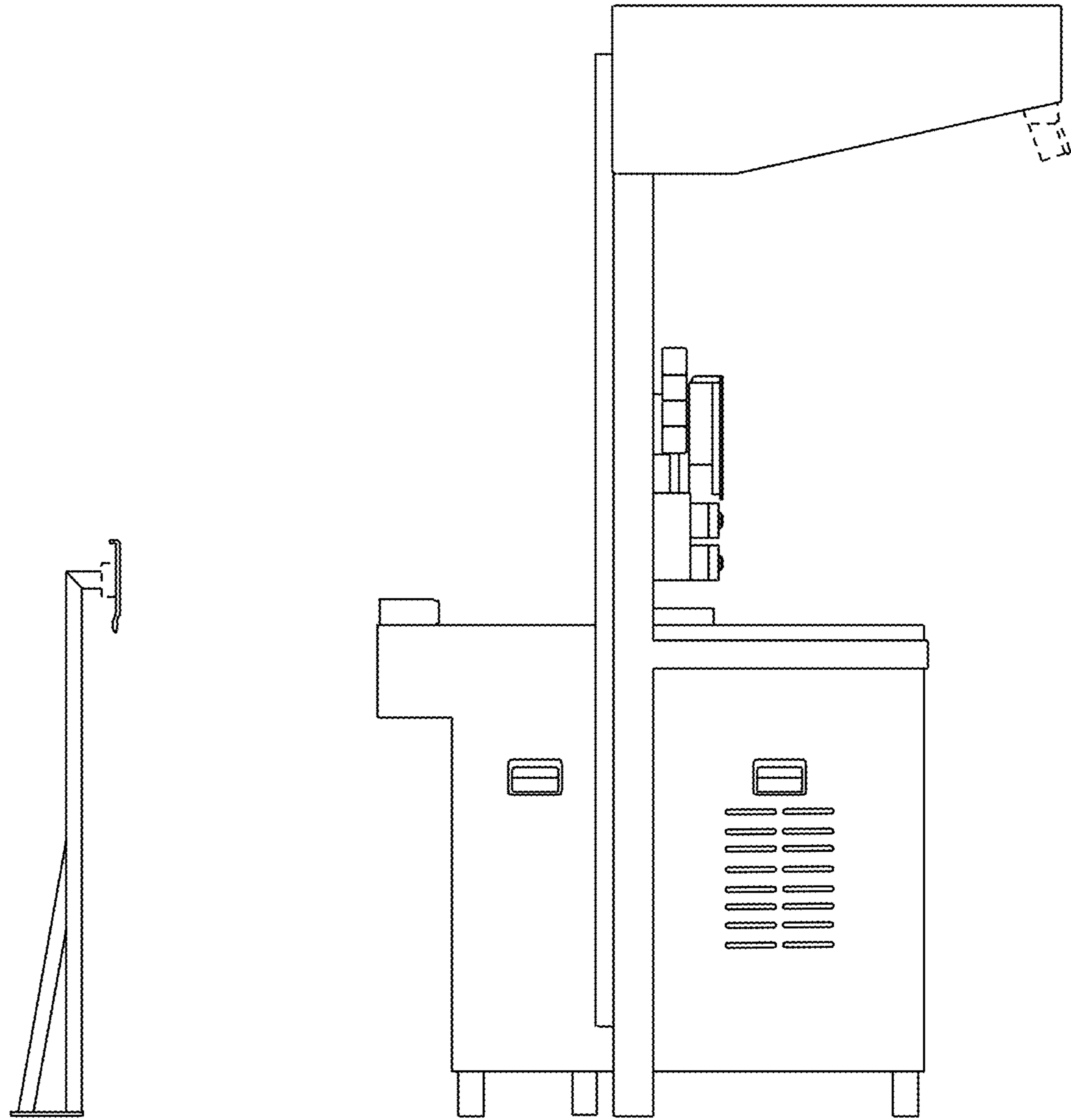

FIG. 5

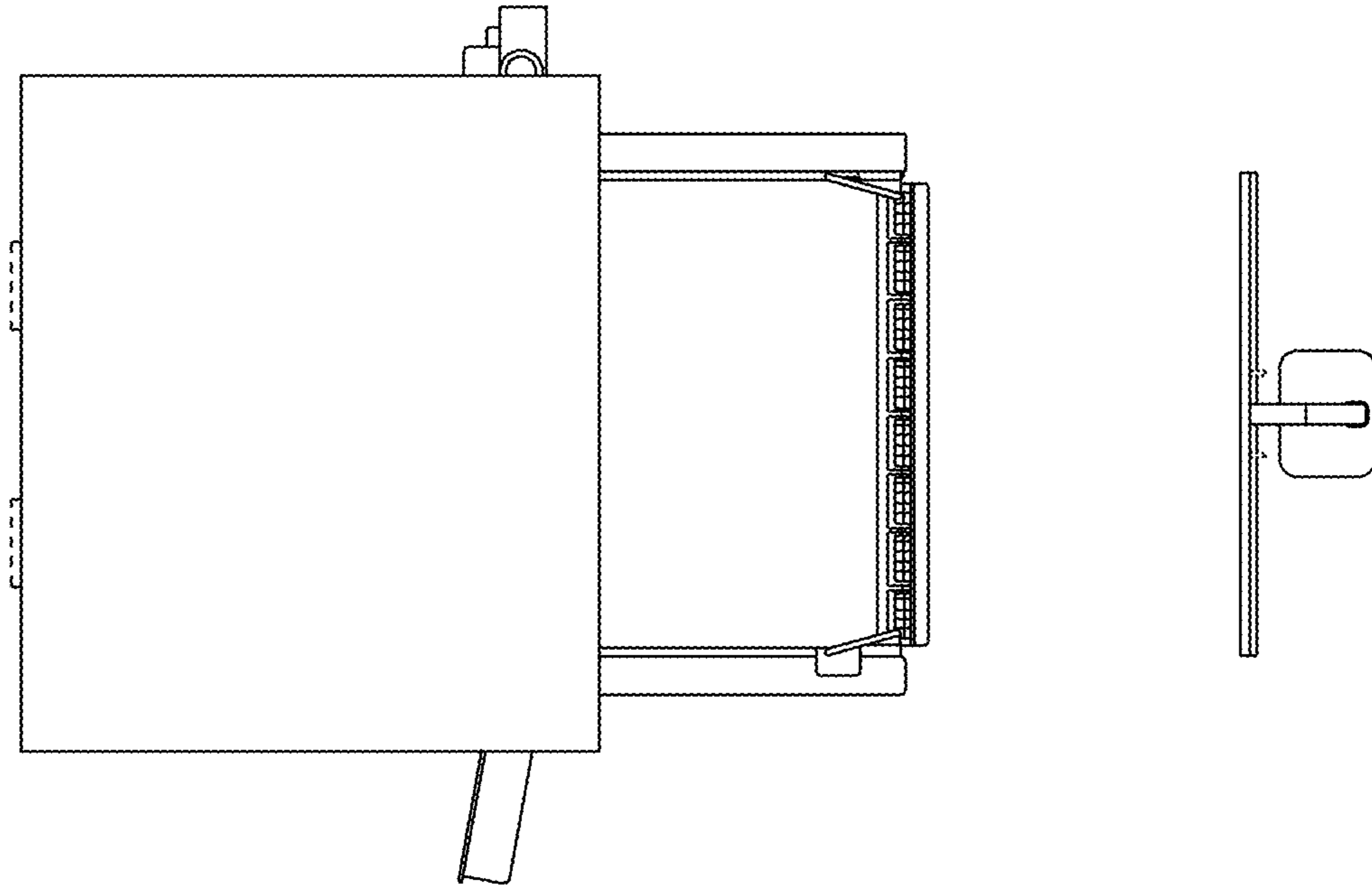

FIG. 6