



US00D949062S

(12) **United States Design Patent**
Chambers et al.

(10) **Patent No.:** **US D949,062 S**
(45) **Date of Patent:** **** Apr. 19, 2022**

(54) **MOTORBIKE SEAT WITH BATTERY BOX**

D906,954 S * 1/2021 Ouyang D13/103
D910,496 S * 2/2021 Zhu D12/111
D918,131 S * 5/2021 Suzuki D13/103

(71) Applicant: **Super73, Inc.**, Irvine, CA (US)

(72) Inventors: **Ian Chambers**, Irvine, CA (US);
Legrand Crewse, Irvine, CA (US)

(73) Assignee: **Super 73, Inc.**, Irvine, CA (US)

(**) Term: **15 Years**

(21) Appl. No.: **29/722,010**

(22) Filed: **Jan. 24, 2020**

(51) **LOC (13) Cl.** **12-11**

(52) **U.S. Cl.**
USPC **D12/114; D13/103**

(58) **Field of Classification Search**
USPC D12/110, 111, 114, 117; D21/432, 538;
D13/102-104, 110, 118-121, 184, 199
CPC B62K 11/00; B62K 11/02; B62K 11/04;
B62K 11/10; B62K 17/00; B62K 19/00;
B62K 2202/00; H01M 2/30; H01M 2/105
See application file for complete search history.

(56) **References Cited**

U.S. PATENT DOCUMENTS

D424,513 S * 5/2000 Birkestrand D13/103
D504,846 S * 5/2005 Sramek D12/111
D553,563 S * 10/2007 Pizzi D13/103
D620,400 S * 7/2010 Haller D12/111
D635,507 S * 4/2011 Ueda D13/103
D640,879 S * 7/2011 Curran D6/354
D702,630 S * 4/2014 Tinius D13/103
D764,411 S * 8/2016 Sondors D13/119
D816,022 S * 4/2018 Hino D13/103
D896,130 S * 9/2020 Quan D12/110

OTHER PUBLICATIONS

“Super73-Z1” Super73., posted date Feb. 3, 2019 [online], [retrieved on Jun. 16, 2021]. Retrieved from the Internet <<https://super73.com/collections/all-bikes/products/super73-z1-1>> (Year: 2019).*

(Continued)

Primary Examiner — Darlington Ly

Assistant Examiner — Nasim Abdulaziz Ali

(74) *Attorney, Agent, or Firm* — Stradling Yocca Carlson & Rauth

(57) **CLAIM**

The ornamental design for a motorbike seat with battery box, as shown and described.

DESCRIPTION

FIG. 1 is a top, front, and left side perspective view of a motorbike seat with battery box embodying our new design as installed on an exemplary motorbike;
FIG. 2 is a top, rear, and right side perspective view thereof;
FIG. 3 is a top, front, and left side perspective view thereof;
FIG. 4 is a top, rear, and right side perspective view thereof;
FIG. 5 is a left side elevation view thereof;
FIG. 6 is a right side elevation view thereof;
FIG. 7 is a front elevation view thereof;
FIG. 8 is a rear elevation view thereof;
FIG. 9 is a top plan view thereof; and,
FIG. 10 is a bottom plan view thereof.

The broken line showing of portions of the motorbike are provided for the purpose of illustrating environmental structure and form no part of the claimed design.

1 Claim, 6 Drawing Sheets

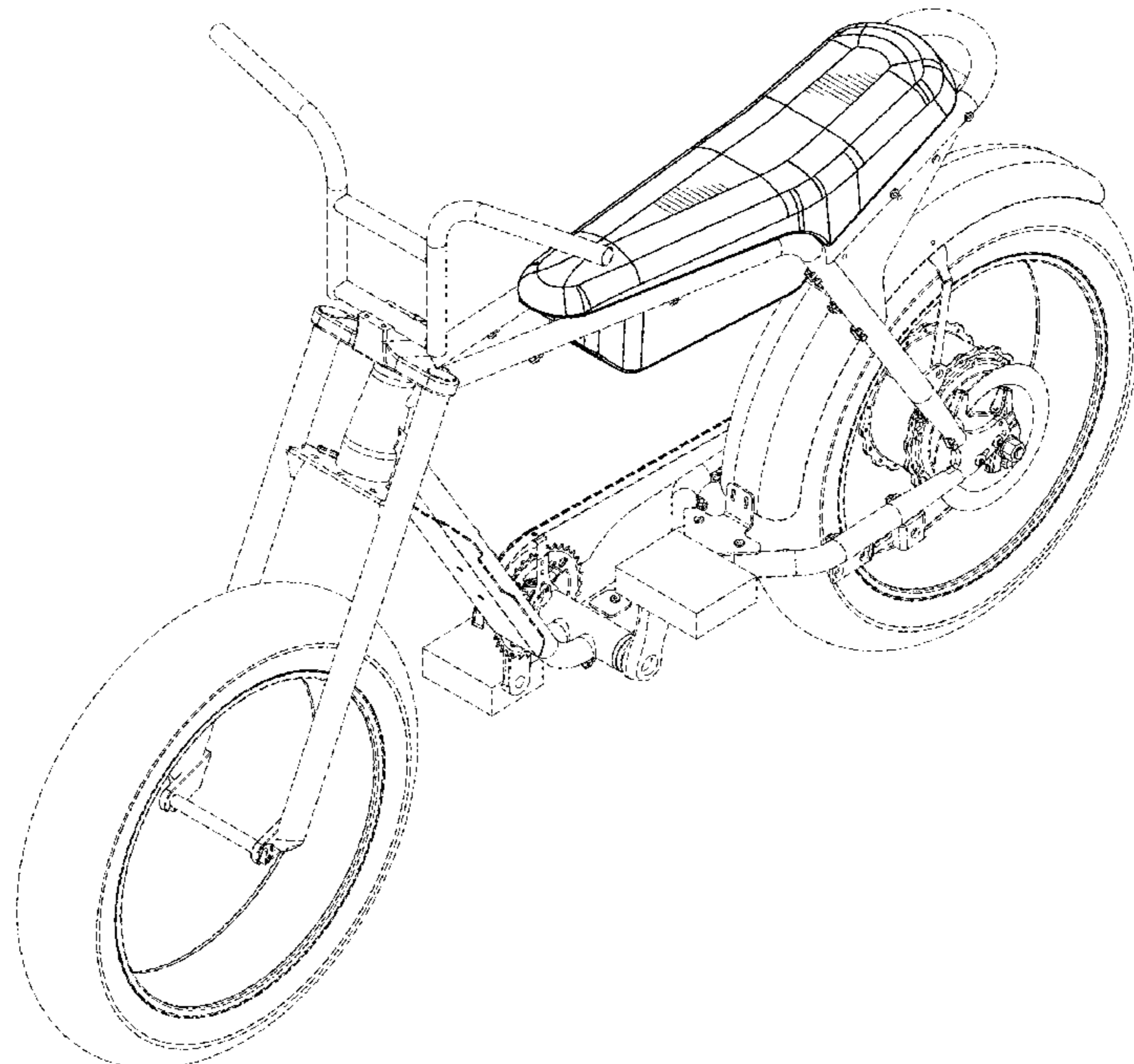

(56)

References Cited

OTHER PUBLICATIONS

“Super73-Z1 Jett Black Electric Motorbike” SUPER73., posted date Oct. 21, 2019 [online], [retrieved on Jun. 16, 2021]. Retrieved from the Internet <<https://www.amazon.com/dp/B07ZDL64Z1>> (Year: 2019).*

“Super73 Z1 e-bike review” electrek.co., posted date Apr. 6, 2020 [online], [retrieved on Jun. 16, 2021]. Retrieved from the Internet <<https://electrek.co/2020/04/06/super73-z1-e-bike-review-cheapest-e-bike-moped-minibike/>> (Year: 2020).*

<https://www.amazon.co.jp/Super-73-%E3%82%B9%E3%83%BC%E3%83%91%E3%83%BC73-Z1%E3%80%82/dp/B0>, May 2018.

<https://www.amazon.co.jp/Super-73-%E3%82%B9%E3%83%BC%E3%83%91%E3%83%BC73-Z1%E3%80%82/dp/B081JK987R>, May 2018.

<https://super73.com/products/super73-z1-1>, May 2018.

* cited by examiner

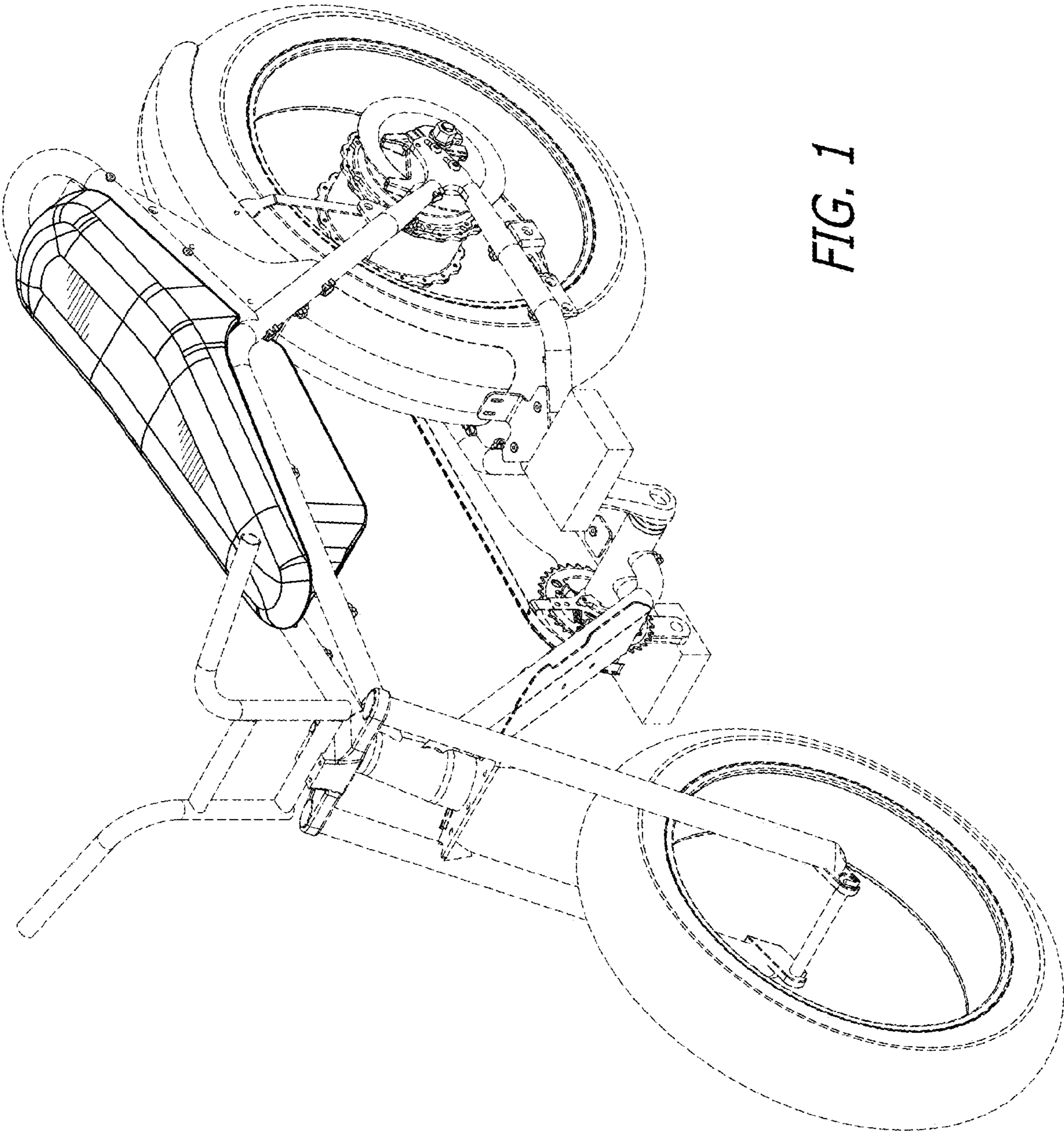

FIG. 1

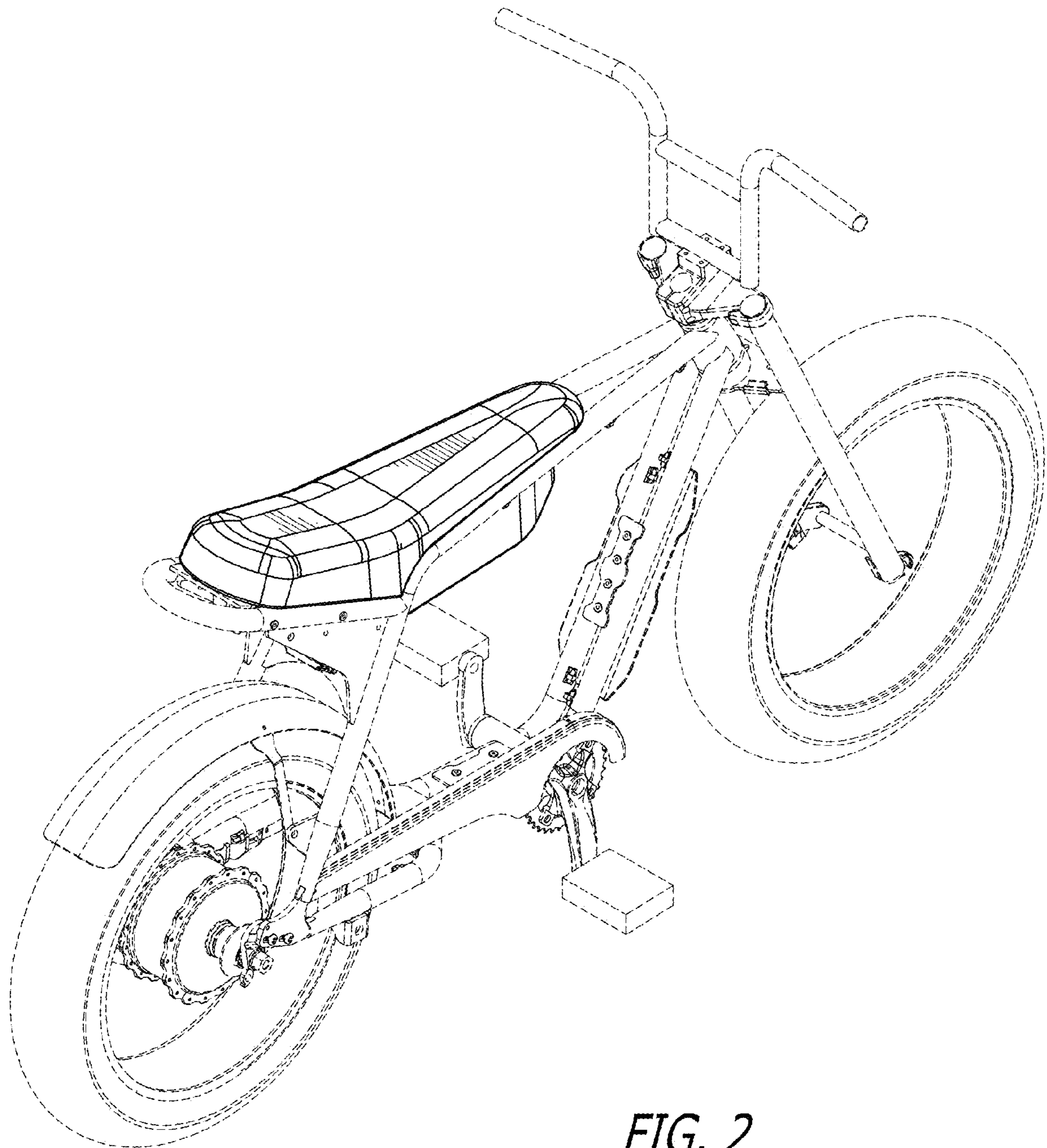

FIG. 2

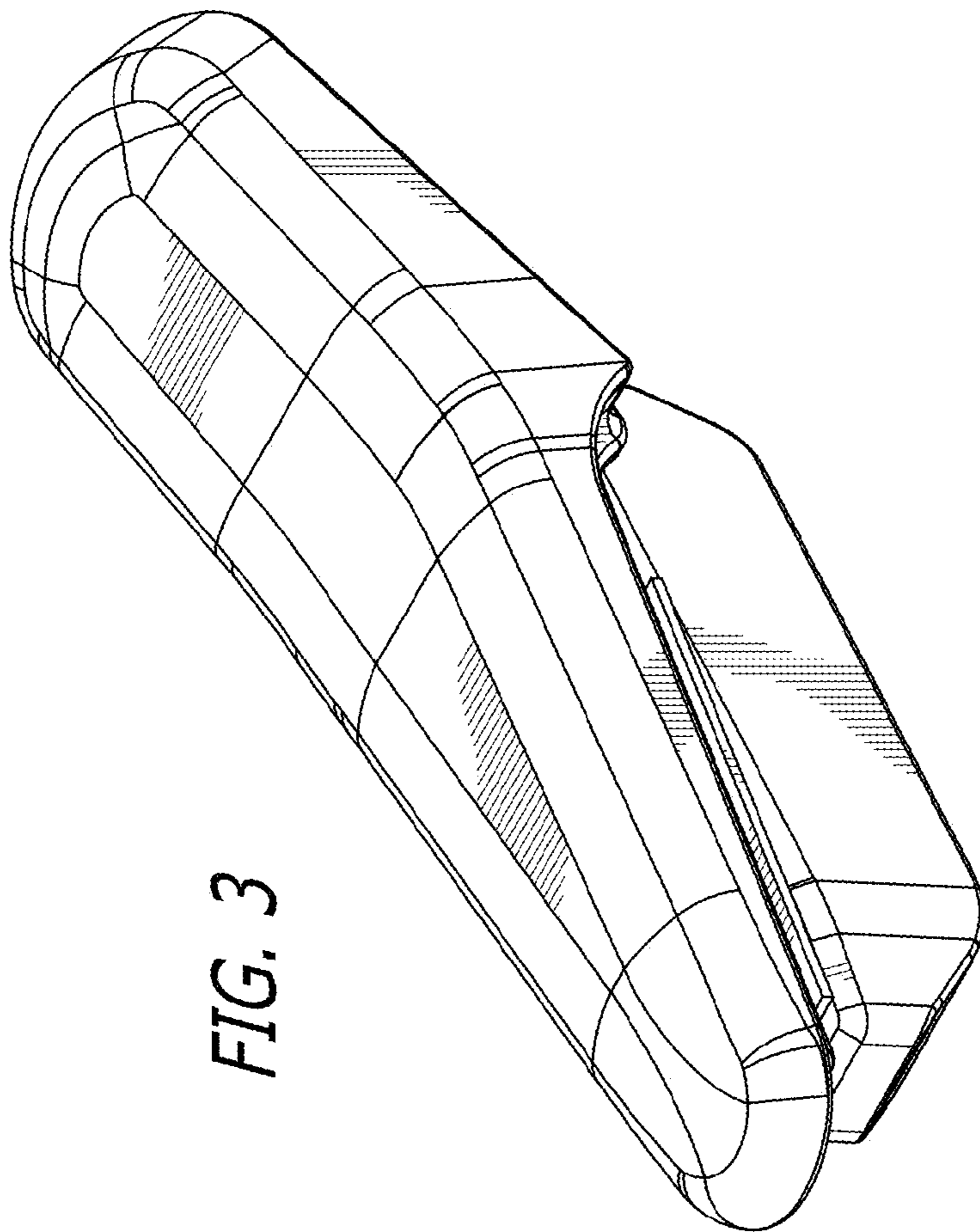

FIG. 3

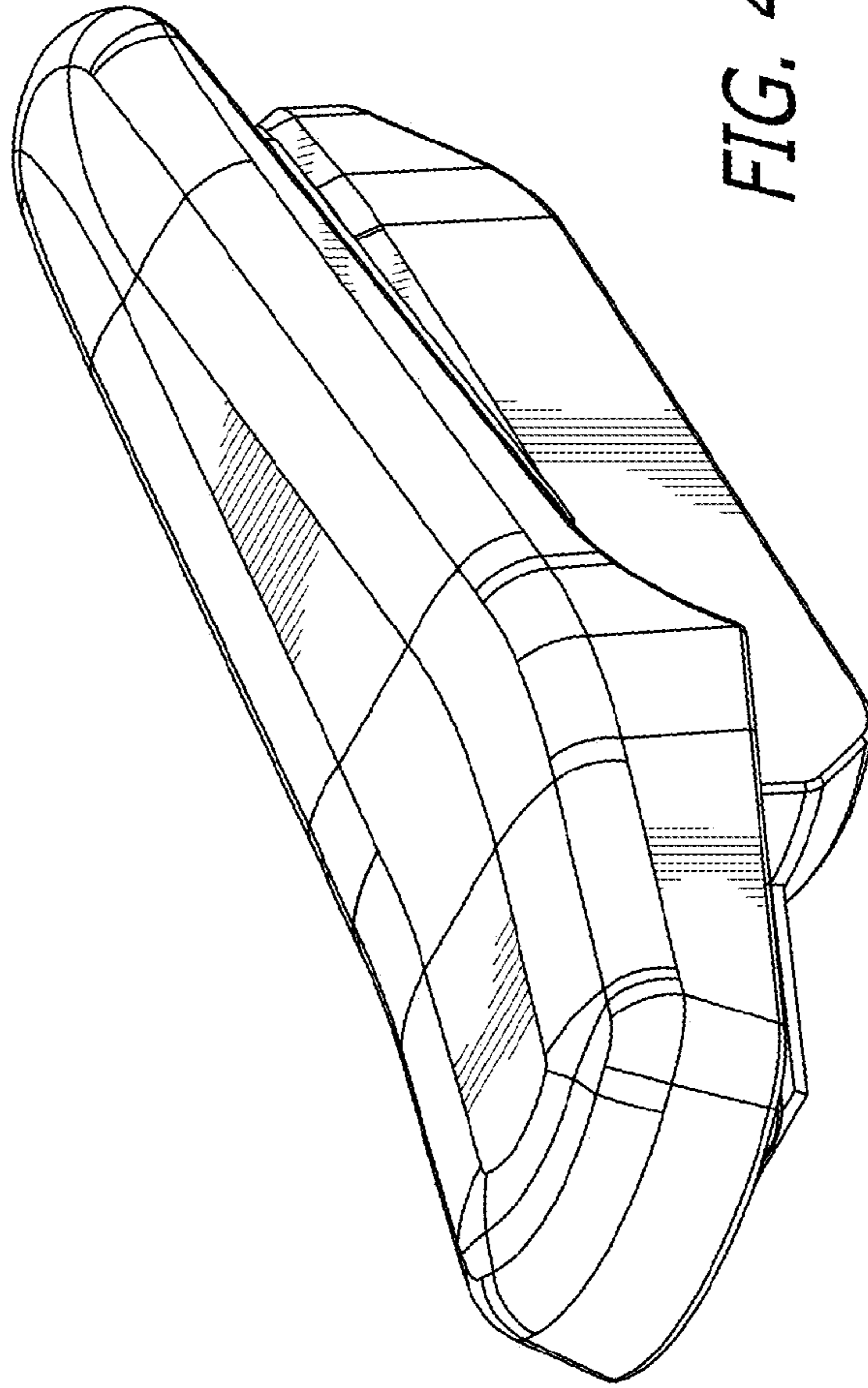
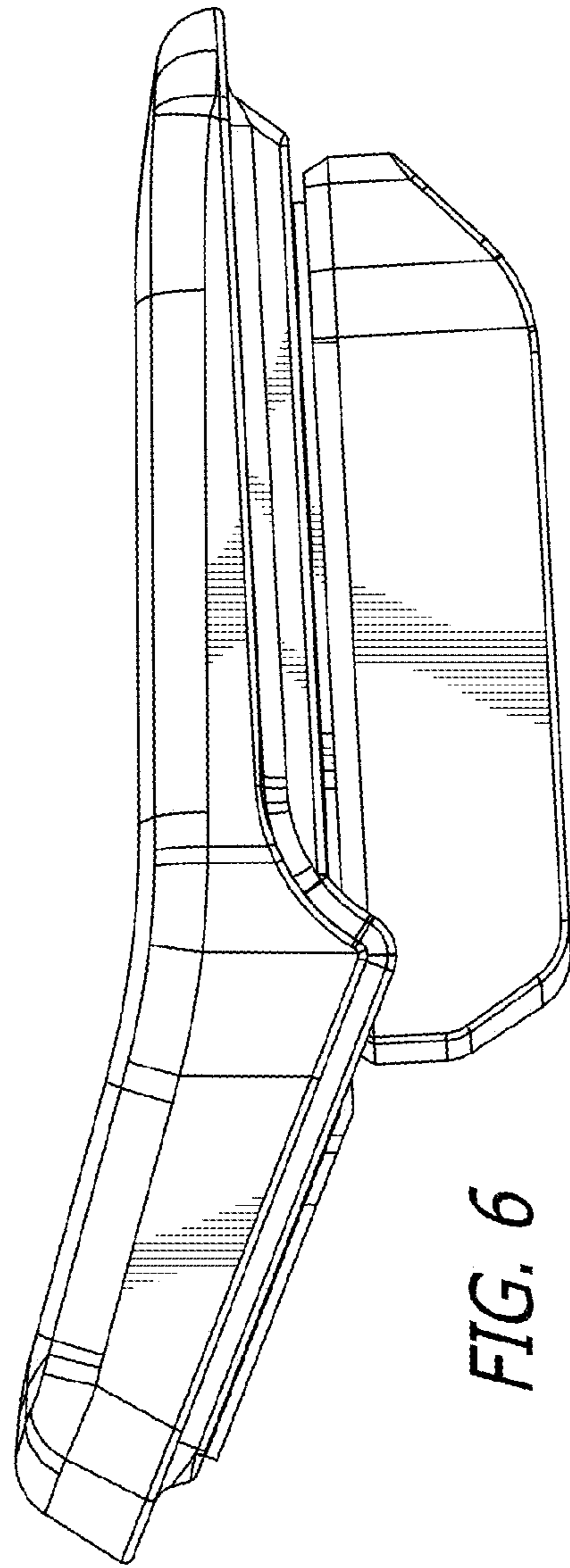
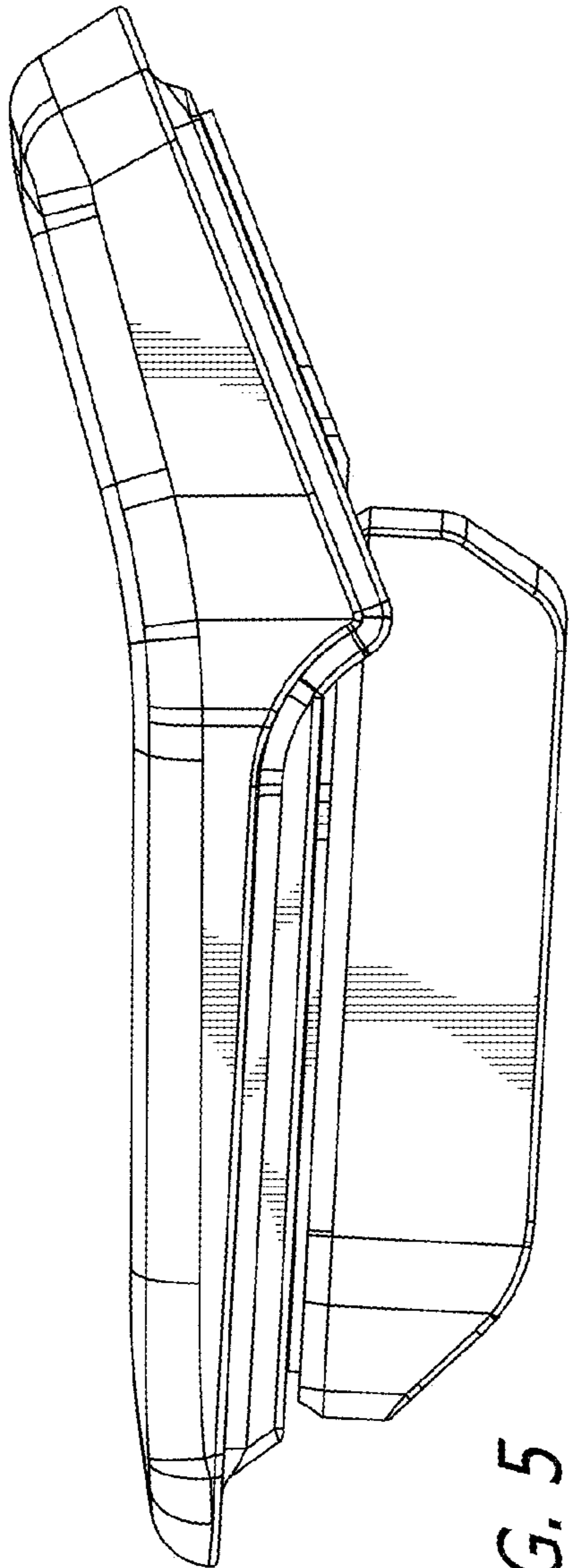

FIG. 4



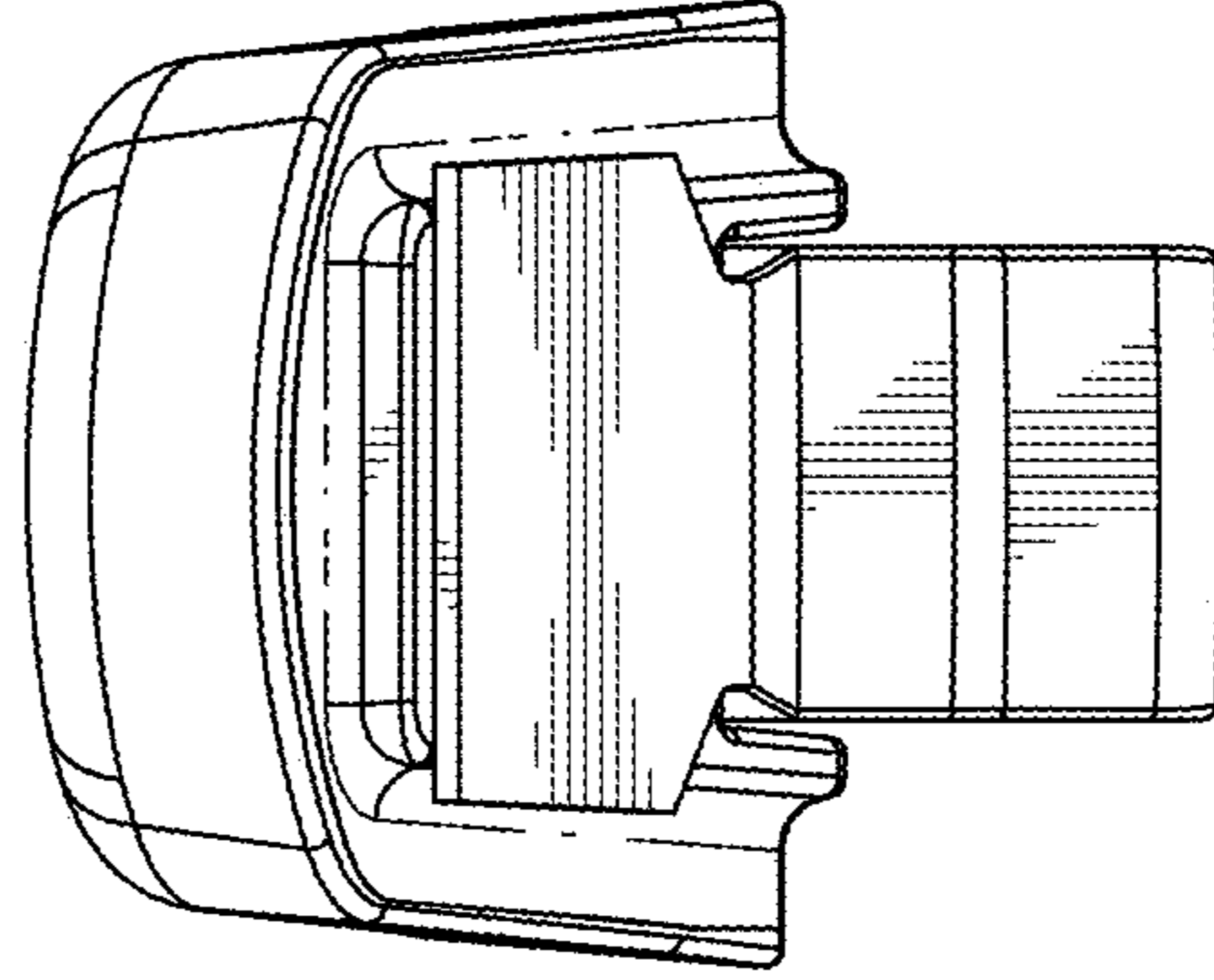

FIG. 8

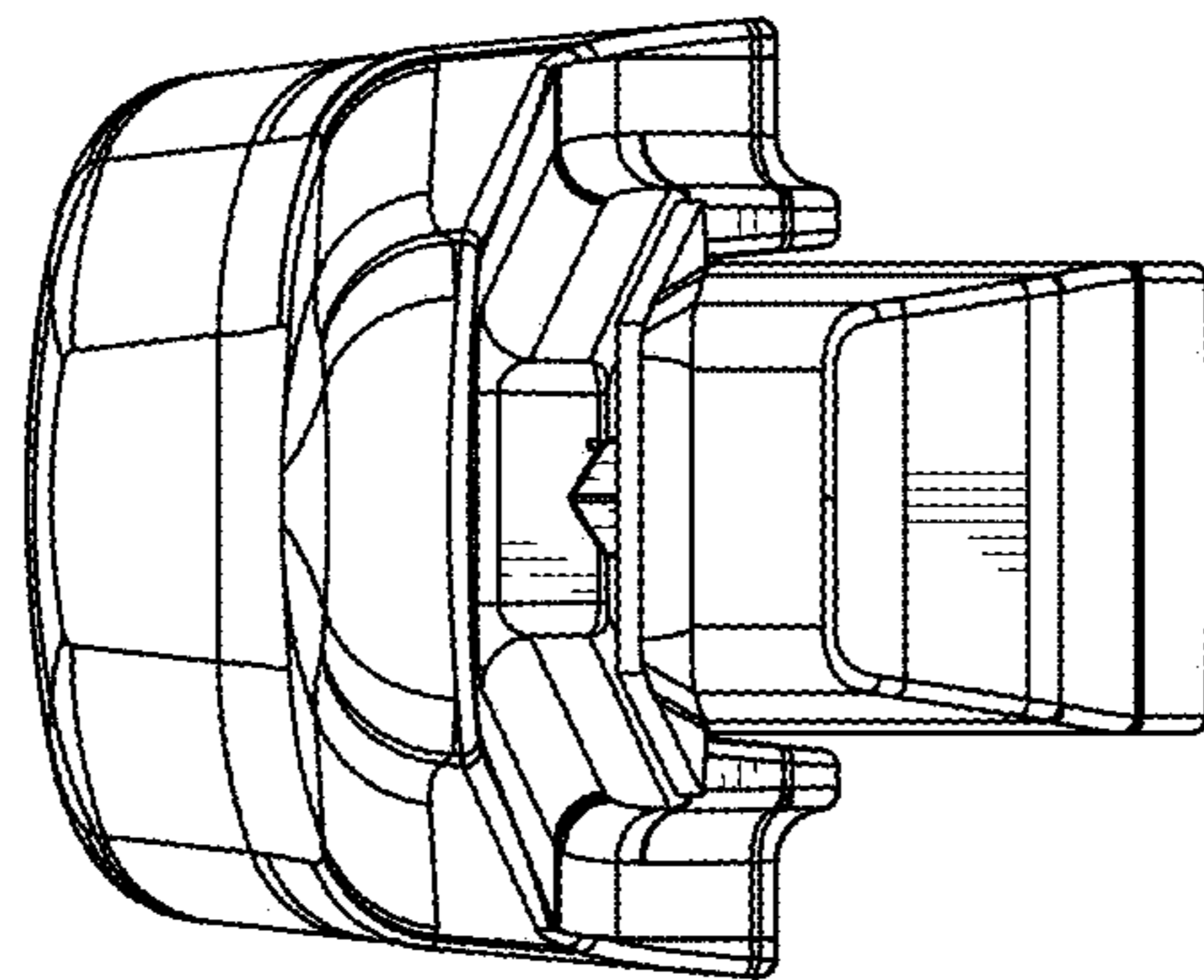

FIG. 7

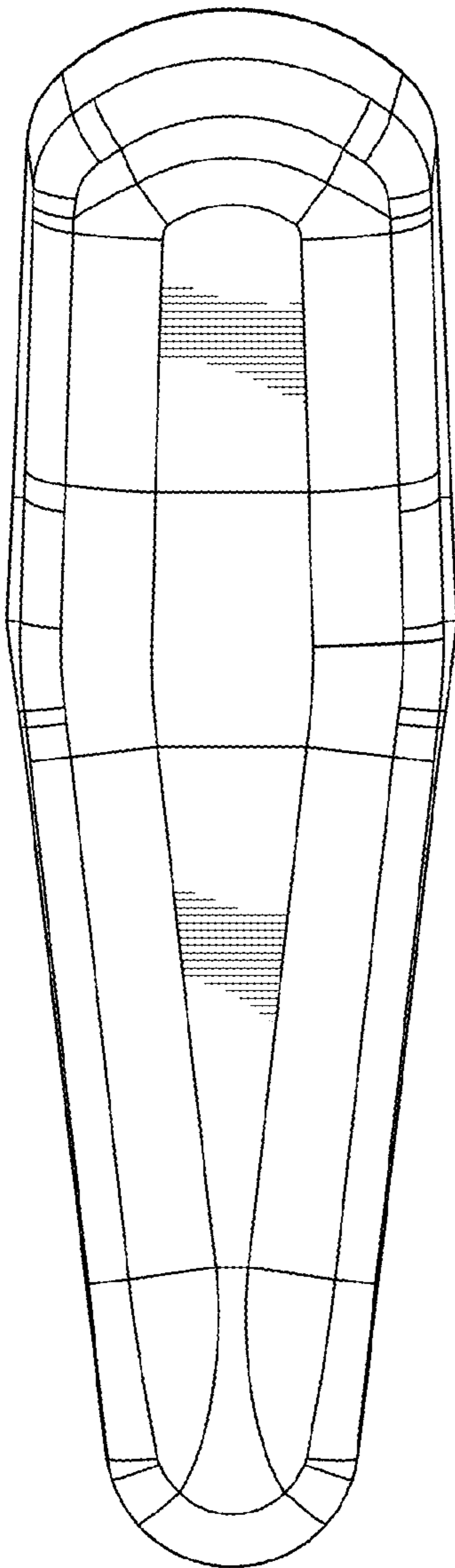

FIG. 9

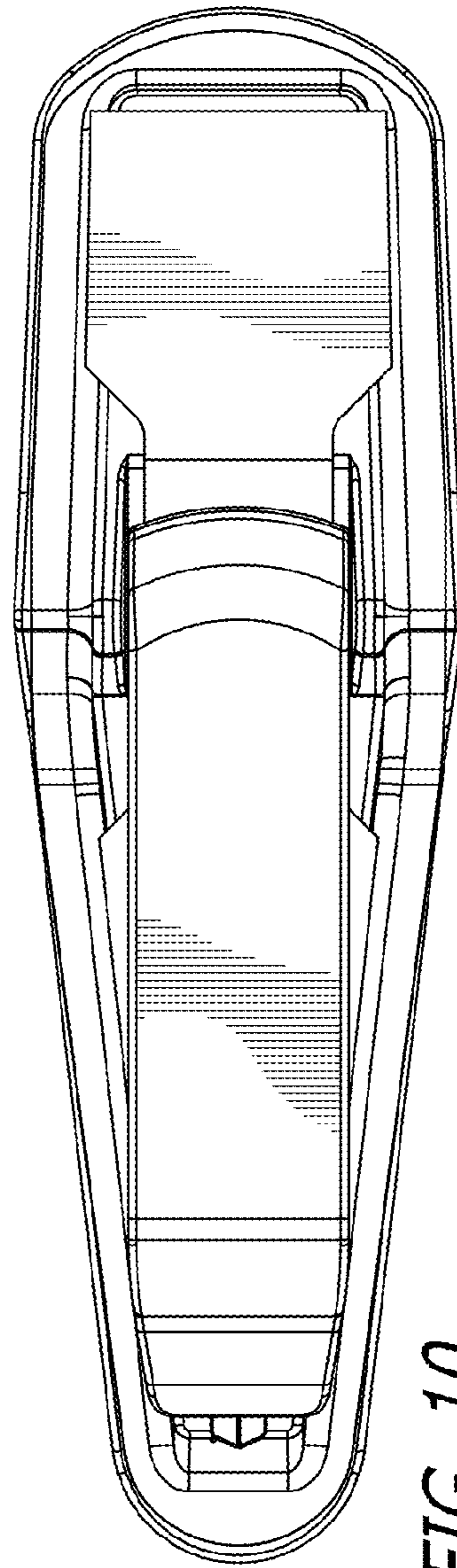

FIG. 10