

US00D949057S

(12) **United States Design Patent**
Watanabe

(10) **Patent No.:** **US D949,057 S**

(45) **Date of Patent:** **** Apr. 19, 2022**

(54) **BICYCLE FRAME**

D906,893 S * 1/2021 Lin D12/111
D908,046 S * 1/2021 Callahan D12/111
D909,921 S * 2/2021 Stafford D12/111
D923,519 S * 6/2021 Hafner D12/111

(71) Applicant: **VITAMIN-I FACTORY CO., LTD.**,
Tokyo (JP)

FOREIGN PATENT DOCUMENTS

(72) Inventor: **Mikio Watanabe**, Tokyo (JP)

IN 327227-001-0001 * 2/2020

(73) Assignee: **VITAMIN-I FACTORY CO., LTD.**,
Tokyo (JP)

OTHER PUBLICATIONS

(**) Term: **15 Years**

“SIR 9” Niner Bikes., posted date Jan. 29, 2019 [online], [retrieved on Aug. 11, 2021]. Retrieved from the Internet <URL:https://www.ninerbikes.com/products/air-9/> (Year: 2019).*

(21) Appl. No.: **29/735,450**

“S-Works Epic Hardtail” Specialized., posted date Jul. 23, 2020 [online], [retrieved on Aug. 11, 2021]. Retrieved from the Internet <URL:https://www.specialized.com/us/en/s-works-epic-hardtail/p/154340?color=237763-154340> (Year: 2020).*

(22) Filed: **May 21, 2020**

(Continued)

(30) **Foreign Application Priority Data**

Nov. 29, 2019 (JP) 2019-026618

(51) **LOC (13) Cl.** **12-11**

Primary Examiner — Darlington Ly

(52) **U.S. Cl.**
USPC **D12/111**

Assistant Examiner — Nasim Abdulaziz Ali

(58) **Field of Classification Search**
USPC D12/412, 414, 419, 423–428;
D21/423–428, 431–435
CPC B62K 3/00; B62K 3/02; B62K 3/06
See application file for complete search history.

(74) *Attorney, Agent, or Firm* — Im IP Law; Chai Im; C. Andrew Im

(57) **CLAIM**

(56) **References Cited**

The ornamental design for a bicycle frame, as shown and described.

U.S. PATENT DOCUMENTS

DESCRIPTION

D419,492 S * 1/2000 Egger D12/111
D517,452 S * 3/2006 Hickman D12/111
D632,615 S * 2/2011 Uimonen D12/111
D637,527 S * 5/2011 Choi D12/111
D667,347 S * 9/2012 Simko D12/111
D719,488 S * 12/2014 Stafford D12/111
D719,880 S * 12/2014 Juarez D12/111
D726,075 S * 4/2015 D’Aluisio D12/111
D734,218 S * 7/2015 D’Aluisio D12/111
D766,136 S * 9/2016 Jankura D12/111
D797,610 S * 9/2017 Jankura D12/111
D858,359 S * 9/2019 Lentz D12/111

FIG. 1 is a front elevation view of a bicycle frame showing my new design;
FIG. 2 is a rear elevation view thereof;
FIG. 3 is a top plan view thereof;
FIG. 4 is a bottom plan view thereof;
FIG. 5 is a left-side elevation view thereof;
FIG. 6 is a right-side elevation view thereof; and,
FIG. 7 is a left side elevation reference view thereof.

1 Claim, 7 Drawing Sheets

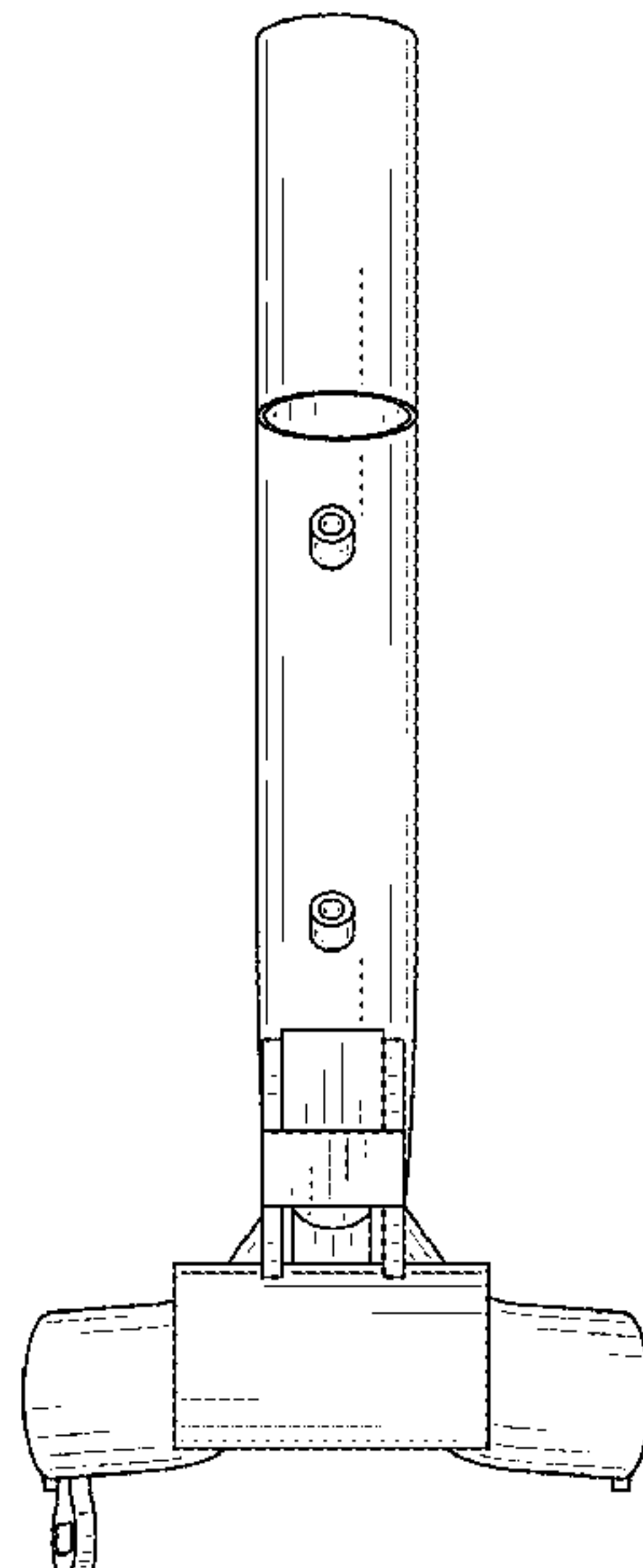

(56)

References Cited

OTHER PUBLICATIONS

“Aethos Pro—SRAM Force eTap AXS” Specialized., posted date Nov. 2, 2017 [online], [retrieved on Aug. 11, 2021]. Retrieved from the Internet <URL:<https://www.specialized.com/hn/en/aethos-pro---sram-force-etap-axs/p/199441?color=322981-199441>> (Year: 2017).*

* cited by examiner

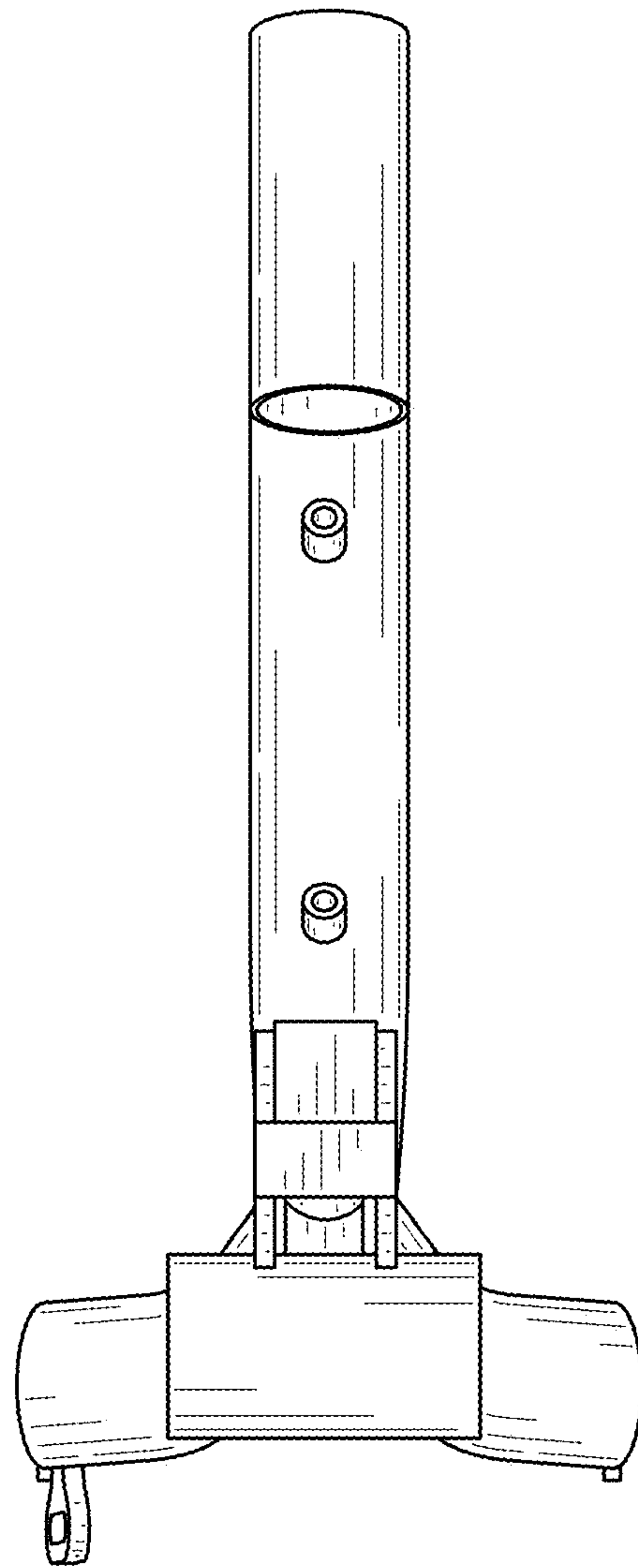

FIG. 1

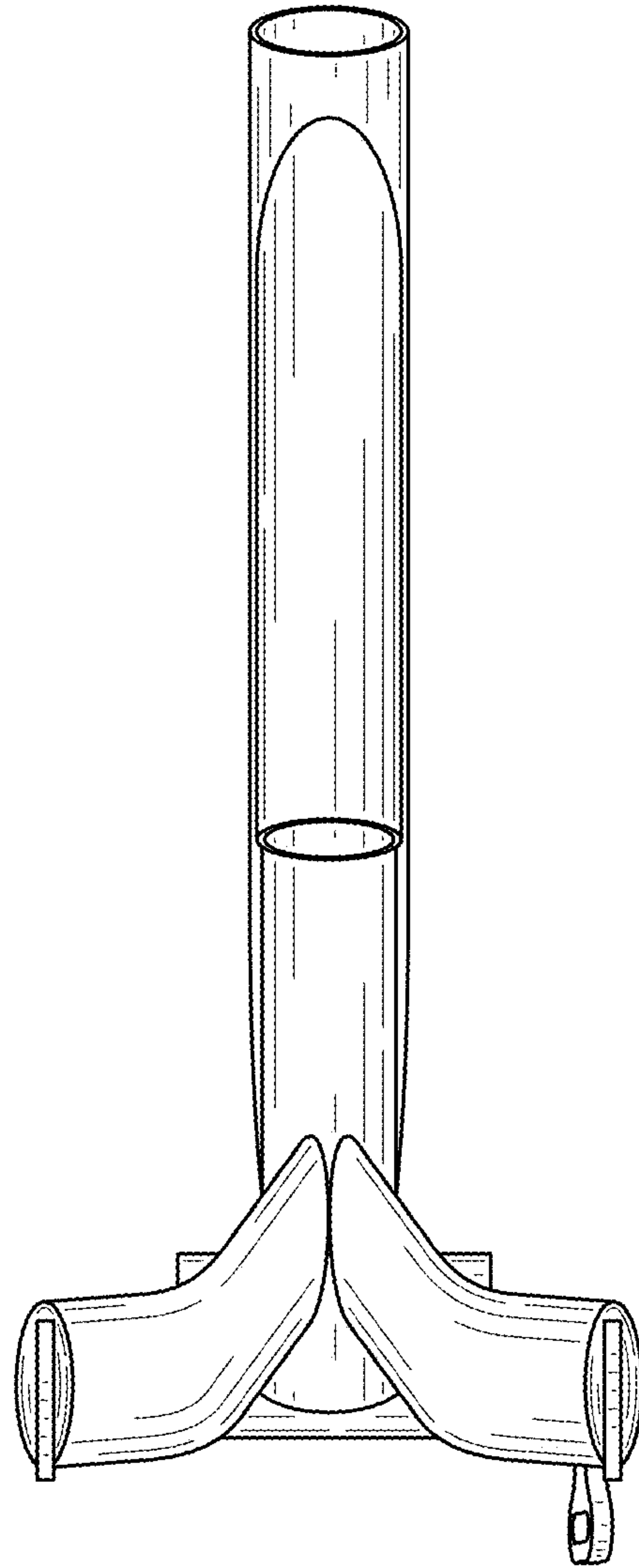

FIG. 2

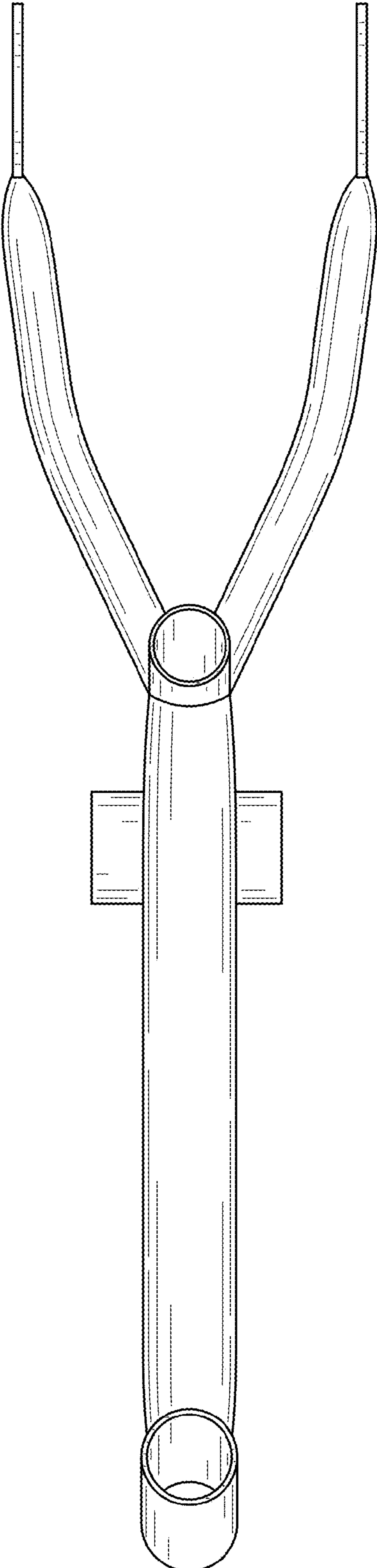

FIG. 3

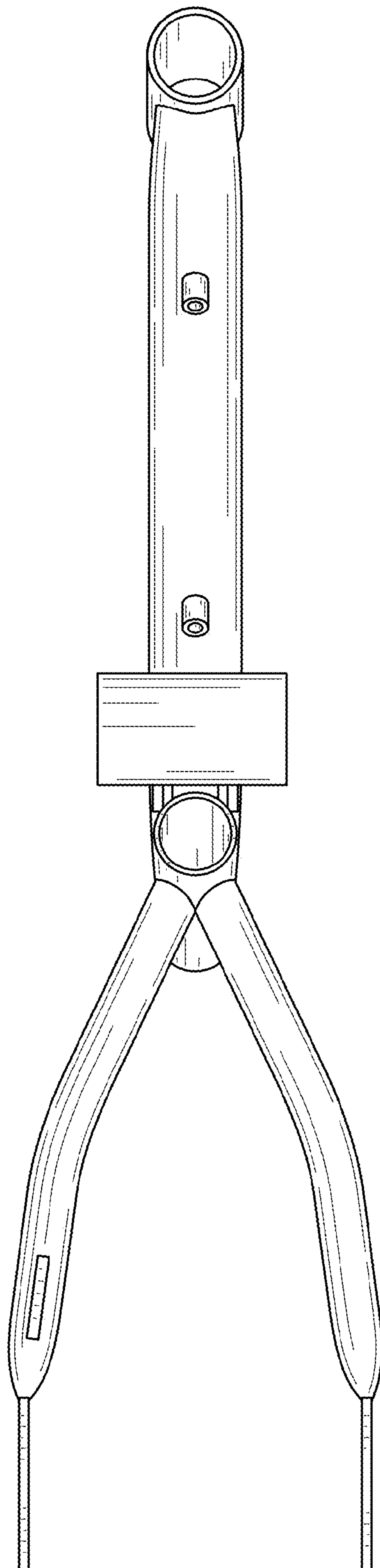

FIG. 4

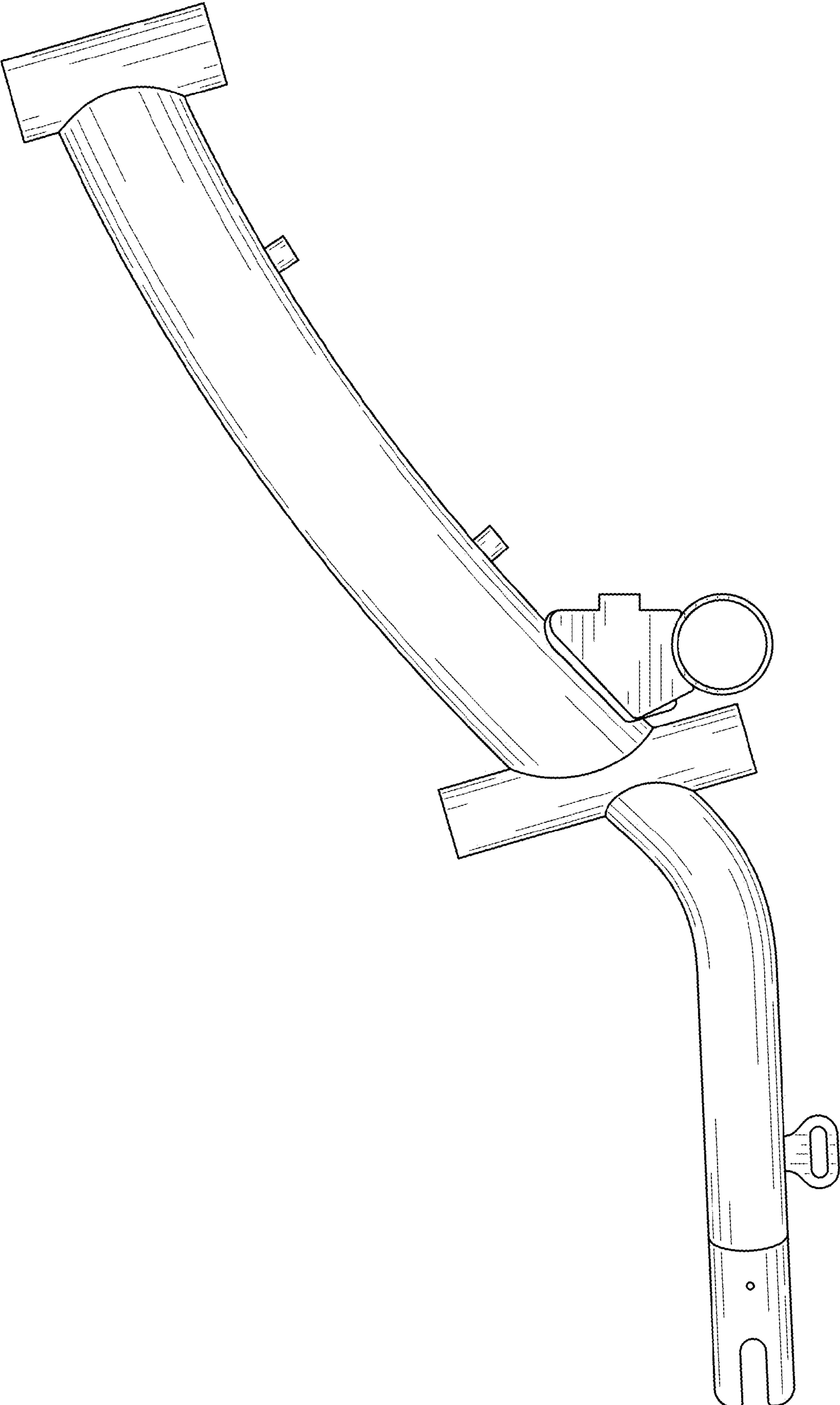

FIG. 5

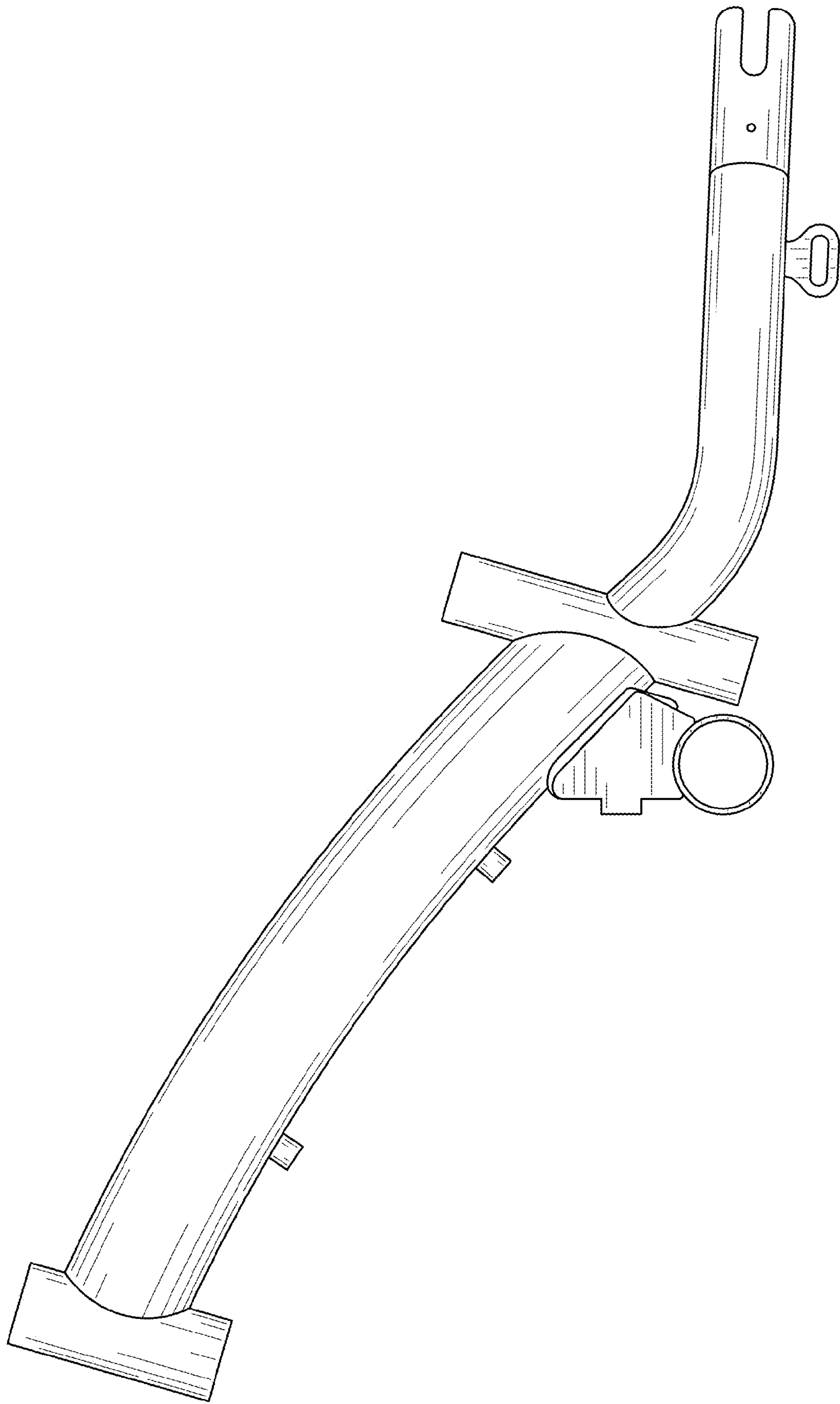

FIG. 6

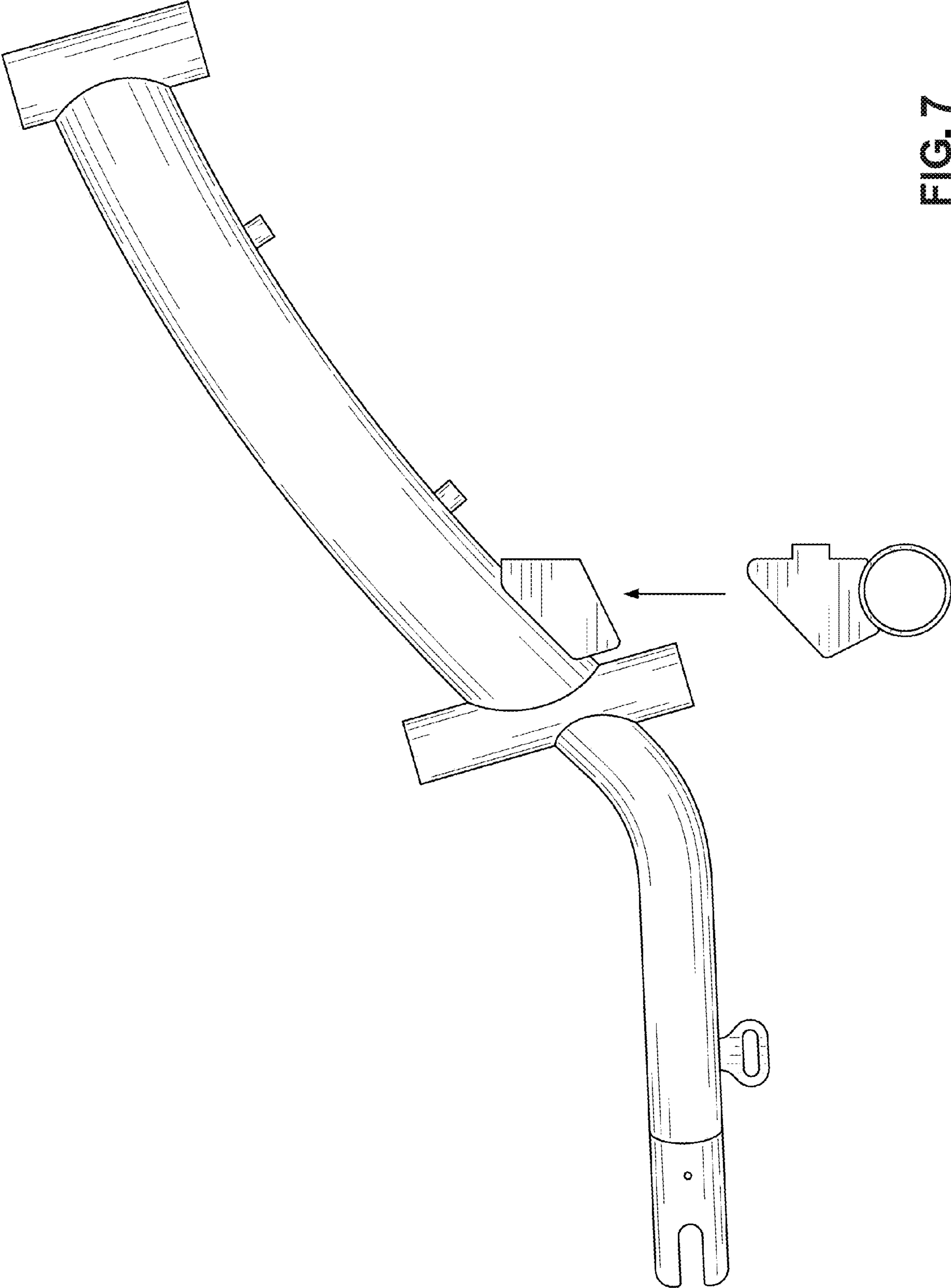

FIG. 7