



US00D948727S

(12) **United States Design Patent** (10) **Patent No.:** **US D948,727 S**
Sekine (45) **Date of Patent:** **** Apr. 12, 2022**

(54) **ULTRASONIC PROBE**

D910,857 S * 2/2021 Shibayama D24/187
D916,295 S * 4/2021 Shibayama D24/187
D917,705 S * 4/2021 Kurachi D24/187

(71) Applicant: **CANON MEDICAL SYSTEMS CORPORATION**, Otawara (JP)

FOREIGN PATENT DOCUMENTS

(72) Inventor: **Naofumi Sekine**, Kawasaki (JP)

JP D2016-12617 * 11/2016
JP D2018-1843 * 10/2018

(**) Term: **15 Years**

OTHER PUBLICATIONS

(21) Appl. No.: **29/748,752**

(22) Filed: **Sep. 1, 2020**

(30) **Foreign Application Priority Data**

May 11, 2020 (JP) 2020-009219

(51) **LOC (13) Cl.** **24-02**

(52) **U.S. Cl.**
USPC **D24/187**

(58) **Field of Classification Search**
USPC D24/133, 137, 138, 141, 158, 160, 164,
D24/165, 167, 170, 186, 187, 200;
D10/57, 60, 78, 80
CPC ... A61B 5/0095; A61B 8/4444; A61B 8/4455;
A61B 8/445; A61B 8/58; A61B 8/4254;
G01S 7/5208; G01N 29/265; A61L
31/129

See application file for complete search history.

Would you use a dirty ultrasound probe on yourself? online, published date 2018. Retrieved on Oct. 24, 2021 from URL: <https://healthmanagement.org/c/hospital/issuearticle/would-you-use-a-dirty-ultrasound-probe-on-yourself>.*

High frequency probes deliver improved visualisation of nerves and tendons at Addenbrooke's. Online, published date Sep. 17, 2021. Retrieved on Oct. 24, 2021 from URL: <https://www.radmagazine.com/high-frequency-probes-deliver-improved-visualisation-of-nerves-and-tendons-at-addenbrookes/>.*

* cited by examiner

Primary Examiner — Omeed Agilee
(74) *Attorney, Agent, or Firm* — Finnegan, Henderson, Farabow, Garrett & Dunner, L.L.P.

(57) **CLAIM**

The ornamental design for an ultrasonic probe, as shown and described.

DESCRIPTION

(56) **References Cited**

U.S. PATENT DOCUMENTS

D555,252 S * 11/2007 Kitayama D24/186
D595,846 S * 7/2009 Racz D24/129
D811,607 S * 2/2018 Kitayama D24/187
D811,608 S * 2/2018 Kitayama D24/187
D822,837 S * 7/2018 Naka D24/187
D842,482 S * 3/2019 Harada D24/187
D862,710 S * 10/2019 Moon D24/187
D883,494 S * 5/2020 Luo D24/187
D883,495 S * 5/2020 Cheng D24/187
D884,193 S * 5/2020 Robinson D24/187
D887,561 S * 6/2020 Cheng D24/187
D896,973 S * 9/2020 Wight D24/187

FIG. 1 is a perspective view of an ultrasonic probe showing my new design;

FIG. 2 is a perspective view thereof;

FIG. 3 is a front elevational view thereof;

FIG. 4 is a rear elevational view thereof;

FIG. 5 is a top plan view thereof;

FIG. 6 is a bottom plan view thereof;

FIG. 7 is a left side elevational view thereof; and,

FIG. 8 is a right-side elevational view thereof.

The broken lines in the drawings depict portions of the ultrasonic probe that form no part of the claimed design.

1 Claim, 8 Drawing Sheets

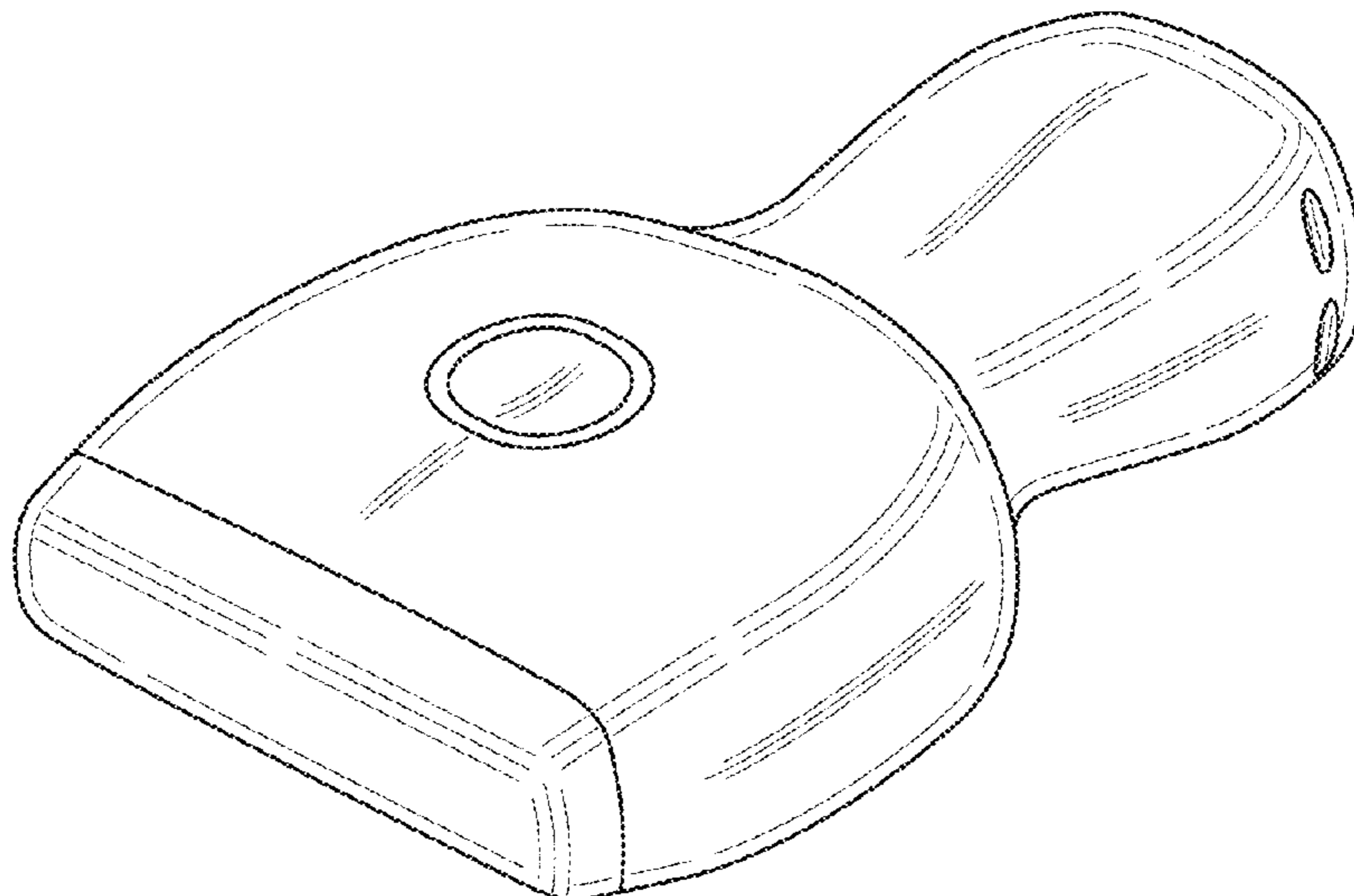

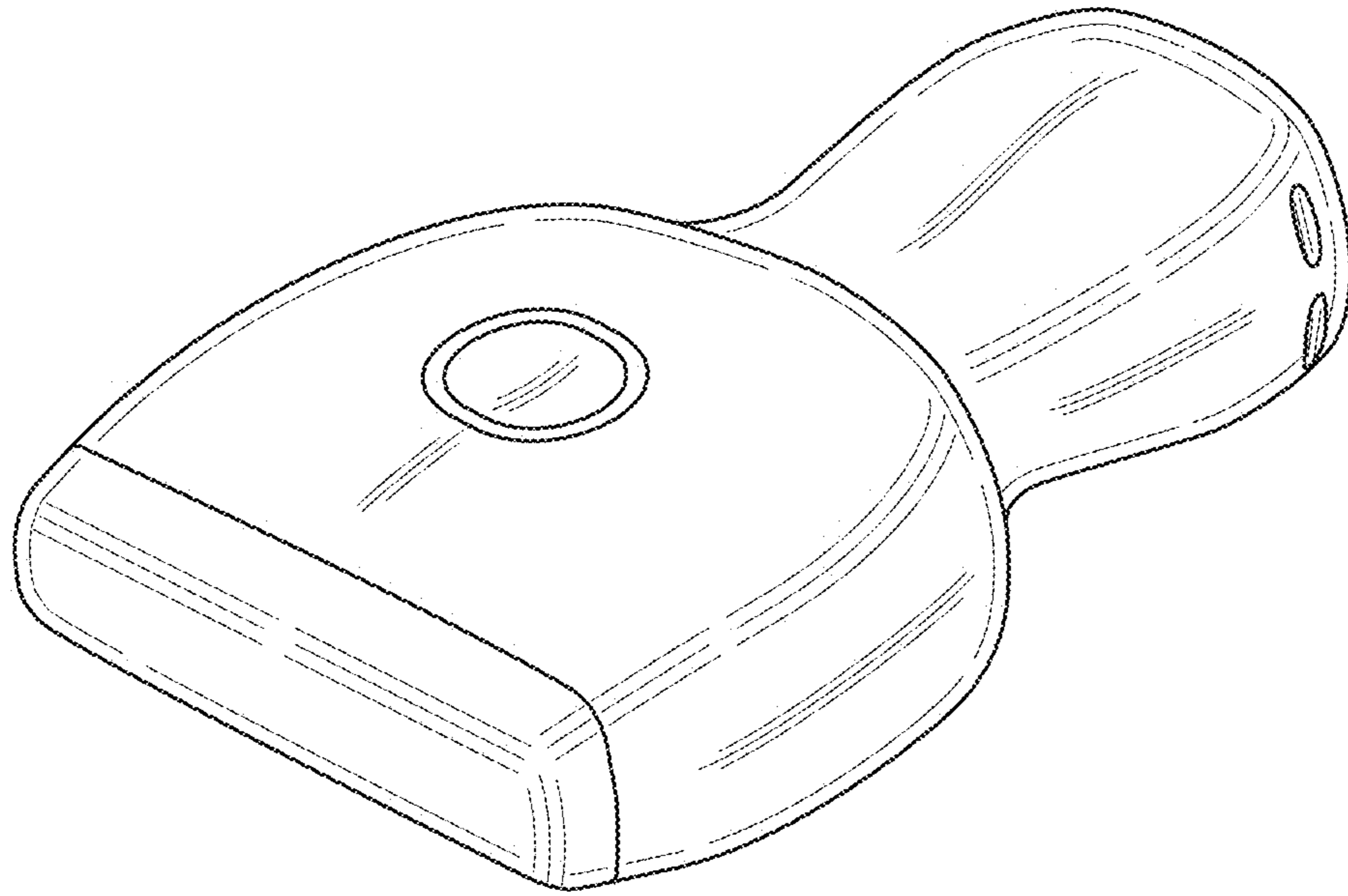

FIG. 1

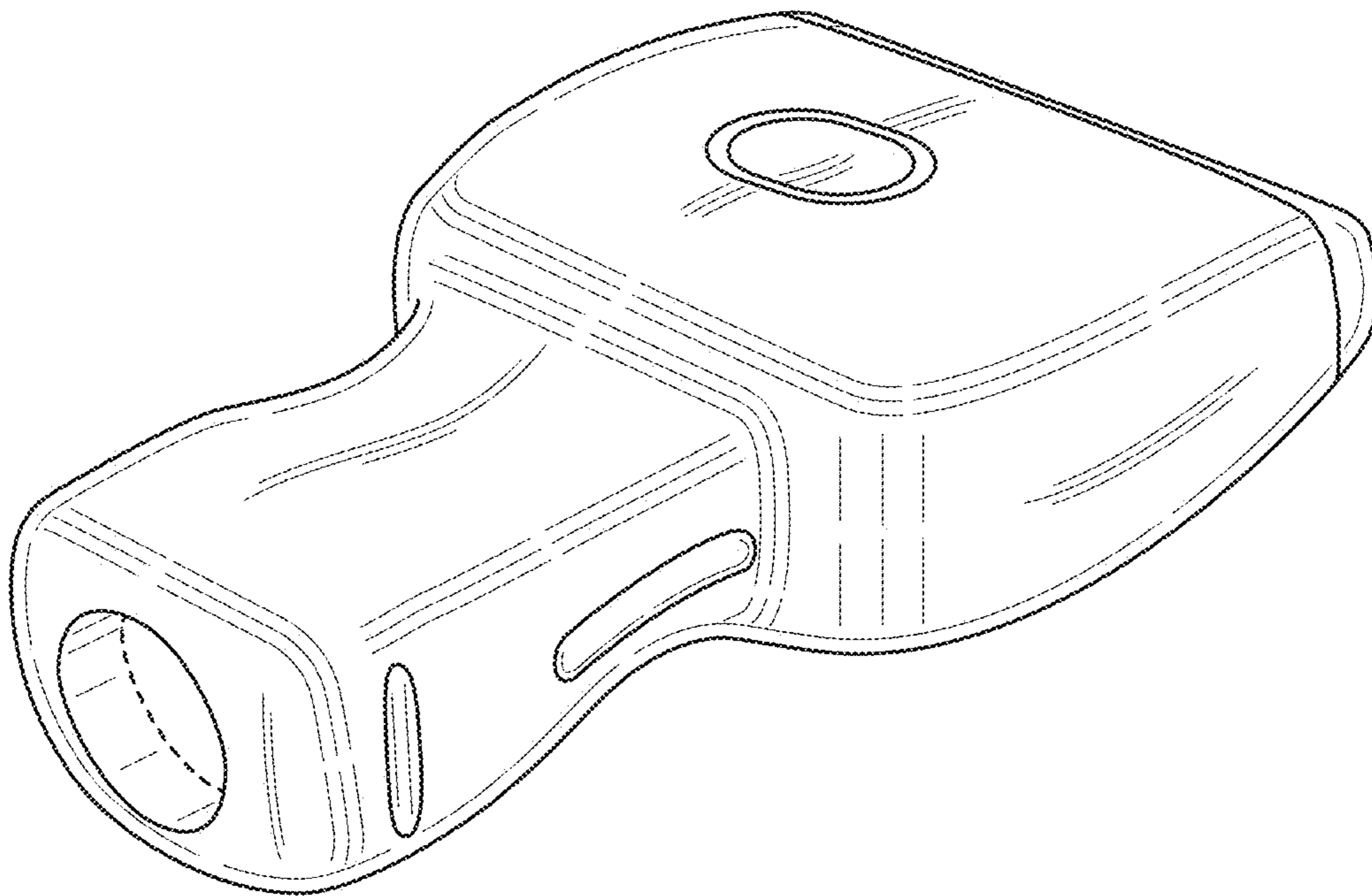

FIG. 2

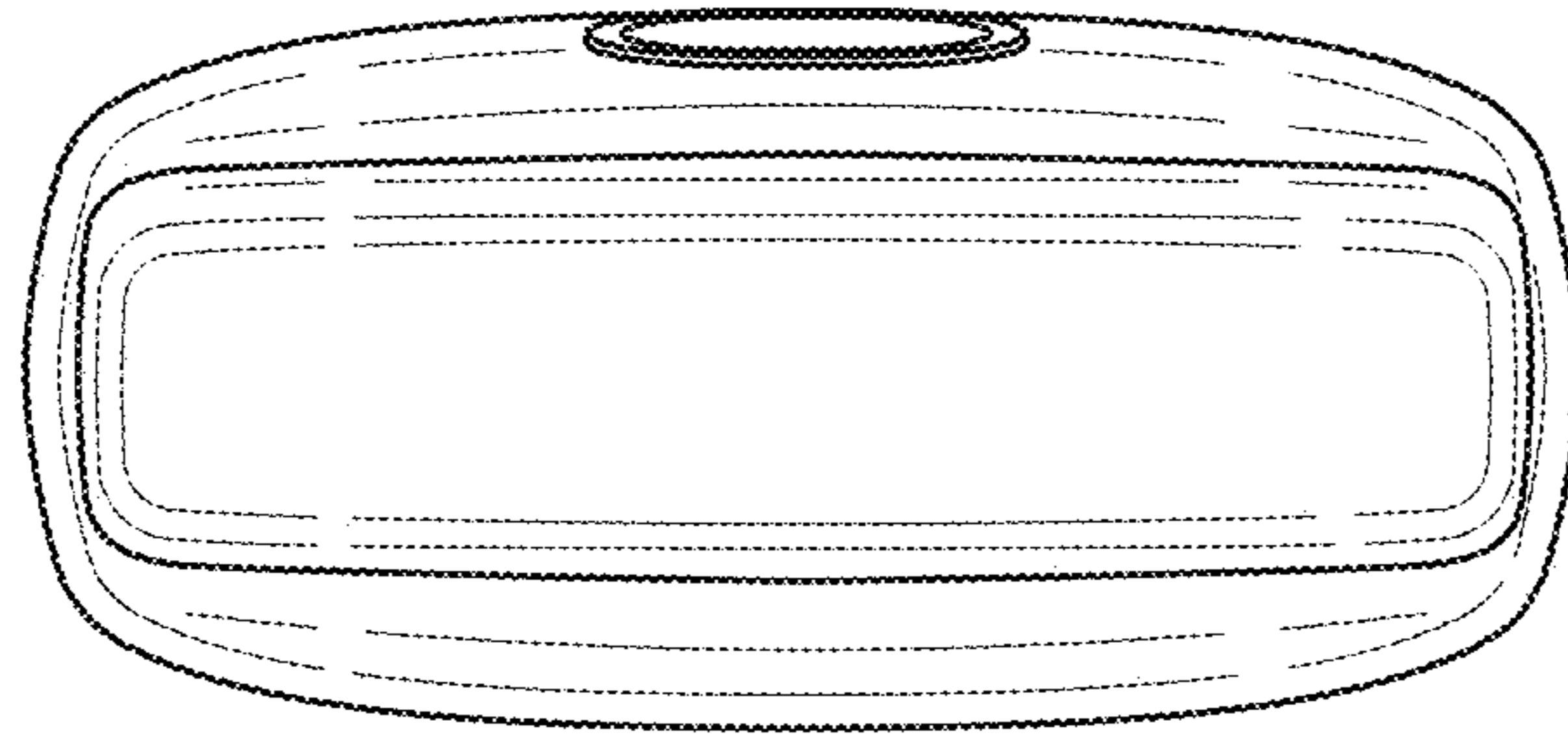

FIG. 3

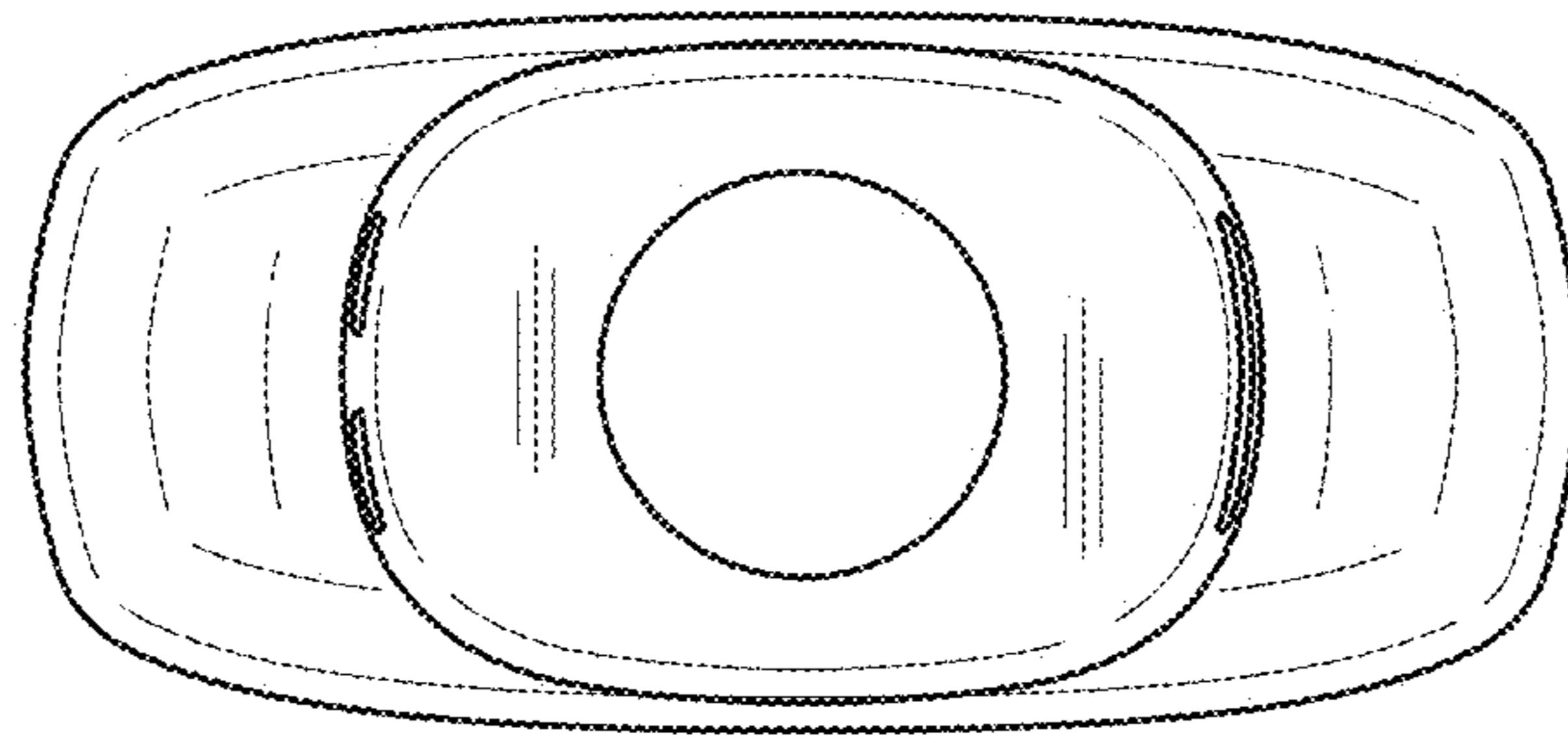

FIG. 4

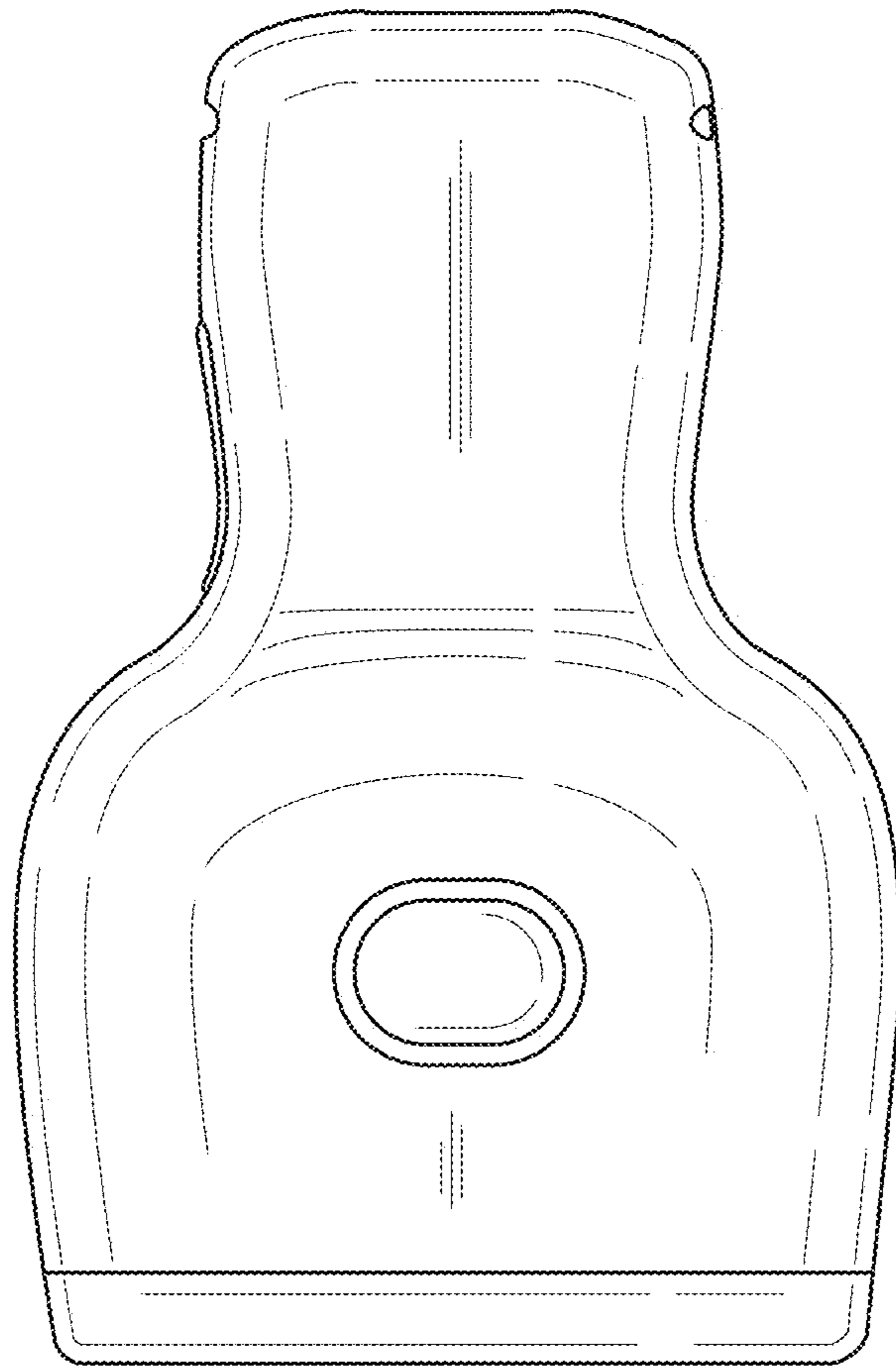

FIG. 5

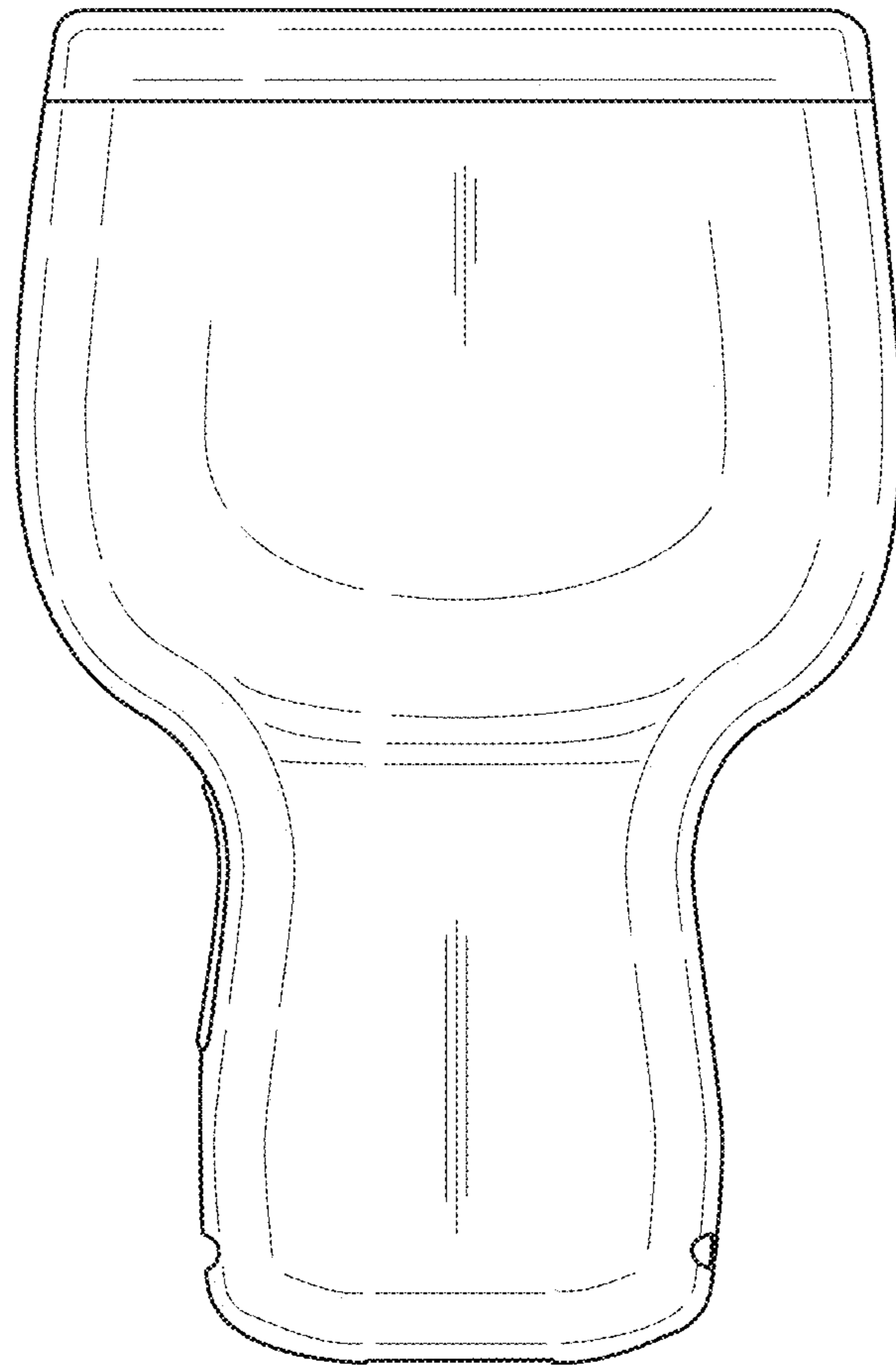

FIG. 6

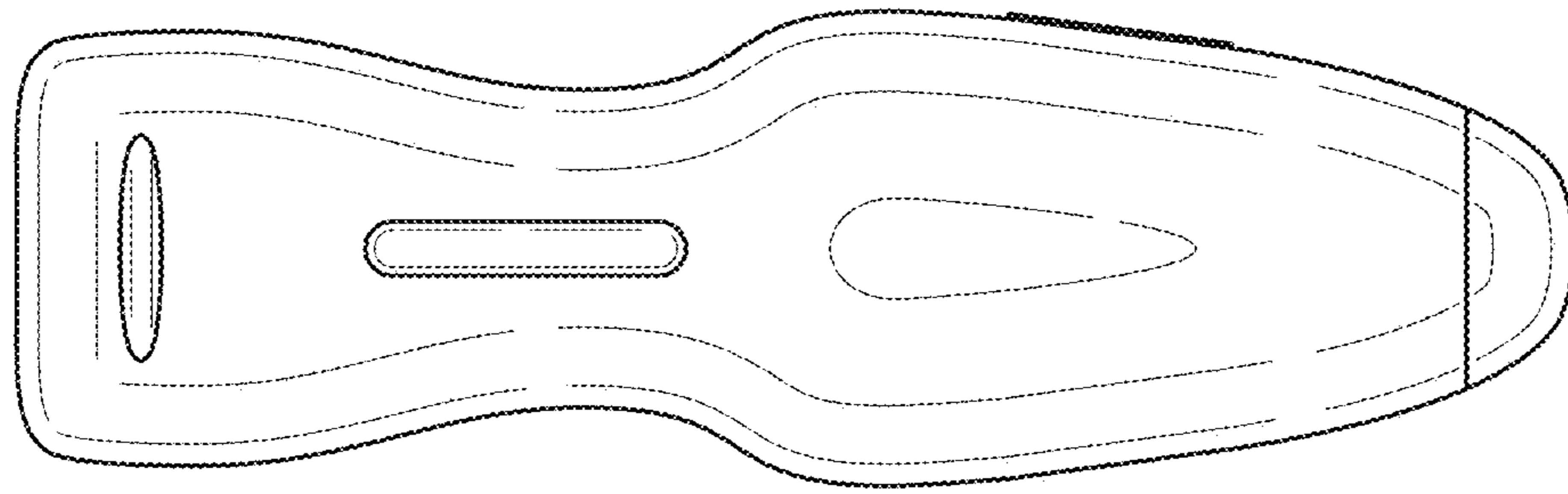

FIG. 7

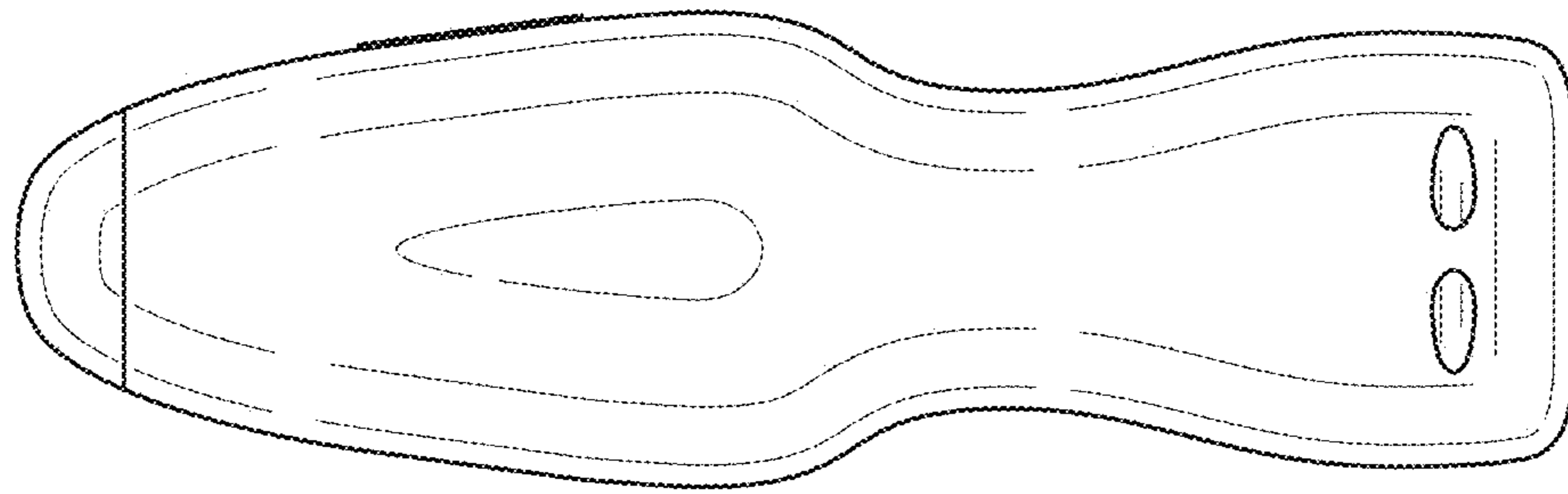

FIG. 8