



US00D948585S

(12) **United States Design Patent**  
**Newgent**

(10) **Patent No.:** **US D948,585 S**

(45) **Date of Patent:** **\*\* Apr. 12, 2022**

(54) **REEL STAND**

(71) Applicant: **James Newgent**, Magnolia, TX (US)

(72) Inventor: **James Newgent**, Magnolia, TX (US)

(\*\*) Term: **15 Years**

(21) Appl. No.: **29/685,464**

(22) Filed: **Mar. 28, 2019**

(51) **LOC (13) Cl.** ..... **15-09**

(52) **U.S. Cl.**

USPC ..... **D15/141**; D15/140; D15/199

(58) **Field of Classification Search**

USPC ..... D34/31; D21/686, 690, 691; D15/28,  
D15/138, 140, 141, 199

CPC ..... B65H 49/32; A63B 21/062; A63B 21/078;  
A63B 21/0783; A63B 21/4035; A63B  
71/0036

See application file for complete search history.

(56) **References Cited**

**U.S. PATENT DOCUMENTS**

|           |      |         |                    |                          |
|-----------|------|---------|--------------------|--------------------------|
| 1,837,175 | A *  | 12/1931 | Stuebing, Jr. .... | B65H 49/32<br>242/129.6  |
| 2,693,916 | A *  | 11/1954 | Pike .....         | B65H 49/32<br>242/598.4  |
| 2,957,644 | A *  | 10/1960 | Beardslee .....    | B65H 49/32<br>242/594.6  |
| 3,304,060 | A *  | 2/1967  | Davenport .....    | B21C 47/24<br>254/131    |
| 4,302,009 | A *  | 11/1981 | Johnson .....      | A63B 21/4029<br>482/104  |
| 6,086,013 | A *  | 7/2000  | Looney, Jr. ....   | B65H 49/321<br>242/129.5 |
| D454,930  | S *  | 3/2002  | Novak .....        | D21/686                  |
| 9,187,289 | B1 * | 11/2015 | Jordan .....       | B65H 49/325              |
| D785,732  | S *  | 5/2017  | Moschel .....      | D21/690                  |

|              |      |         |                 |                          |
|--------------|------|---------|-----------------|--------------------------|
| D806,188     | S *  | 12/2017 | Petek .....     | D21/686                  |
| D819,148     | S *  | 5/2018  | Smith, Jr. .... | D21/690                  |
| D882,707     | S *  | 4/2020  | Brown .....     | D21/686                  |
| 2003/0108391 | A1 * | 6/2003  | Essay .....     | B65H 49/305<br>405/154.1 |
| 2008/0223970 | A1 * | 9/2008  | Taylor .....    | B65H 49/325<br>242/390   |
| 2014/0175213 | A1 * | 6/2014  | Thompson .....  | B65H 49/32<br>242/598.3  |
| 2019/0389686 | A1 * | 12/2019 | Newgent .....   | B65H 59/06               |

**OTHER PUBLICATIONS**

Reel Donkey, Untitled Post No. 205250313003295, (Image uploaded Feb. 11, 2014), Facebook.com, URL:<<https://www.facebook.com/Reel-Donkey-205250313003295/photos/ms.c.eJwzMjA1s7Q0MrE0Mz11MLPQM4LwTY0sTS1MDAzhfDMjS0NzYxMA5xYJnw~.bps.a.205699062958420/205699252958401/>> (Year: 2014).\*

(Continued)

*Primary Examiner* — Calvin E Vansant

*Assistant Examiner* — Mark T. Philipps

(74) *Attorney, Agent, or Firm* — Law Office of Jeff Williams PLLC; J. Oliver Williams

(57) **CLAIM**

The ornamental design for a reel stand, as shown.

**DESCRIPTION**

FIG. 1 is a front perspective view of a reel stand according to the present application.

FIG. 2 is a front view of the reel stand of FIG. 1.

FIG. 3 is a rear view of the reel stand of FIG. 1.

FIG. 4 is a right view of the reel stand of FIG. 1.

FIG. 5 is a left view of the reel stand of FIG. 1.

FIG. 6 is a top view of the reel stand of FIG. 1; and,

FIG. 7 is a bottom view of the reel stand of FIG. 1.

**1 Claim, 7 Drawing Sheets**

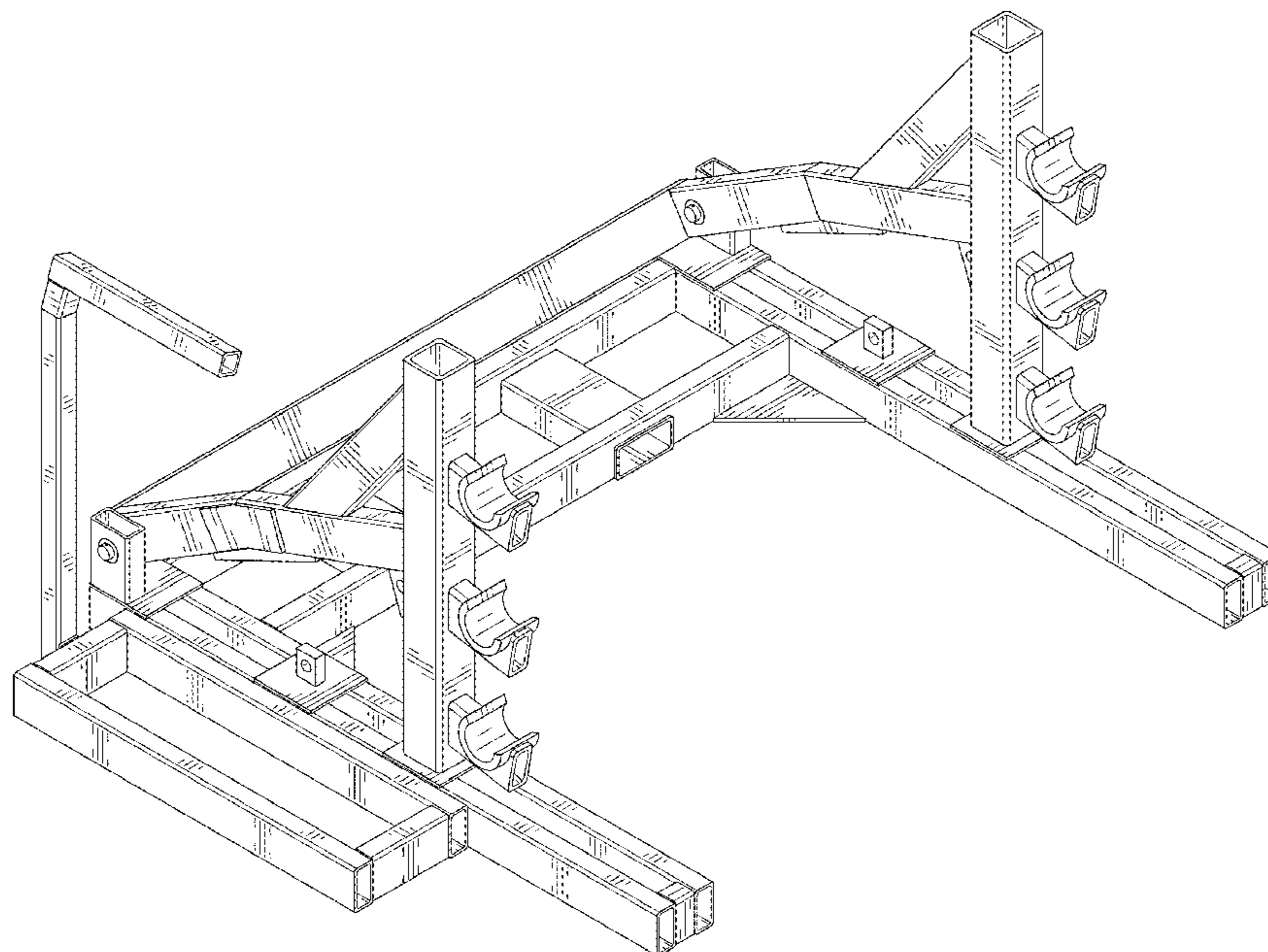

(56)

**References Cited**

OTHER PUBLICATIONS

Georgia Underground Superstore, GUS Reel Buck Cable Spool Holder, (site visited Nov. 19, 2021), GeorgiaUnderground.net website, URL:<<https://georgiaunderground.net/products/gus-reel-buck-cable-spool-holder.html>> (Year: 2021).\*

Mechtrix, Wire Reel Stands; Heavy Duty Reel Stand, (site visited Nov. 19, 2021), Mechtrix.com website, URL:<<https://www.mechtrix.com/equipment/reel-stands/>> (Year: 2021).\*

\* cited by examiner

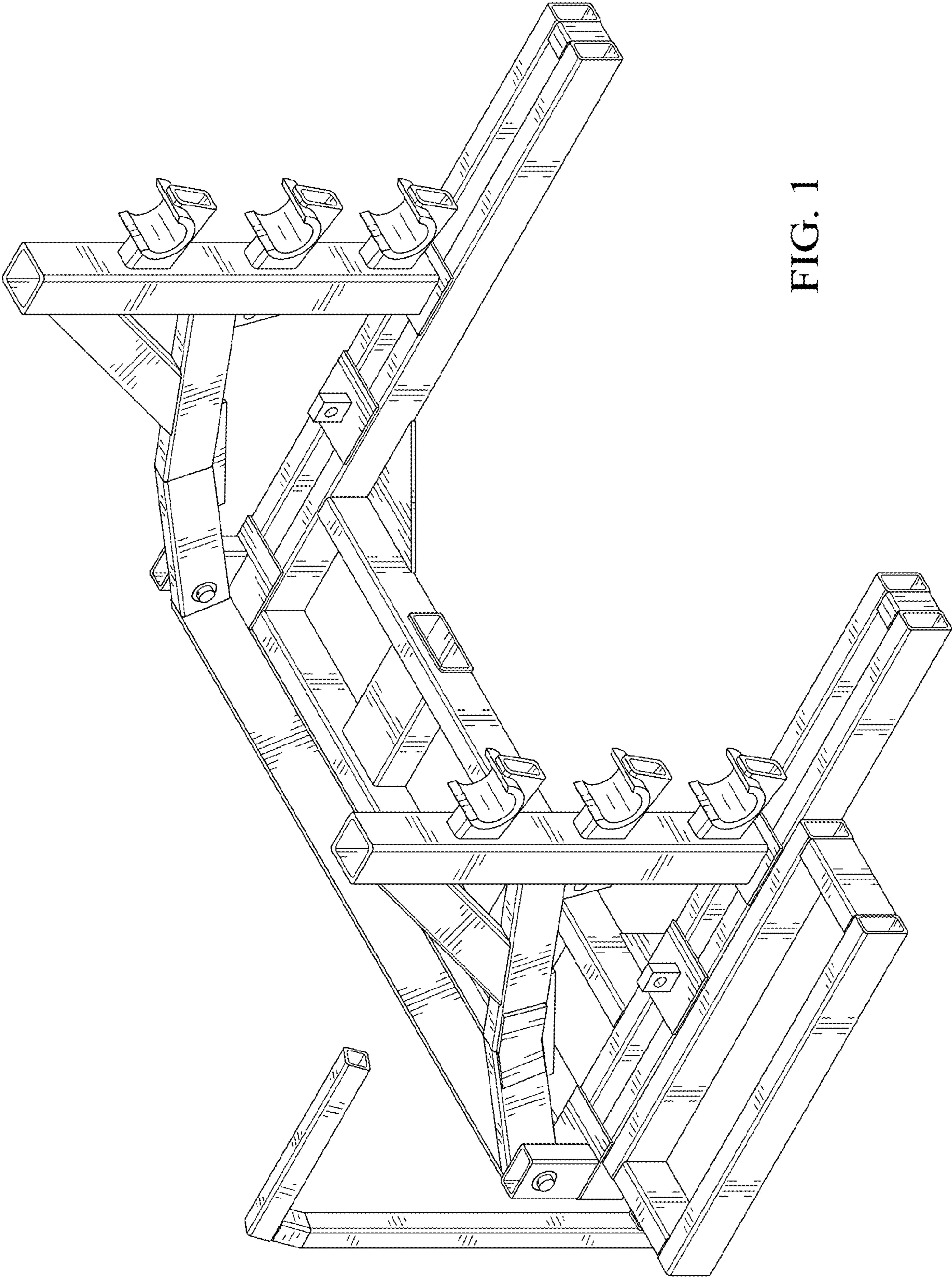

FIG. 1

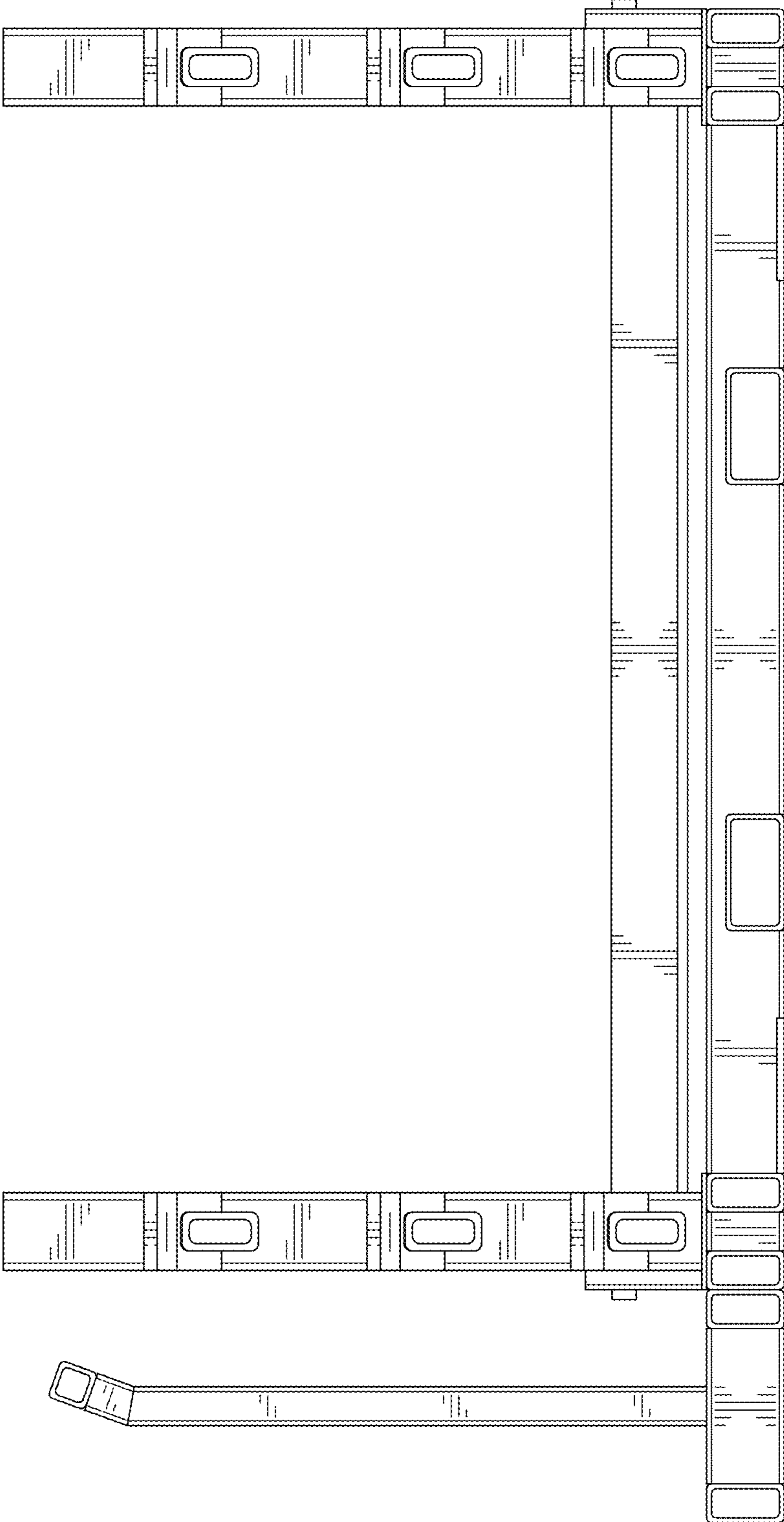

FIG. 2

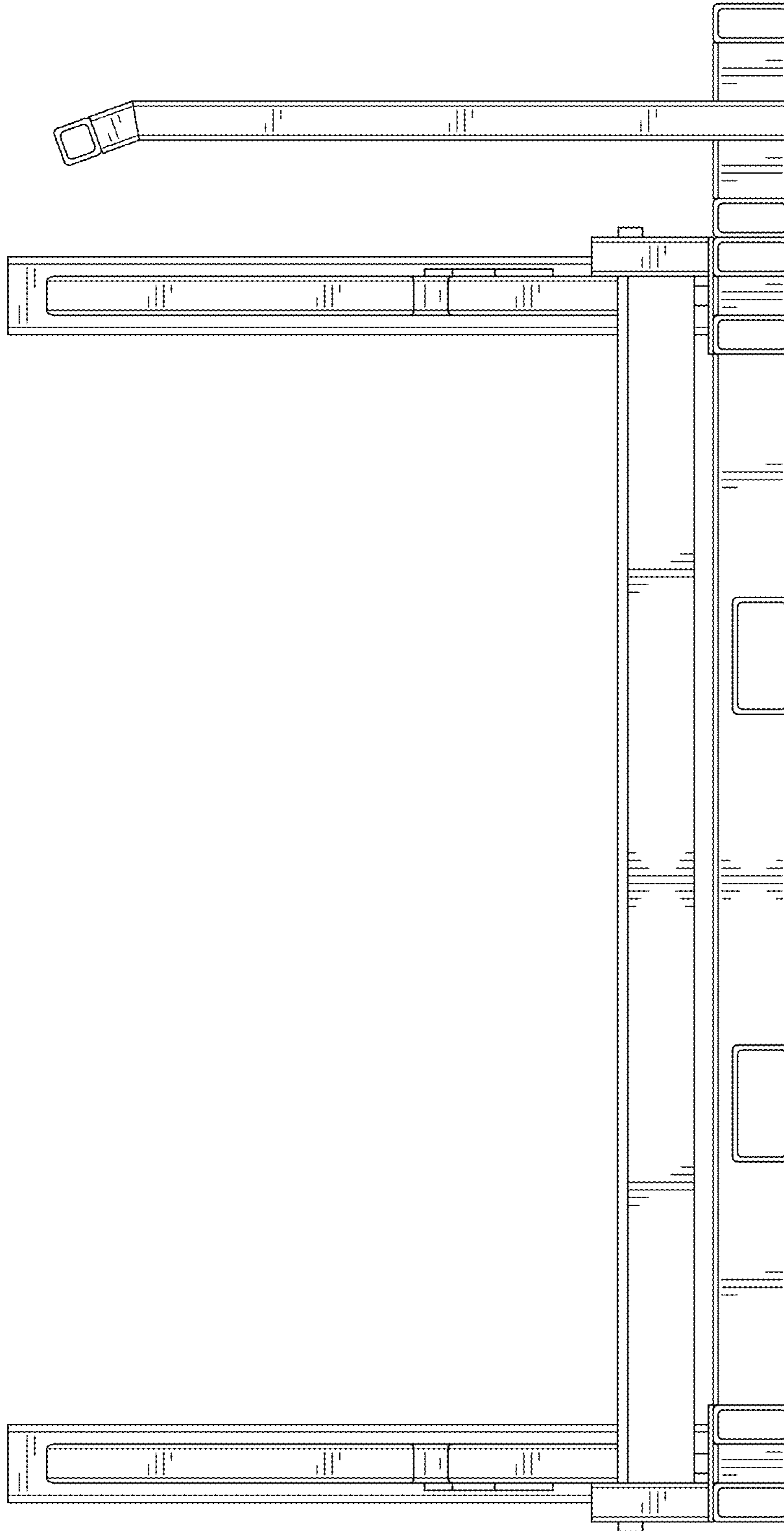

FIG. 3

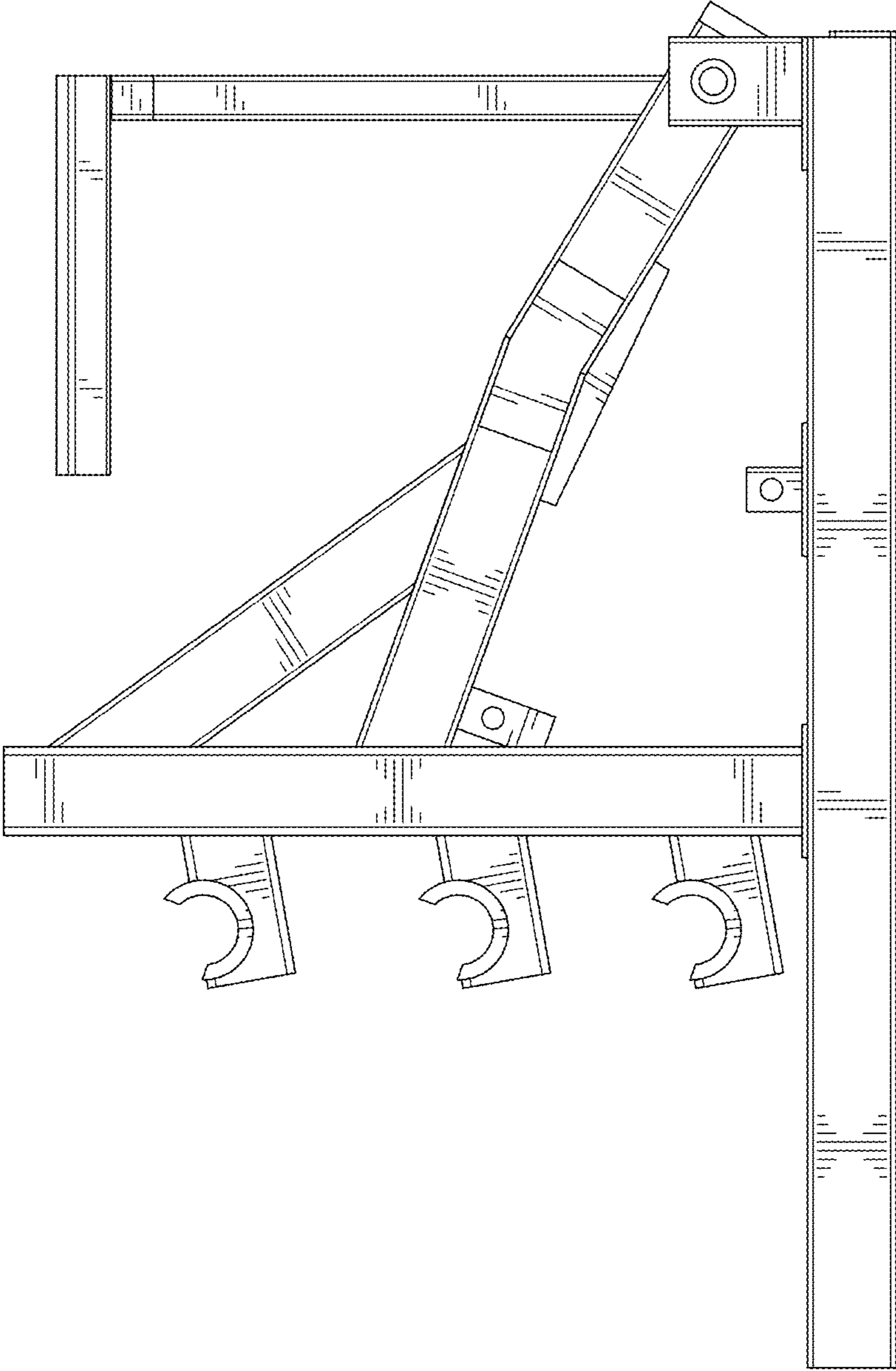

FIG. 4

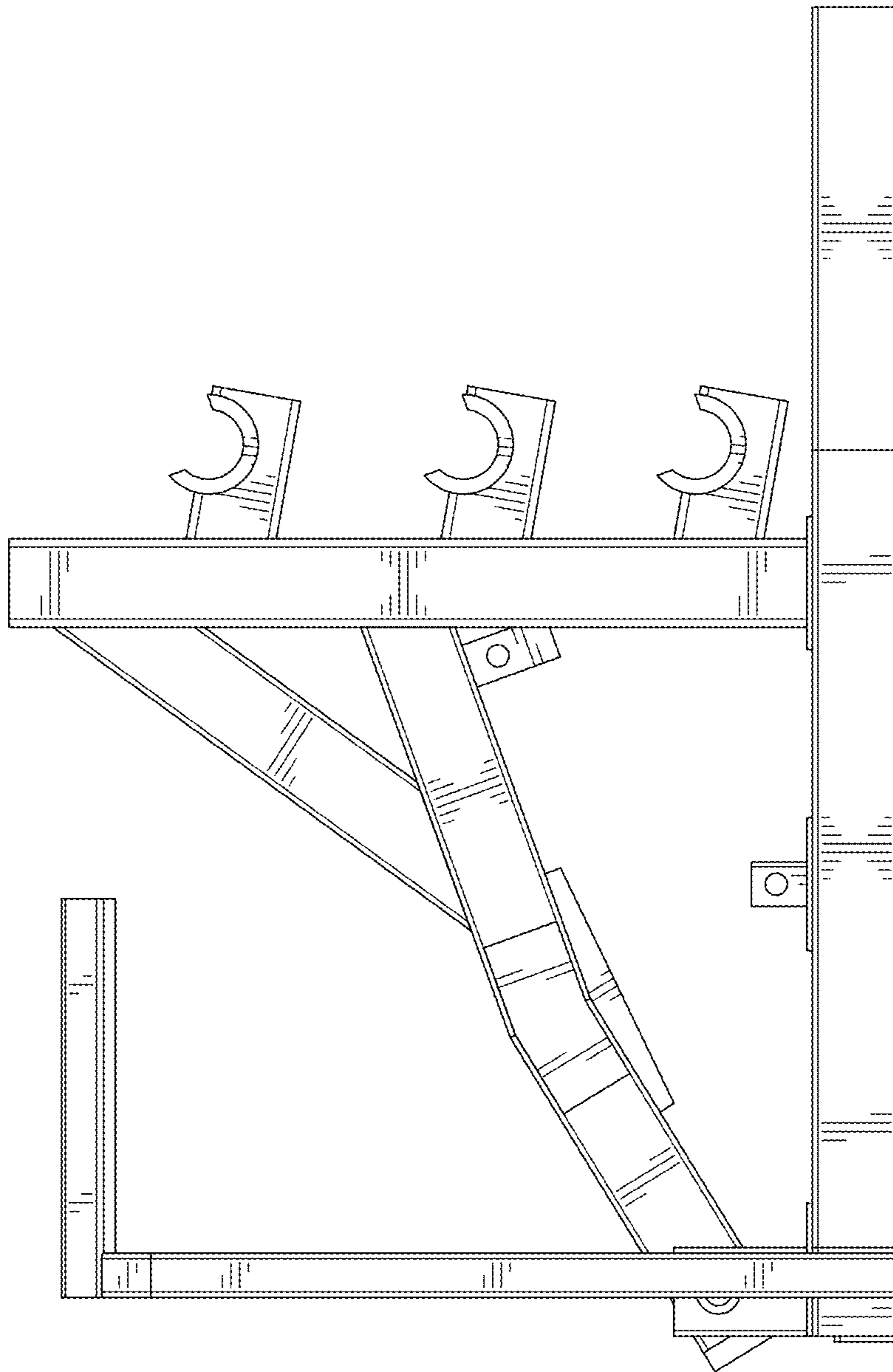

FIG. 5

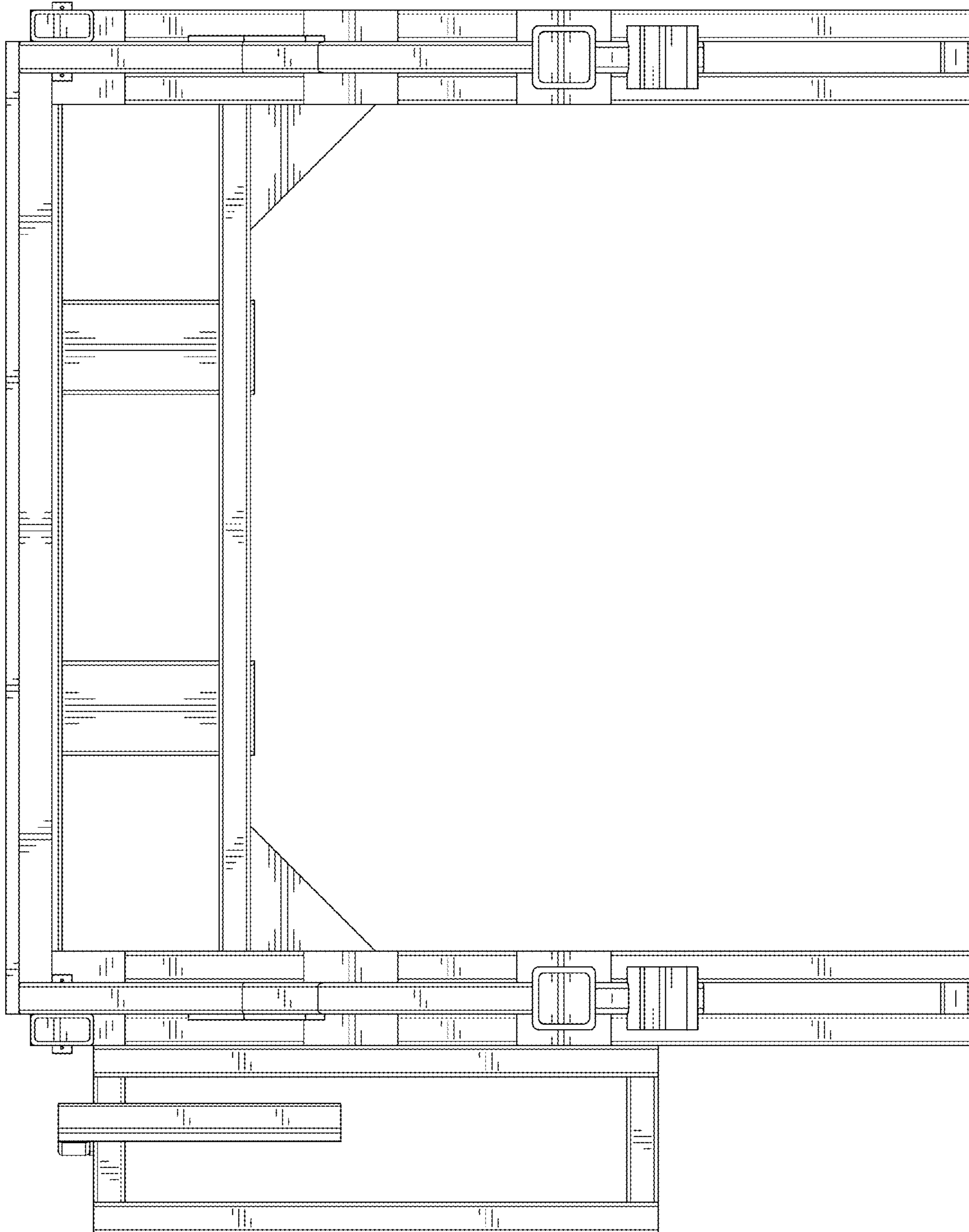

FIG. 6



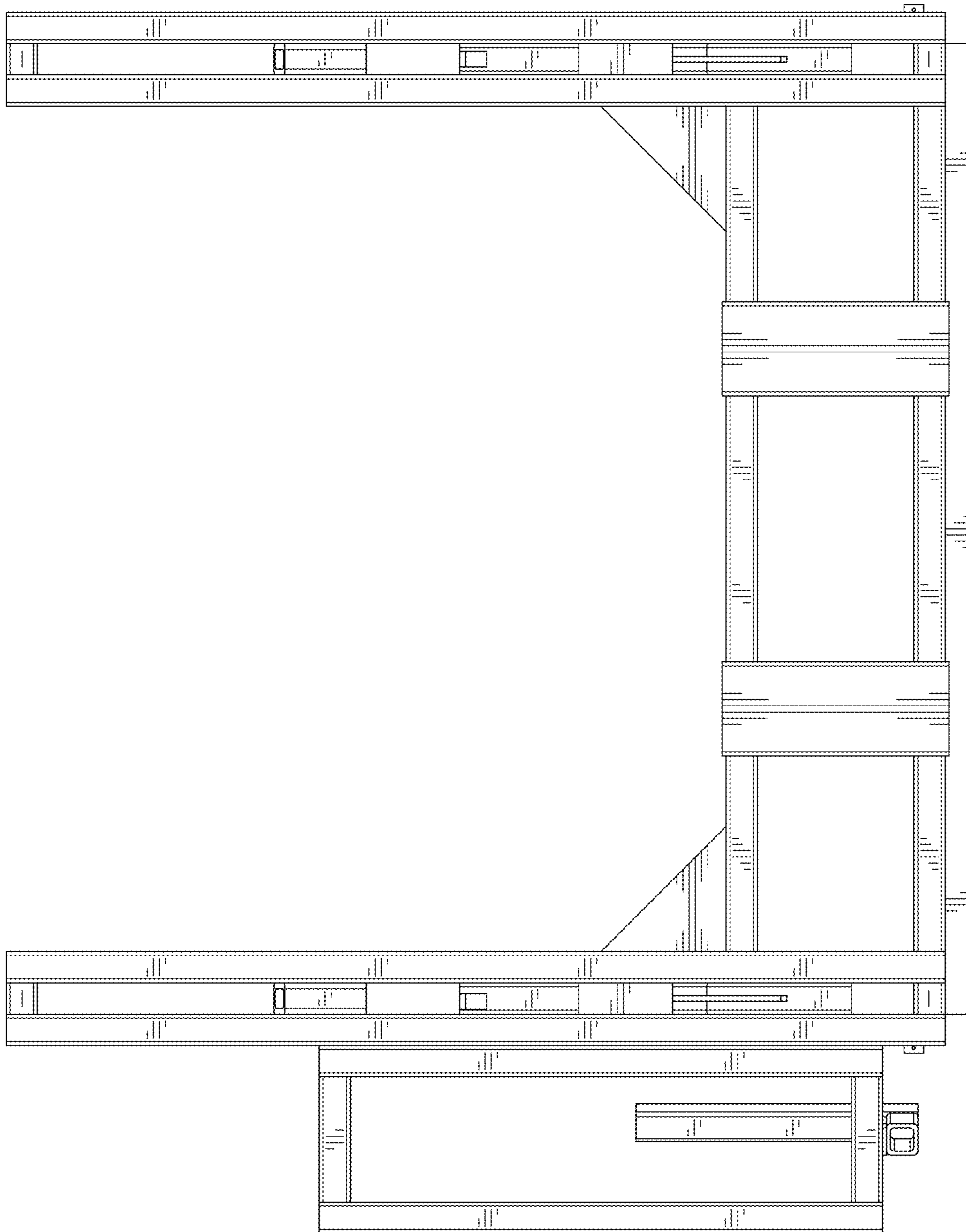

FIG. 7