



US00D948561S

(12) **United States Design Patent** (10) **Patent No.:** **US D948,561 S**  
**O’Neal et al.** (45) **Date of Patent:** **\*\* Apr. 12, 2022**

(54) **DISPLAY SCREEN WITH AN ANIMATED GRAPHICAL USER INTERFACE**

FOREIGN PATENT DOCUMENTS

(71) Applicant: **Under Armour, Inc.**, Baltimore, MD (US)

CN 304593331 \* 4/2018

(72) Inventors: **Jeff O’Neal**, Austin, TX (US); **Mayank Arora**, Austin, TX (US); **Travis Rimel**, Austin, TX (US); **Daniel Townson**, Austin, TX (US); **Pedro Feitosa**, Austin, TX (US); **William Kluss**, Austin, TX (US); **Daniel Sargeant**, Austin, TX (US)

OTHER PUBLICATIONS

Novelo, Karen “Hi” Jun. 27, 2018, Dribbble, site visited Apr. 13, 2021: <https://dribbble.com/shots/4757626-Hi> (Year: 2018).\*

(Continued)

(73) Assignee: **Under Armour, Inc.**, Baltimore, MD (US)

*Primary Examiner* — Jack Reickel

*Assistant Examiner* — Christopher M Spivey

(74) *Attorney, Agent, or Firm* — Maginot, Moore & Beck LLP

(\*\*) Term: **15 Years**

(57) **CLAIM**

The ornamental design for a display screen with an animated graphical user interface, as shown and described.

(21) Appl. No.: **29/700,095**

**DESCRIPTION**

(22) Filed: **Jul. 31, 2019**

(51) **LOC (13) Cl.** ..... **14-04**

(52) **U.S. Cl.**  
USPC ..... **D14/489**

(58) **Field of Classification Search**  
USPC ..... D14/485–495; D18/24–33  
CPC ..... G06F 3/167; G06F 17/211; G06F 17/212;  
G06F 3/048; G06F 3/0481; G06F 3/04817; G06F 3/0482; G06F 3/0483;  
G06F 3/04842; G06F 3/0485; G06F 3/04855; G06F 3/0486; G06F 3/0488;  
G06F 3/04886;

FIG. 1 is a front view of a first image in a sequence for a first embodiment of a display screen with an animated graphical user interface showing our new design;

FIG. 2 is a second image thereof; and

FIG. 3 is a third image thereof.

FIG. 4 is a front view of a first image in a sequence for a second embodiment of a display screen with an animated graphical user interface showing our new design;

FIG. 5 is a second image thereof; and,

FIG. 6 is a third image thereof.

In the first embodiment, the appearance of the animated graphical user interface sequentially transitions between the images shown in FIGS. 1-3. In the second embodiment, the appearance of the animated graphical user interface sequentially transitions between the images shown in FIGS. 4-6. The process or period in which one image transitions to another forms no part of the claimed design.

The broken line showing of a display screen and portions of the graphical user interface is included for purposes of illustrating portions of the article only and forms no part of the claimed design.

(Continued)

(56) **References Cited**

U.S. PATENT DOCUMENTS

D536,343 S \* 2/2007 Fong ..... D14/489  
D667,422 S \* 9/2012 Elliott ..... D14/488

(Continued)

**1 Claim, 6 Drawing Sheets**

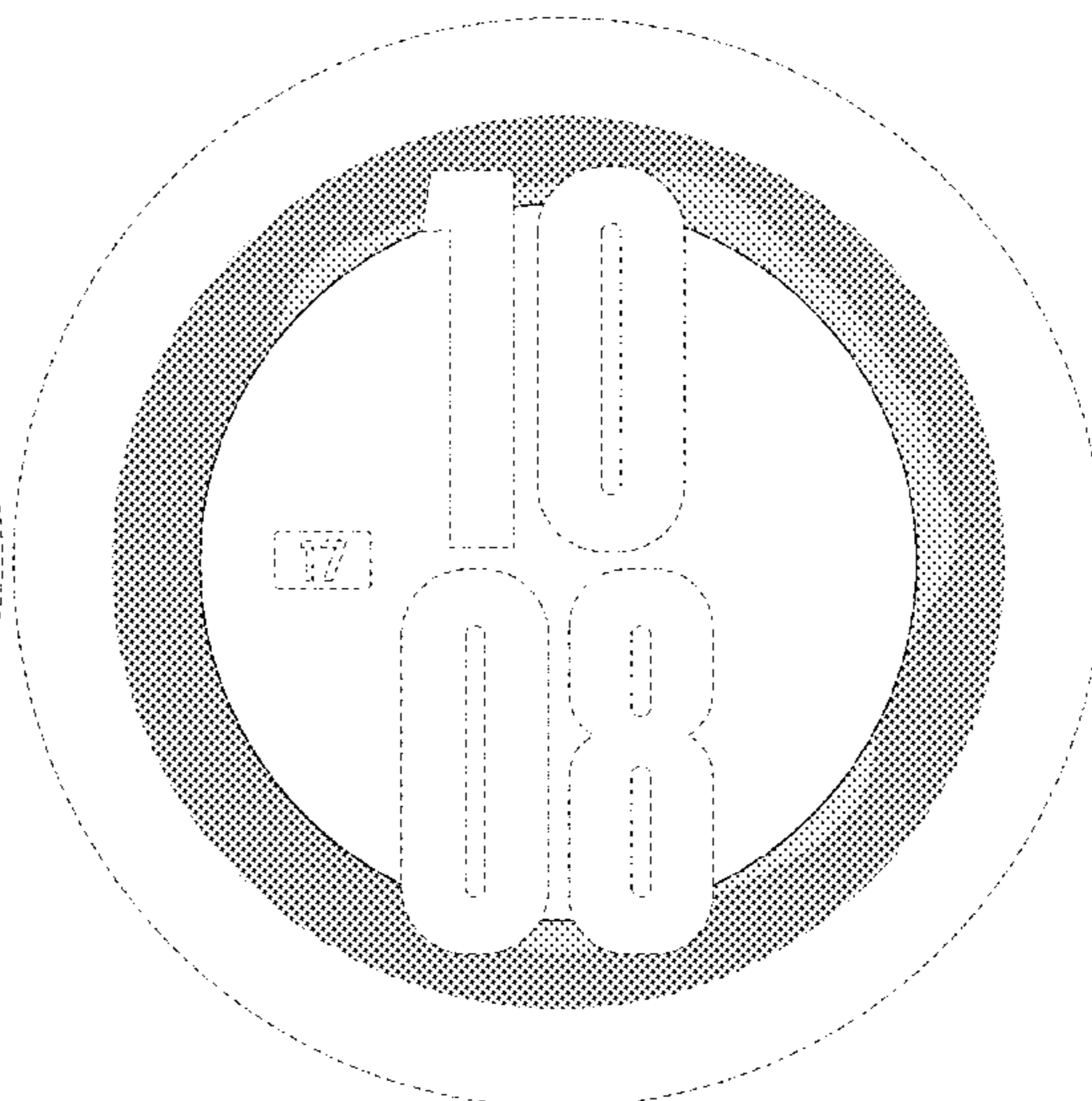
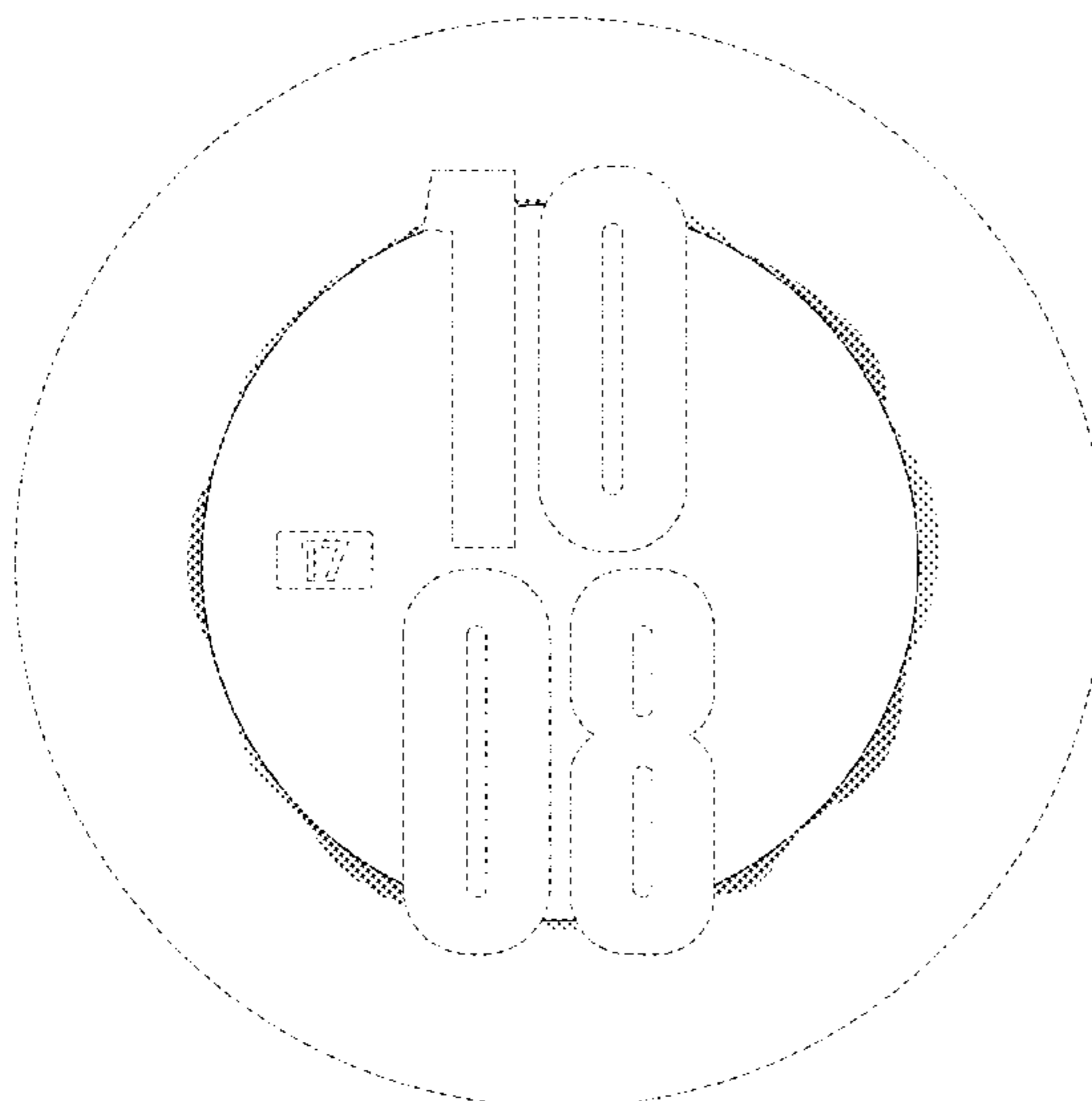

(58) **Field of Classification Search**

CPC .. G06F 3/017; G06F 9/4443; G07F 17/3213;  
 G06T 13/80; G06T 15/02; H04M  
 1/72583; H04M 1/21; H04M 1/0281;  
 G06Q 10/063114; H04N 1/00477; G11B  
 27/34

See application file for complete search history.

(56) **References Cited**

U.S. PATENT DOCUMENTS

D713,414 S \* 9/2014 Lee ..... D14/486  
 D714,322 S \* 9/2014 Pereira ..... D14/485  
 D746,857 S \* 1/2016 Rayit ..... D14/488  
 D760,790 S \* 7/2016 Ishii ..... G06F 3/04817  
 D14/494  
 D763,871 S \* 8/2016 Yang ..... D14/485  
 D786,916 S \* 5/2017 Kim ..... D14/487  
 D809,525 S \* 2/2018 Arabian ..... D14/485  
 D831,067 S \* 10/2018 Ekstrand ..... D14/489  
 D847,156 S \* 4/2019 Bae ..... D14/485  
 D852,217 S \* 6/2019 Li ..... D14/486  
 D852,820 S \* 7/2019 Sanchez ..... D14/485  
 D852,842 S \* 7/2019 Hung ..... D14/488  
 D857,726 S \* 8/2019 Van Gerbig ..... D14/486  
 D860,221 S \* 9/2019 Jeon ..... D14/485  
 D860,222 S \* 9/2019 Cen ..... D14/485  
 D864,225 S \* 10/2019 Xu ..... D14/486  
 D874,497 S \* 2/2020 Krenkler ..... D14/486

D874,499 S \* 2/2020 Krenkler ..... D14/486  
 D874,500 S \* 2/2020 Krenkler ..... D14/486  
 D884,011 S \* 5/2020 Krenkler ..... D14/486  
 D884,012 S \* 5/2020 Krenkler ..... D14/486  
 D890,188 S \* 7/2020 Anno ..... D14/485  
 D892,854 S \* 8/2020 Yoo ..... D14/488  
 D895,646 S \* 9/2020 Sanborn ..... D14/485  
 D897,369 S \* 9/2020 Zurmoehle ..... D14/489  
 10,789,812 B2 \* 9/2020 Sanborn ..... G07F 17/3213  
 D903,711 S \* 12/2020 Saule ..... D14/489  
 D914,043 S \* 3/2021 Van Gerbig ..... D14/486  
 D929,452 S \* 8/2021 Bayliss ..... D14/491  
 2018/0284972 A1 \* 10/2018 Akagawa ..... G06F 3/0481

OTHER PUBLICATIONS

“Huami Amazfit Verge in English—Xiaomi’s new affordable AMOLED SmartWatch!” Dec. 25, 2018, YouTube, site visited Feb. 19, 2021: <https://www.youtube.com/watch?v=IHYqvKyia24> (Year: 2018).\*

“Samsung Galaxy Watch Active 2—Under Armour Special Edition Available!” Aug. 9, 2019, YouTube, site visited Jul. 14, 2021: <https://www.youtube.com/watch?v=IHYqvKyia24> (Year: 2018).\*

“Hyundai ces 2017 UX Concept” Apr. 12, 2017, BeHance, site visited Jul. 14, 2021: <https://www.behance.net/gallery/51451427/Hyundai-ces-2017-UX-Concept> (Year: 2017).\*

Lee, Jay “Circle Music” May 31, 2017, BeHance, site visited Jul. 14, 2021: <https://www.behance.net/gallery/52245125/Circle-Music> (Year: 2017).\*

\* cited by examiner

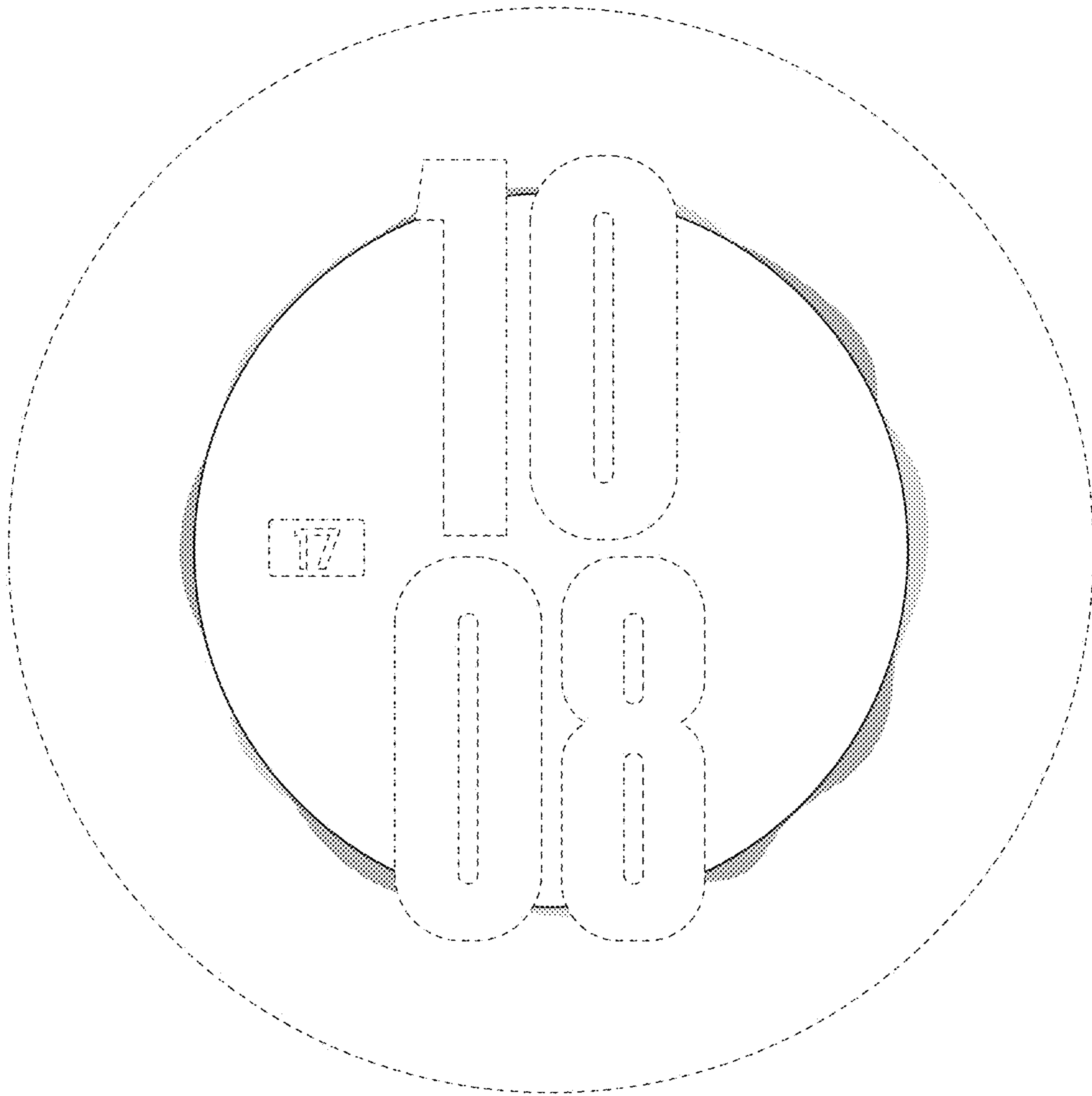

**FIG. 1**

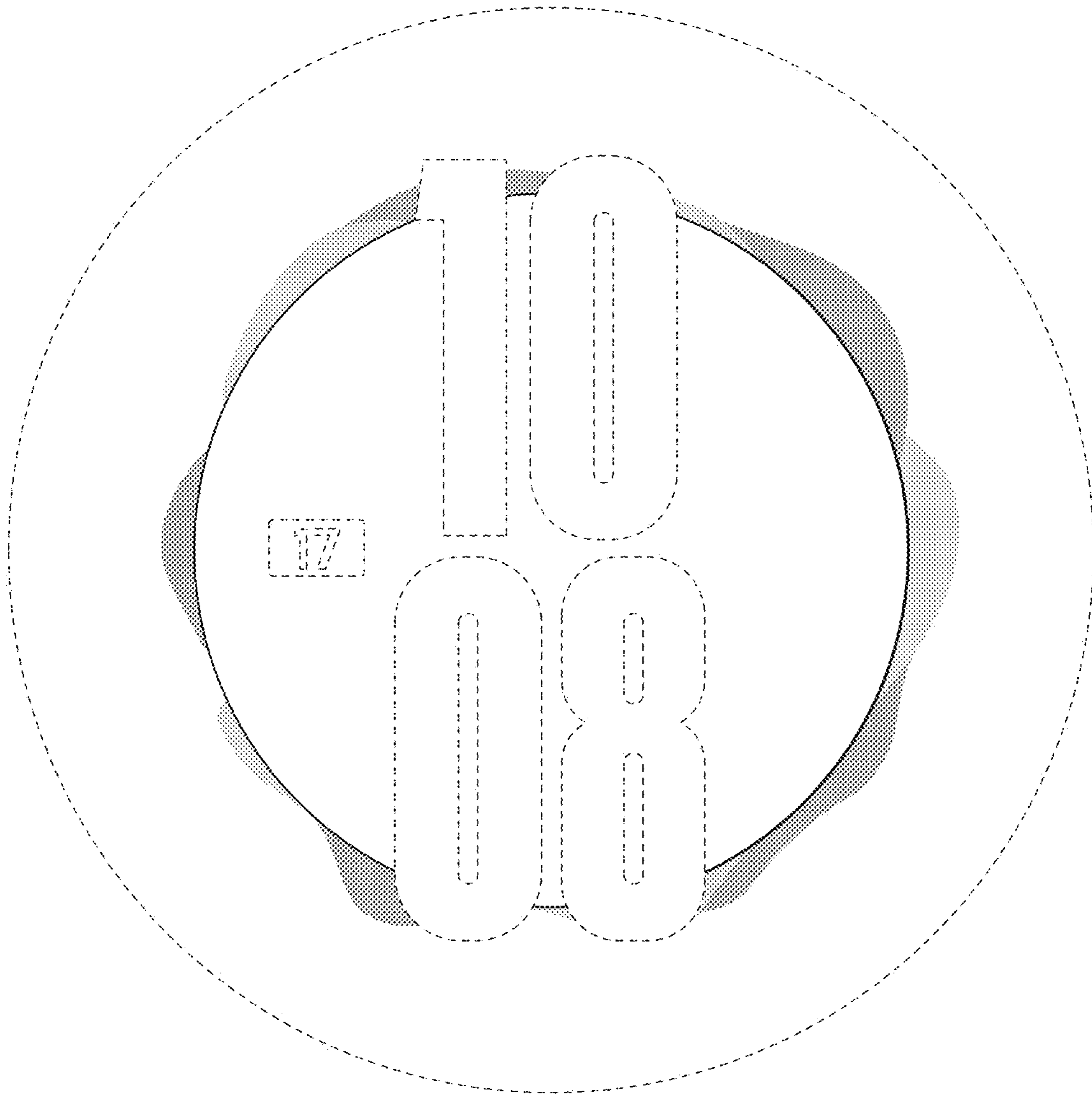

**FIG. 2**

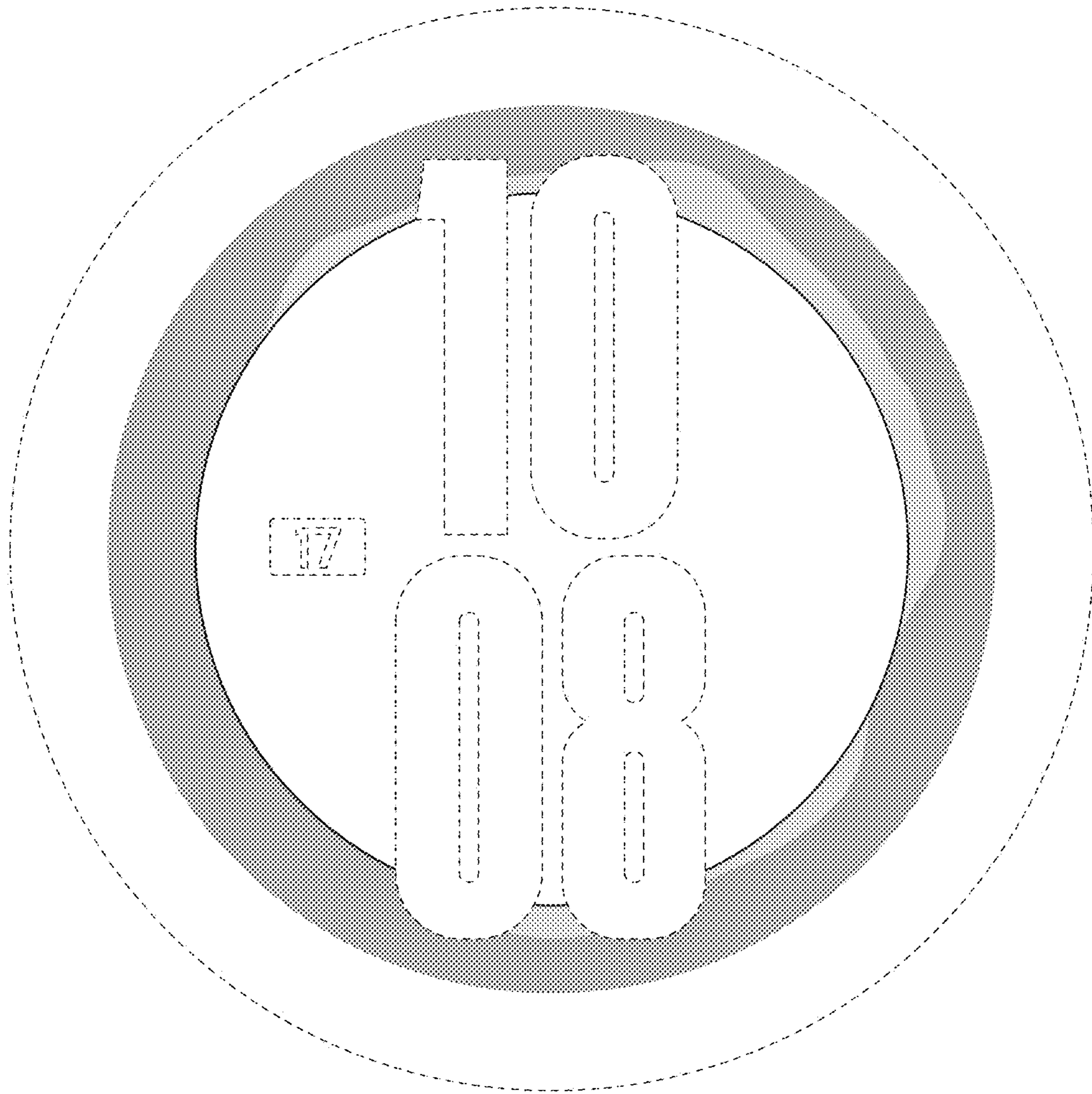
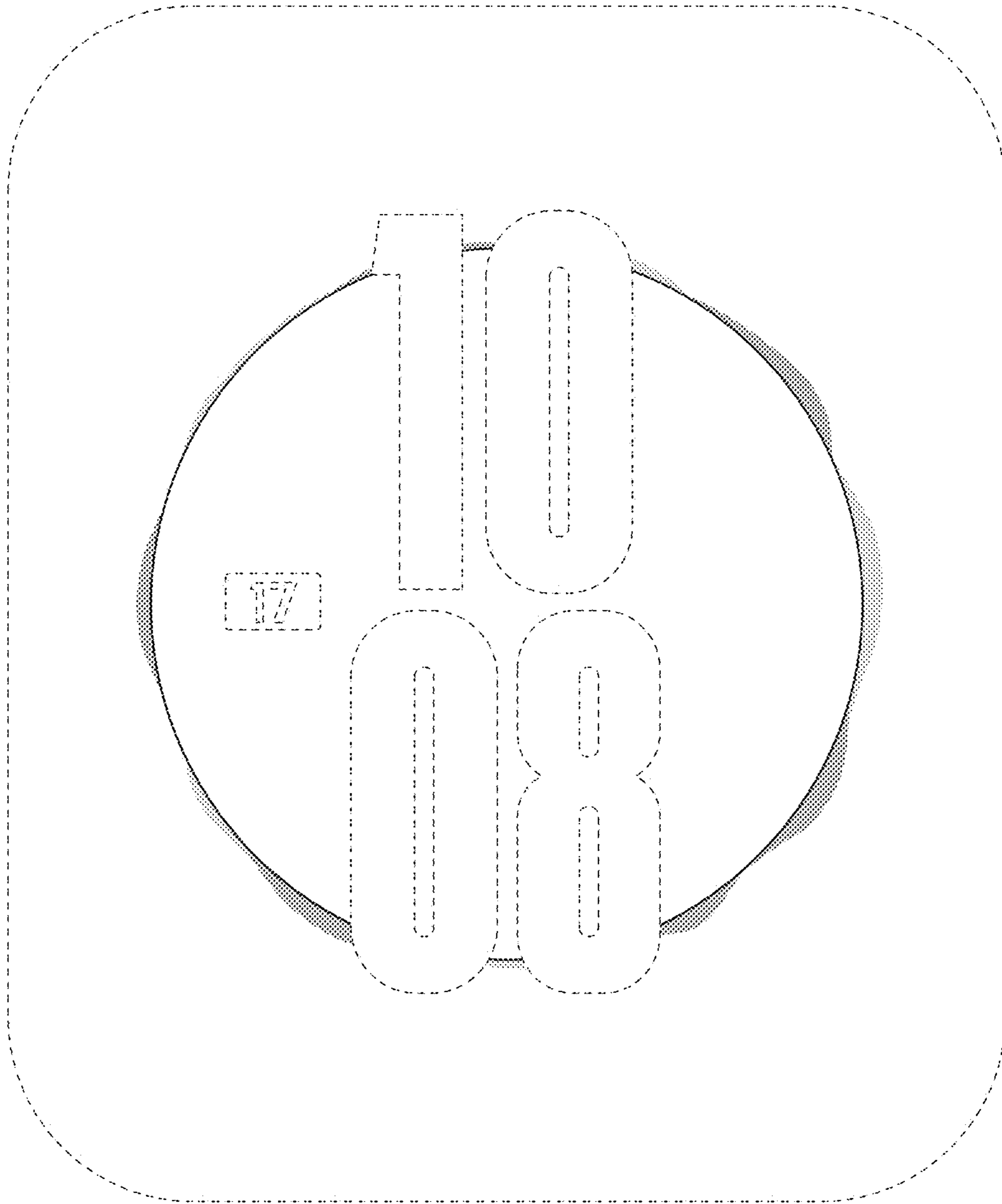
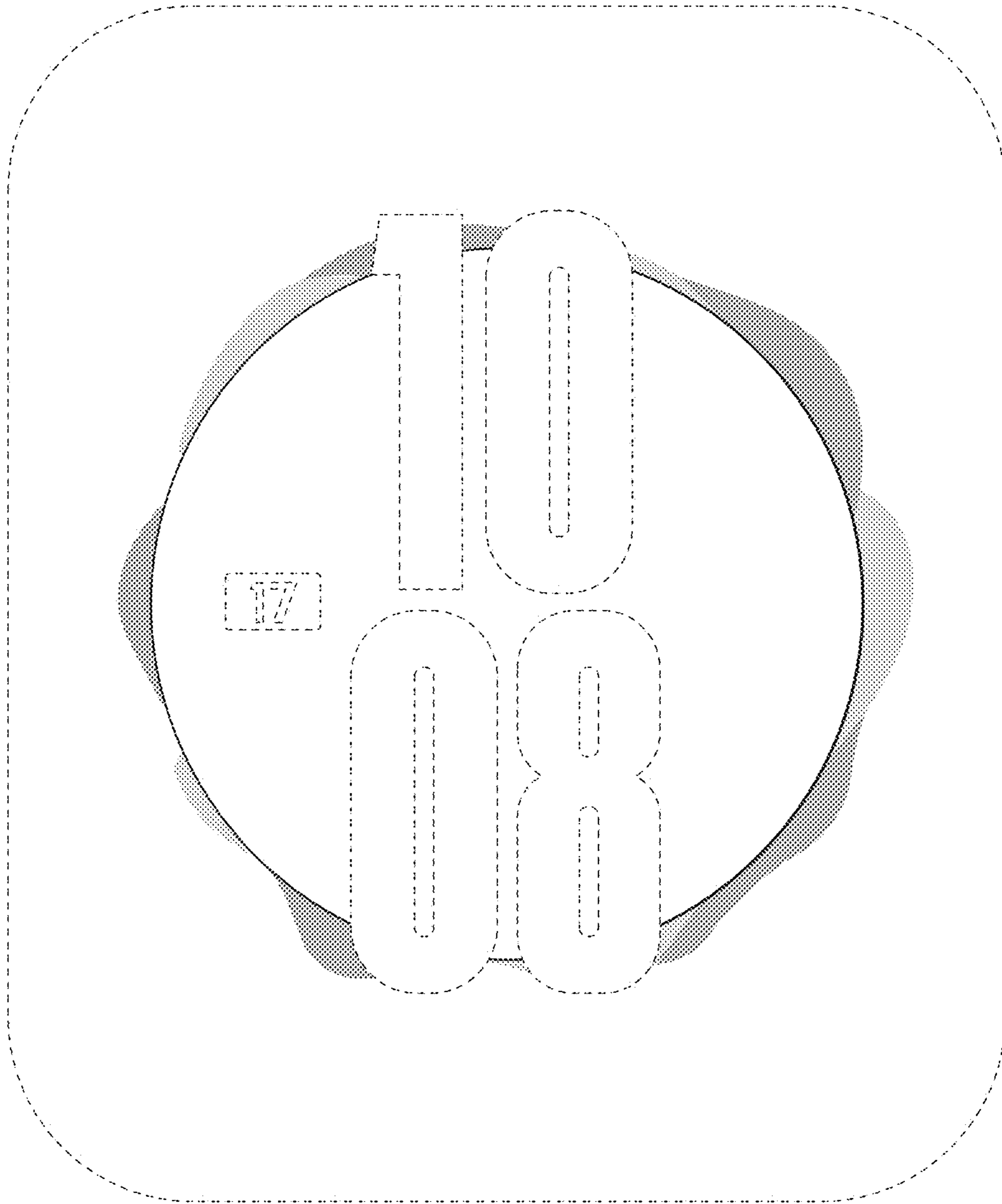

FIG. 3



**FIG. 4**



**FIG. 5**

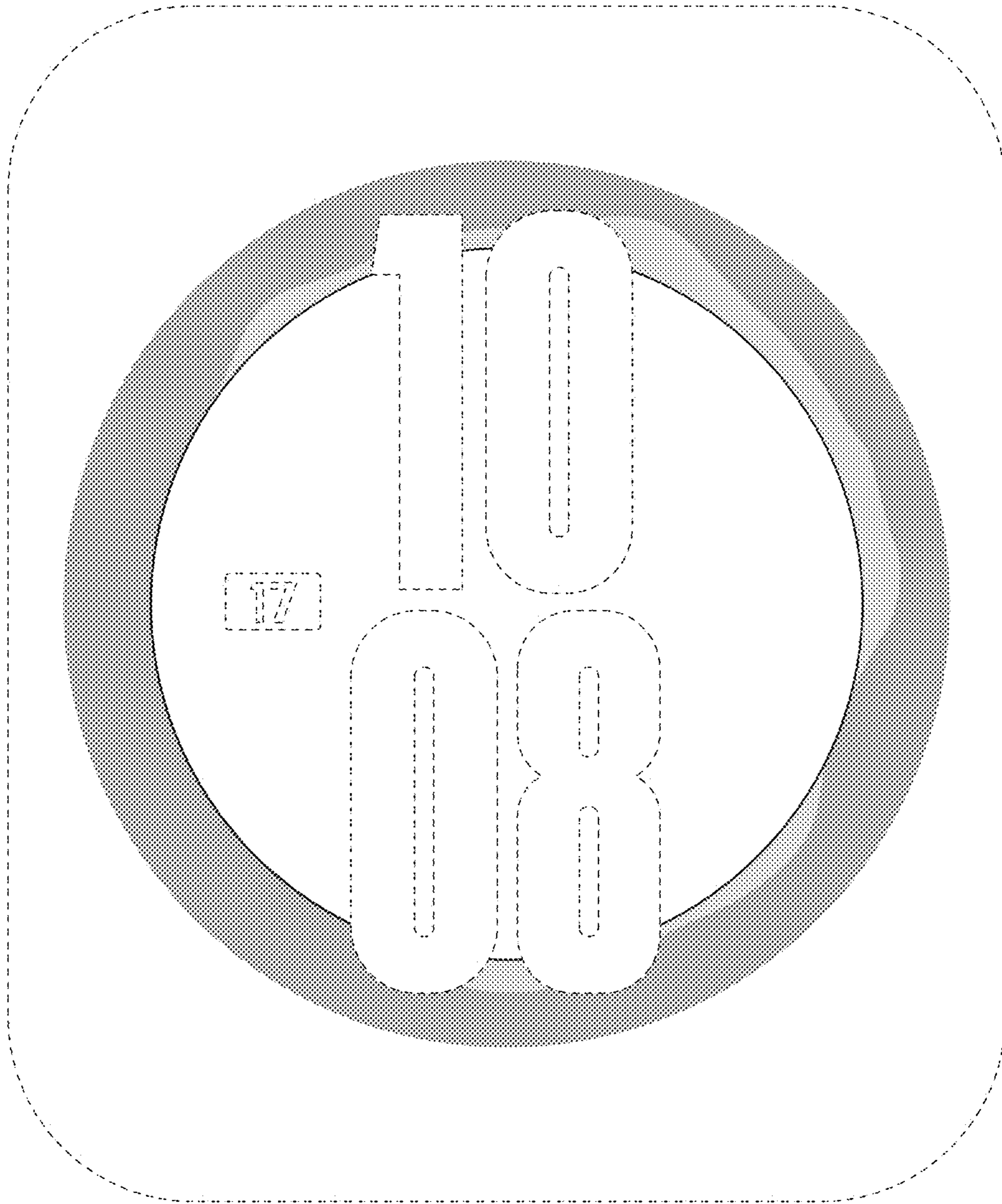

**FIG. 6**