



US00D948317S

(12) **United States Design Patent** (10) **Patent No.:** **US D948,317 S**
Wruck et al. (45) **Date of Patent:** **** Apr. 12, 2022**

(54) **FUEL HOSE REEL MOUNT**
(71) Applicant: **Westmor Industries, LLC**, Morris, MN (US)
(72) Inventors: **Abe Wruck**, Morris, MN (US); **Meranda Hennen**, Morris, MN (US)
(73) Assignee: **Westmor Industries, LLC**, Morris, MN (US)

D709,803 S * 7/2014 Lancaster D12/162
9,352,933 B2 5/2016 Moore et al.
D772,116 S * 11/2016 Wu D12/162
D794,519 S * 8/2017 McMath D12/171
(Continued)

(**) Term: **15 Years**

FOREIGN PATENT DOCUMENTS

DE 202011103102 U1 12/2012
EP 2330065 B1 9/2013
(Continued)

(21) Appl. No.: **29/687,216**
(22) Filed: **Apr. 11, 2019**
(51) **LOC (13) Cl.** **08-05**
(52) **U.S. Cl.** **D8/358**
USPC **D8/358**
(58) **Field of Classification Search**
USPC D08/358–359, 360.1, 363, 356, 373, 375,
D08/380, 396; D12/159–164, 167, 168,
D12/172, 400, 406
CPC B65H 2701/34; B65H 2701/33; B65H
75/4471; B65H 2701/32; B65H 2701/332;
B65H 75/40; B65H 75/425; B65H
75/4481
See application file for complete search history.

OTHER PUBLICATIONS

Rebel Off Road Summit Series Front Bumper, Date Visited: Jun. 1, 2021, Rebel Off Road, Date Available: Jun. 1, 2021, <https://rebeloffroad.com/blog/rebel-off-road-summit-series-front-bumper-whoop-skid-jljl/> (Year: 2021).*
(Continued)

Primary Examiner — Susan Bennett Hattan
Assistant Examiner — Elizabeth S Ko
(74) *Attorney, Agent, or Firm* — Todd R. Fronck; Larkin Hoffman Daly & Lindgren, Ltd.

(57) **CLAIM**

The ornamental design for a fuel hose reel mount, as shown and described.

DESCRIPTION

FIG. 1 is a front elevation view of a fuel hose reel mount showing our new design;
FIG. 2 is a rear elevation view thereof;
FIG. 3 is a left elevation view thereof;
FIG. 4 is a right elevation view thereof;
FIG. 5 is a top plan view thereof; and,
FIG. 6 is a bottom view thereof.
The broken lines shown in the drawings illustrate portions of the fuel hose reel mount that form no part of the claimed design.

(56) **References Cited**
U.S. PATENT DOCUMENTS
3,829,064 A 8/1974 Jackson
D257,430 S * 10/1980 Hickey D12/171
5,495,995 A 3/1996 Dominique et al.
6,059,214 A 5/2000 Rashidi et al.
D433,970 S * 11/2000 McCoy D12/162
D434,354 S * 11/2000 McCoy D12/162
7,150,425 B2 12/2006 Banaszkiwicz et al.
D551,947 S 10/2007 Metzger
D551,948 S 10/2007 Metzger
7,475,841 B2 1/2009 Fancher
D682,750 S * 5/2013 Smith D12/162

1 Claim, 6 Drawing Sheets

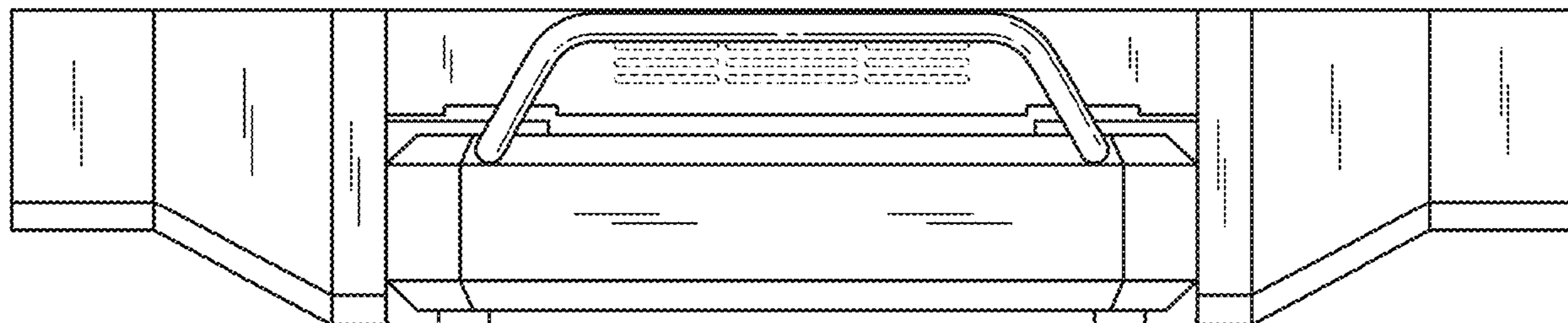

(56)

References Cited

OTHER PUBLICATIONS

U.S. PATENT DOCUMENTS

D813,784 S * 3/2018 Larsson D12/407
 D814,386 S * 4/2018 Carswell D12/400
 D821,288 S * 6/2018 Huang D12/406
 D827,520 S * 9/2018 Wu D12/172
 D832,161 S * 10/2018 Kobayashi D12/171
 D833,922 S * 11/2018 DiCanzio D12/163
 D869,349 S * 12/2019 Wu D12/162
 D881,790 S * 4/2020 Ni D12/406
 D881,791 S * 4/2020 Ni D12/406
 D885,303 S * 5/2020 Me D12/406
 D886,707 S * 6/2020 Stoneburner D12/406
 D890,685 S * 7/2020 Chen D12/406
 D896,139 S * 9/2020 Williams D12/171
 2004/0200921 A1 10/2004 Chapman et al.
 2006/0289844 A1* 12/2006 McFarland B66D 1/00
 254/264
 2011/0255947 A1* 10/2011 Scuito B66D 3/26
 414/800
 2013/0161438 A1 6/2013 Van Der Paal
 2014/0021328 A1* 1/2014 Higgs B66D 1/00
 248/674
 2015/0129703 A1 5/2015 Kucera
 2016/0340157 A1* 11/2016 Biedrzycki B66D 1/28
 2019/0375338 A1* 12/2019 Deninno B60R 9/10

FOREIGN PATENT DOCUMENTS

EP 2512966 B1 2/2018
 WO 2018213878 A1 11/2018

Front Bumpers Offer Almost Unlimited Customization, Date Visited: Jun. 1, 2021, Fire Apparatus Magazine, Date Available: Mar. 14, 2016, <https://www.fireapparatusmagazine.com/fire-apparatus/front-bumpers-offer-almost-unlimited-customization/#gref> (Year: 2016).*

Westmor Industries “Blueline Bobtails” Brochure, Oct. 2017, 8 pages.

Westmor Industries “Transtech Tank, Model HCT” Brochure, Dec. 2016, 2 pages.

Petrillo, Alan M., “Handline Options for Engine Companies” Fire Apparatus Magazine, Issue 8 Vol. 22, Aug. 23, 2017, 17 pages. <https://www.fireapparatusmagazine.com/2017/08/03/handline-options-for-engine-companies/#gref>.

JBT “Tempest Aircraft Deicer” Brochure, 2014, 3 pages.

Vac-Con “Hot Shot—Water Jet Machine” Brochure, Jun. 2016, 2 pages.

WECO Industries “GAPVAX MC Series—Vacuum Accessories” Brochure, Oct. 2015, pp. 116-121.

Westmor Industries “5,000 Gallon Jet Refueler” Brochure, Oct. 2017, 2 pages.

* cited by examiner

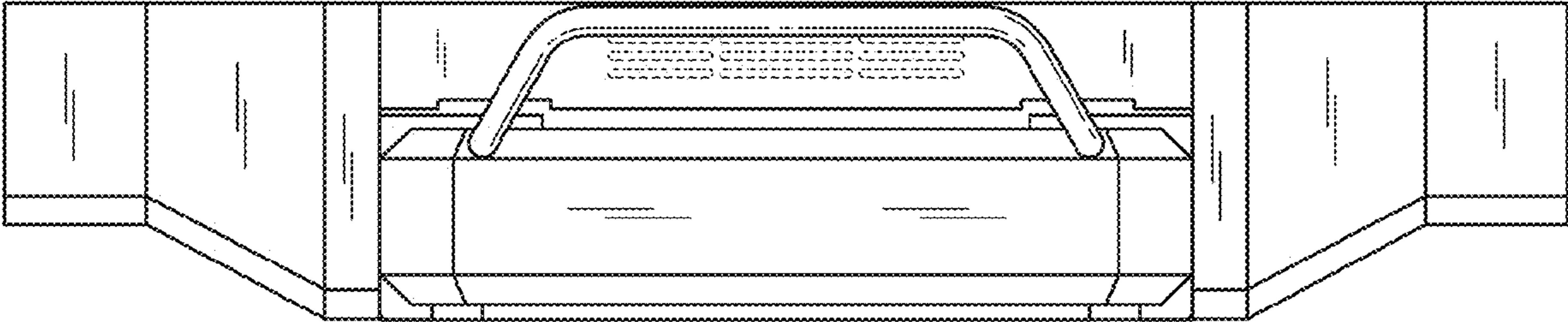

FIG. 1

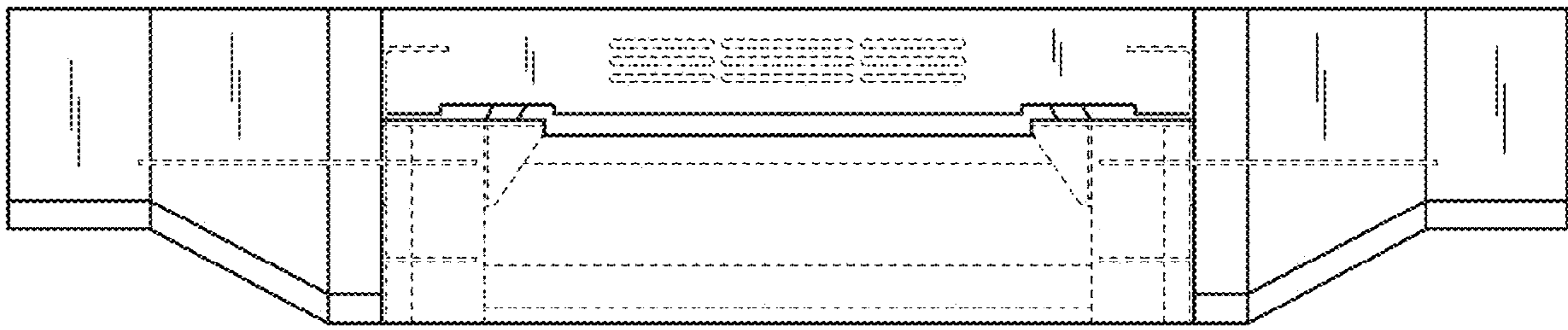

FIG. 2

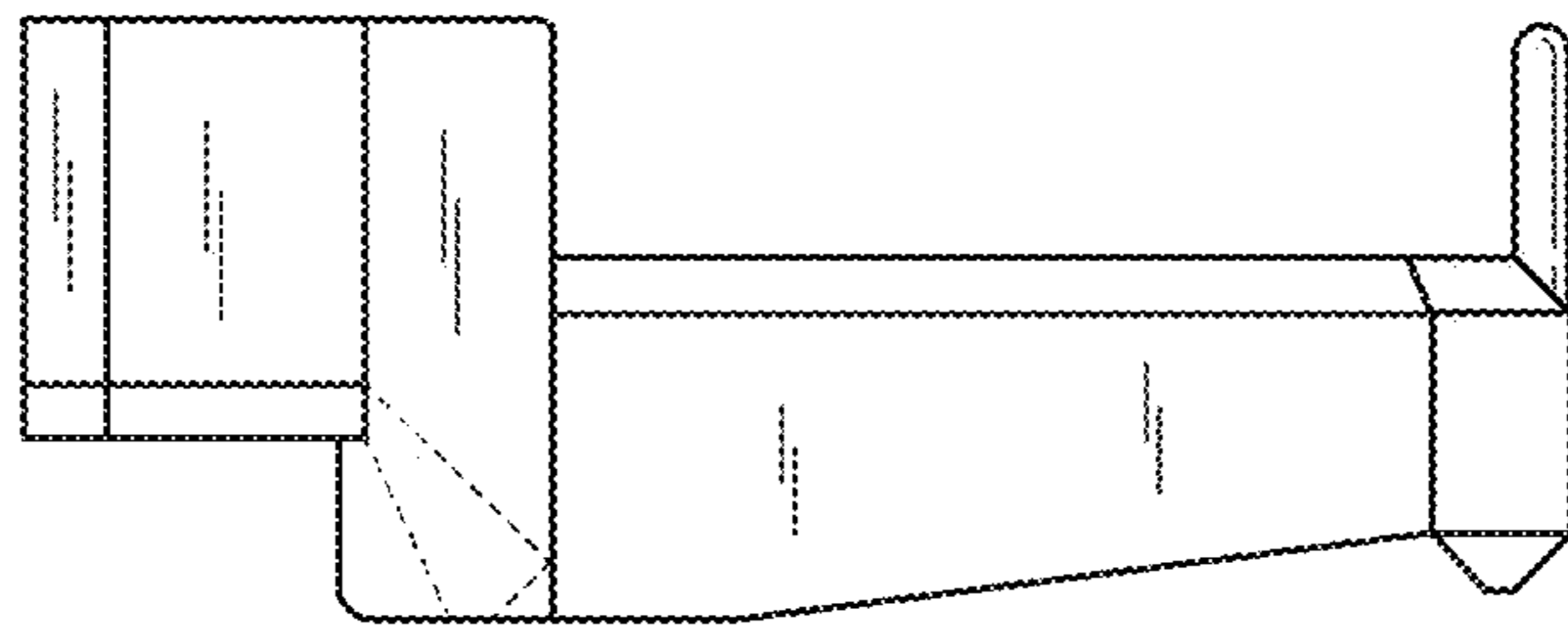

FIG. 3

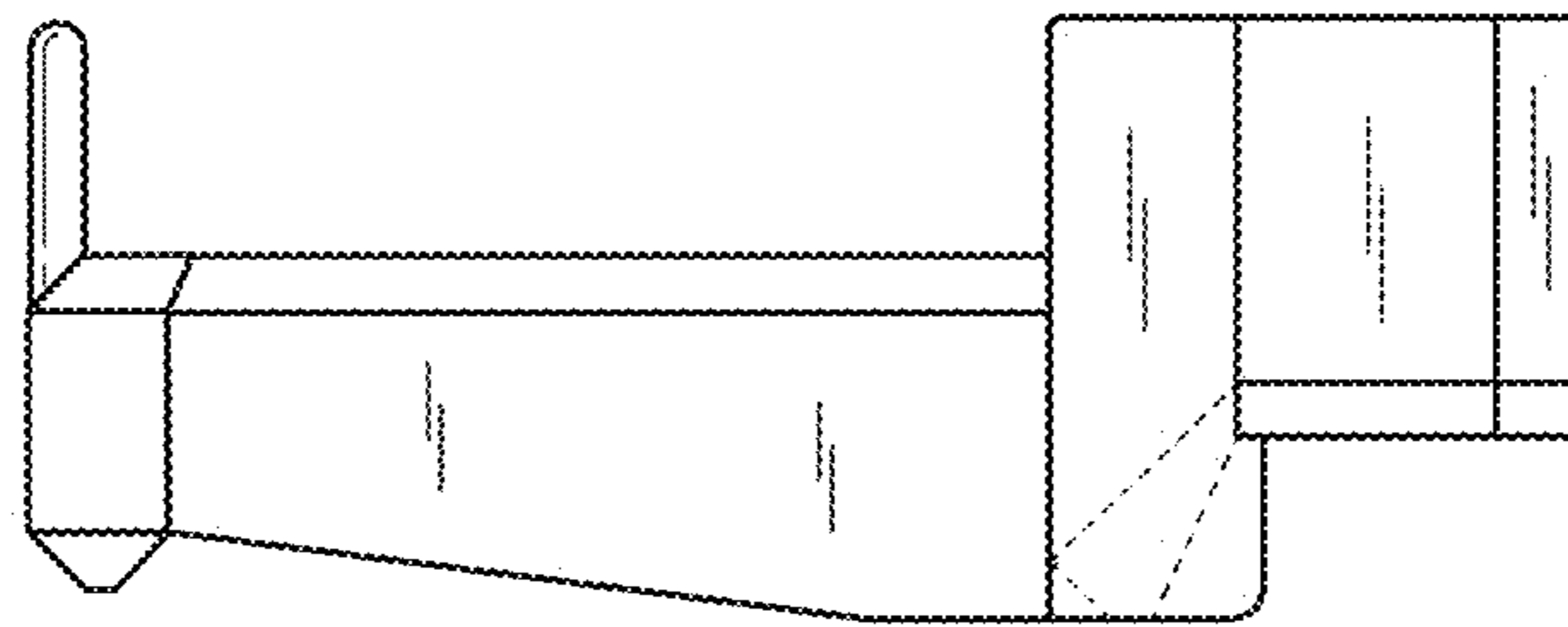

FIG. 4

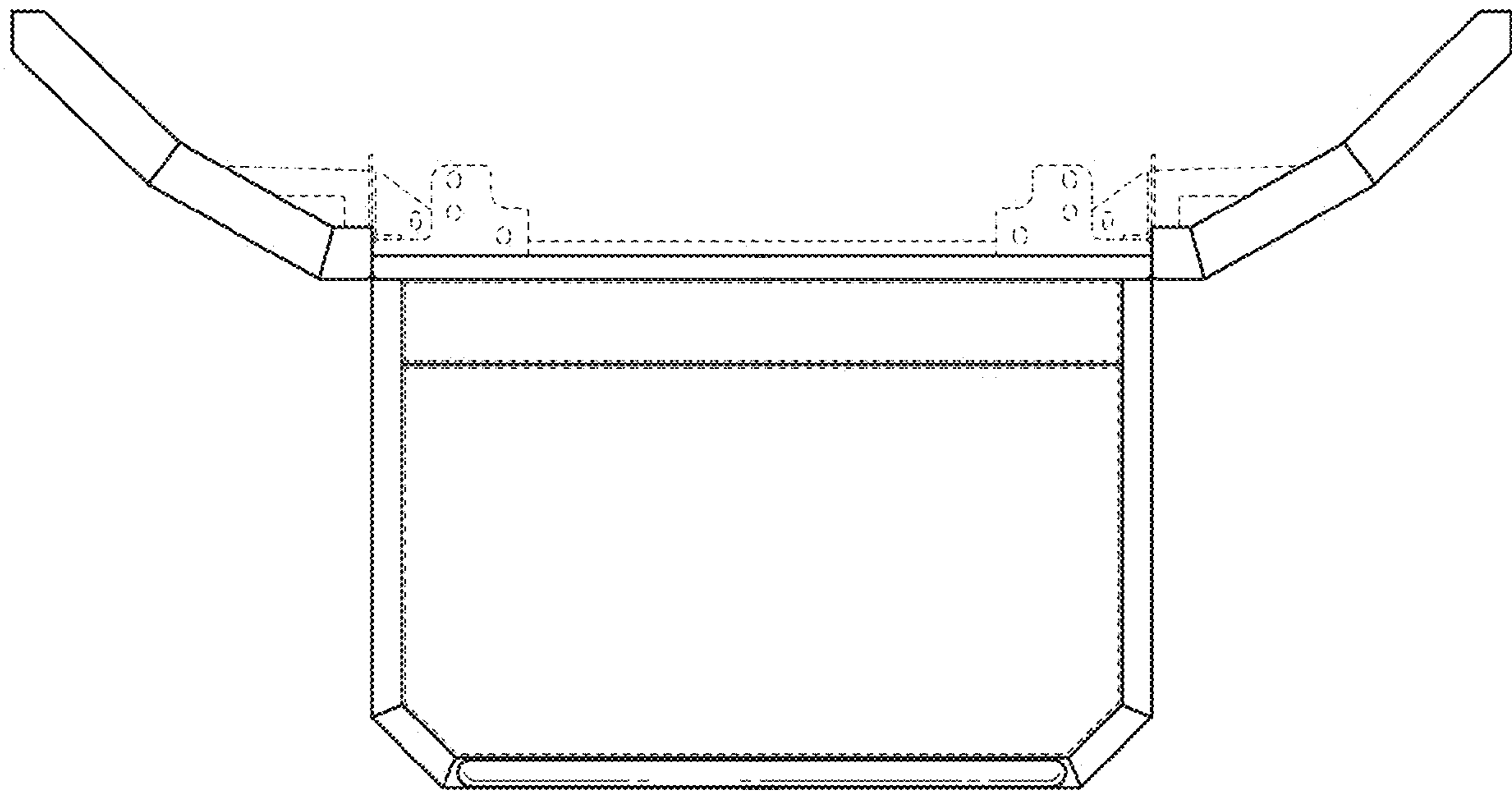

FIG. 5

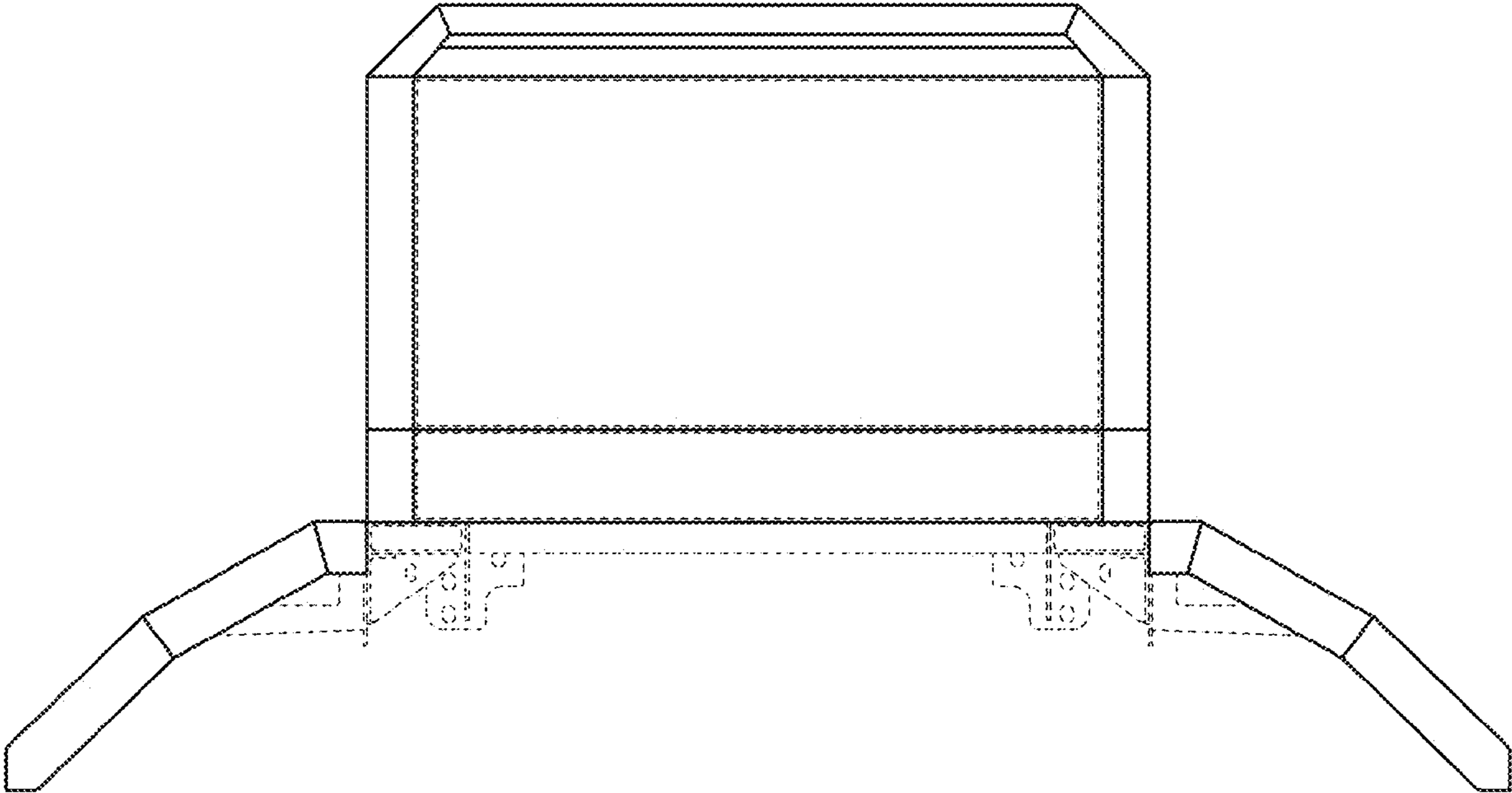

FIG. 6

UNITED STATES PATENT AND TRADEMARK OFFICE
CERTIFICATE OF CORRECTION

PATENT NO. : D948,317 S
APPLICATION NO. : 29/687216
DATED : April 12, 2022
INVENTOR(S) : Wruck et al.

Page 1 of 1

It is certified that error appears in the above-identified patent and that said Letters Patent is hereby corrected as shown below:

On the Title Page

In the Description

FIG. 5, after “top” and before “view” delete “plan”.

Signed and Sealed this
Fourteenth Day of June, 2022

Katherine Kelly Vidal
Director of the United States Patent and Trademark Office