



US00D948156S

(12) **United States Design Patent**
Furuuchi

(10) **Patent No.:** **US D948,156 S**

(45) **Date of Patent:** **** Apr. 5, 2022**

- (54) **ROLLER BALL FOR CONVEYANCE**
- (71) Applicant: **FREEBEAR CORPORATION**, Osaka (JP)
- (72) Inventor: **Hiroyuki Furuuchi**, Osaka (JP)
- (73) Assignee: **FREEBEAR CORPORATION**, Osaka (JP)

- 5,033,601 A * 7/1991 Huber B65G 39/025
193/35 MD
- 5,412,838 A * 5/1995 Yang B60B 33/08
16/26
- 5,464,086 A * 11/1995 Coelln B65G 39/025
193/35 B

(Continued)

- (**) Term: **15 Years**
- (21) Appl. No.: **29/729,184**
- (22) Filed: **Mar. 24, 2020**

(30) **Foreign Application Priority Data**

Sep. 26, 2019 (JP) 2019-021509

- (51) **LOC (13) Cl.** **12-05**
- (52) **U.S. Cl.**
USPC **D34/29; D8/375**
- (58) **Field of Classification Search**
USPC D8/315, 321-322, 373-375; D15/138,
D15/143; D34/28-29
CPC B60B 33/08; B65G 39/025; F16C 29/046;
Y10T 16/1889
See application file for complete search history.

(56) **References Cited**

U.S. PATENT DOCUMENTS

- 2,690,584 A * 10/1954 Freddolino B60B 33/08
16/26
- 2,779,965 A * 2/1957 Schilberg B60B 33/08
16/26
- 3,381,330 A * 5/1968 Aninger B60B 33/08
16/21
- 3,577,620 A * 5/1971 Hoffman B60B 33/08
29/898.062
- D291,059 S * 7/1987 Mickelson D8/375
- 4,871,052 A * 10/1989 Huber B60B 33/08
193/35 MD

OTHER PUBLICATIONS

“Omnitrack Service Kits for Ball Transfer Units”, Nov. 21, 2014, YouTube.com, site visited Nov. 8, 2021: https://www.youtube.com/watch?v=VrG0_ktmKHE (Year: 2014).*

(Continued)

Primary Examiner — Jack Reickel

Assistant Examiner — Michael A Kervin

(74) *Attorney, Agent, or Firm* — Fitch, Even, Tabin & Flannery LLP

(57) **CLAIM**

I claim the ornamental design for a roller ball for conveyance, as shown and described.

DESCRIPTION

FIG. 1 is a front, right, top perspective view of a roller ball for conveyance, showing my new design;
 FIG. 2 is a front elevational view thereof, the rear elevational view being the same;
 FIG. 3 is a top plan view thereof;
 FIG. 4 is a bottom plan view thereof;
 FIG. 5 is a right side elevational view thereof, the left side elevational view being the same; and,
 FIG. 6 is an enlarged cross-sectional view taken along line 6-6 in FIG. 3.
 The dashed broken lines show portions of the roller ball for conveyance that form no part of the claimed design. The dot-dash broken lines define the bounds of the claimed design and form no part thereof.

1 Claim, 3 Drawing Sheets

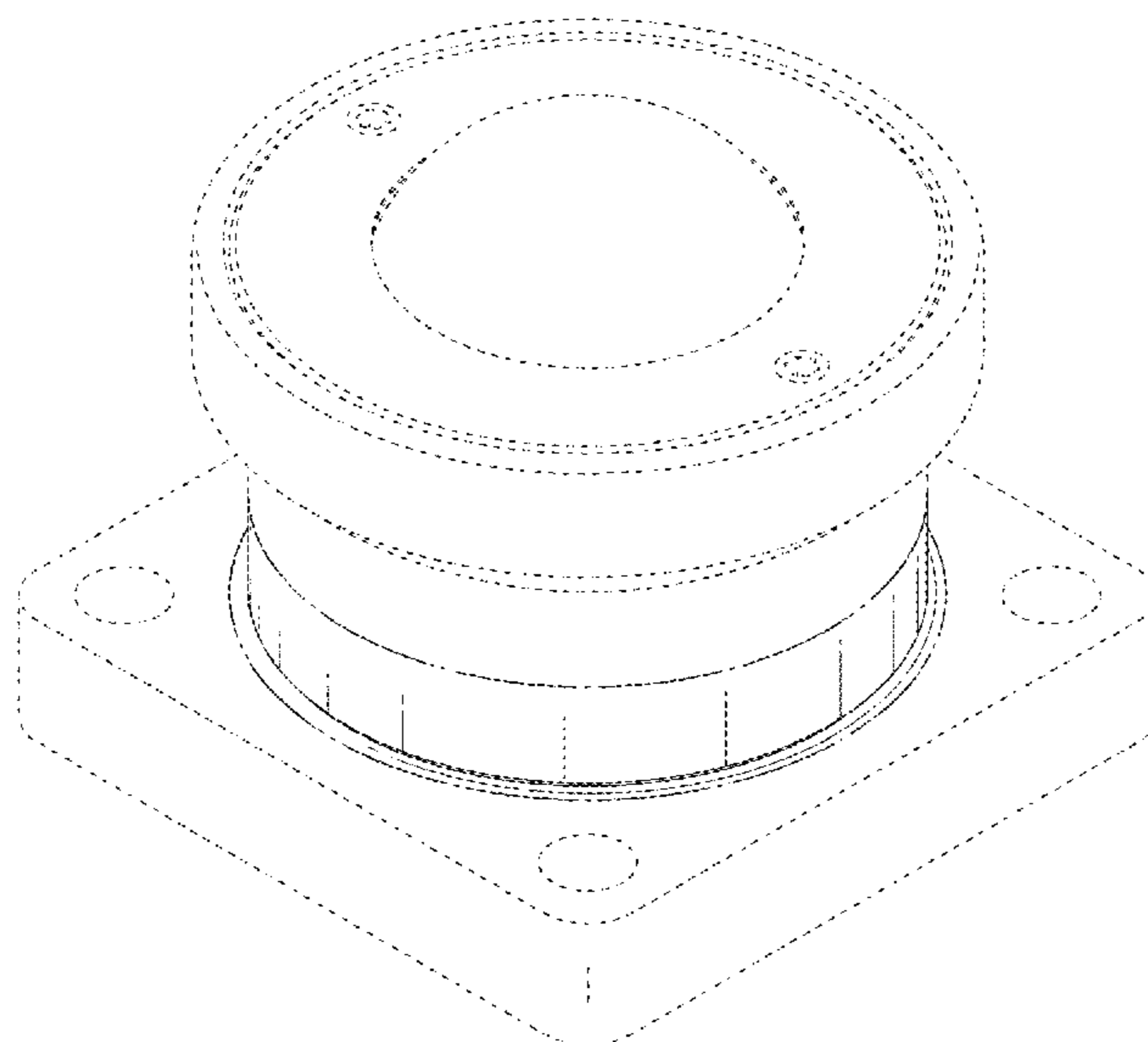

(56)

References Cited

U.S. PATENT DOCUMENTS

5,533,604 A * 7/1996 Brierton B65G 39/025
193/35 MD
5,538,346 A * 7/1996 Frias B65G 39/025
193/35 MD
5,540,314 A * 7/1996 Coelln B65G 39/025
193/35 MD
D376,461 S * 12/1996 Graf D34/28
D392,875 S * 3/1998 Scott D8/375
D407,629 S * 4/1999 Ezan D8/375
D661,980 S * 6/2012 Rocquet D8/374
D679,579 S * 4/2013 Rocquet D8/374
D685,255 S * 7/2013 Rocquet D8/374
D878,701 S * 3/2020 Specht D34/29
D914,319 S * 3/2021 Specht D34/29
D914,320 S * 3/2021 Specht D34/29
2008/0271972 A1 * 11/2008 Szarkowski B65G 39/025
193/35 MD
2020/0031586 A1 * 1/2020 Miess B65G 39/025

OTHER PUBLICATIONS

“Ball Transfer Unit Conveyor Bearing”, Apr. 11, 2016, YouTube.com, site visited Nov. 8, 2021: <https://bearingsite.wordpress.com/2016/04/11/ball-transfer-unit-conveyor-bearing-professional-supplier-in-china/> (Year: 2016).*

* cited by examiner

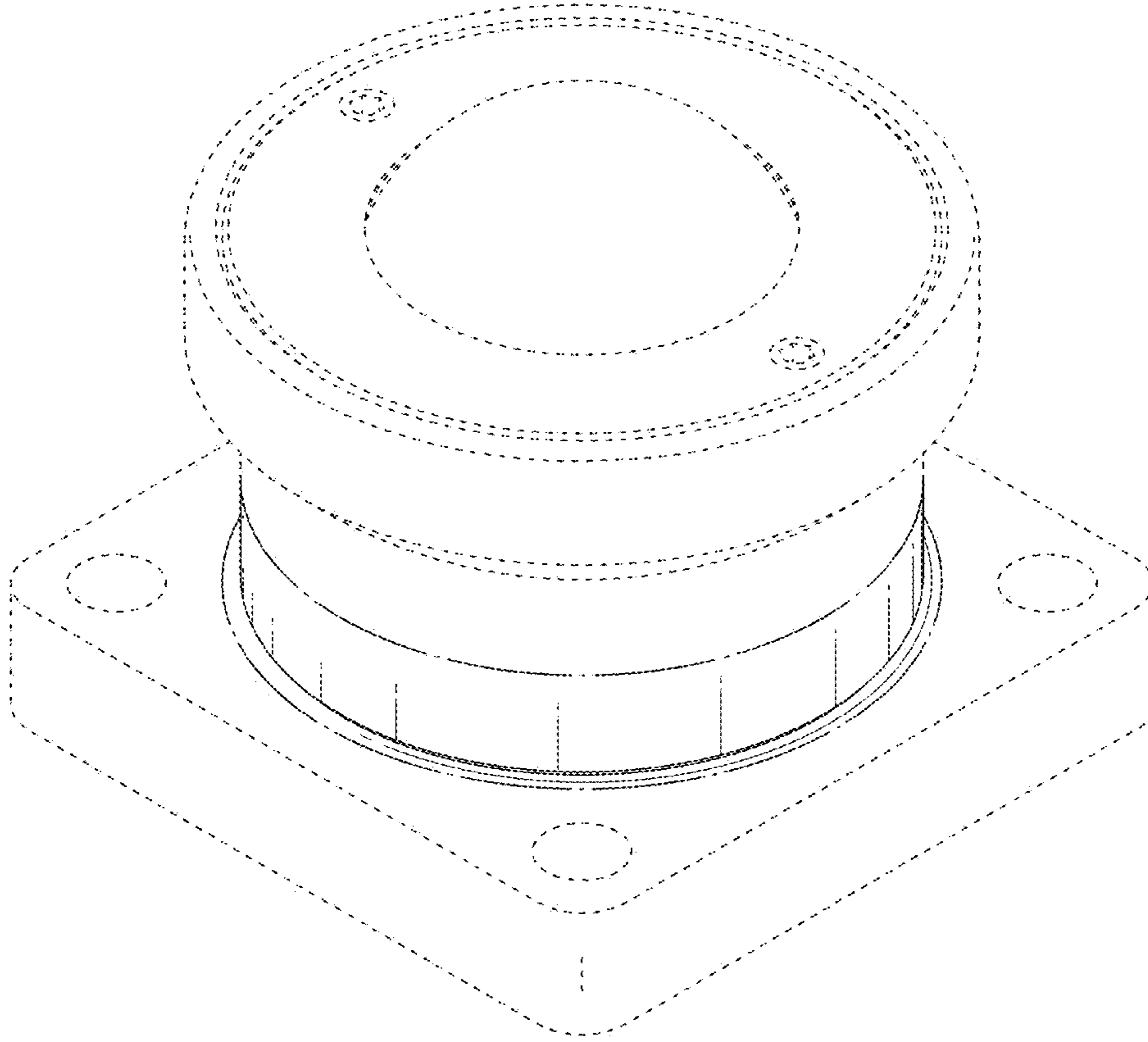

FIG. 1

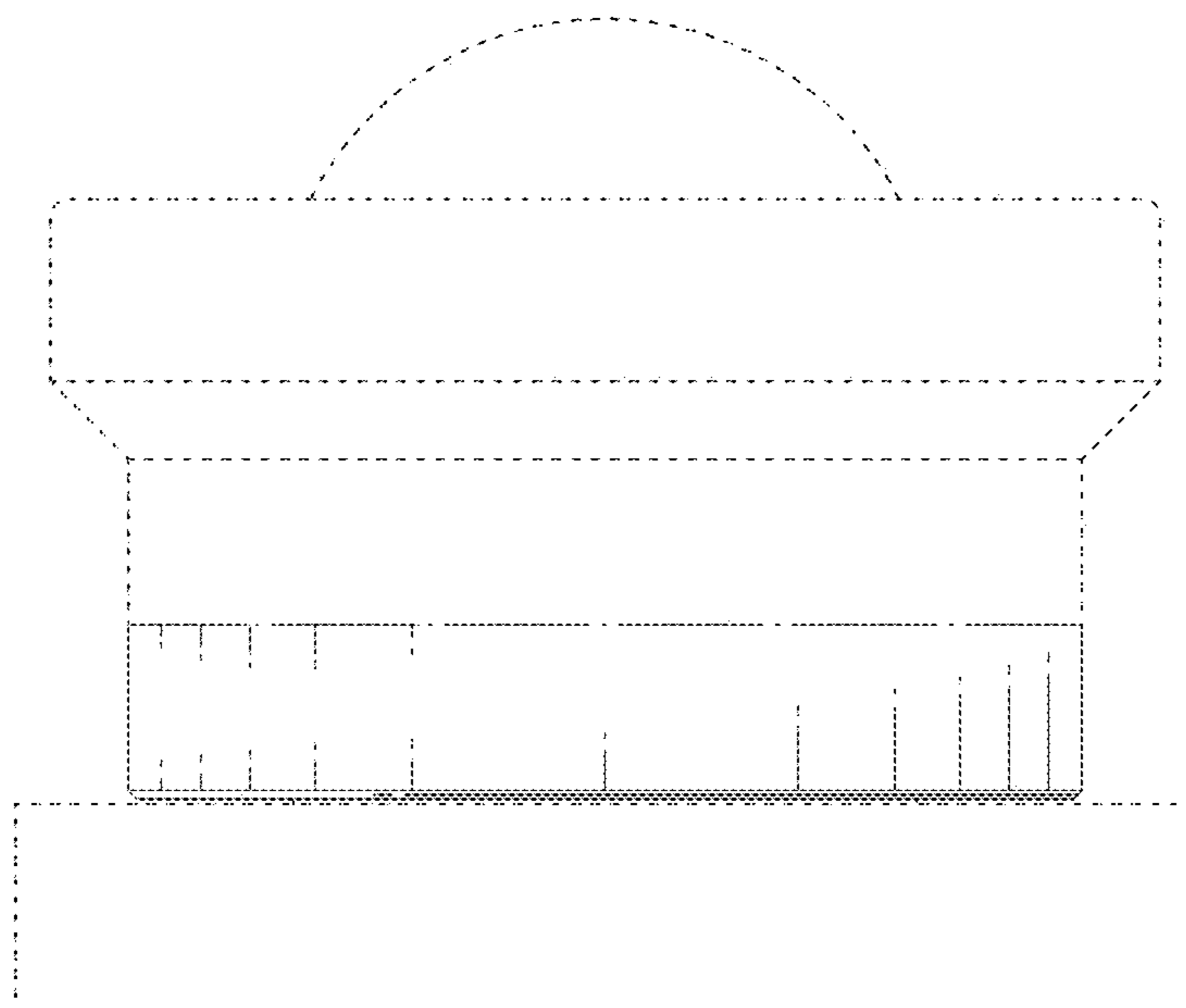

FIG. 2

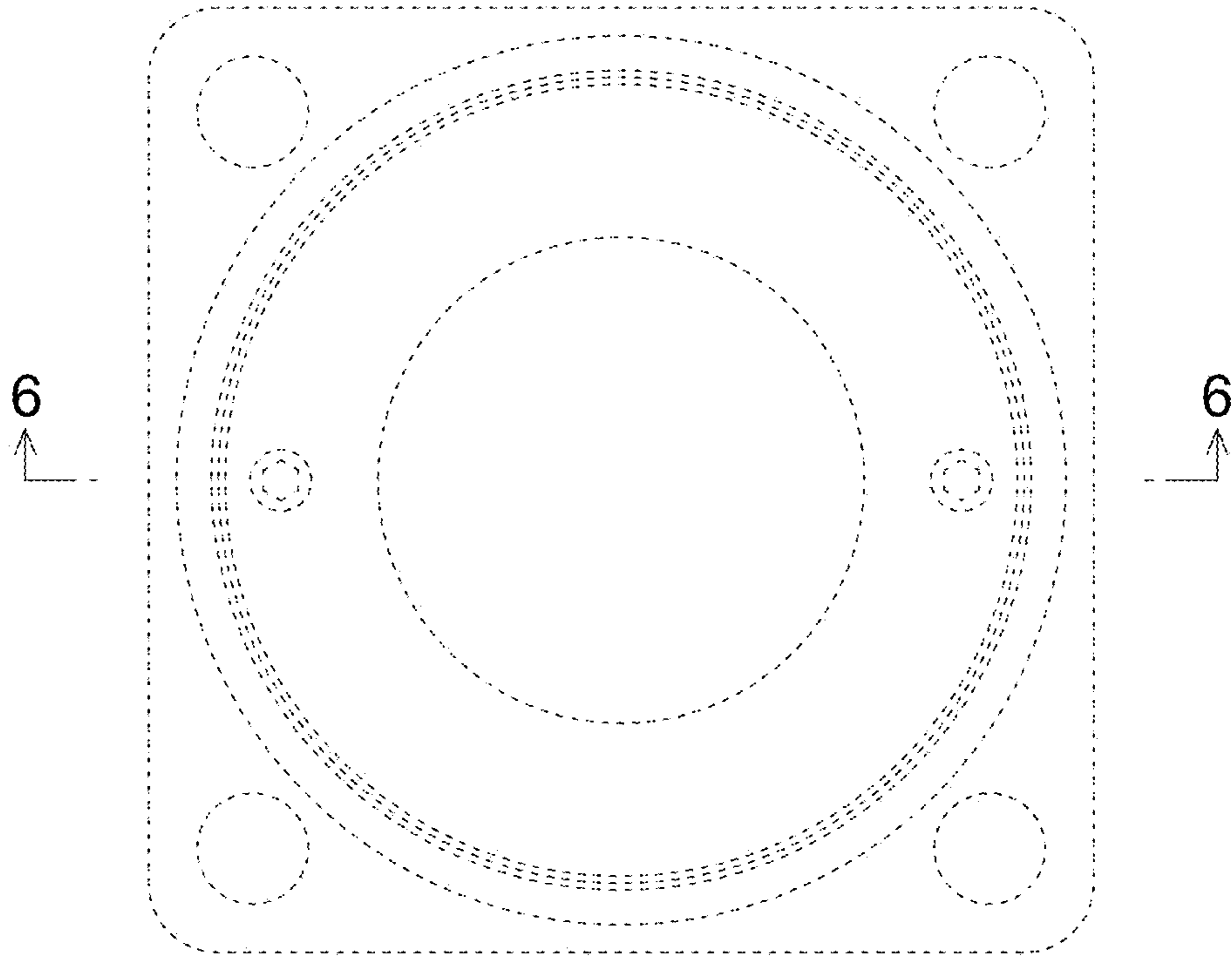

FIG. 3

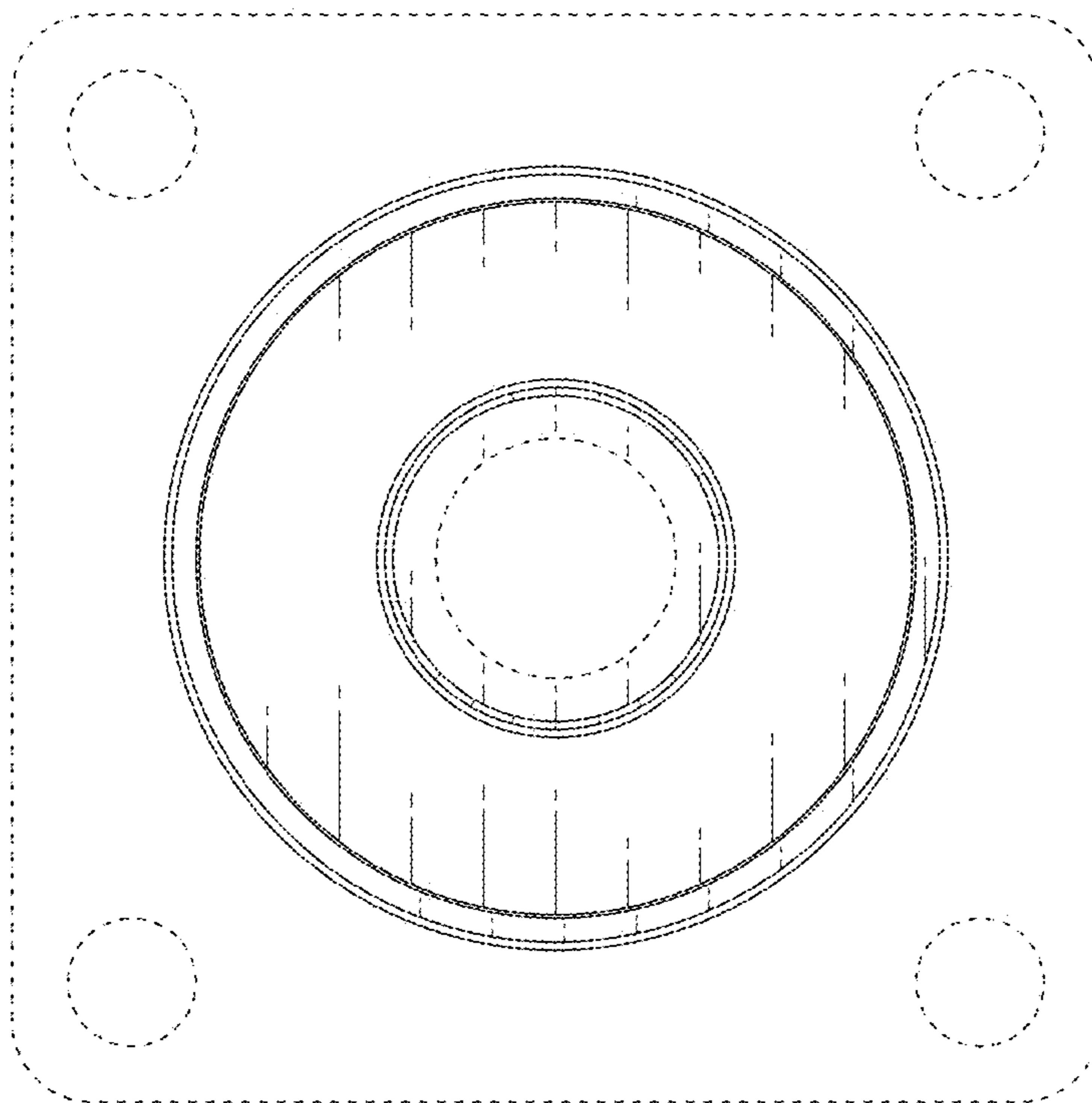

FIG. 4

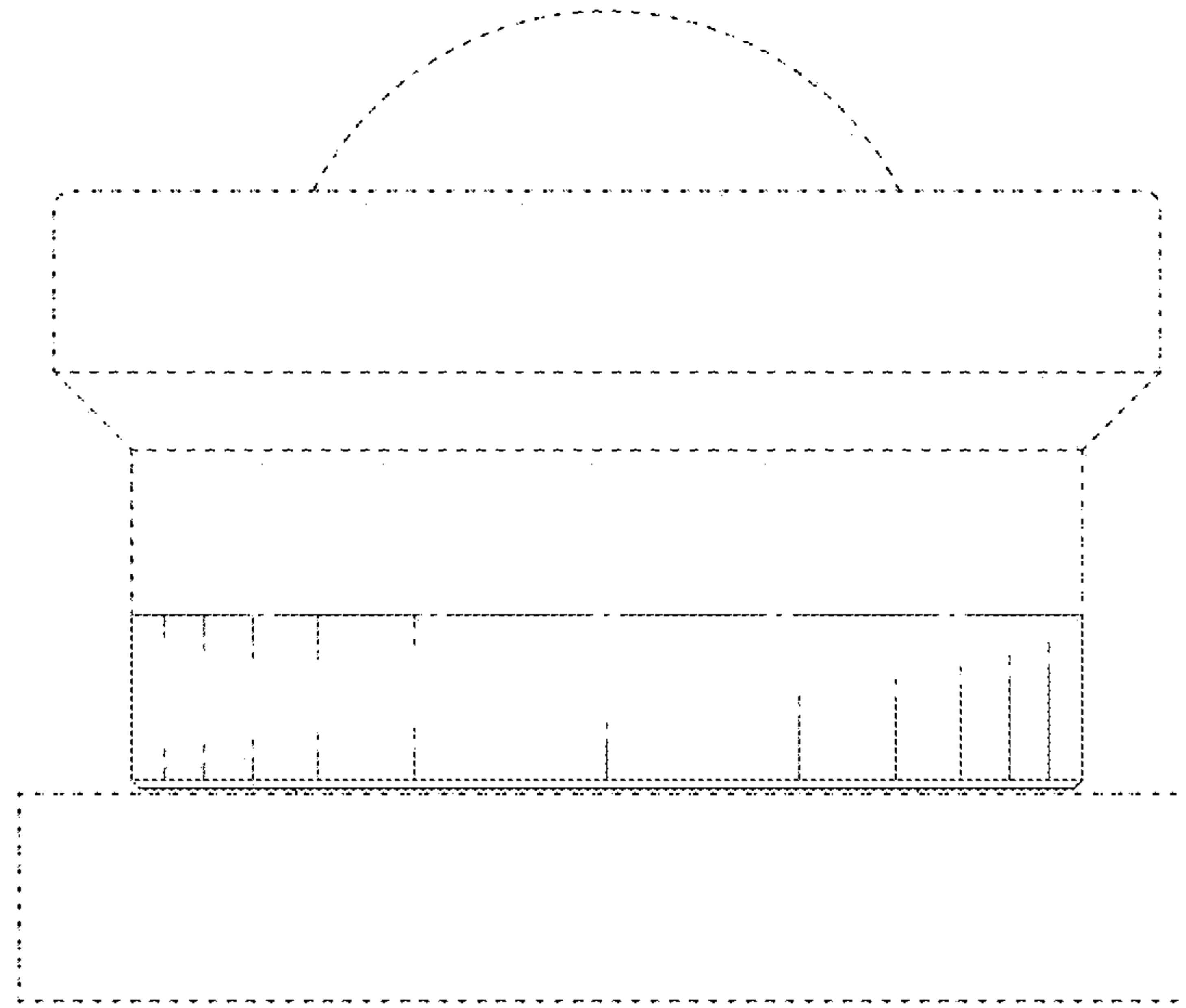

FIG. 5

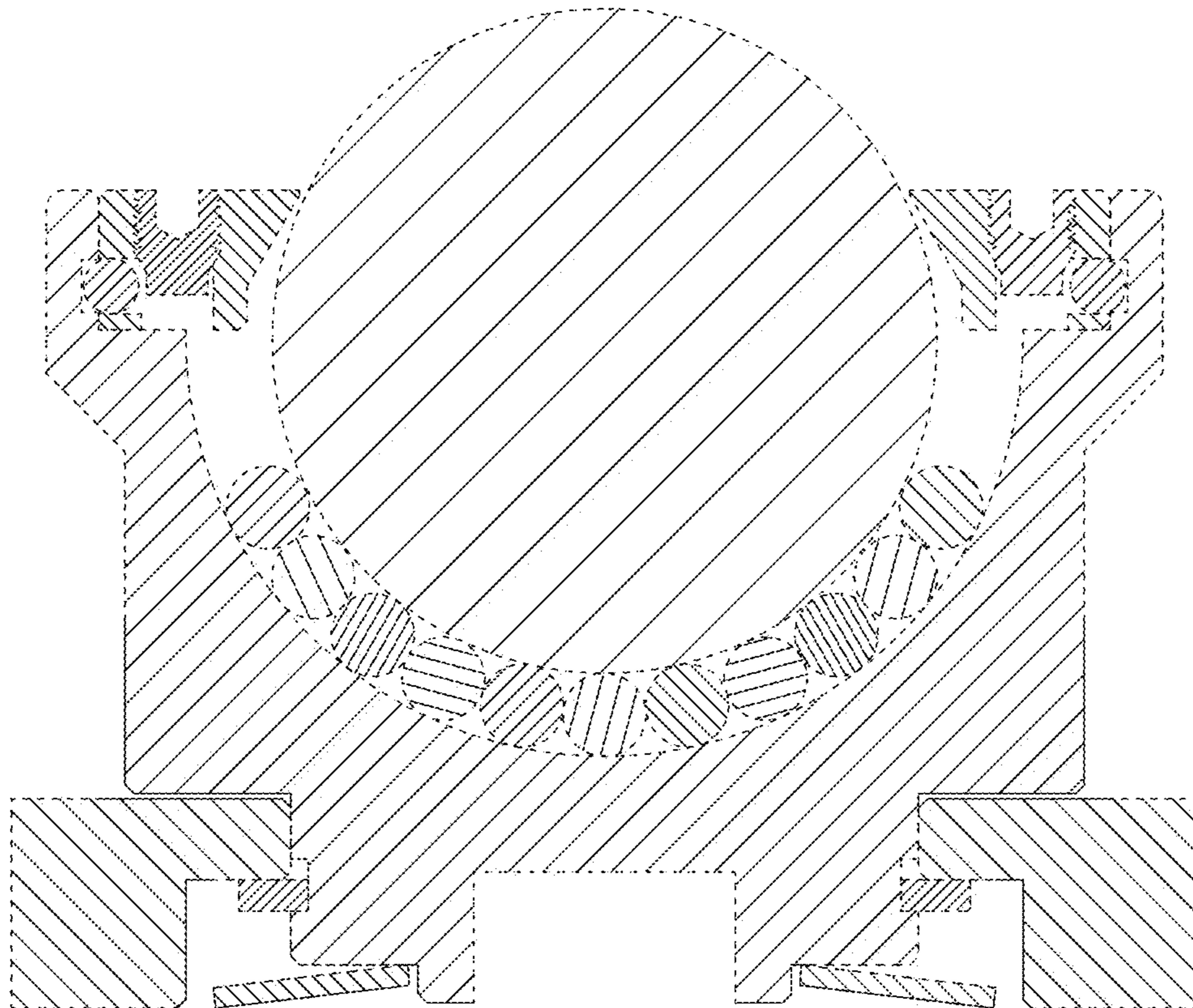

FIG. 6