

US00D947956S

(12) **United States Design Patent** (10) **Patent No.:** **US D947,956 S**
Barajas et al. (45) **Date of Patent:** **** *Apr. 5, 2022**

(54) **MODEL VEHICLE BODY**

(71) Applicant: **TRAXXAS, L.P.**, McKinney, TX (US)

(72) Inventors: **Jaime Felix Barajas**, Dallas, TX (US); **Kent Poteet**, Lucas, TX (US); **Otto Karl Allmendinger**, Rowlett, TX (US)

(73) Assignee: **TRAXXAS, L.P.**, McKinney, TX (US)

(*) Notice: This patent is subject to a terminal disclaimer.

(**) Term: **15 Years**

(21) Appl. No.: **29/776,902**

(22) Filed: **Apr. 1, 2021**

(51) **LOC (13) Cl.** **21-01**

(52) **U.S. Cl.**
USPC **D21/552**; D21/562; D12/98

(58) **Field of Classification Search**
USPC D21/433, 552, 562, 548; D12/86, 89, 90, D12/91, 92, 93, 98
CPC B62D 35/00; B62D 35/007; B62D 37/02; B62D 23/00; B62D 33/00; B62D 31/00; B62D 21/00; B62D 29/00; Y02T 10/82
See application file for complete search history.

(56) **References Cited**

U.S. PATENT DOCUMENTS

- D190,991 S * 8/1961 Ornas, Jr. B60J 7/1621 D12/98
- 3,068,038 A * 12/1962 Douglass, Jr. B62D 33/08 296/37.6
- 3,146,824 A * 9/1964 Veilleux B60J 7/085 160/23.1
- 3,201,171 A * 8/1965 Wickard B60J 7/062 296/100.15
- 3,704,039 A * 11/1972 Dean B60J 7/1621 296/100.07
- D252,200 S * 6/1979 Brinker 296/107.09

(Continued)

FOREIGN PATENT DOCUMENTS

CA 56782 * 8/1986 B60G 7/001
CN 304894048 * 11/2018

(Continued)

OTHER PUBLICATIONS

“1967 Chevy C10 Show Truck Slammed on Coils K5 Blazer Bronco Bagged Slammed,” 1967, topclassiccarsforsale.com, site visited Dec. 20, 2021, URL: <https://topclassiccarsforsale.com/chevrolet/569932-1967-chevy-c10-show-truck-slammed-on-coils-k5-blazer-bronco-bagged-slammed.html> (Year: 1967).*

(Continued)

Primary Examiner — Eric L Goodman

Assistant Examiner — Sarah L Smith

(74) *Attorney, Agent, or Firm* — Daryl R. Wright; Greg Carr

(57) **CLAIM**

We claim the ornamental design for a model vehicle body, as shown and described.

DESCRIPTION

FIG. 1 is an upper, left, front perspective view of a model vehicle body showing our new design; FIG. 2 is a front elevation view thereof; FIG. 3 is a rear elevation view thereof; FIG. 4 is a left side elevation view thereof; FIG. 5 is a right side elevation view thereof; FIG. 6 is an upper plan view thereof; FIG. 7 is a lower plan view thereof; and, FIG. 8 is an upper, left, rear perspective view of the model vehicle body.

In the drawings, the broken lines illustrate portions of the model vehicle body that form no part of the claimed design.

1 Claim, 6 Drawing Sheets

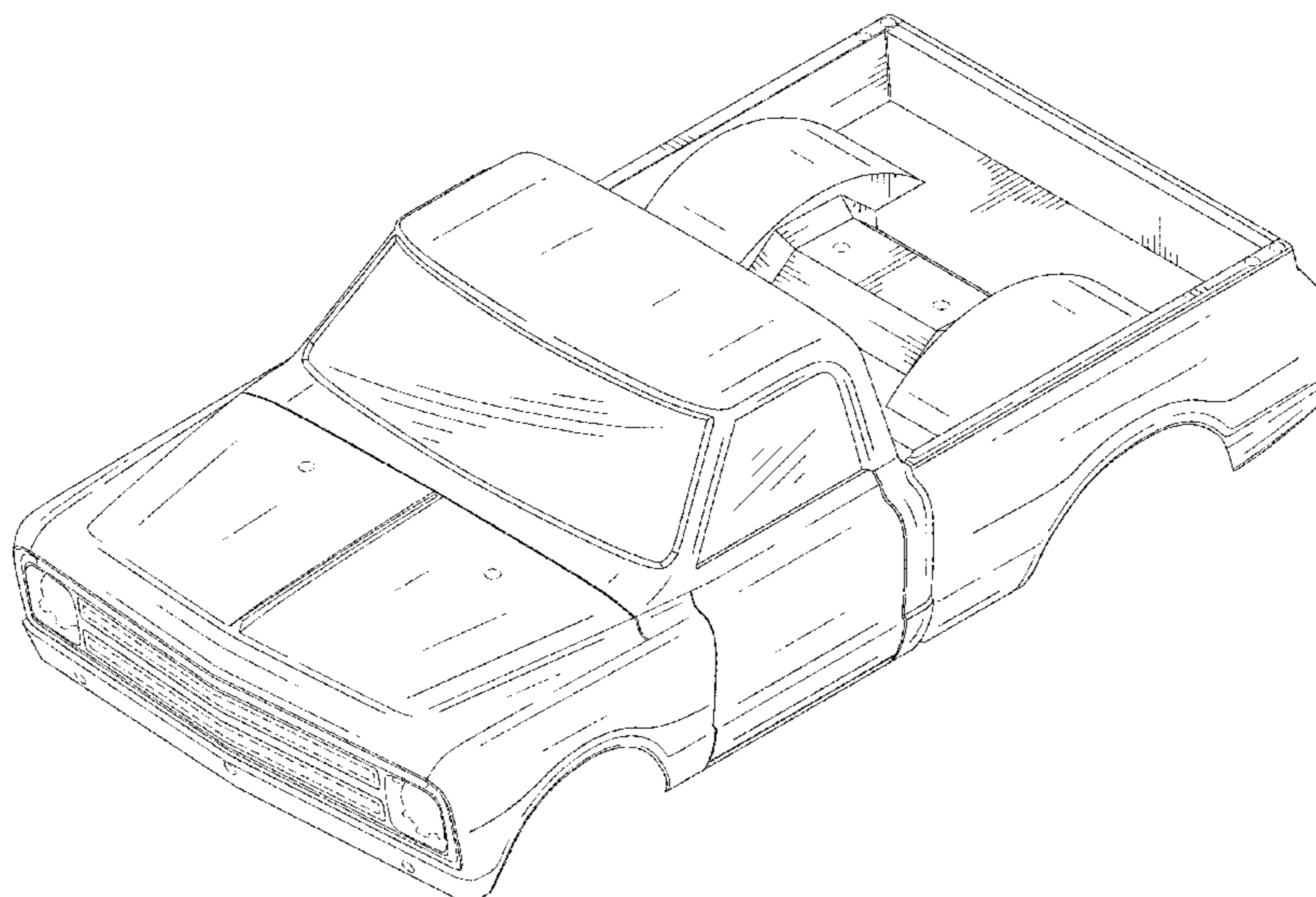

(56)

References Cited

U.S. PATENT DOCUMENTS

4,188,058 A * 2/1980 Resa B60R 13/01
296/208
D256,901 S * 9/1980 Carr, Jr. B60R 9/02
D12/14
4,506,870 A * 3/1985 Penn B62D 33/0273
296/180.1
D281,000 S * 10/1985 Kuna B60R 13/01
D21/559
D300,522 S * 4/1989 Wegner D12/98
D312,806 S * 12/1990 Page D12/98
D313,379 S * 1/1991 Machida D12/98
5,615,922 A * 4/1997 Blanchard B60R 9/02
224/404
6,520,564 B1 2/2003 Liang
D496,409 S 9/2004 Tilbor
D603,295 S 11/2009 Honeycutt et al.
D790,402 S 6/2017 Perini
D879,209 S 3/2020 Ewing
D879,212 S * 3/2020 Barajas B60J 7/062
D21/562
10,661,843 B1 * 5/2020 Nieves B62D 33/0276
2009/0195016 A1 8/2009 Schwan et al.

2013/0221701 A1 8/2013 De Luca
2019/0256157 A1 8/2019 Hinterbuchinger
2020/0070903 A1 3/2020 Woelfle et al.

FOREIGN PATENT DOCUMENTS

KR 300908105.0000 * 5/2017
WO WO-2021046302 A1 * 3/2021 B60G 7/001

OTHER PUBLICATIONS

Tim Bernsau (photographer), Jorge Nunez (author), "Is This The Most Powerful 1967 Chevy C10?" May 27, 2017, motortrend.com, site visited Dec. 21, 2021, URL: <https://www.motortrend.com/features/powerful-1967-chevy-c10/> (Year: 2017).*
"TMI Products," Jul. 30, 2019, facebook.com, site visited Dec. 14, 2021, URL: <https://www.facebook.com/TMIproducts/photos/a.217425150700/10157919220855701/> (Year: 2019).*
"TMI Products," May 5, 2019 (1967 C10), facebook.com, site visited Dec. 14, 2021, URL: <https://www.facebook.com/TMIproducts/photos/a.217425150700/10157533970560701/> (Year: 2019).*
"Jconcepts," Aug. 31, 2019, instagram.com, site visited Dec. 20, 2021, URL: <https://www.instagram.com/p/B119ULnhy4C/> (Year: 2019).*

* cited by examiner

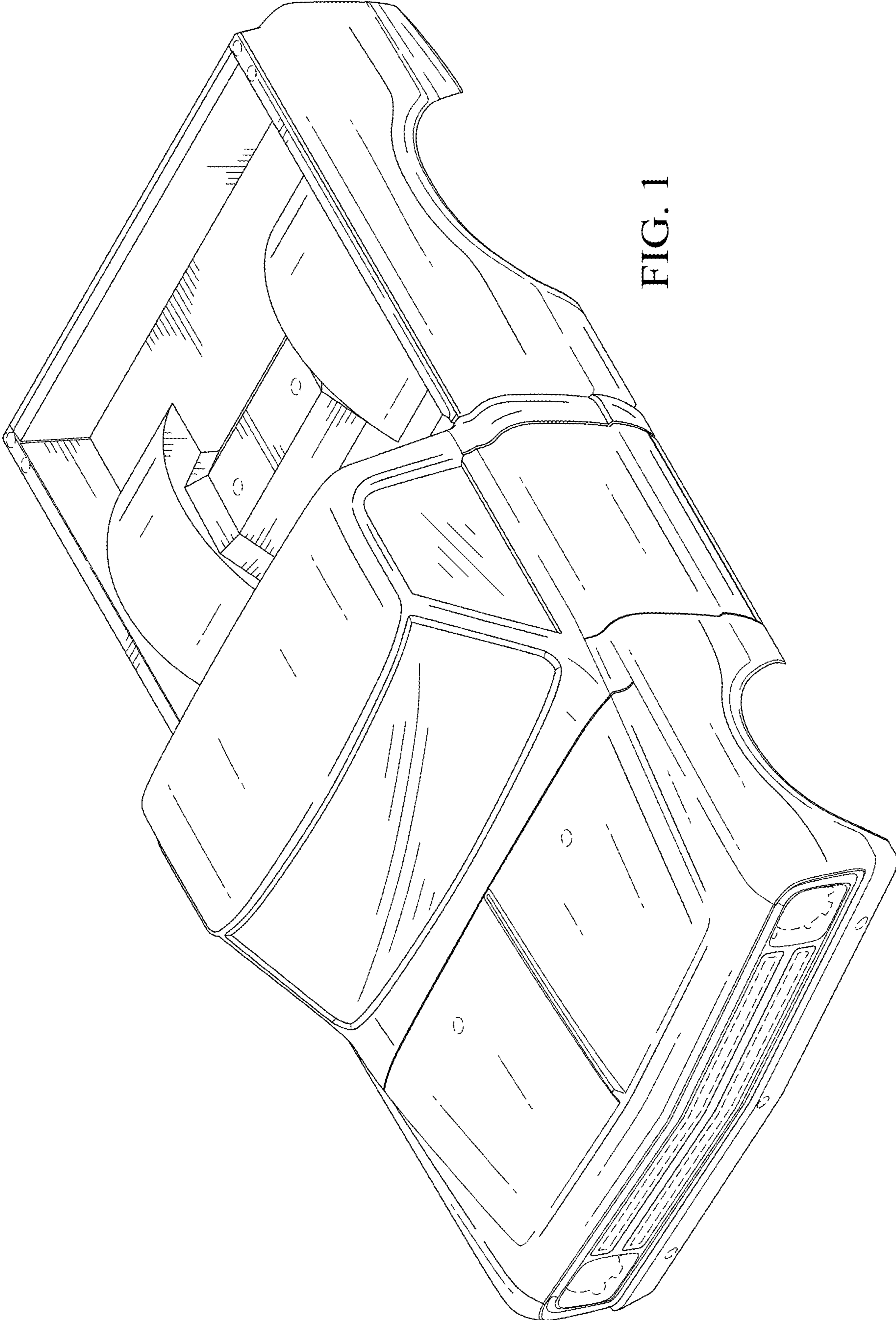

FIG. 1

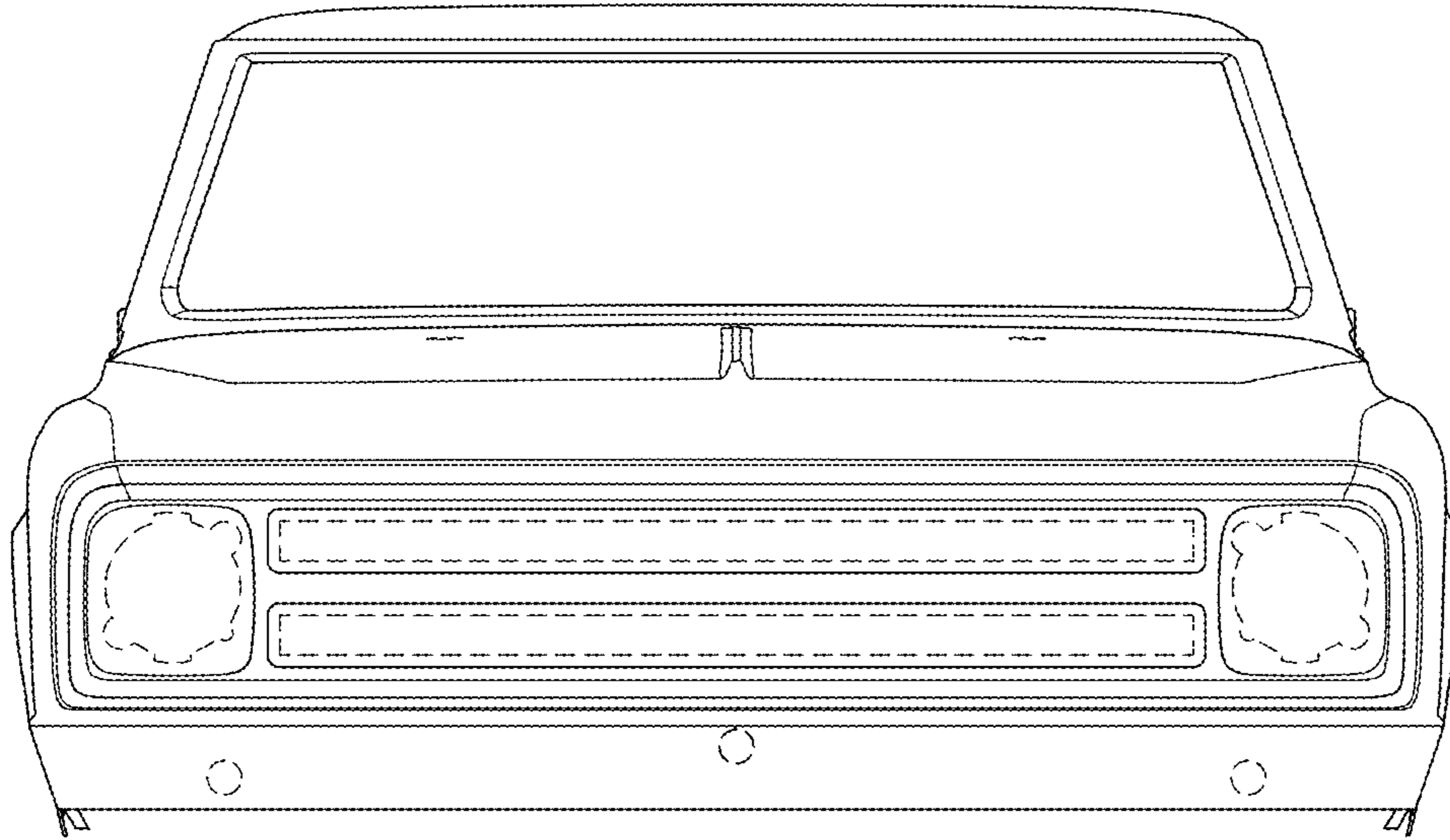

FIG. 2

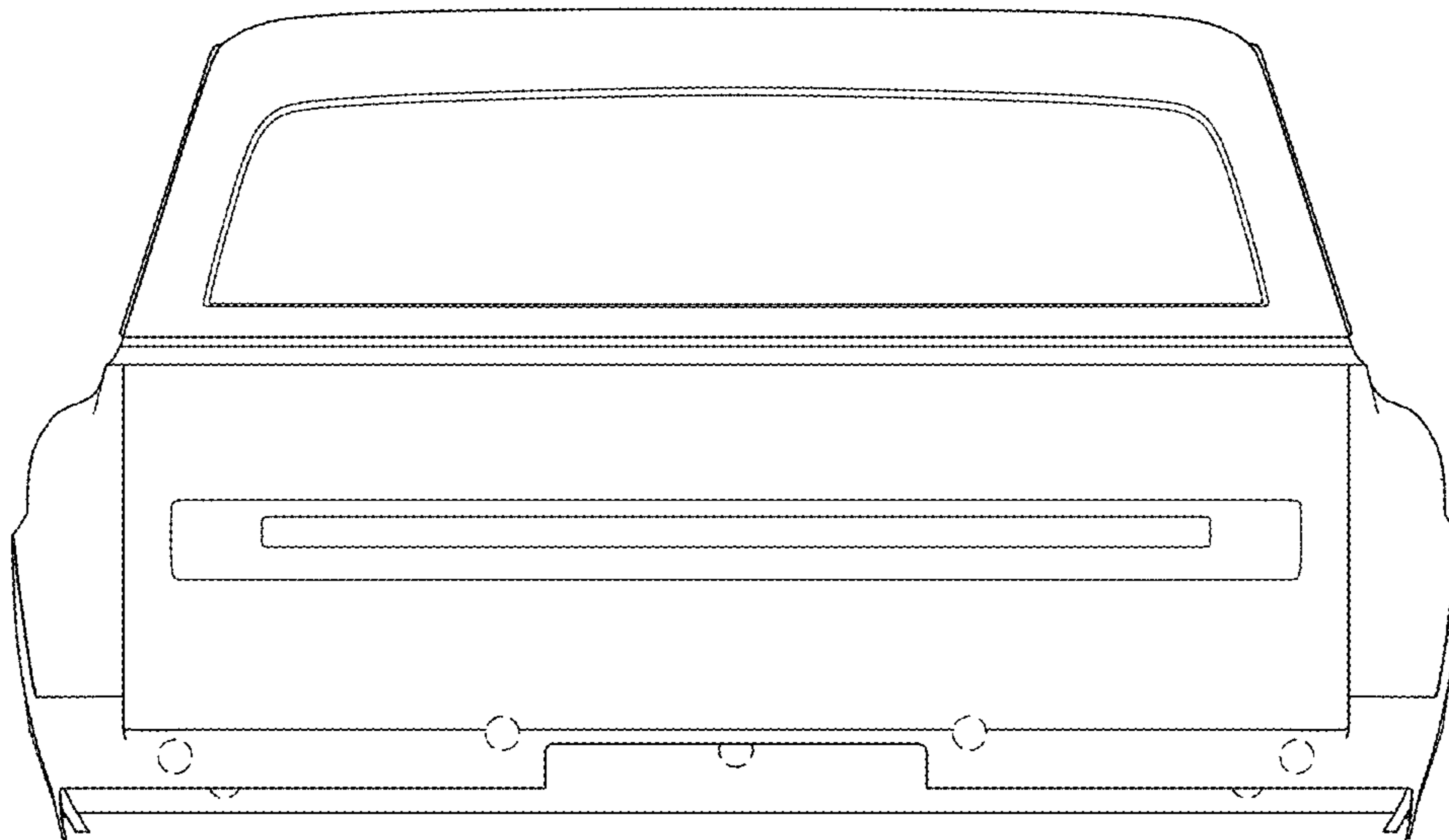

FIG. 3

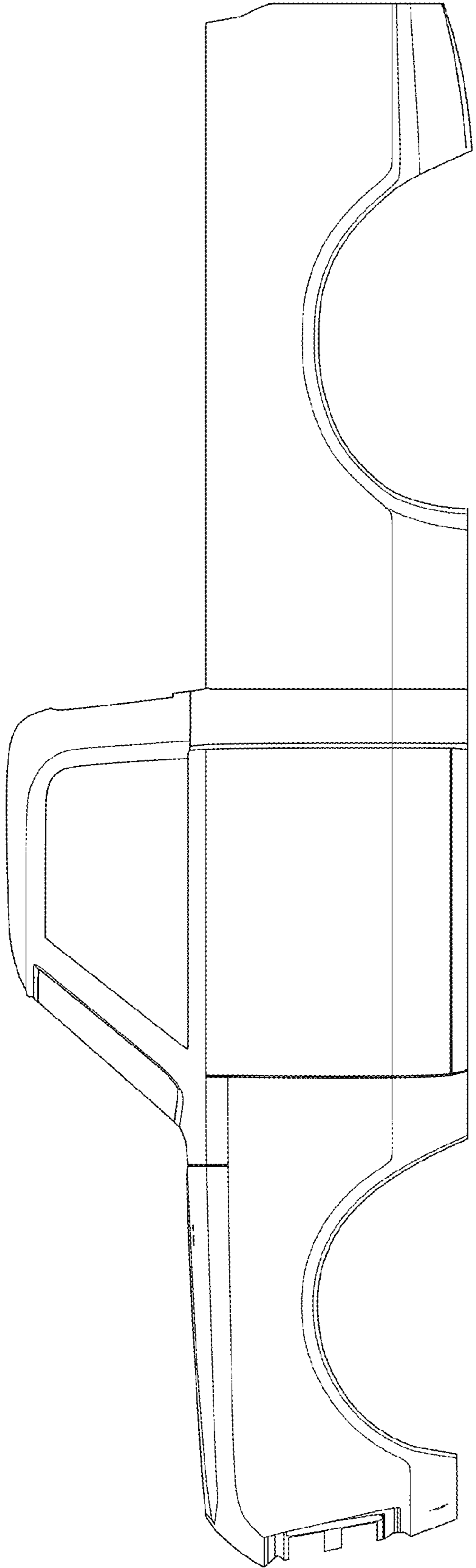

FIG. 4

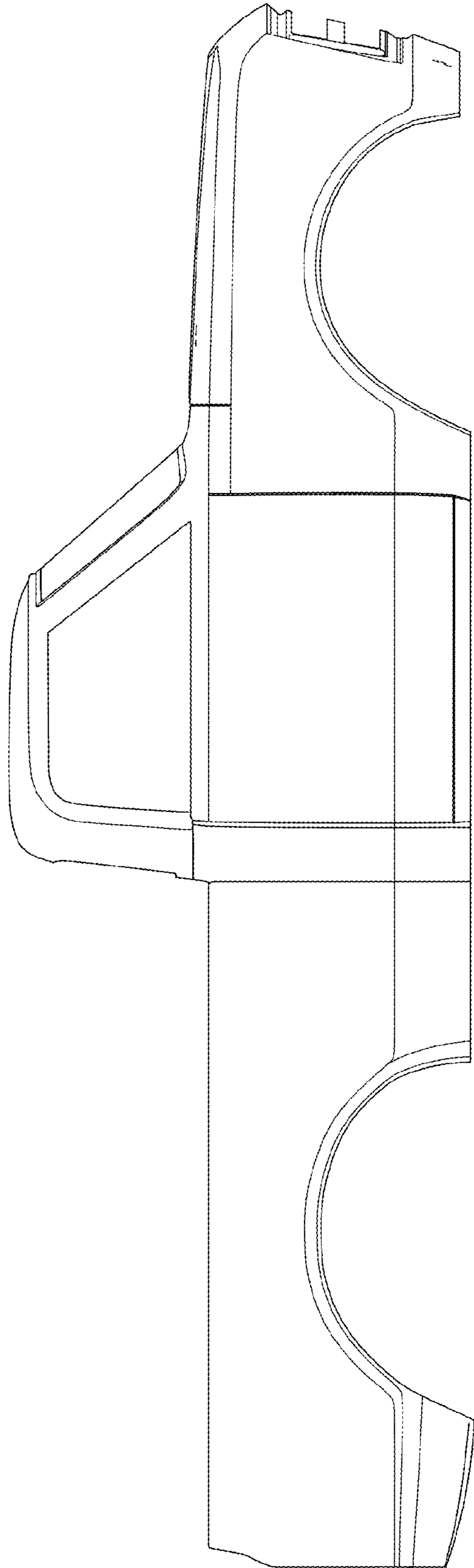

FIG. 5

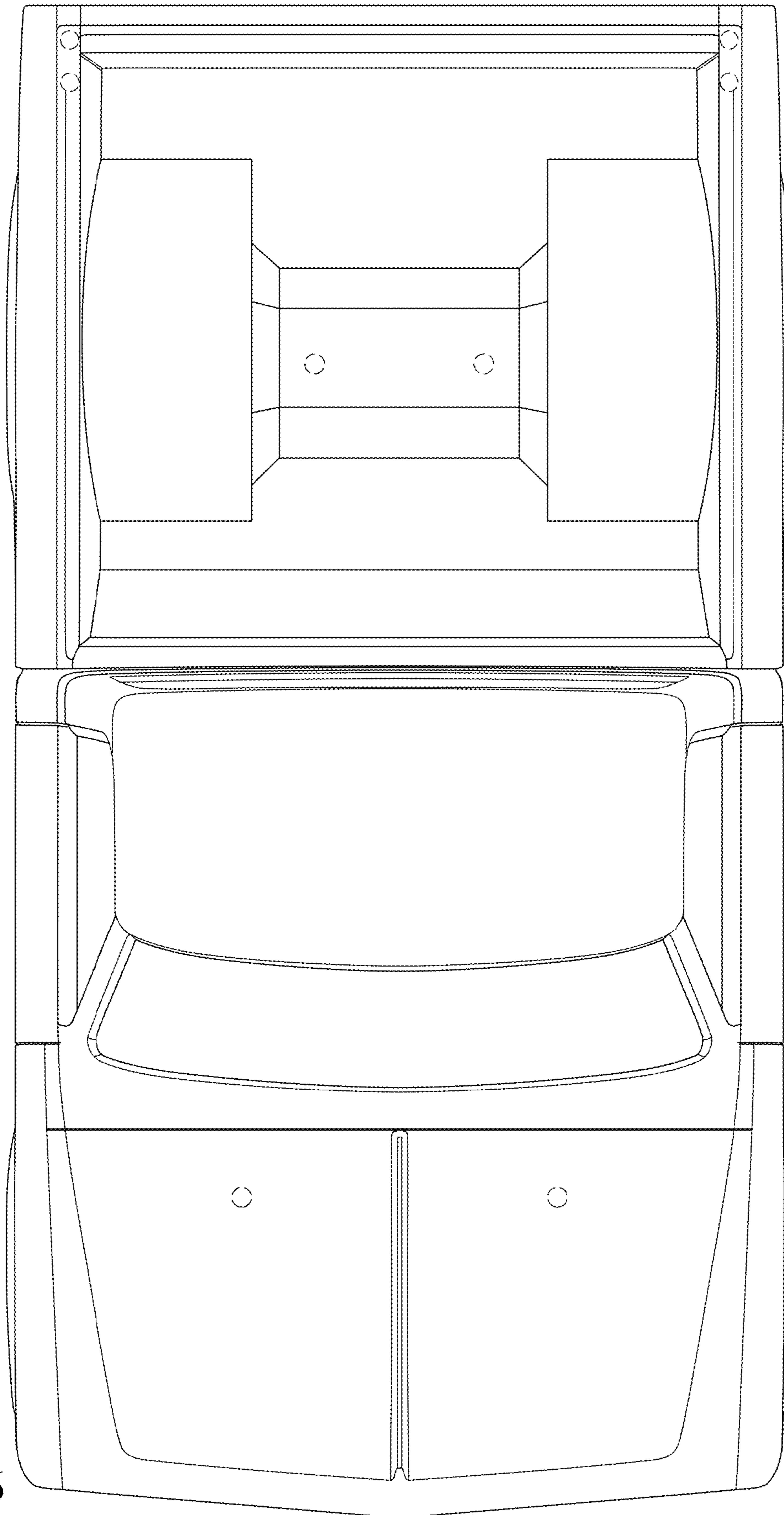

FIG. 6

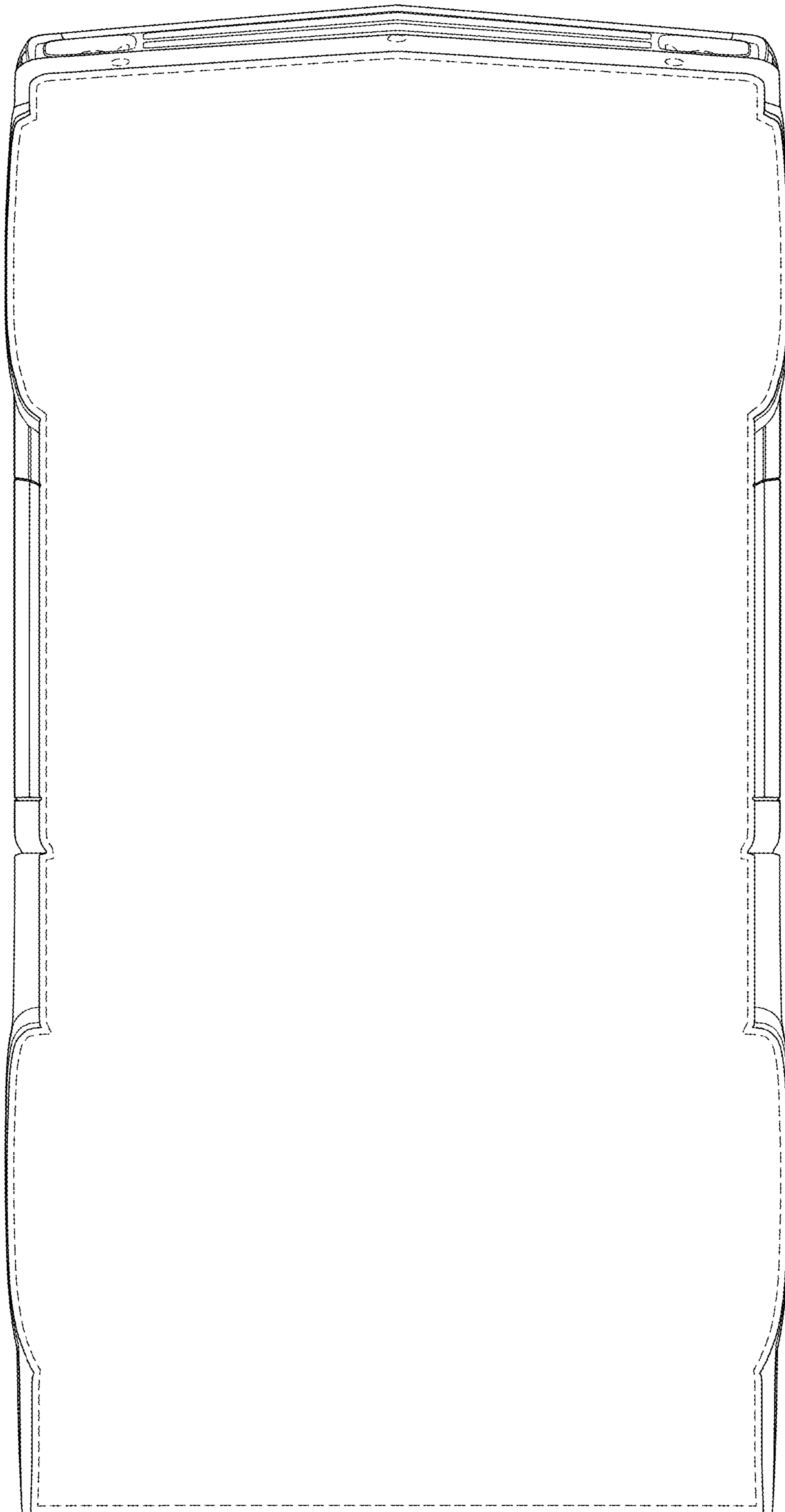

FIG. 7

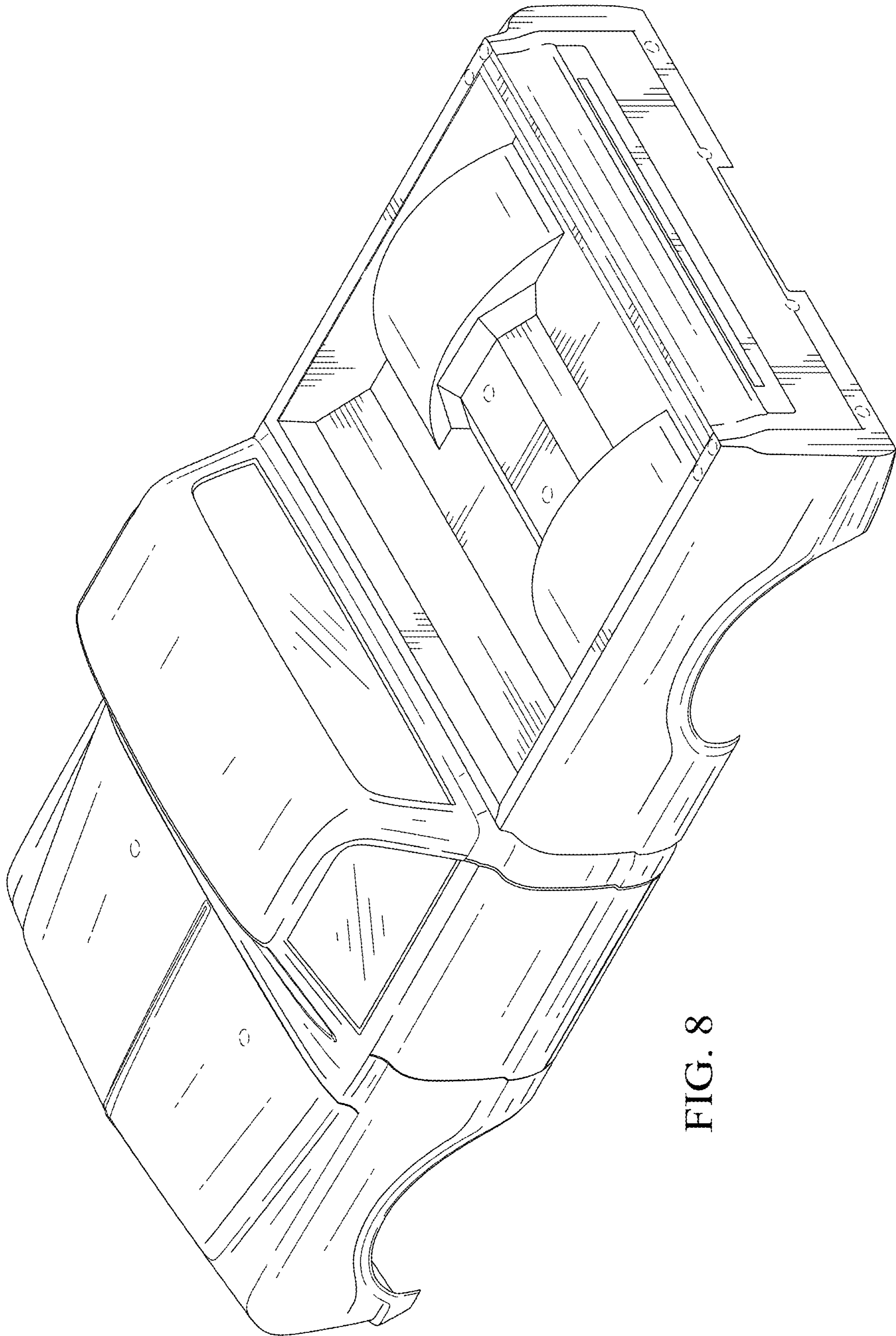

FIG. 8