



US00D947748S

(12) **United States Design Patent**
Levy et al.

(10) **Patent No.:** **US D947,748 S**
(45) **Date of Patent:** **** Apr. 5, 2022**

(54) **VERTICAL TAKE-OFF AND LANDING AIRCRAFT**

DESCRIPTION

(71) Applicant: **ISRAEL AEROSPACE INDUSTRIES LTD.**, Lod (IL)

(72) Inventors: **Sharon Levy**, Bat-Hefer (IL); **Ron Bublitsky**, Haifa (IL); **Ehud Baharav**, Ramat Gan (IL)

(73) Assignee: **ISRAEL AEROSPACE INDUSTRIES LTD.**, Lod (IL)

(**) Term: **15 Years**

(21) Appl. No.: **29/692,400**

(22) Filed: **May 24, 2019**

(30) **Foreign Application Priority Data**

Nov. 25, 2018 (IL) 62966
May 22, 2019 (IL) 63748

(51) **LOC (13) Cl.** **12-07**

(52) **U.S. Cl.**
USPC **D12/326**

(58) **Field of Classification Search**
USPC D12/1, 2, 3, 4, 16.1, 174, 319-345;
D15/436-455; D13/109

(Continued)

(56) **References Cited**

U.S. PATENT DOCUMENTS

9,120,560 B1 * 9/2015 Armer B64C 29/0008
10,081,436 B1 * 9/2018 Tian B64C 39/024

(Continued)

Primary Examiner — John A Voytek

(74) *Attorney, Agent, or Firm* — Vorys, Sater, Seymour & Pease LLP; William Klima

(57) **CLAIM**

The ornamental design for a vertical take-off and landing aircraft, as shown and described.

FIG. 1 is a front perspective view of a first embodiment for a new design for a vertical take-off and landing aircraft, with engines at vertical position;
FIG. 2 is a top view of the design seen in FIG. 1, with engines at vertical position;
FIG. 3 is a front view of the design seen in FIG. 1, with engines at vertical position;
FIG. 4 is a rear view of the design seen in FIG. 1, with engines at vertical position;
FIG. 5 is a right side view of the design seen in FIG. 1, with engines at vertical position;
FIG. 6 is a left side view of the design seen in FIG. 1, with engines at vertical position;
FIG. 7 is a bottom view of the design seen in FIG. 1, with engines at vertical position;
FIG. 8 is a bottom and rear perspective view of the design seen in FIG. 1, with engines at vertical position;
FIG. 9 is a bottom and rear perspective view of the design seen in FIG. 1, with engines at horizontal position;
FIG. 10 is a left and front perspective view of the design seen in FIG. 1, with engines at horizontal position;
FIG. 11 is a right and front perspective view of the design seen in FIG. 1, with engines at horizontal position;
FIG. 12 is a front perspective view of a second embodiment for a new design for a vertical take-off and landing aircraft with engines at vertical position;
FIG. 13 is a top view of the design seen in FIG. 12, with engines at vertical position;
FIG. 14 is a front view of the design seen in FIG. 12, with engines at vertical position;
FIG. 15 is a right side view of the design seen in FIG. 12, with engines at vertical position;
FIG. 16 is a rear view of the design seen in FIG. 12, with engines at vertical position;
FIG. 17 is a left side view of the design seen in FIG. 12, with engines at vertical position;
FIG. 18 is a top view of the design seen in FIG. 12, with engines at vertical position;
FIG. 19 is a bottom view of the design seen in FIG. 12, with engines at vertical position;
FIG. 20 is a bottom and rear perspective view of the design seen in FIG. 12, with engines at vertical position;

(Continued)

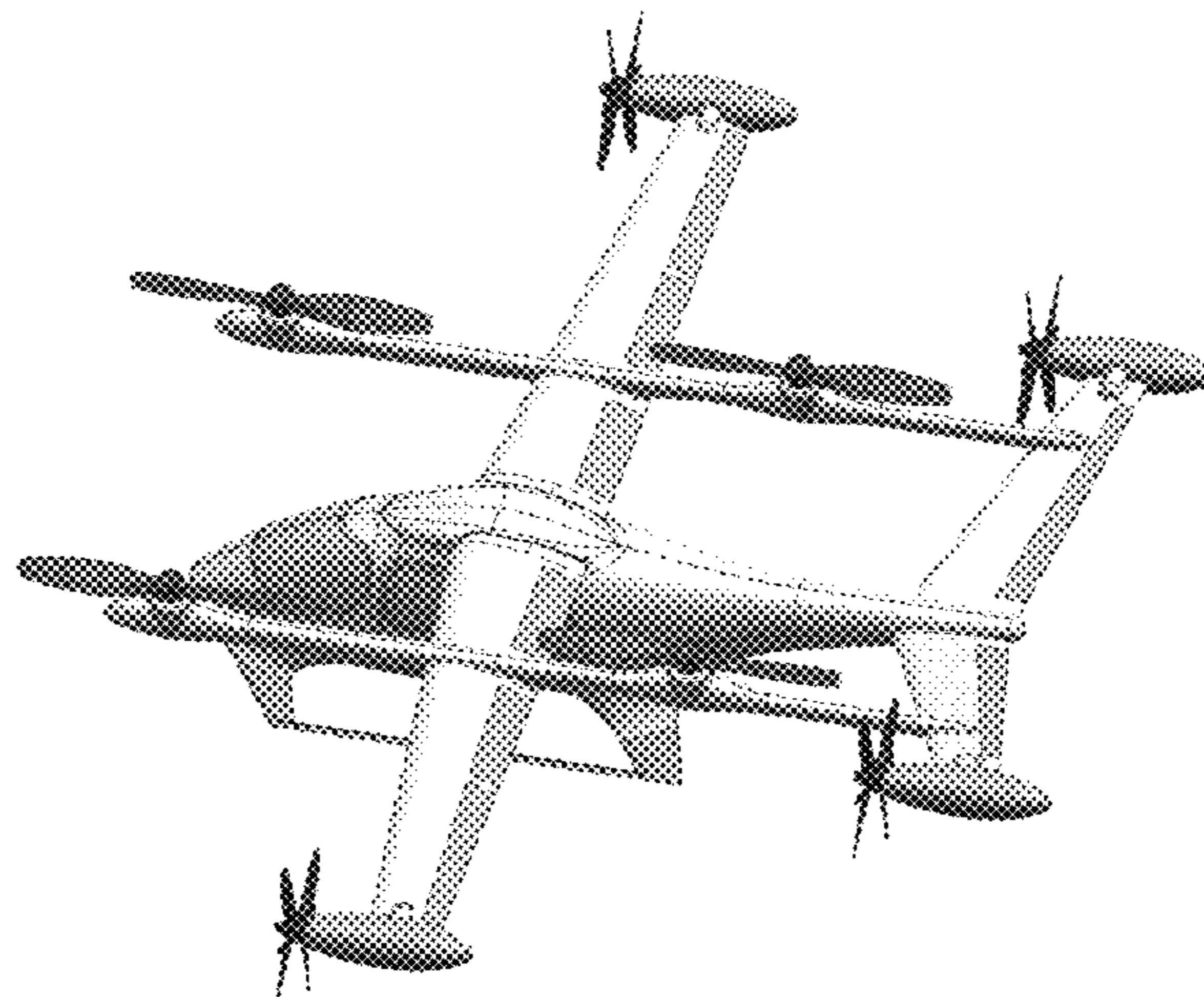

FIG. 21 is a bottom and left perspective view of the design seen in FIG. 12, with engines at horizontal position; and, FIG. 22 is a top and rear perspective view of the design seen in FIG. 12, with engines at horizontal position.

The part of the photograph shown in a coarse dot pattern, along with the broken-line perimeter illustrates a portion of the vertical take-off and landing aircraft vehicle that forms no part of the claimed design.

1 Claim, 22 Drawing Sheets

(58) **Field of Classification Search**

CPC B64C 29/0033; B64C 2201/021; B64C
29/02; B64C 2201/088; B64C 2201/104;
B64C 2201/141

See application file for complete search history.

(56) **References Cited**

U.S. PATENT DOCUMENTS

D832,154 S * 10/2018 Tian D12/161
D843,306 S * 3/2019 Tzarnotzky D12/329
D850,357 S * 6/2019 Cummings D12/326
10,322,814 B1 * 6/2019 Tian B64C 39/04
D864,084 S * 10/2019 Clark D12/328
D868,668 S * 12/2019 Parvizian D12/328
D872,681 S * 1/2020 Tzarnotzky D12/329
D875,022 S * 2/2020 Cummings D12/326
2016/0236774 A1 * 8/2016 Niedzballa B64D 27/24
2017/0300066 A1 * 10/2017 Douglas G05D 1/0858

* cited by examiner

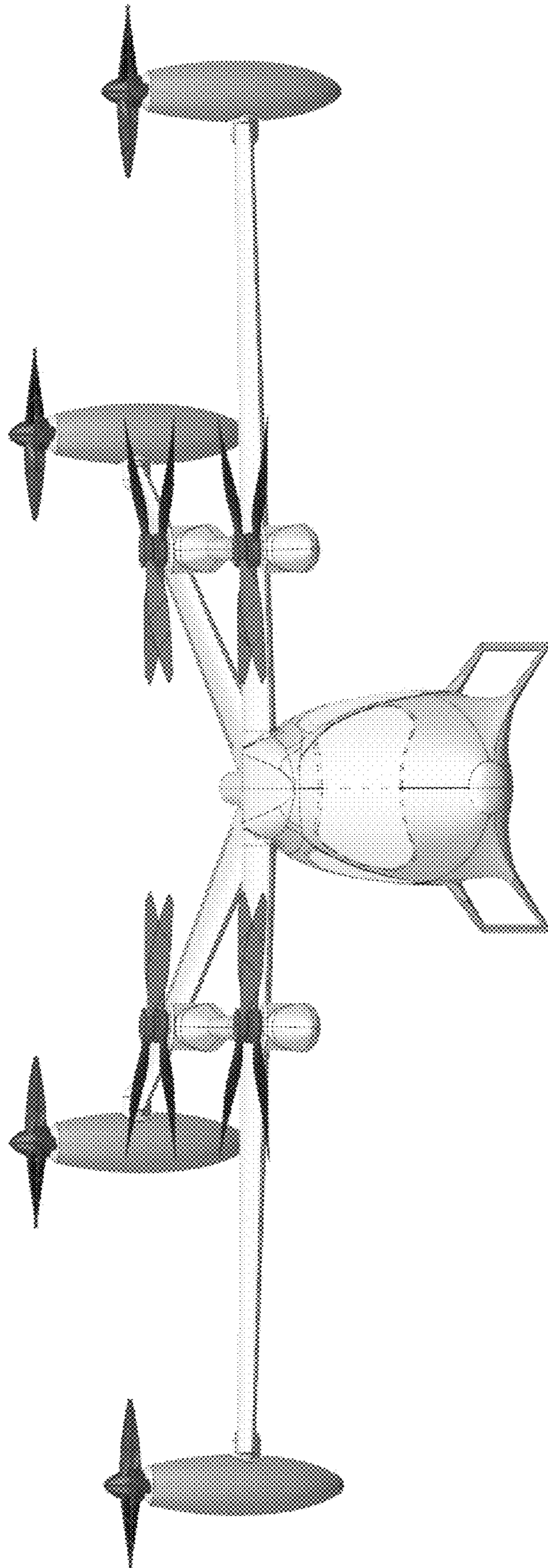

FIG. 1

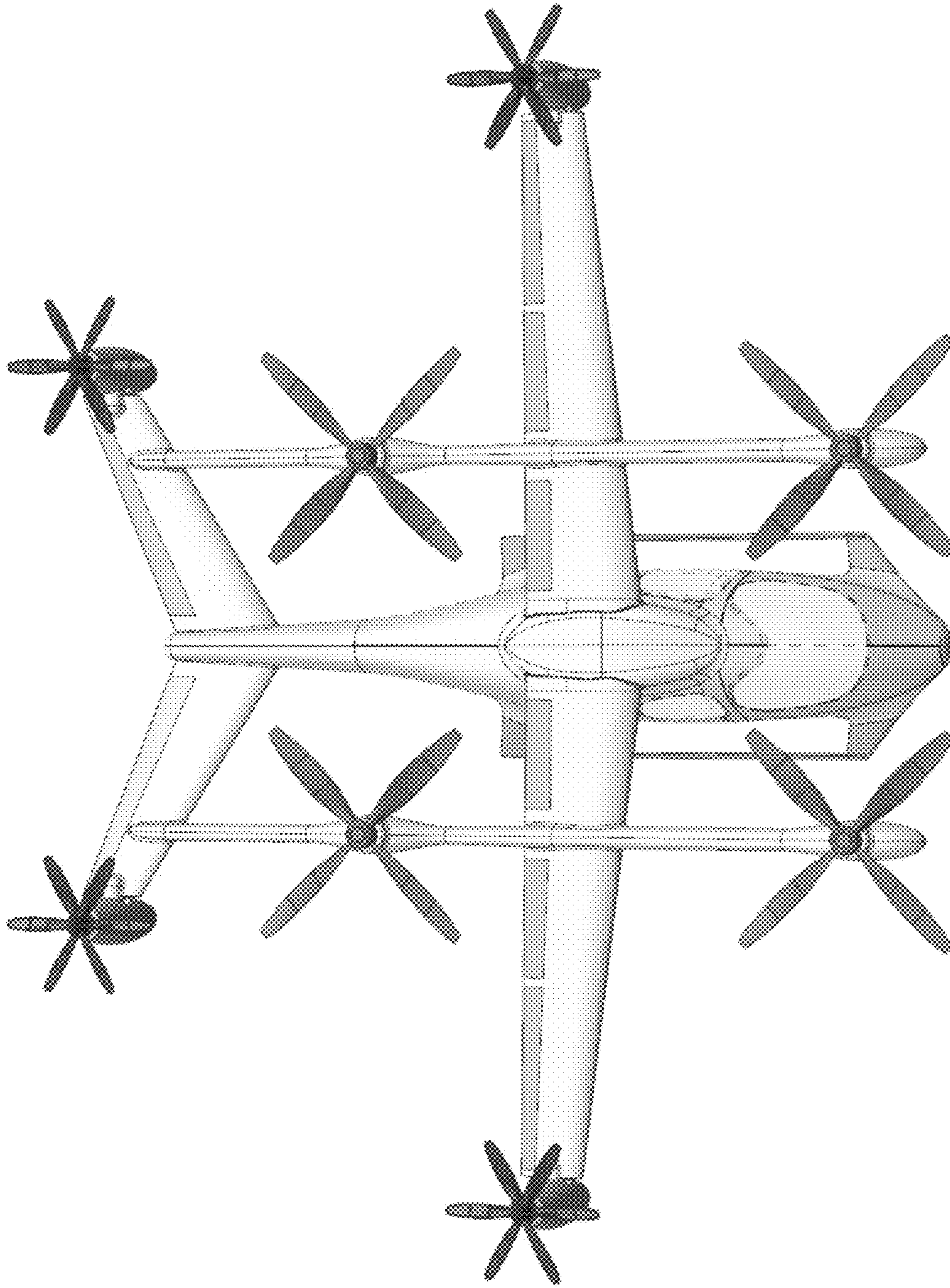

FIG. 2

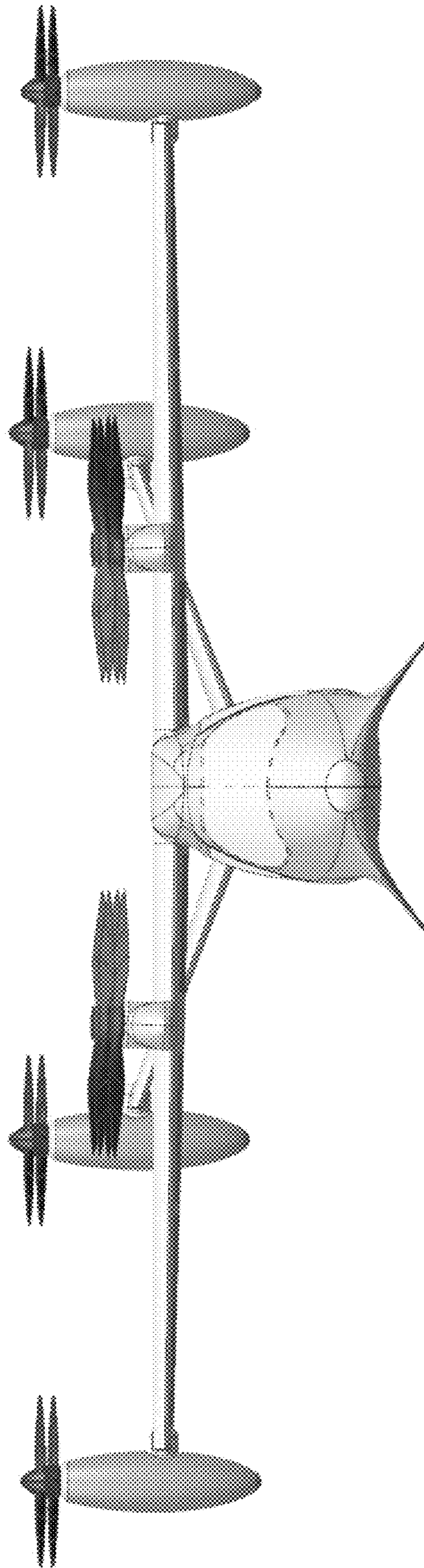

FIG. 3

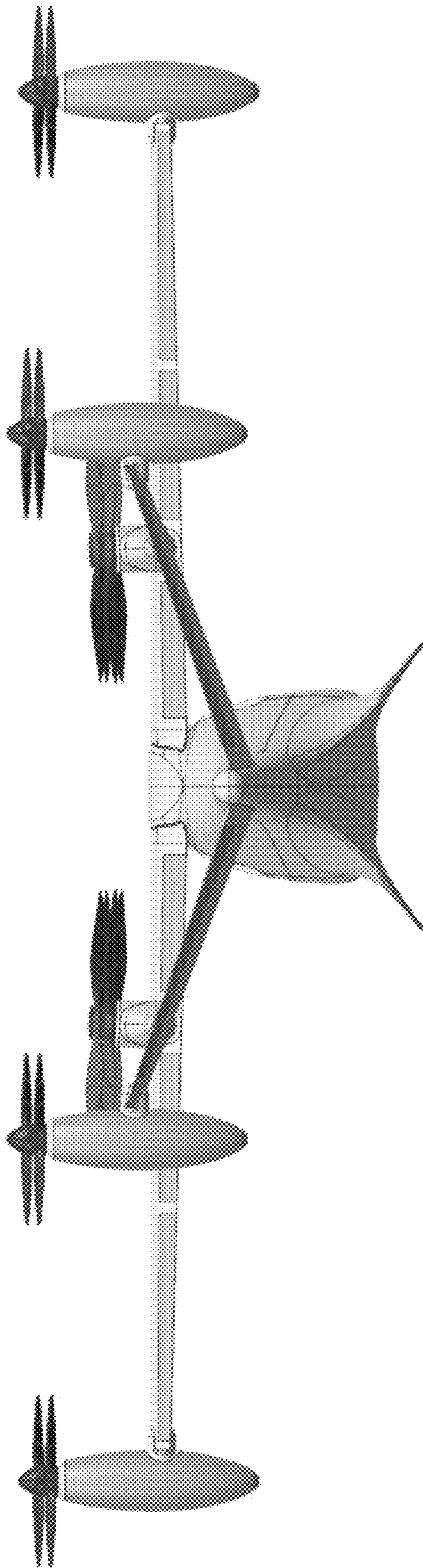

FIG. 4

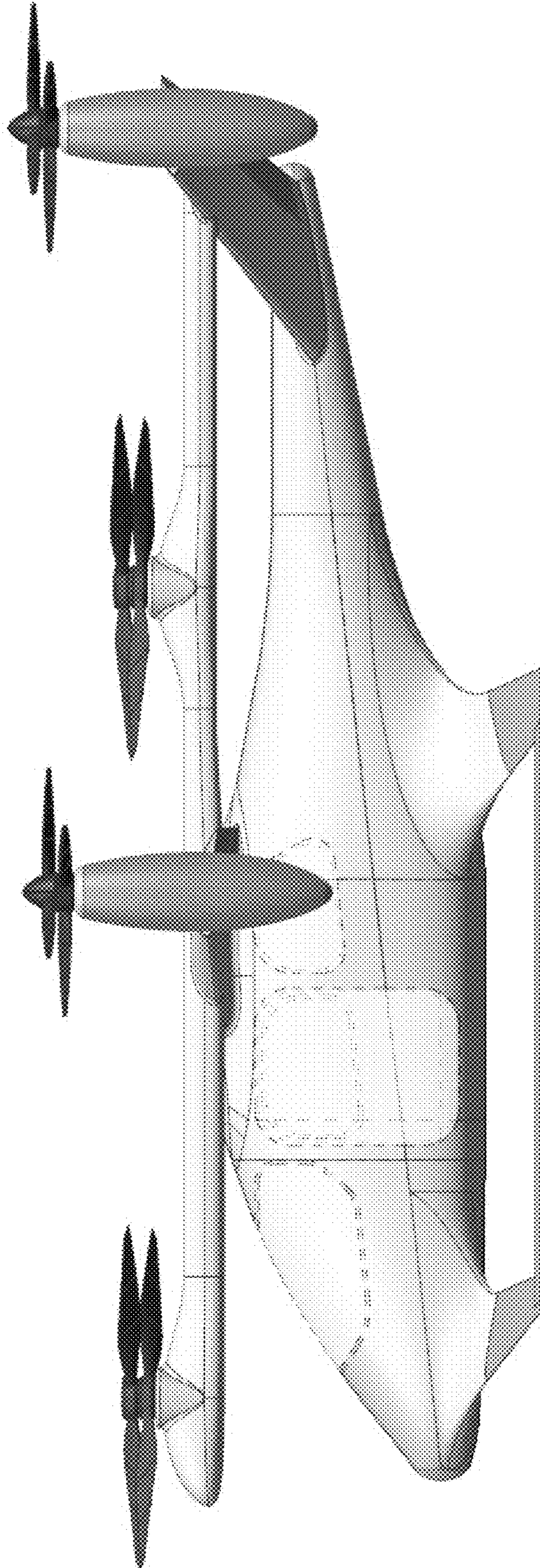

FIG. 5

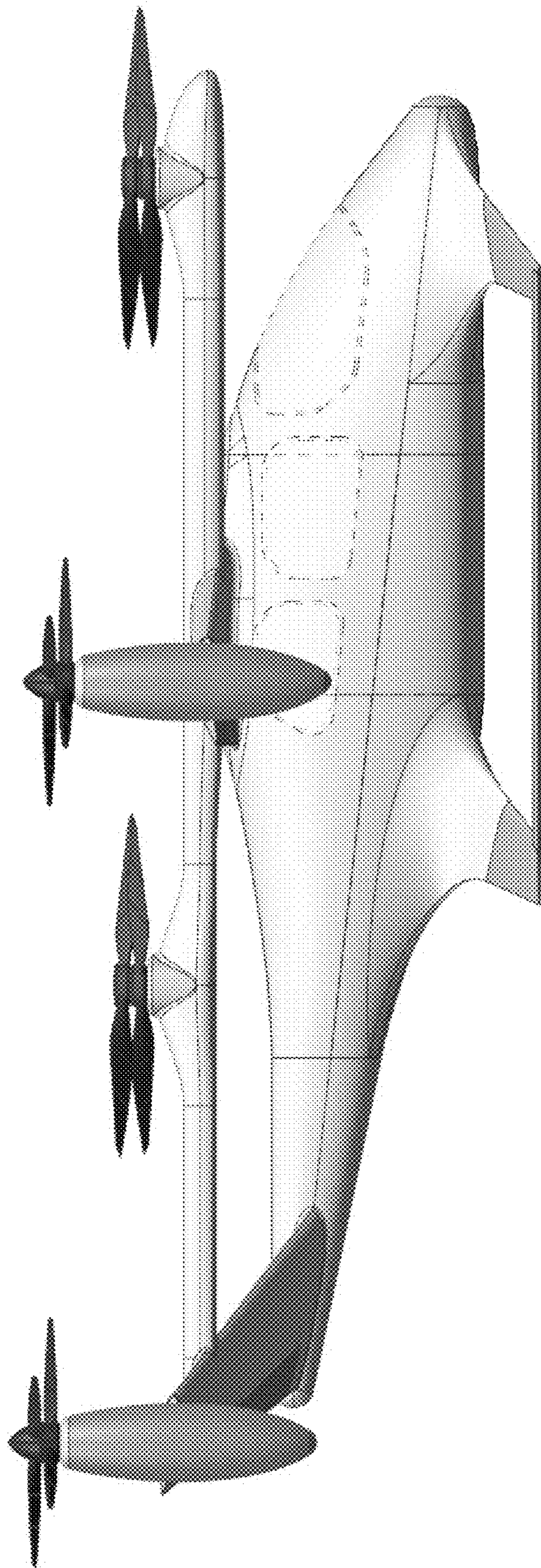

FIG. 6

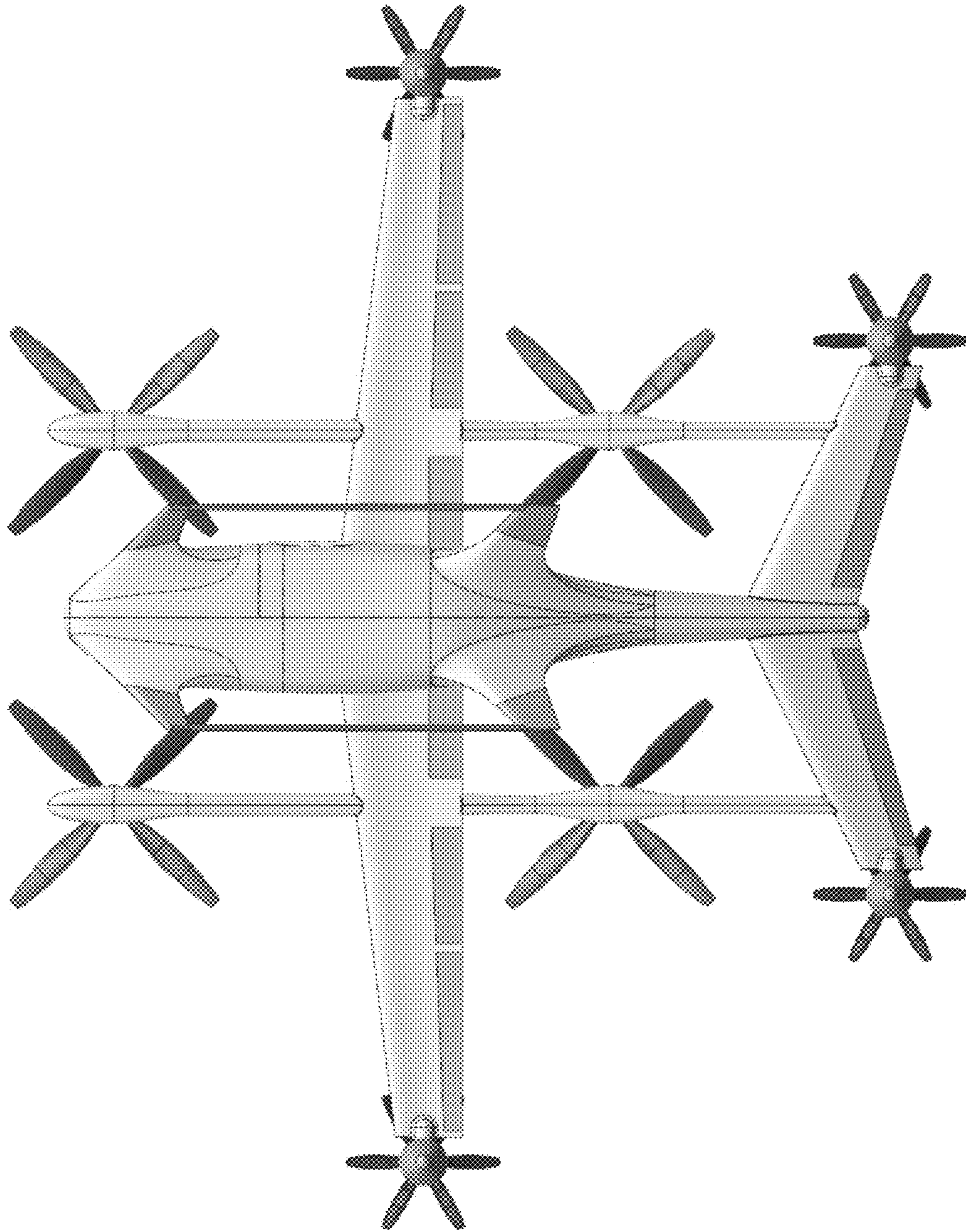

FIG. 7

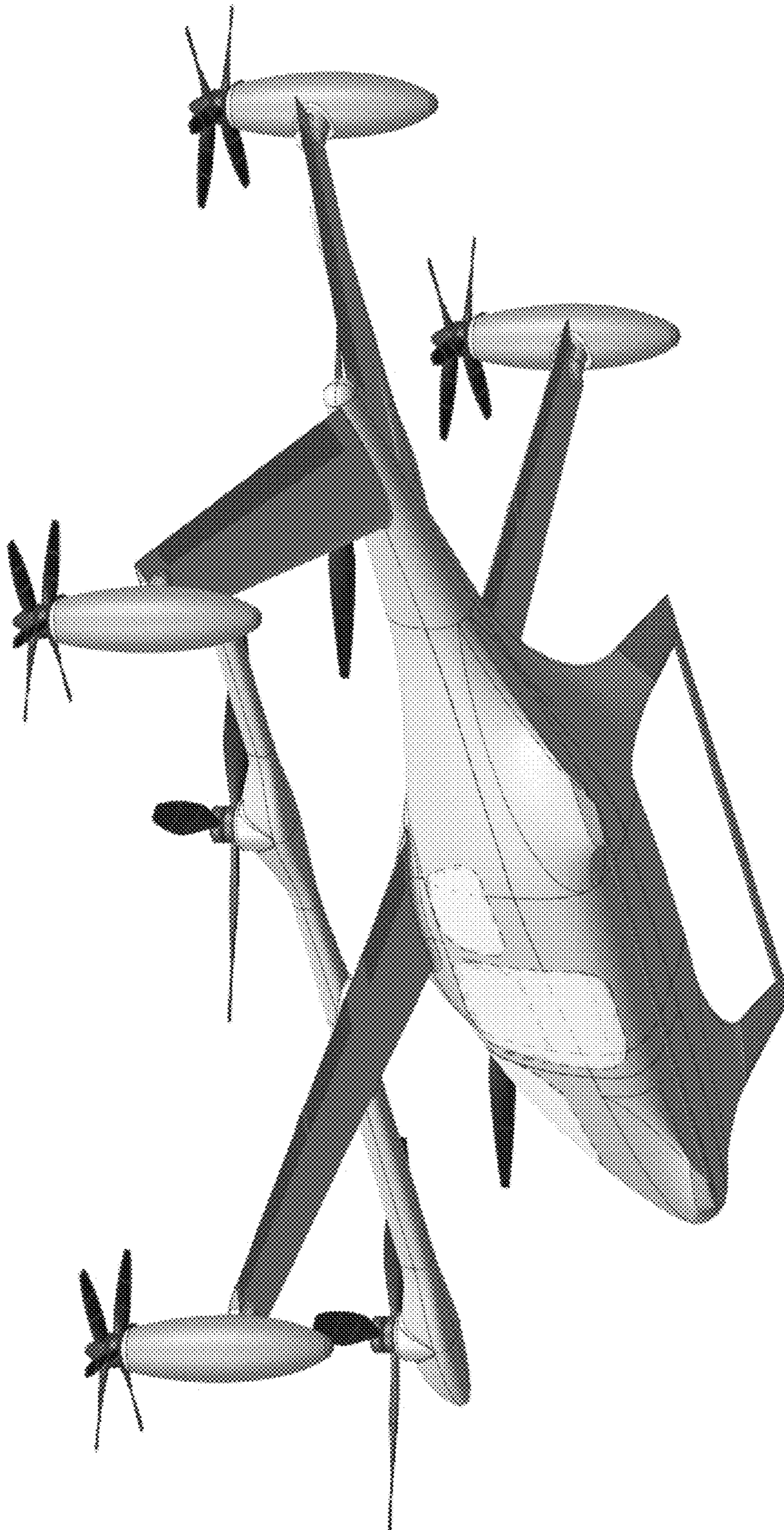

FIG. 8

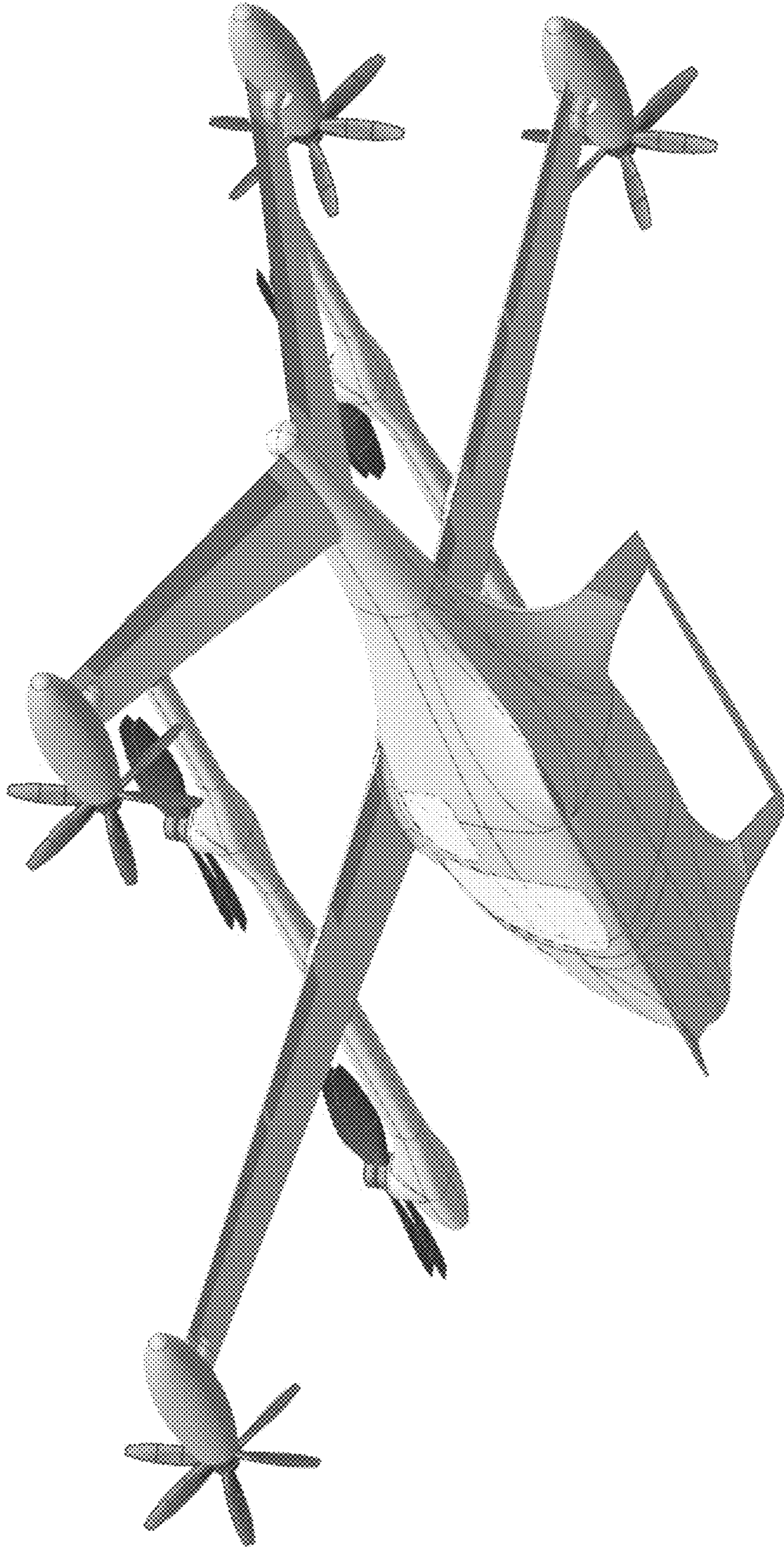

FIG. 9

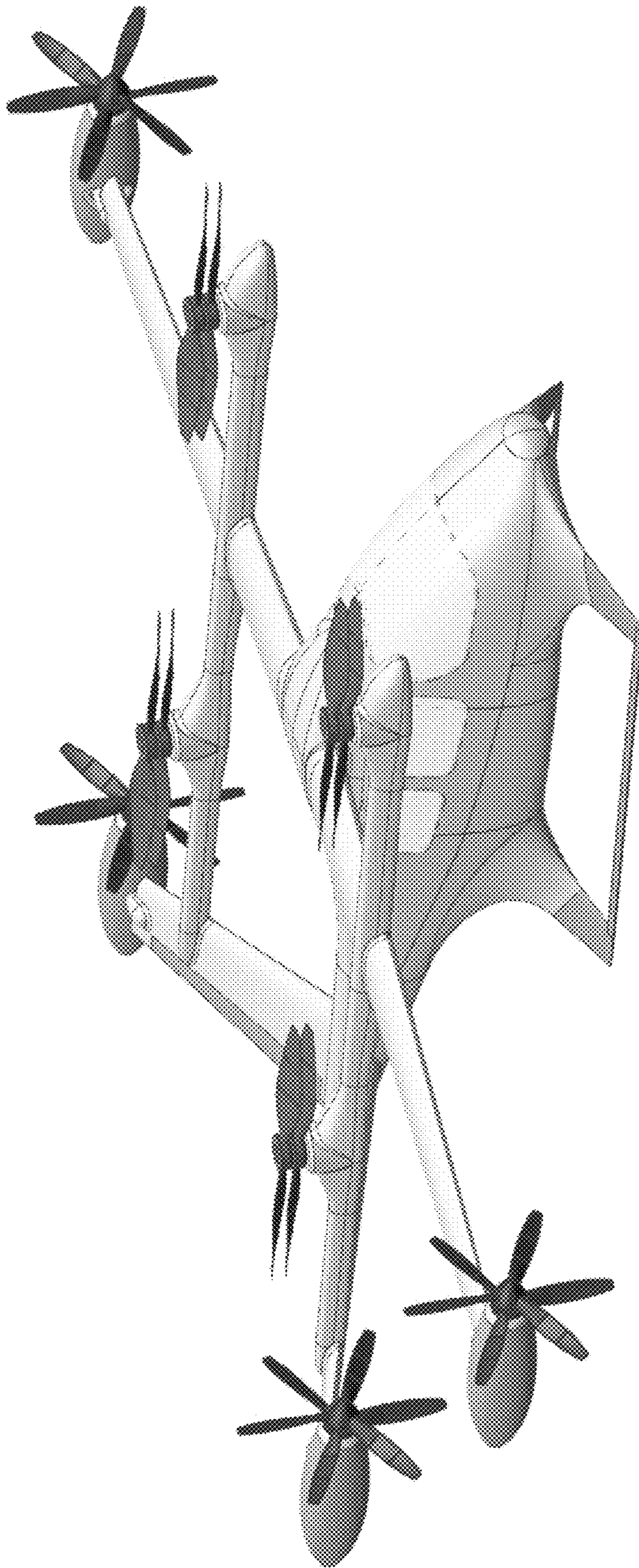

FIG. 10

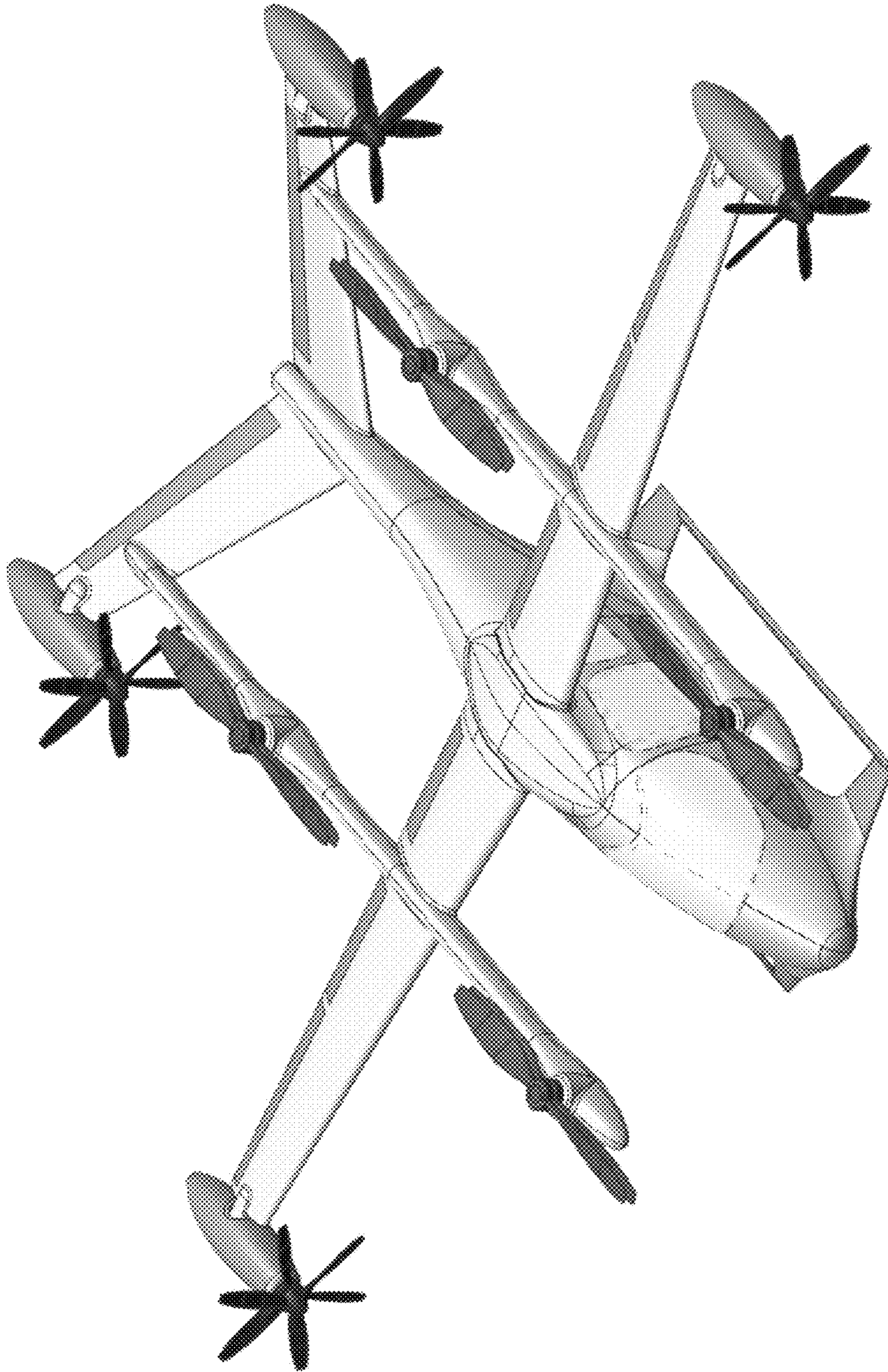

FIG. 11

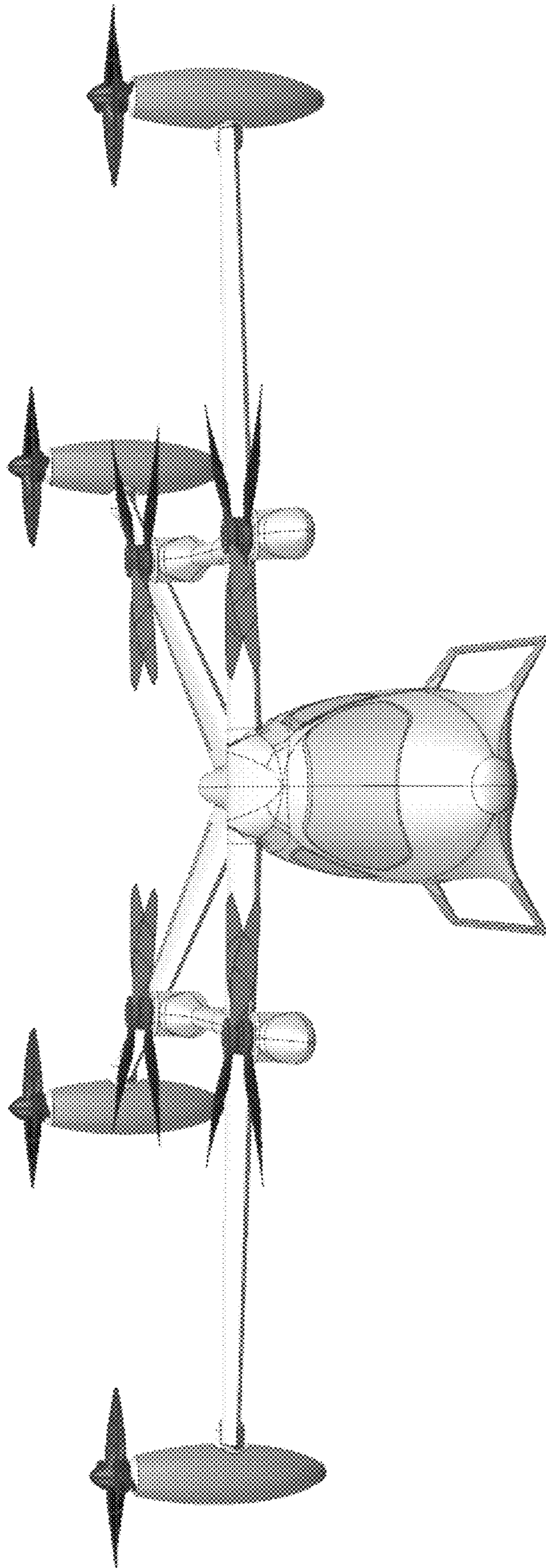

FIG. 12

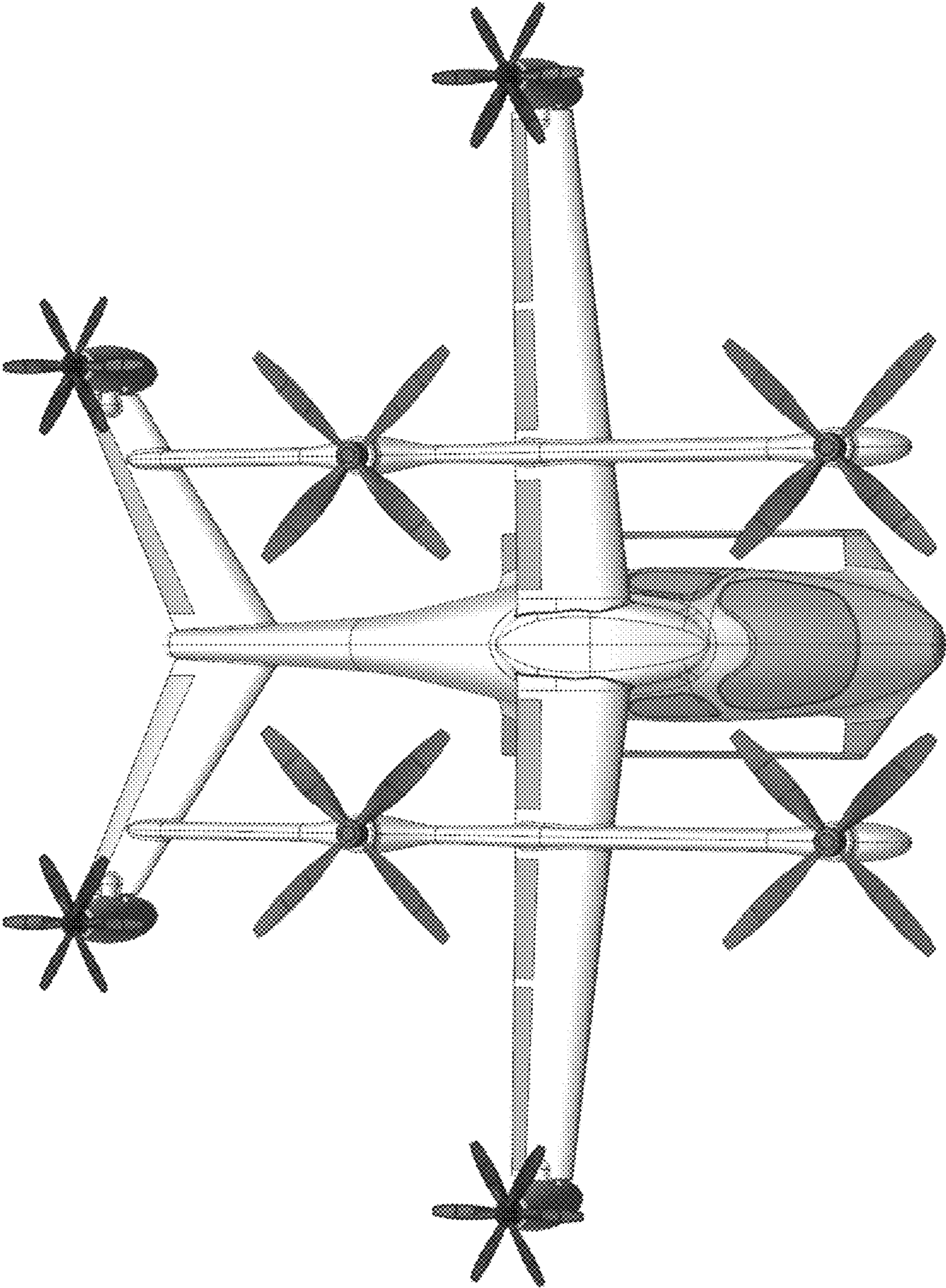

FIG. 13

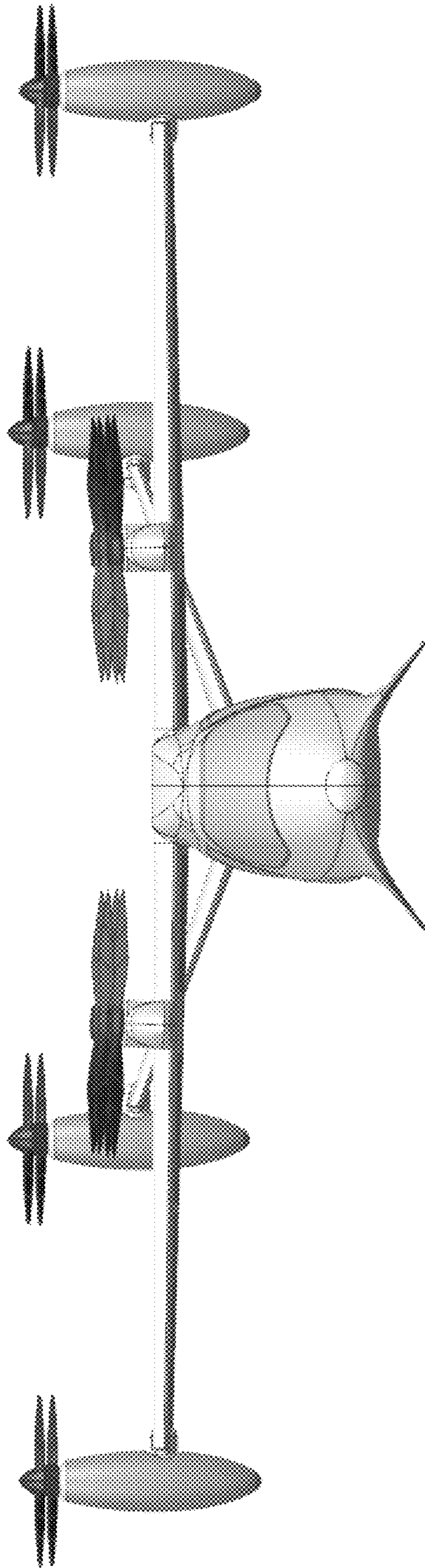

FIG. 14

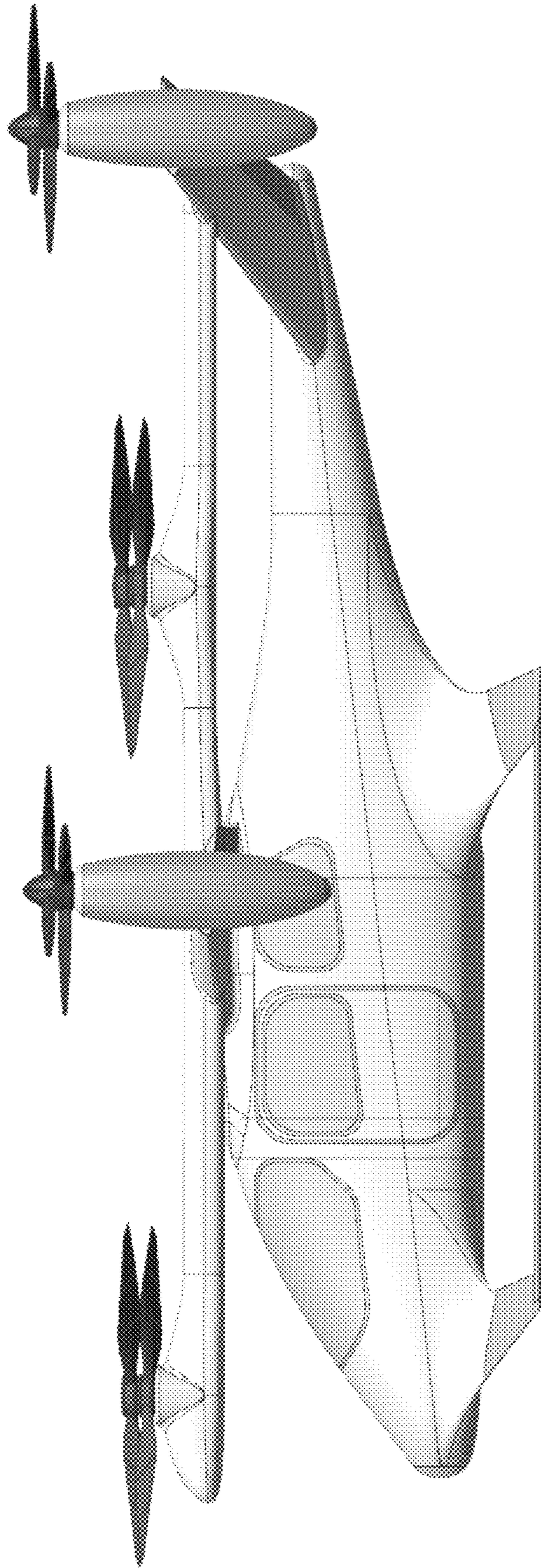

FIG. 15

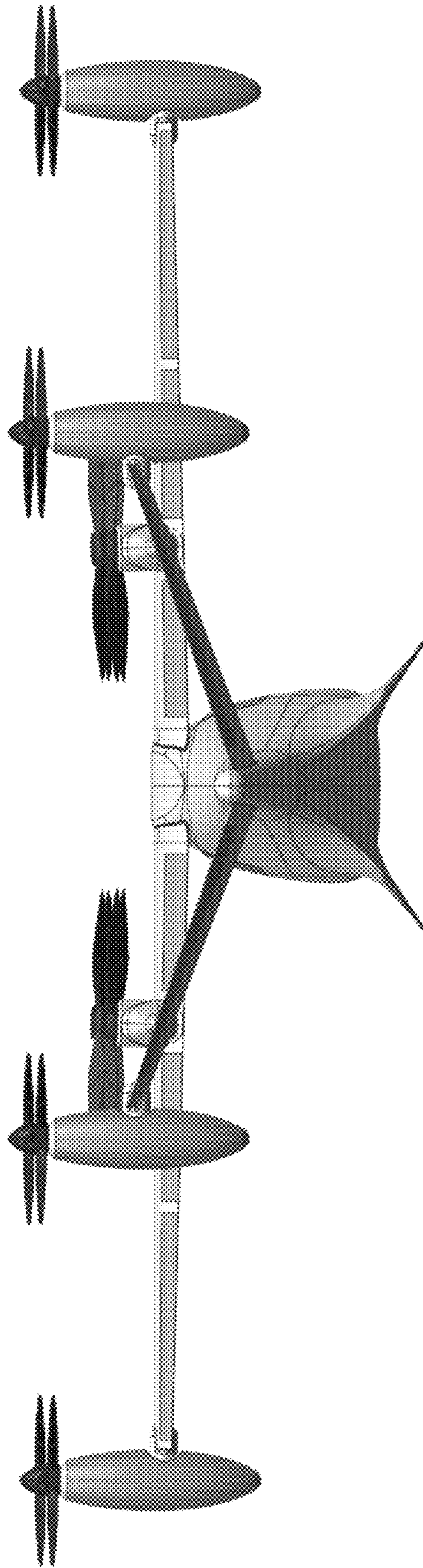

FIG. 16

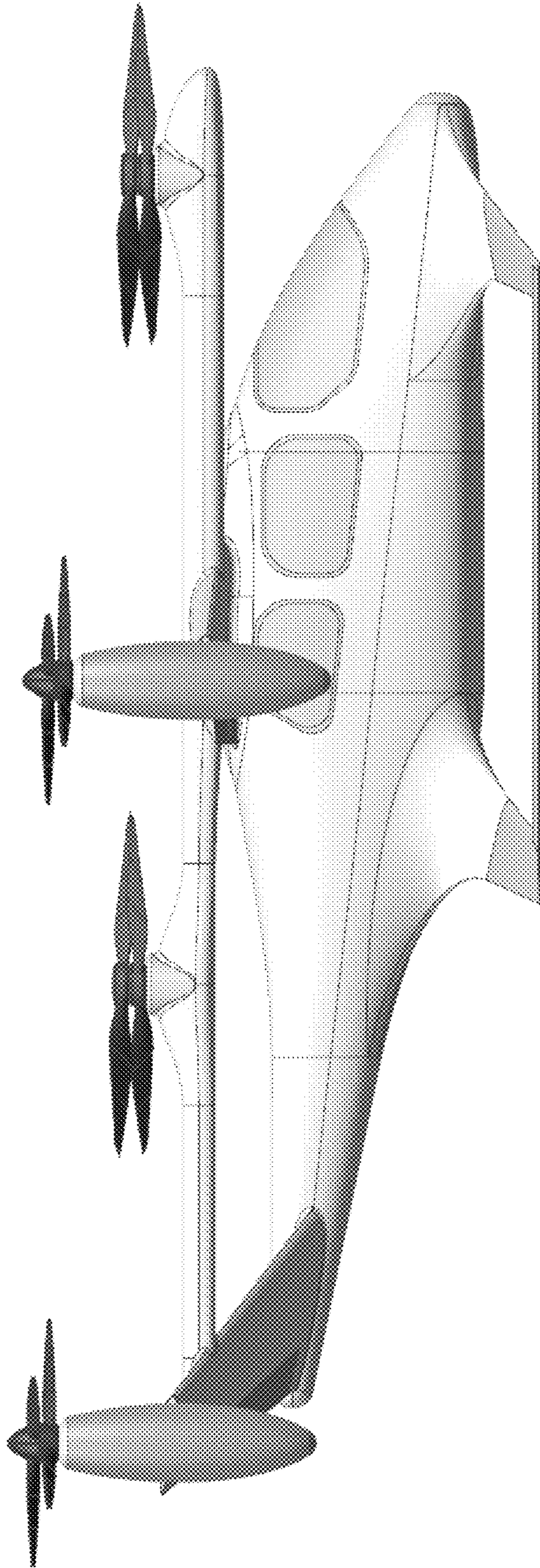

FIG. 17

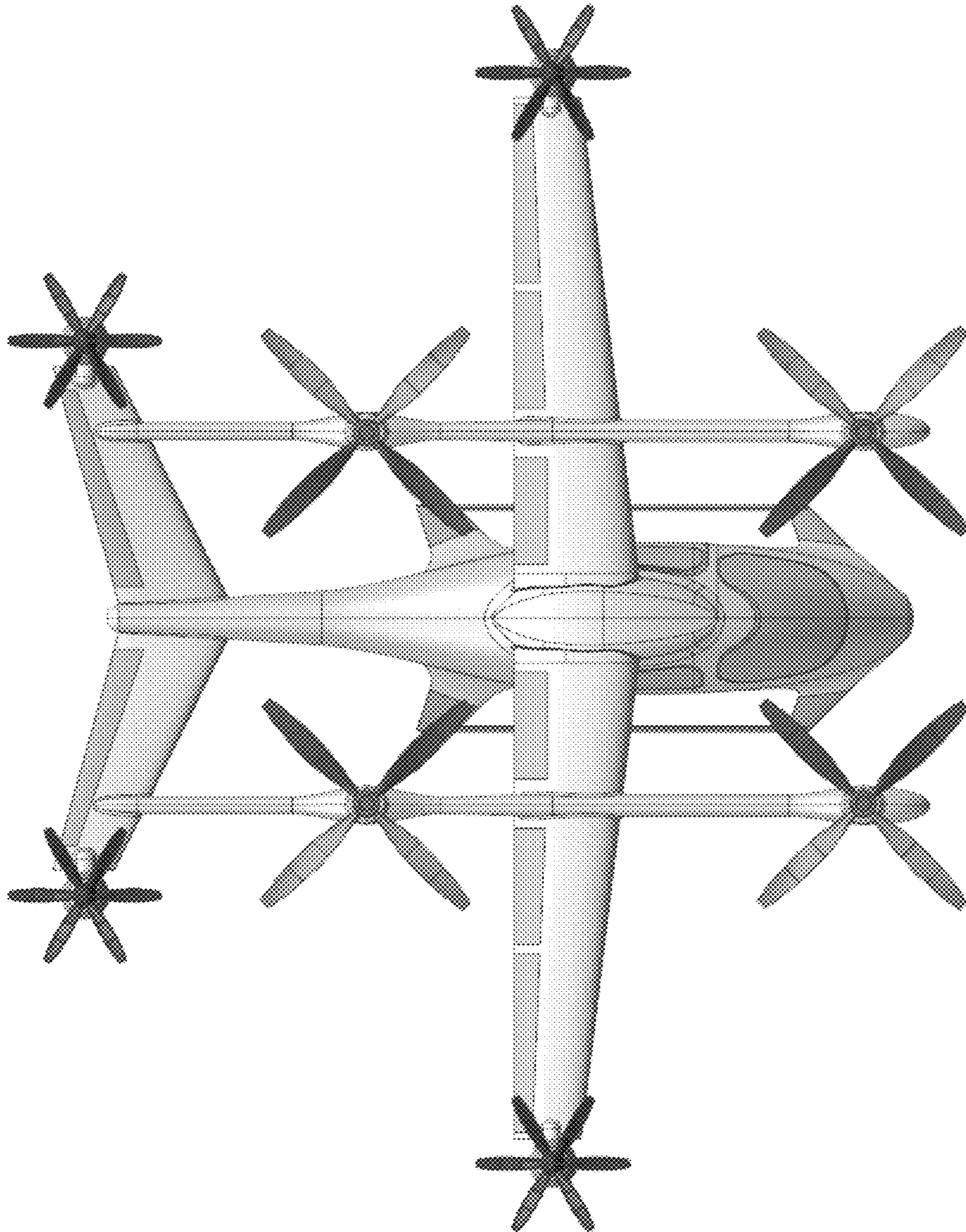

FIG. 18

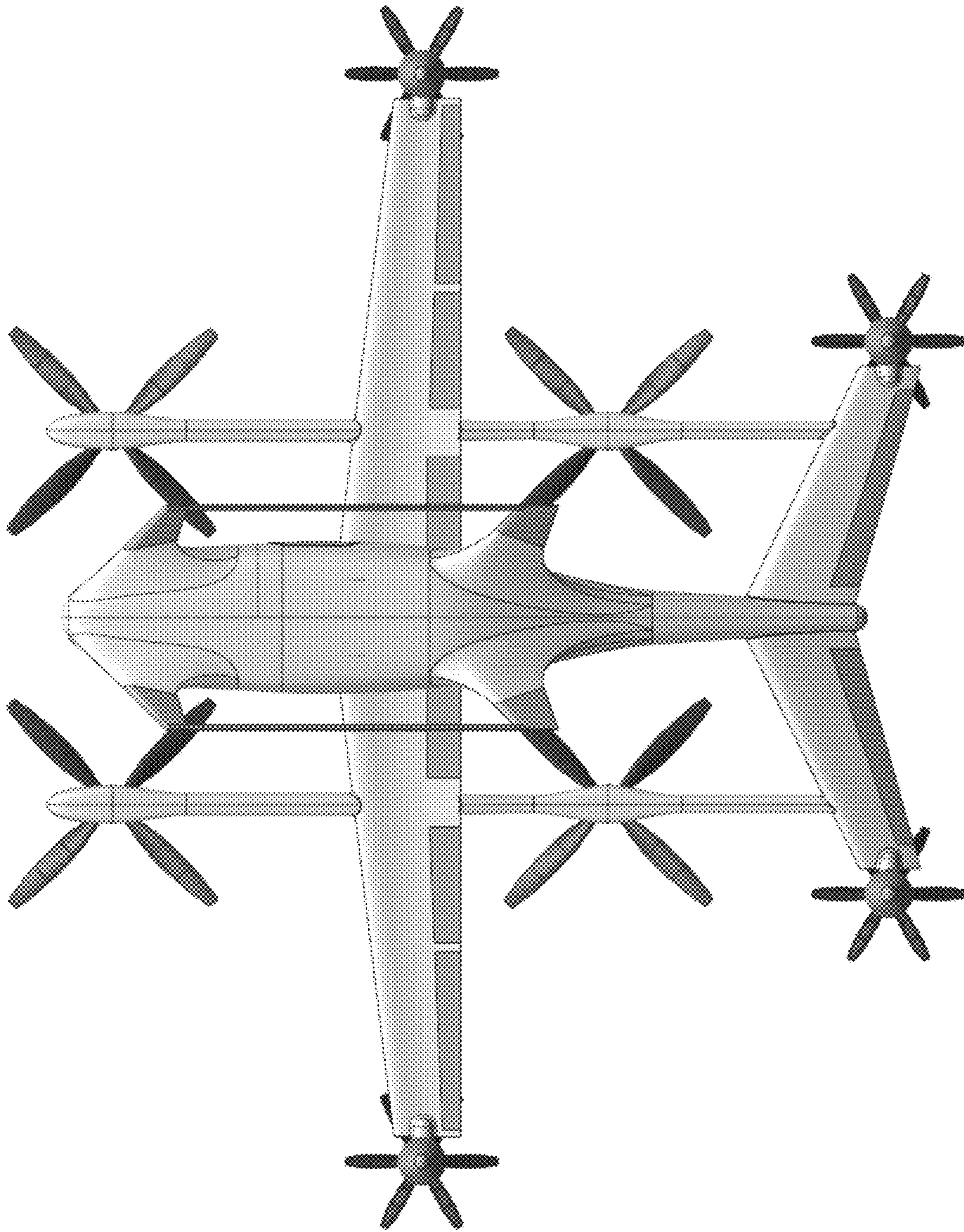

FIG. 19

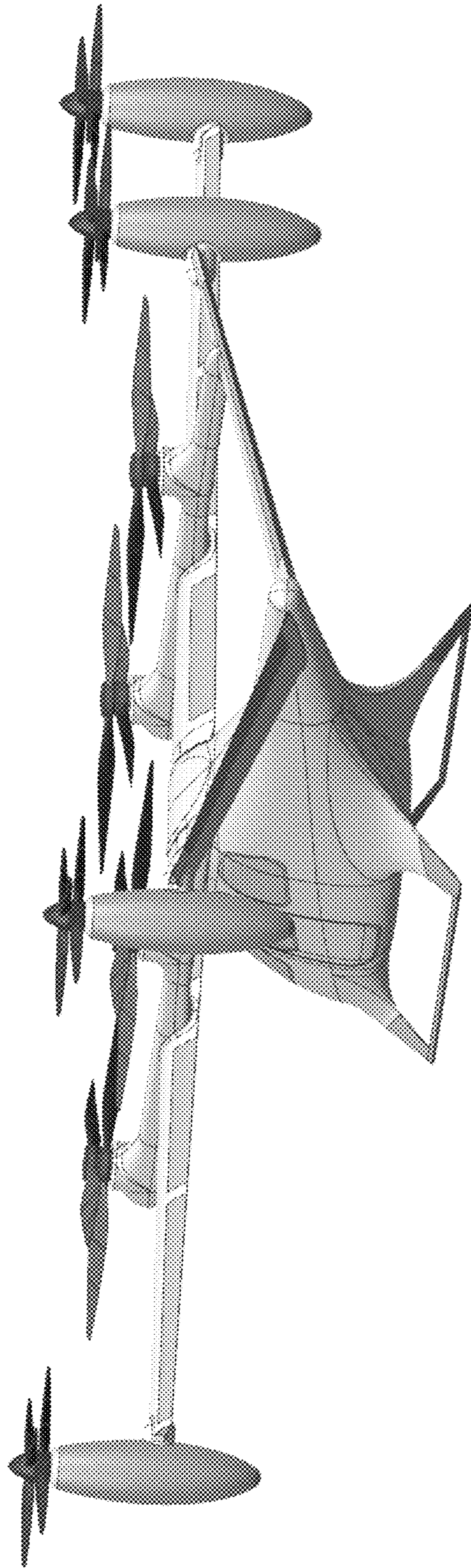

FIG. 20

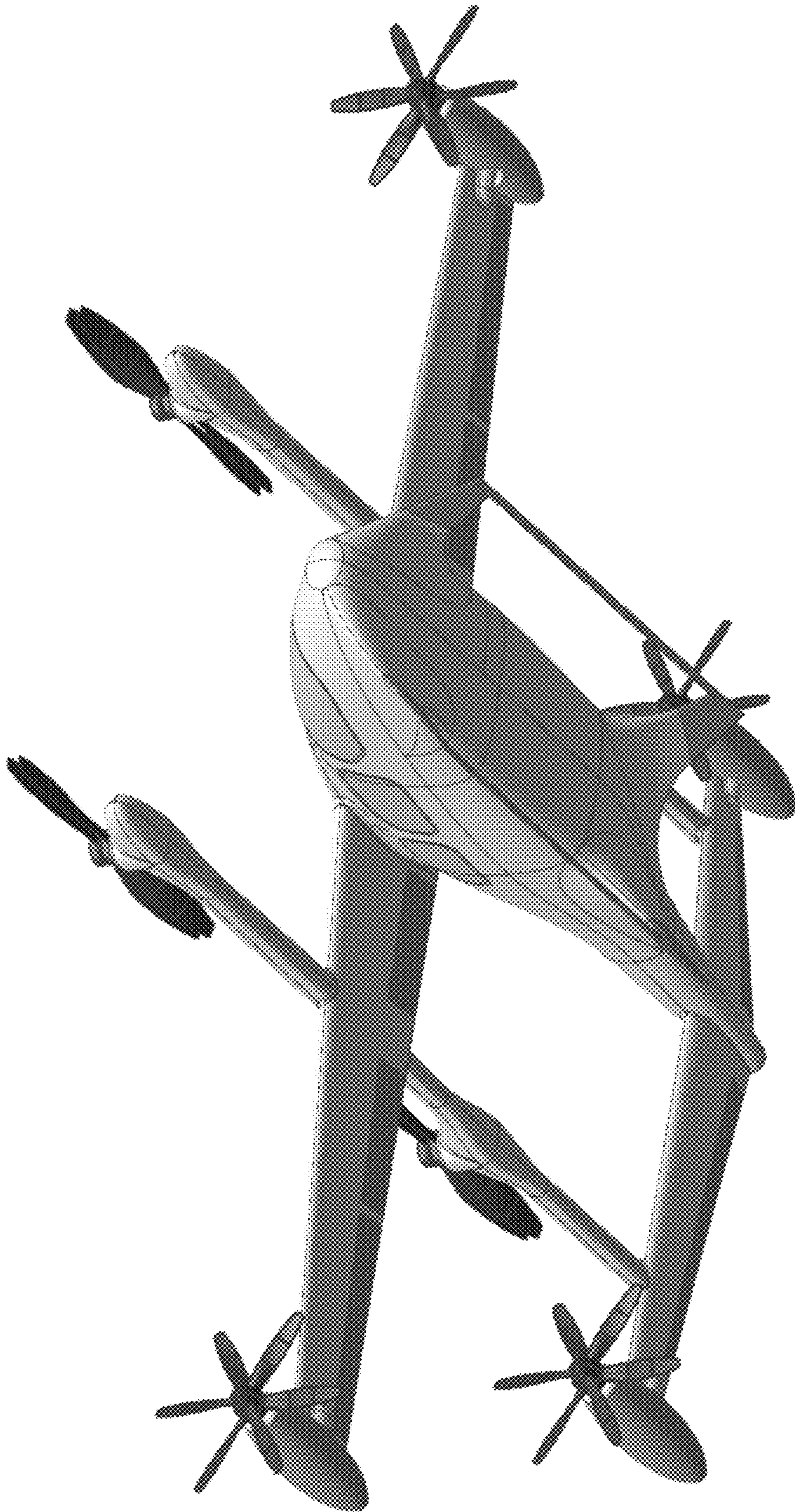

FIG. 21

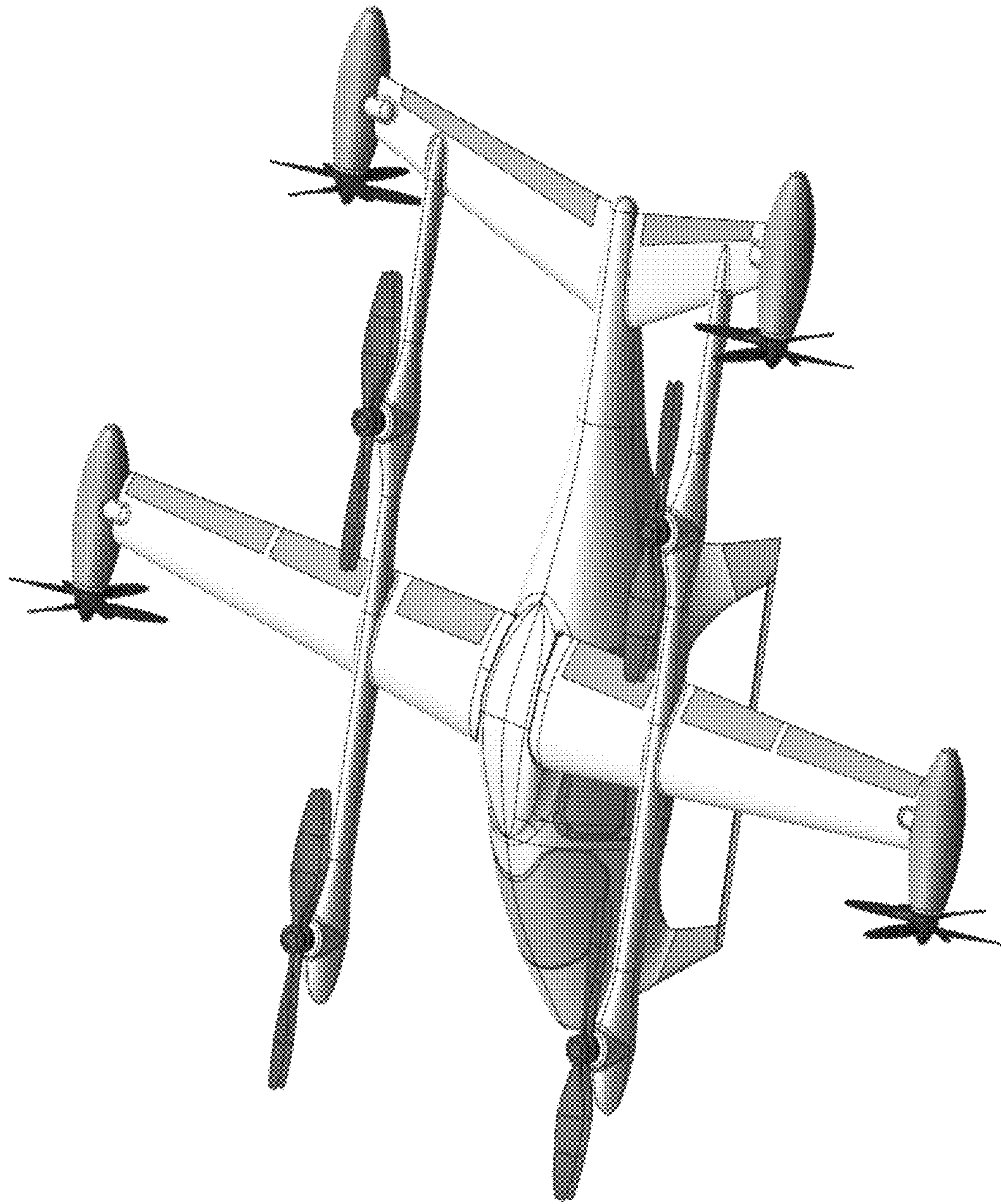

FIG. 22