

US00D947725S

(12) **United States Design Patent**
Koshiishi

(10) **Patent No.:** **US D947,725 S**
(45) **Date of Patent:** **** Apr. 5, 2022**

(54) **SPORTS-SPECIFIC WHEELCHAIR**

(71) Applicant: **HONDA MOTOR CO., LTD.**, Tokyo
(JP)

(72) Inventor: **Takeshi Koshiishi**, Wako (JP)

(73) Assignee: **HONDA MOTOR CO., LTD.**, Tokyo
(JP)

(**) Term: **15 Years**

(21) Appl. No.: **29/728,935**

(22) Filed: **Mar. 23, 2020**

(30) **Foreign Application Priority Data**

Sep. 24, 2019 (JP) 2019-021185

(51) **LOC (13) Cl.** **12-12**

(52) **U.S. Cl.**
USPC **D12/131**

(58) **Field of Classification Search**

USPC D12/1, 110, 111, 114, 117, 128, 129,
D12/130, 131, 132, 133; D21/432, 538,
D21/686, 687, 689, 690, 691, 760, 763,
D21/765

CPC . A61G 5/00; A61G 5/02; A61G 5/021; A61G
5/022; A61G 5/04; A61G 5/041; A61G
5/042; A61G 5/043; A61G 5/045; A61G
5/046; A61G 5/047; A61G 5/048; A61G
5/10; A61G 5/1051; A61G 5/128; B62K
17/00; B62K 19/00

See application file for complete search history.

(56) **References Cited**

U.S. PATENT DOCUMENTS

D465,753 S * 11/2002 Hamann D12/117
D488,109 S * 4/2004 Koshiishi D12/131
D506,165 S * 6/2005 Koike D12/131

D596,536 S * 7/2009 Katagiri D12/126
D726,594 S * 4/2015 Nishimoto D12/126
D876,993 S * 3/2020 Koshiishi D12/131
2018/0185209 A1 * 7/2018 Fontanesi A61G 5/021
2019/0389246 A1 * 12/2019 Koshido B60B 5/02

OTHER PUBLICATIONS

Honda Wheelchair, Published date unavailable [online], [retrieved on Nov. 9, 2021]. Retrieved from the Internet: <https://racer.honda-sun.co.jp/en/> (Year: 2021).*

* cited by examiner

Primary Examiner — Cary M Robinson

Assistant Examiner — Adam C Mager

(74) *Attorney, Agent, or Firm* — Westerman, Hattori,
Daniels & Adrian, LLP

(57) **CLAIM**

The ornamental design for a sports-specific wheelchair, as shown and described.

DESCRIPTION

FIG. 1 is a first perspective view of a sports-specific wheelchair, showing our new design;

FIG. 2 is a second perspective view thereof;

FIG. 3 is a third perspective view thereof;

FIG. 4 is a front elevational view thereof;

FIG. 5 is a top plan, view thereof;

FIG. 6 is a bottom plan view thereof;

FIG. 7 is a right side elevational view thereof;

FIG. 8 is a left side elevational view thereof; and,

FIG. 9 is a partially enlarged view thereof.

The broken lines in the drawings illustrate portions of a sports-specific wheelchair that form no part of the claimed design. The shades of gray as well as the shadows and reflections represent contour and not surface ornamentation or any particular color.

1 Claim, 9 Drawing Sheets

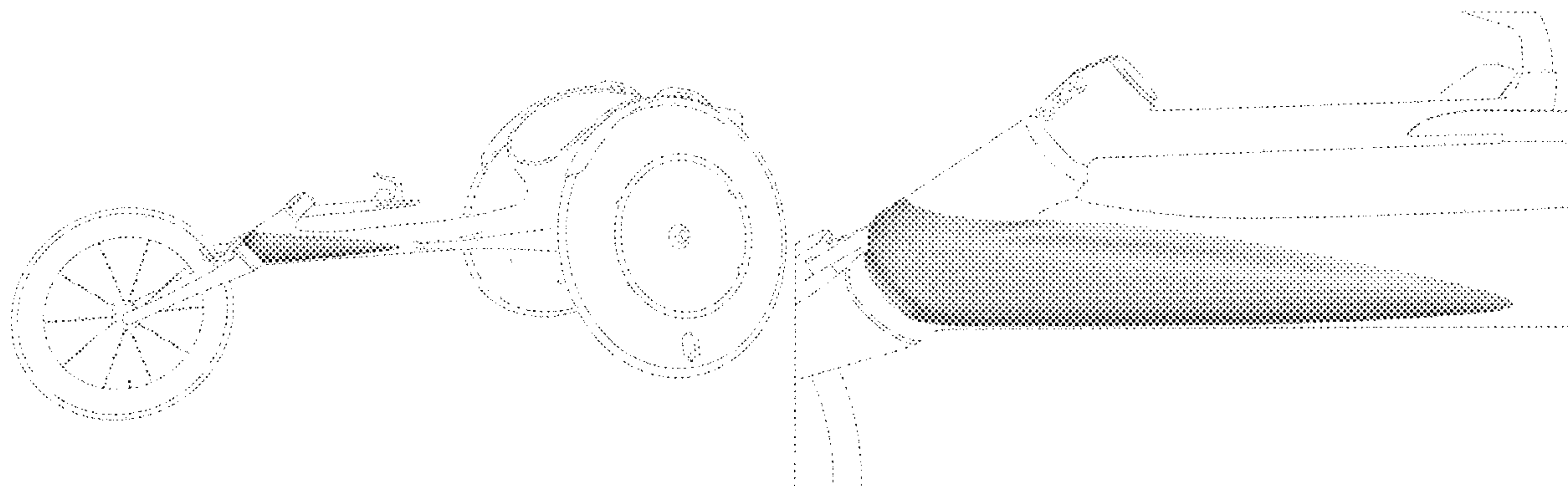

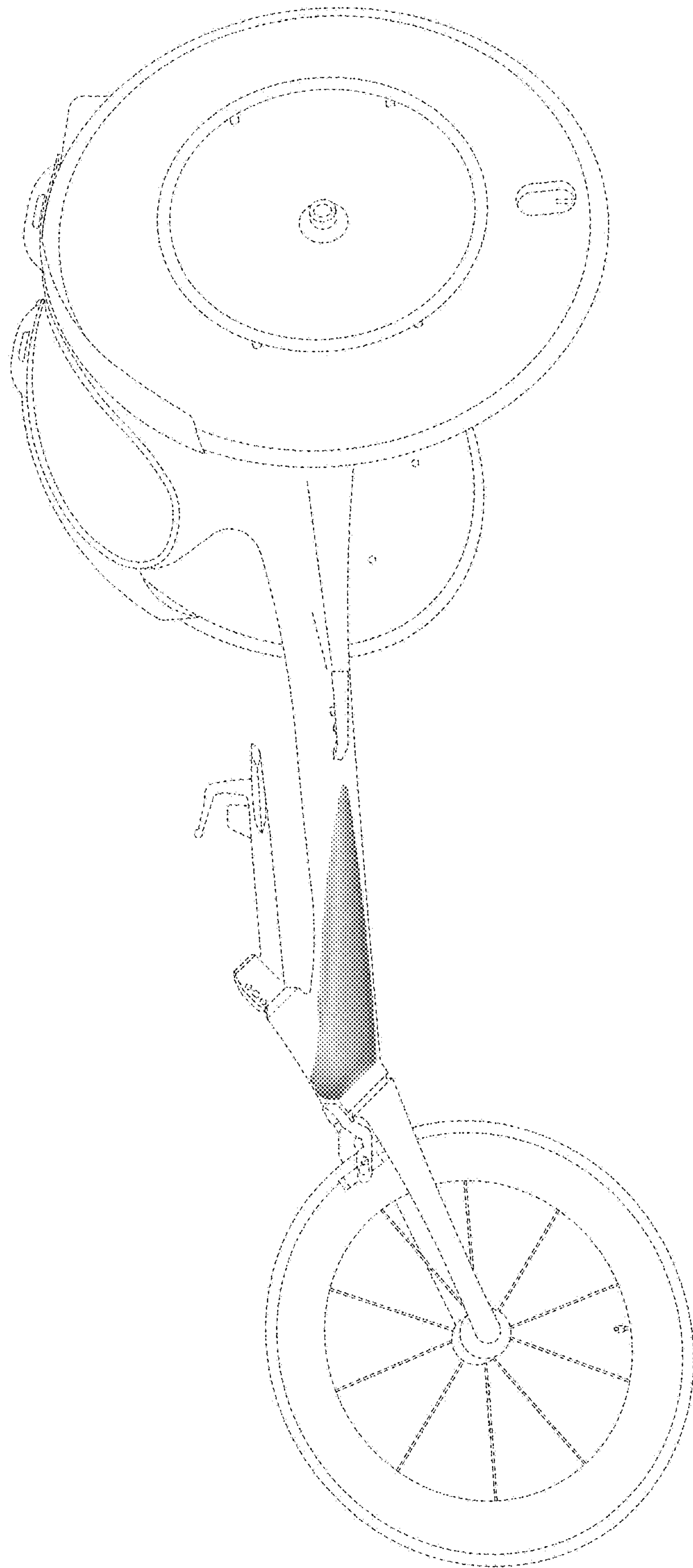
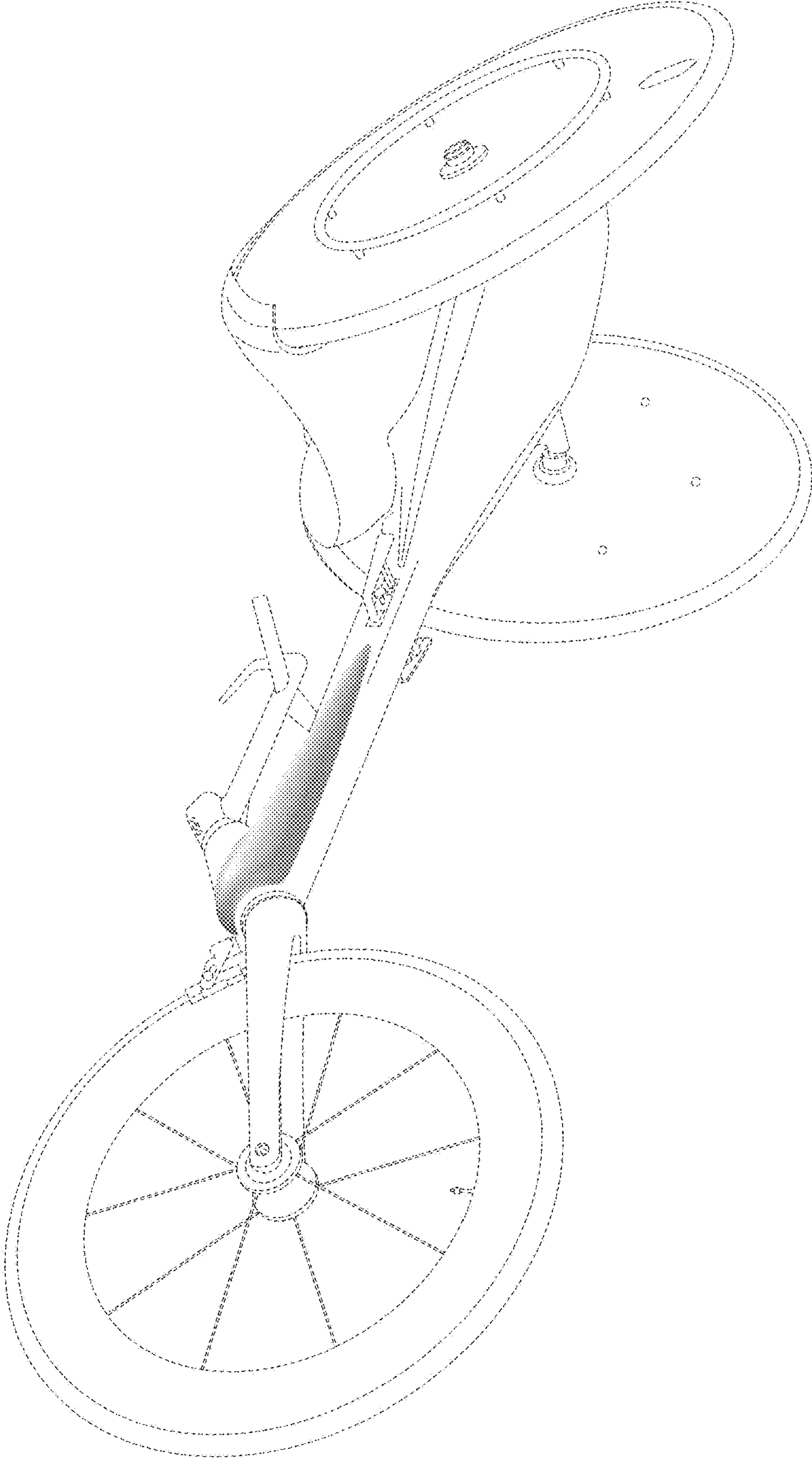

Fig.1

Fig.2



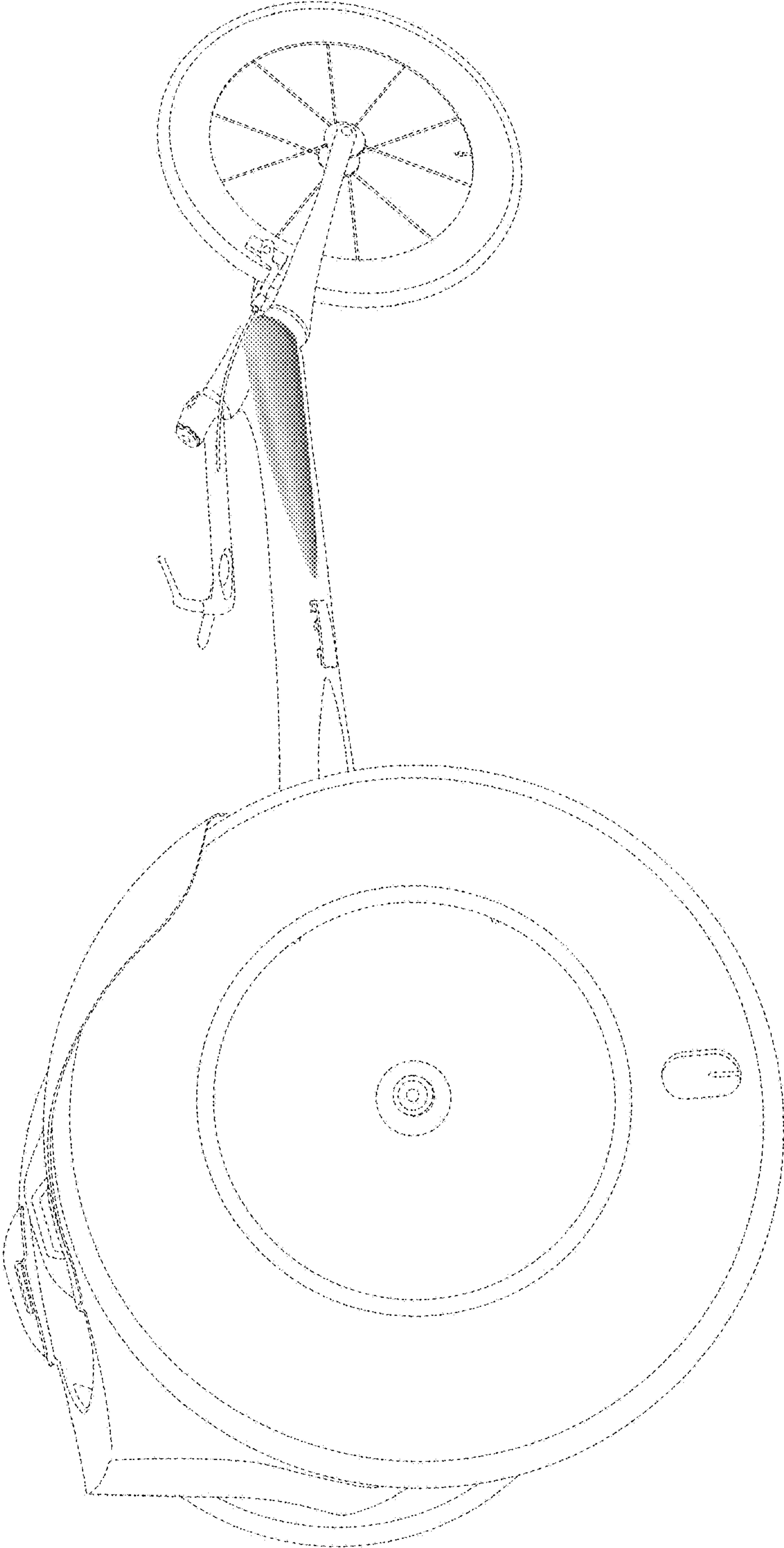

Fig. 3

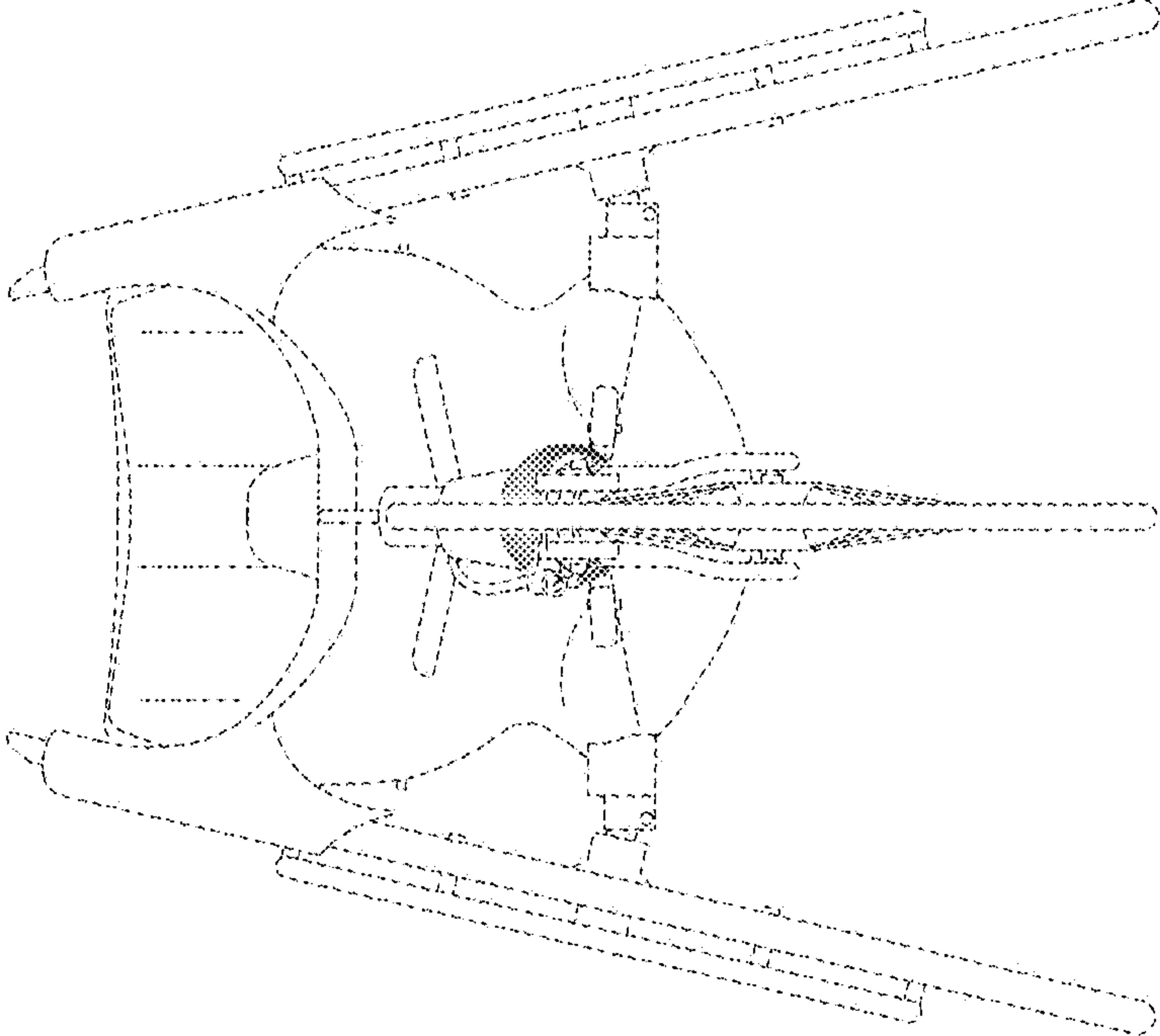

Fig.4

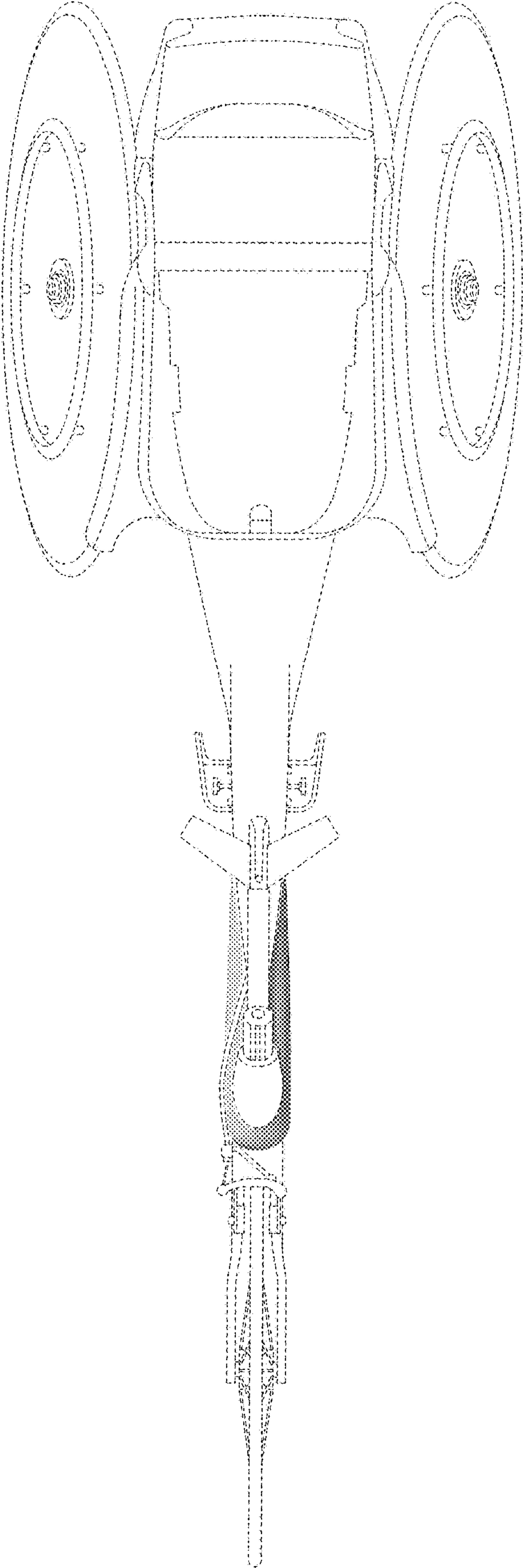

Fig. 5

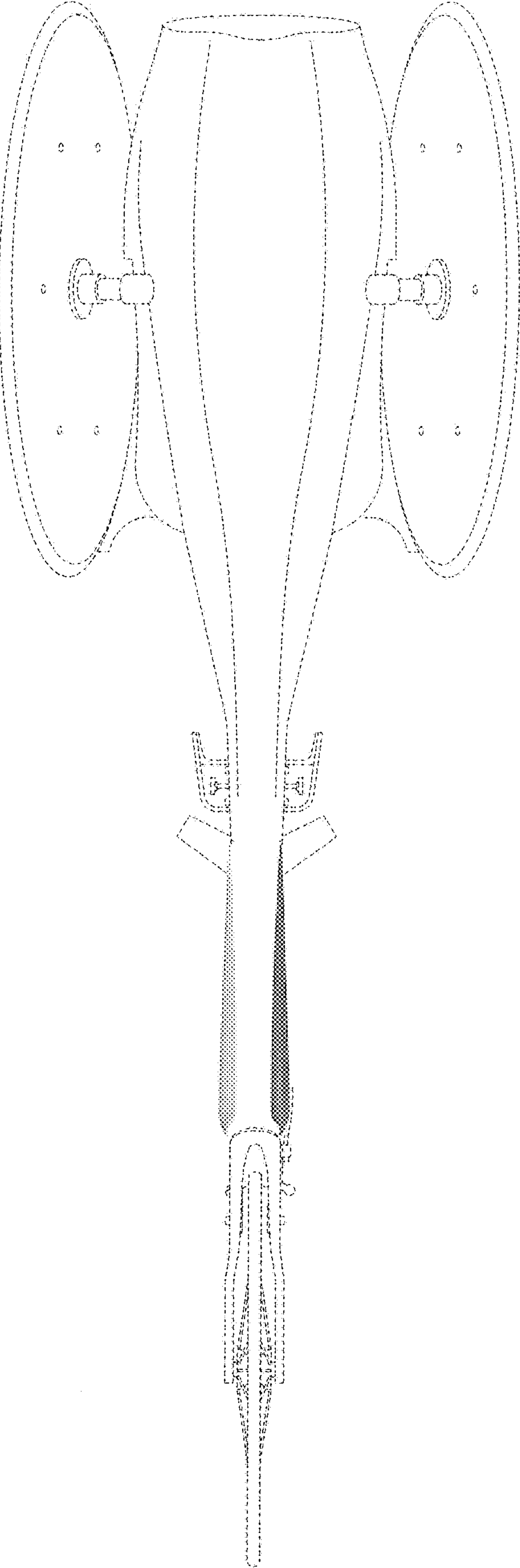

Fig. 6

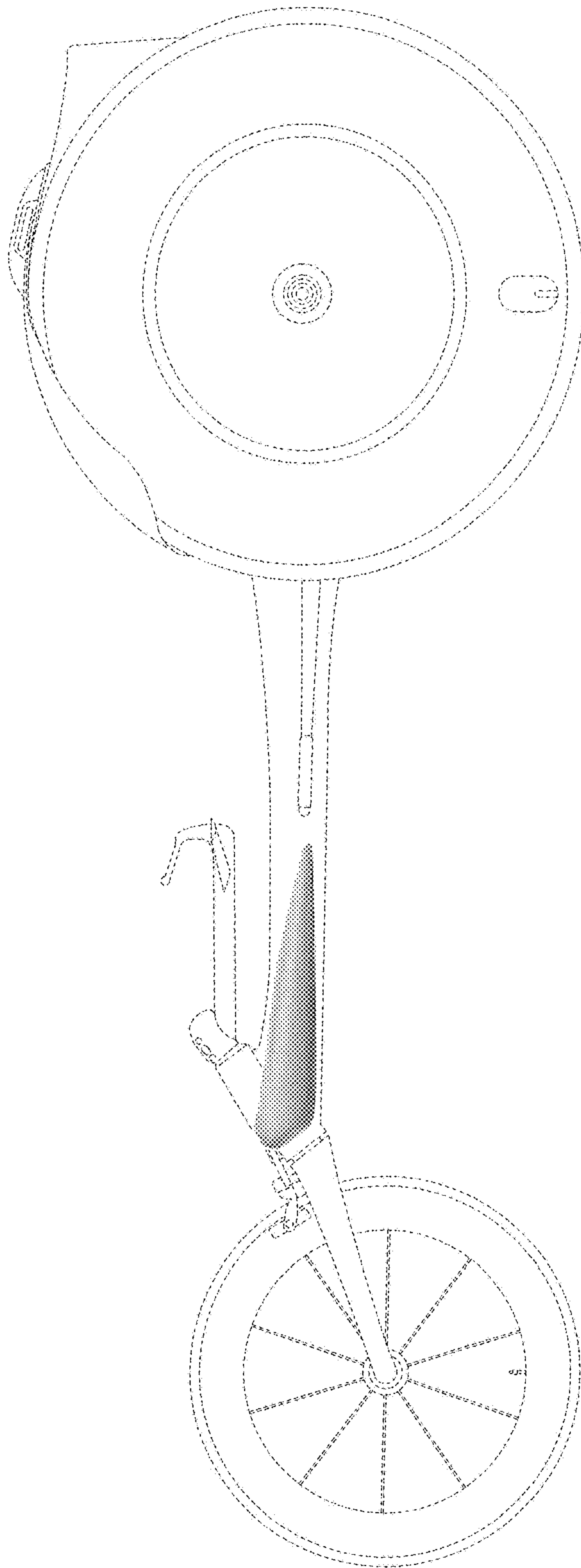

Fig. 7

Fig. 8

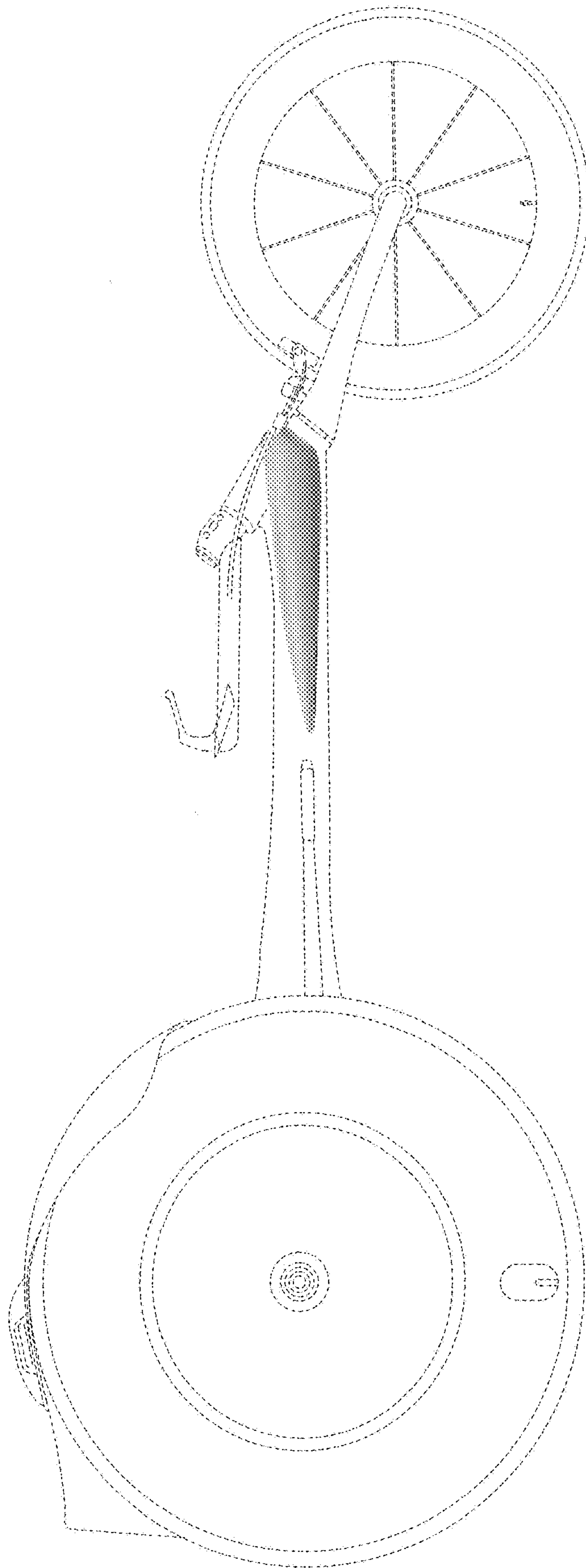

Fig. 9

