



US00D947135S

(12) **United States Design Patent** (10) **Patent No.:** **US D947,135 S**
Roys (45) **Date of Patent:** **** Mar. 29, 2022**

(54) **FIELD SENSITIVE PROXIMITY SWITCH HOUSING**

FOREIGN PATENT DOCUMENTS

(71) Applicant: **Curtis Alan Roys**, Fredericksburg, TX (US)

JP 09009477 A * 1/1997

* cited by examiner

(72) Inventor: **Curtis Alan Roys**, Fredericksburg, TX (US)

Primary Examiner — Shawn T Gingrich

(74) *Attorney, Agent, or Firm* — Scheinberg & Associates, PC; Michael Scheinberg

(**) Term: **15 Years**

(57) **CLAIM**

I claim the ornamental design for a field sensitive proximity switch housing, as shown and described.

(21) Appl. No.: **29/754,118**

DESCRIPTION

(22) Filed: **Oct. 6, 2020**

(51) **LOC (13) Cl.** **13-03**

FIG. 1 is an isometric view of a first embodiment of a field sensitive proximity switch housing in accordance with my new design;

(52) **U.S. Cl.**

USPC **D13/158**

FIG. 2 is a front elevation of the field sensitive proximity switch housing shown in FIG. 1;

(58) **Field of Classification Search**

USPC D13/118–120, 123, 151, 154, 156, 158, D13/159, 173, 177, 184, 199

FIG. 3 is a right side elevation view of the field sensitive proximity switch housing shown in FIG. 1;

CPC G01R 27/04; G01R 27/26; H01H 36/00; H01R 9/05; H01R 13/00; H01R 13/52;

FIG. 4 is a top plan view of the field sensitive proximity switch housing shown in FIG. 1;

H01R 13/658; H01R 24/00; H03K 17/96

FIG. 5 is a bottom view of the field sensitive proximity switch housing shown in FIG. 1;

See application file for complete search history.

FIG. 6 is an isometric view of a second embodiment of a field sensitive proximity switch housing in accordance with my new design;

(56) **References Cited**

U.S. PATENT DOCUMENTS

D178,775 S * 9/1956 Gombar D13/138.2

FIG. 7 is a front elevation of the field sensitive proximity switch housing shown in FIG. 6;

D244,297 S * 5/1977 Stropkay D13/138.1

FIG. 8 is a right side elevation view of the field sensitive proximity switch housing shown in FIG. 6;

D487,015 S * 2/2004 Kal D16/339

FIG. 9 is a top plan view of the field sensitive proximity switch housing shown in FIG. 6; and,

D495,662 S * 9/2004 Chawgo D13/151

FIG. 10 is a bottom view of the field sensitive proximity switch housing shown in FIG. 6.

D512,492 S * 12/2005 Lipscomb D23/259

The front elevation is the same as the rear elevation for both embodiments. The left side elevation is the same as the right side elevation in both embodiments.

D534,129 S * 12/2006 Park D13/151

D546,769 S * 7/2007 Sengupta D13/133

D586,435 S * 2/2009 Reckseen D23/266

D614,584 S * 4/2010 Neitzel D13/156

D662,063 S * 6/2012 Eriksen D13/151

D833,585 S * 11/2018 Khubani D23/262

2005/0191903 A1 * 9/2005 Goodwin H01R 13/512

439/578

2019/0207333 A1 * 7/2019 Zhang H01R 12/52

1 Claim, 4 Drawing Sheets

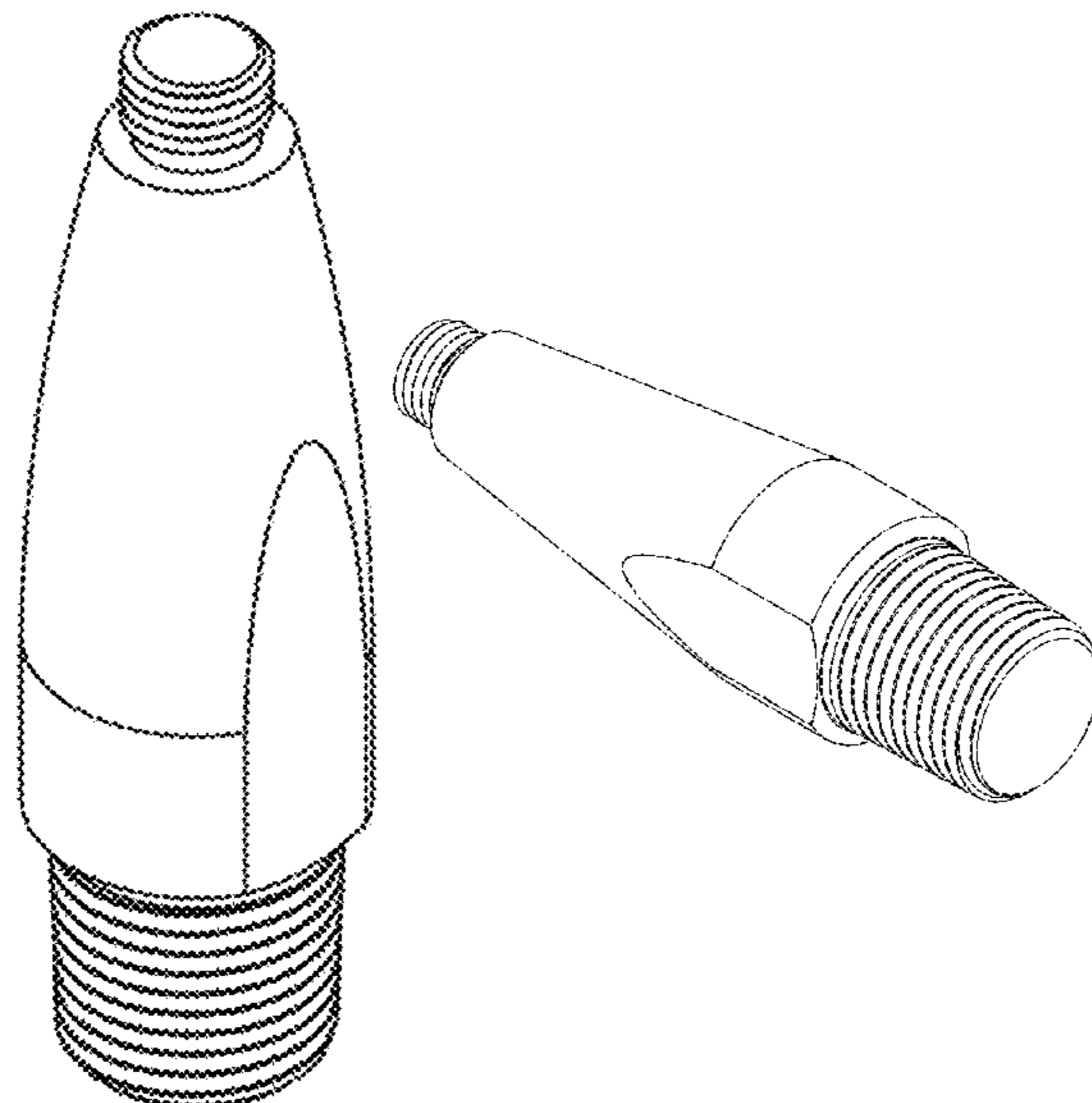

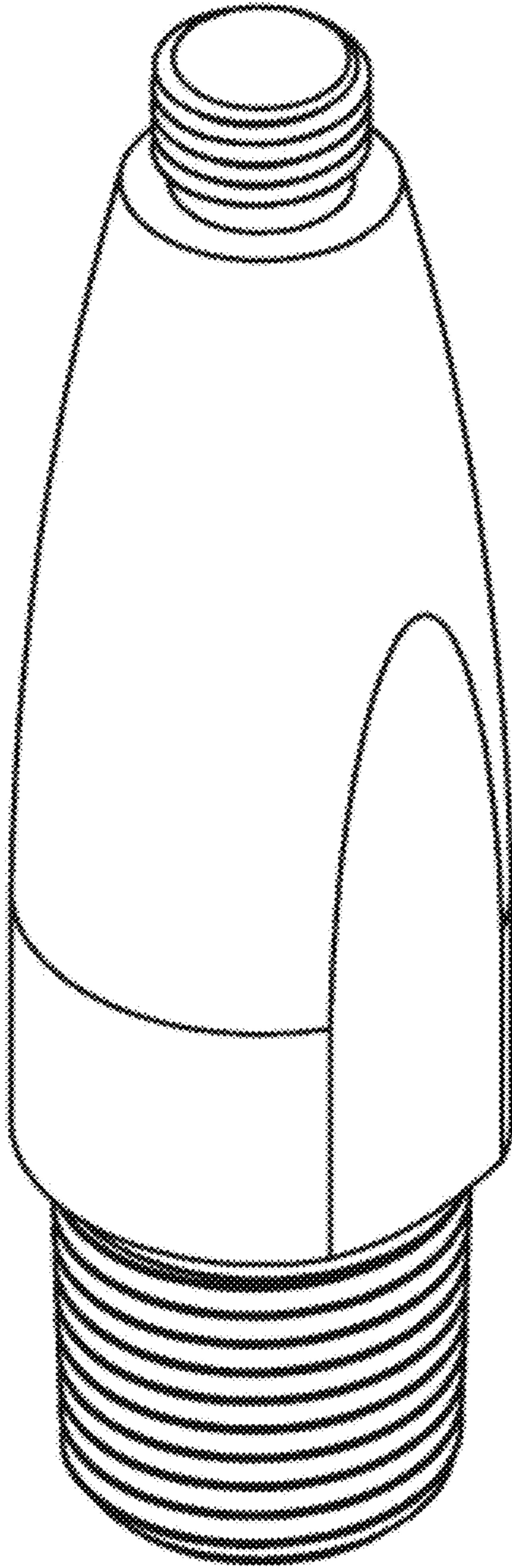

FIG. 1

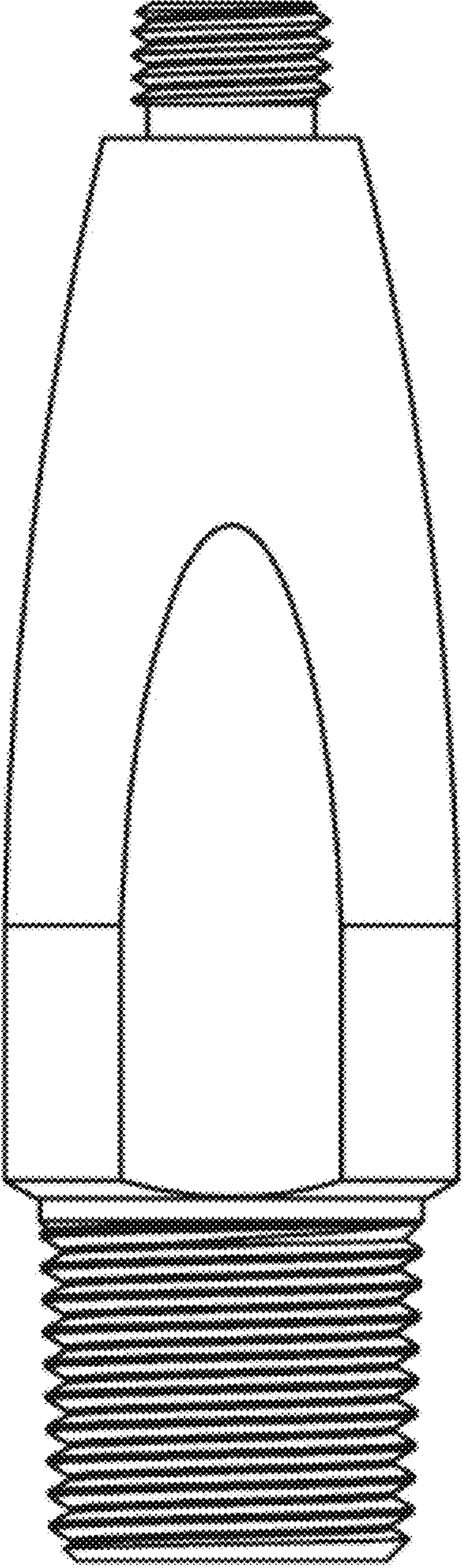

FIG. 2

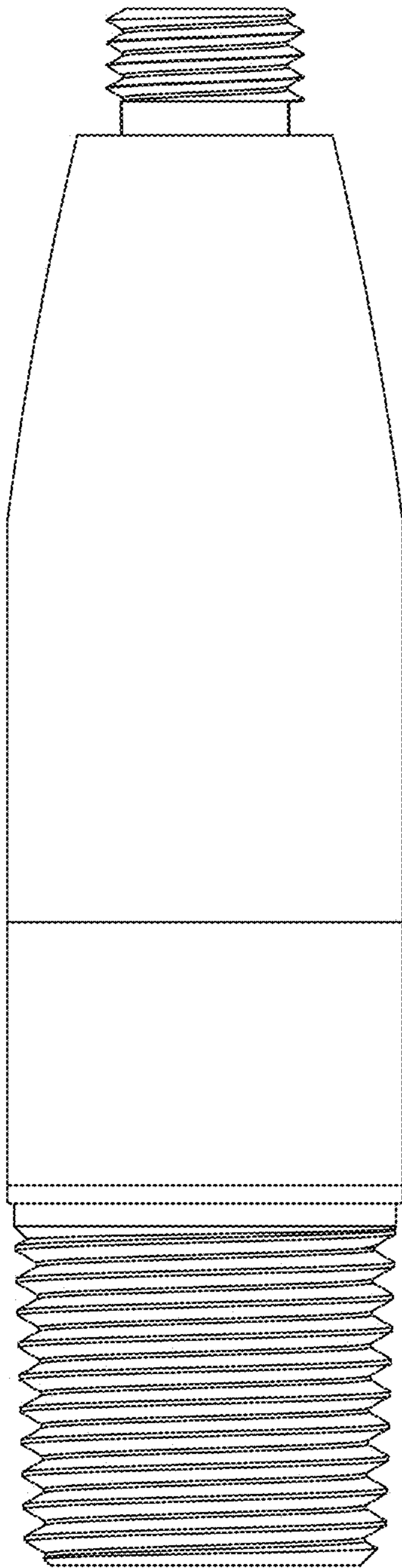

FIG. 3

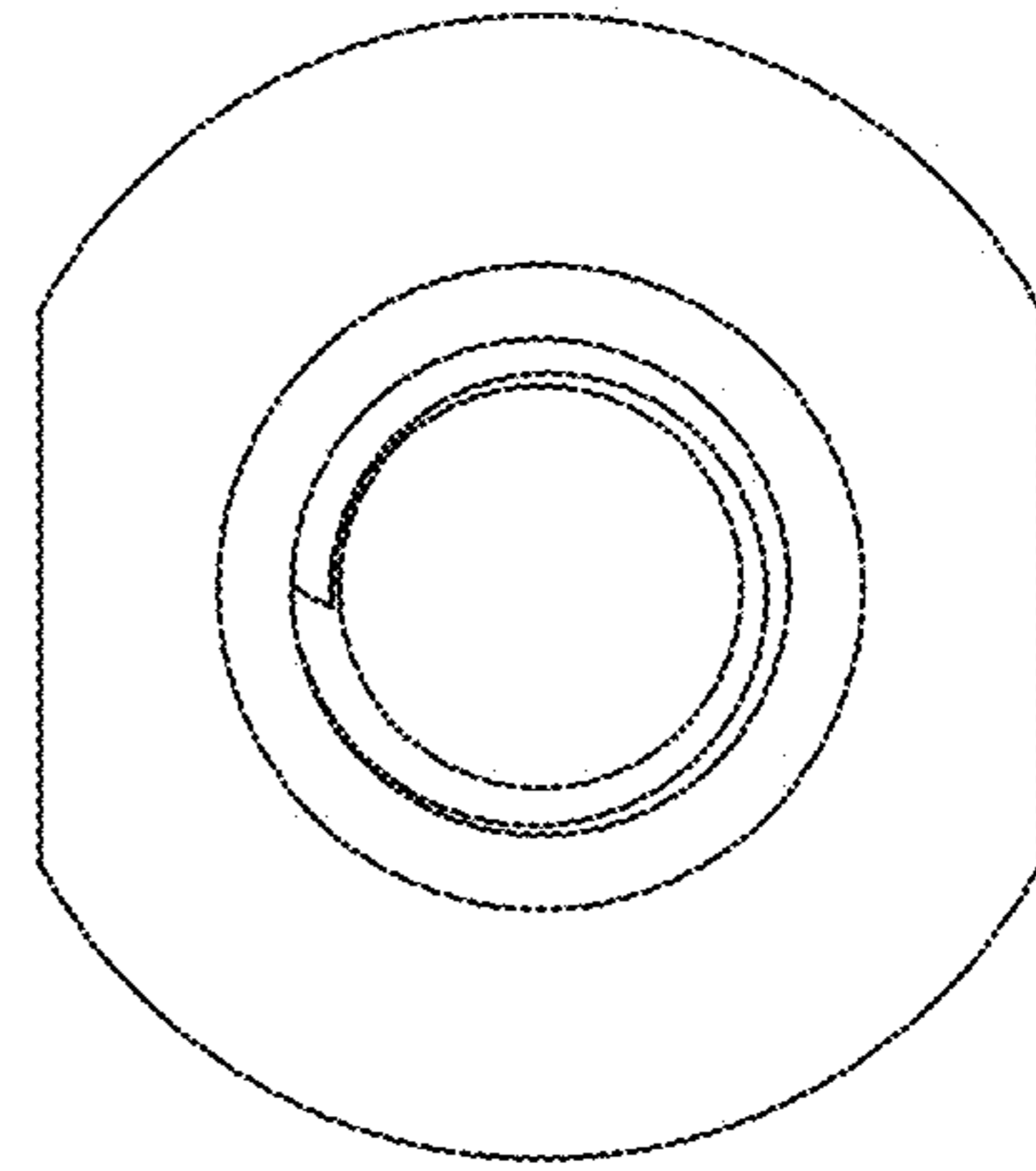

FIG. 4

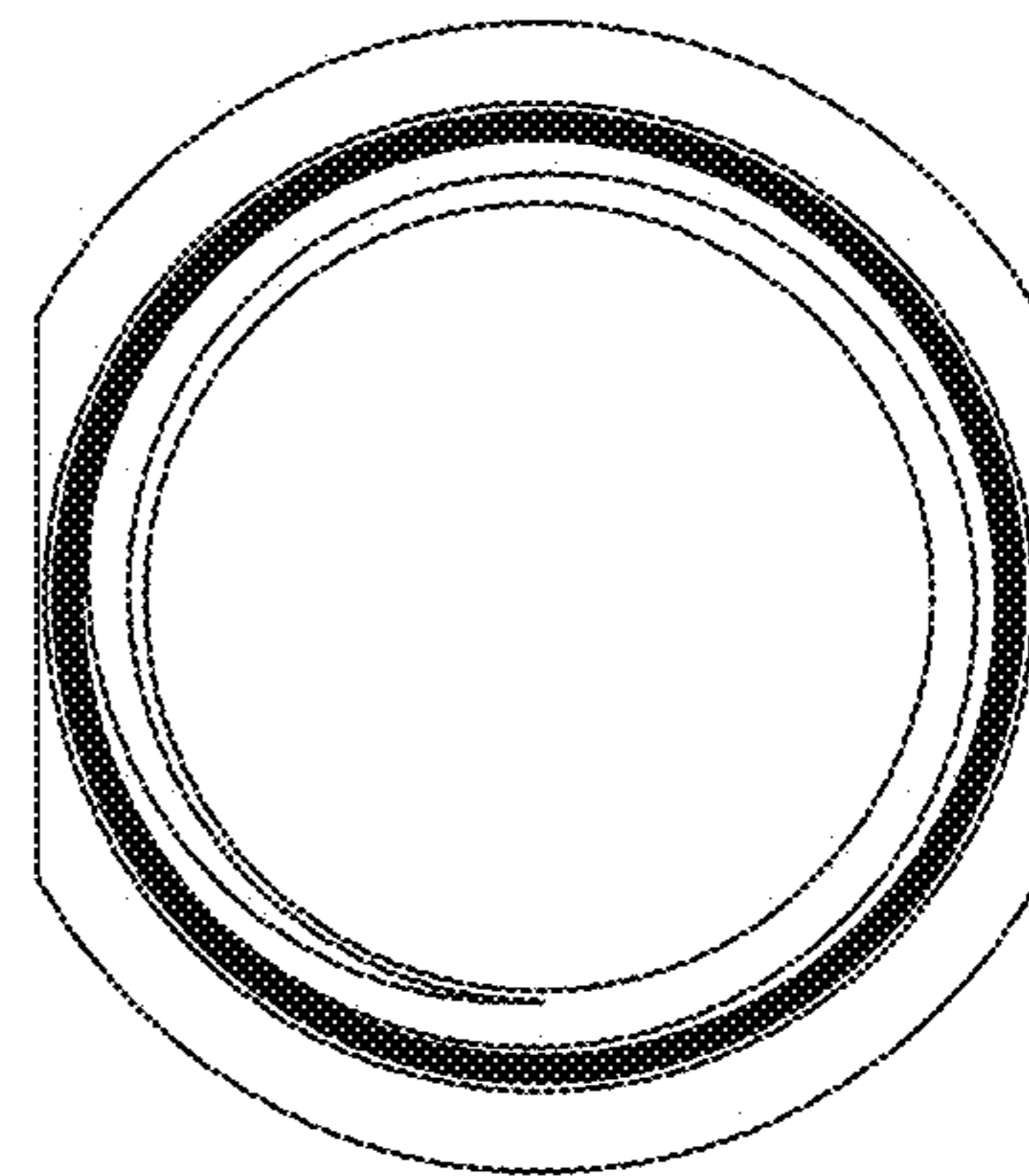

FIG. 5

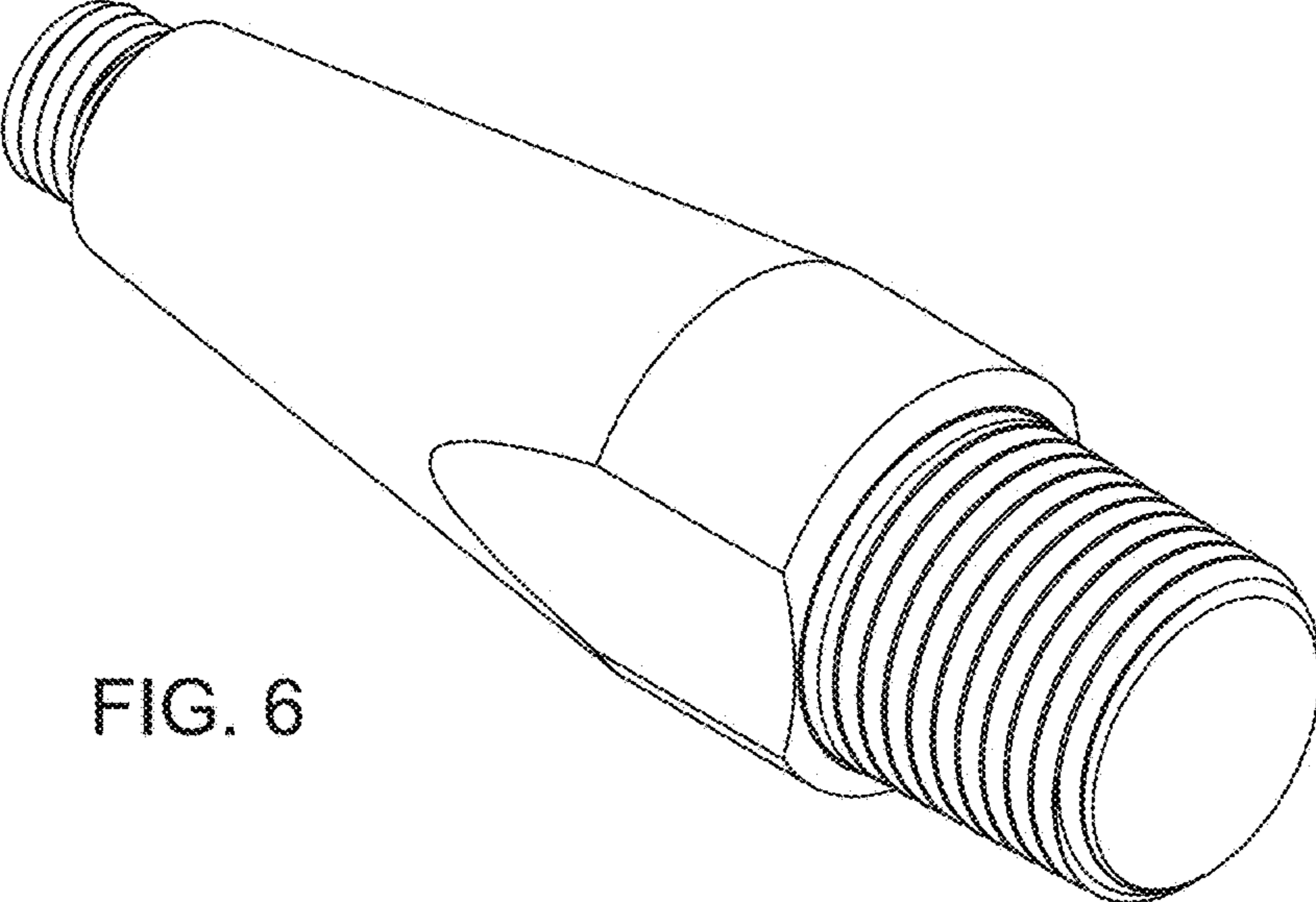

FIG. 6

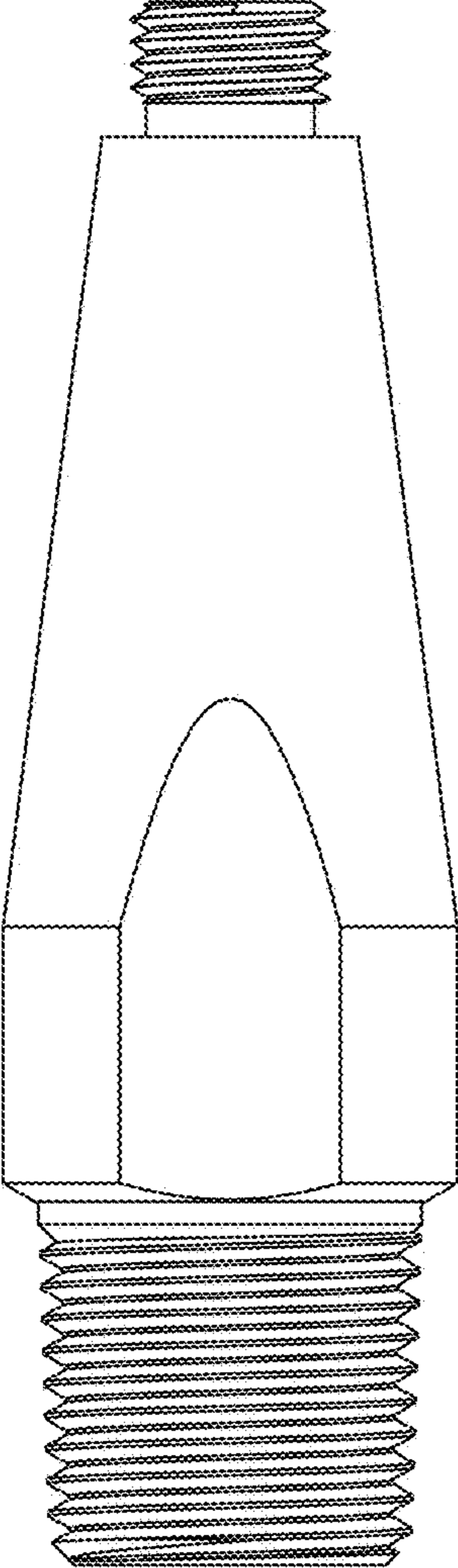

FIG. 8

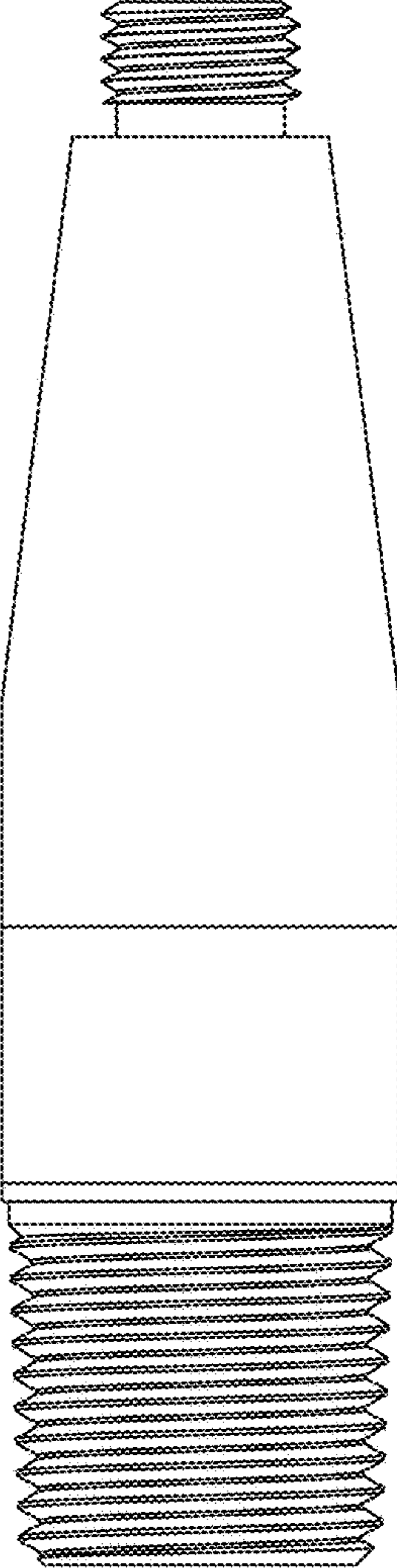

FIG. 7

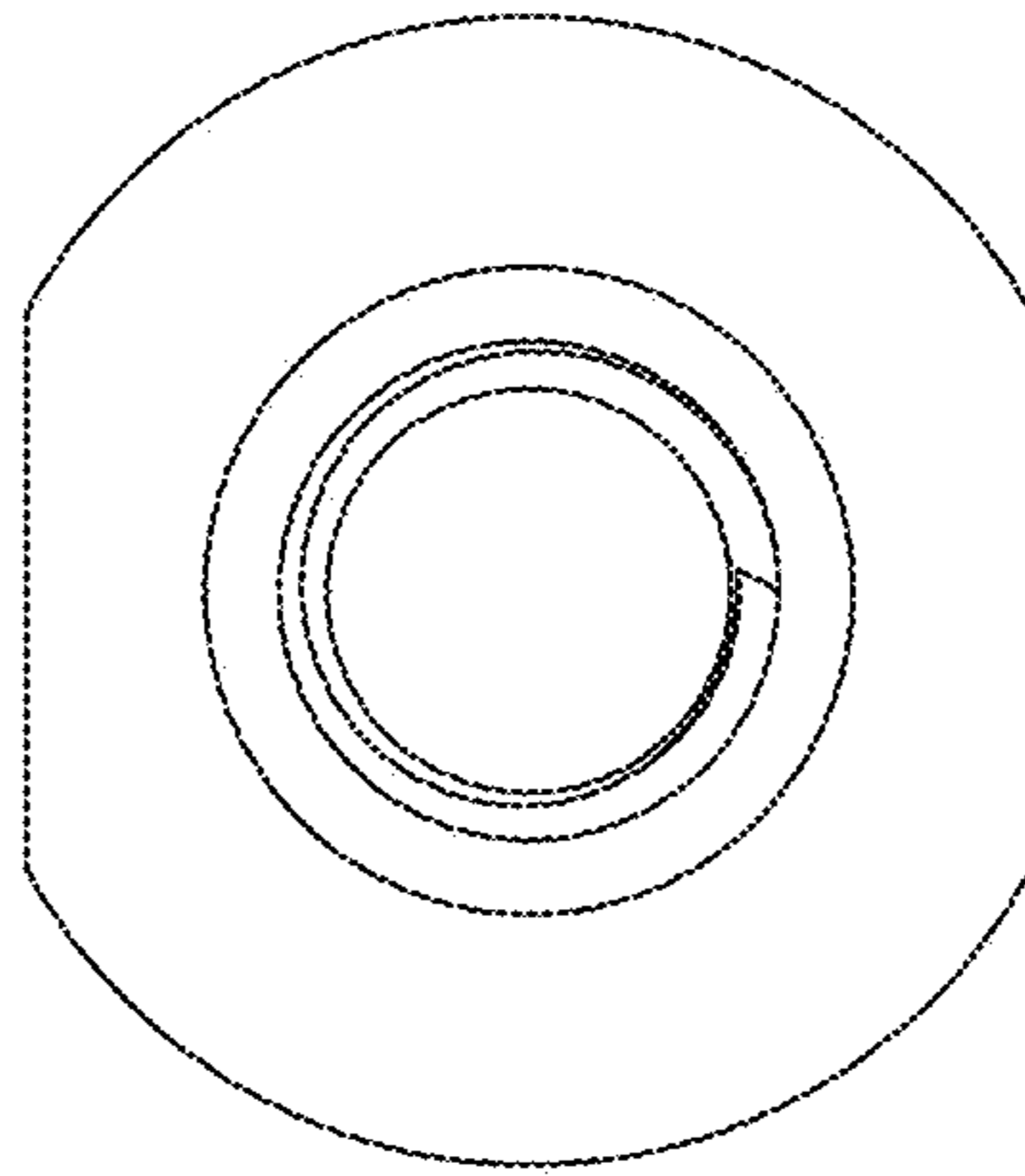

FIG. 9

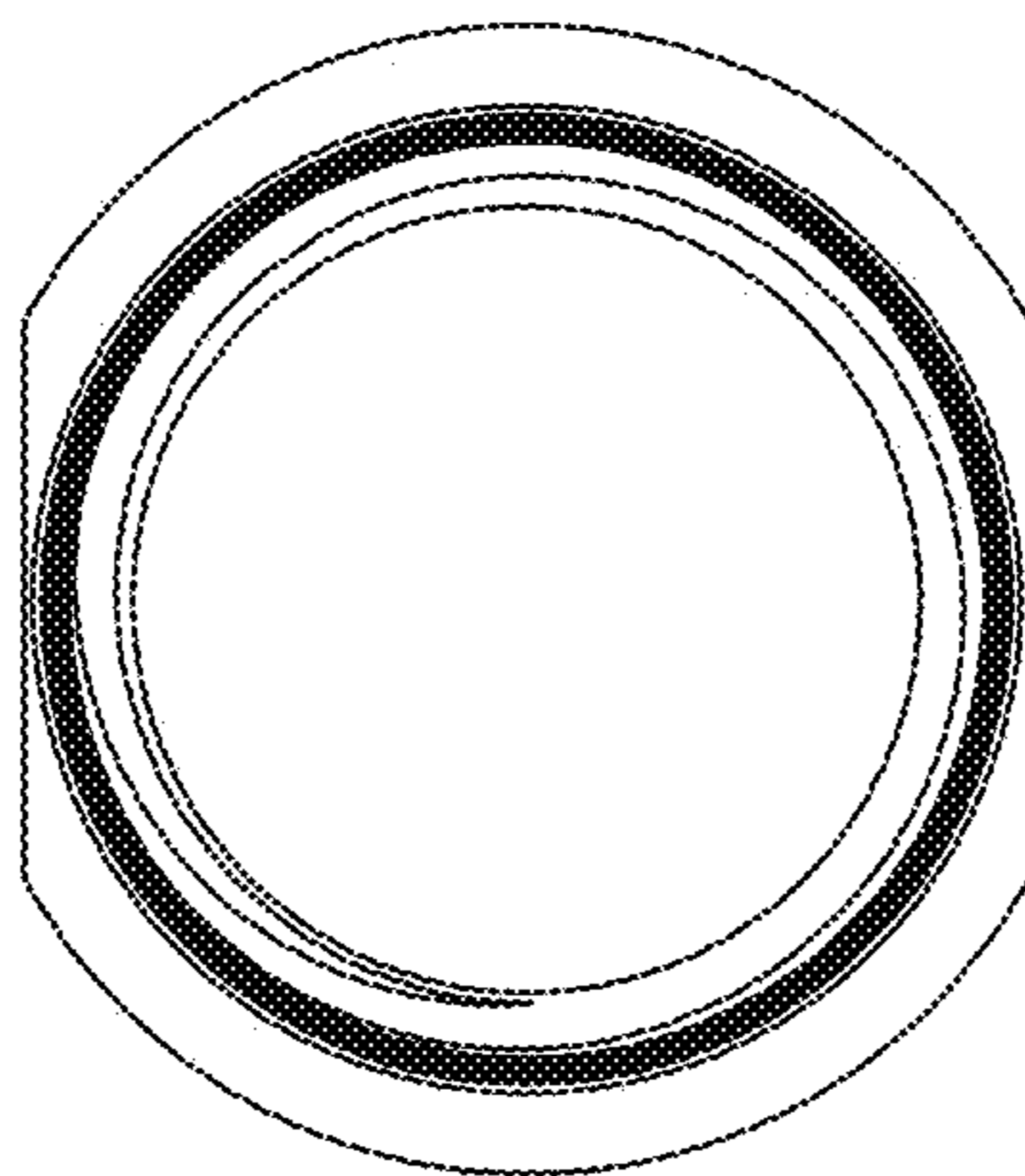

FIG. 10