



US00D946127S

(12) **United States Design Patent**
Comalander

(10) **Patent No.:** **US D946,127 S**

(45) **Date of Patent:** **** Mar. 15, 2022**

(54) **PLATFORM AND INSERT SET FOR A PIPE SUPPORT SYSTEM**

(71) Applicant: **Comalander Fabrication and Services, LLC**, Beaumont, TX (US)

(72) Inventor: **Christopher R. Comalander**, Beaumont, TX (US)

(73) Assignee: **Comalander Fabrication and Services, LLC**, Beaumont, TX (US)

(**) Term: **15 Years**

(21) Appl. No.: **29/695,338**

(22) Filed: **Jun. 18, 2019**

(51) **LOC (13) Cl.** **23-01**

(52) **U.S. Cl.**
USPC **D23/259**; D8/354

(58) **Field of Classification Search**
USPC D23/259, 261–262, 264–265; 285/19, 285/189, 200, 56, 58, 61; 248/49, 678; D8/354, 380

(Continued)

(56) **References Cited**

U.S. PATENT DOCUMENTS

2,684,222 A * 7/1954 Miller F16L 3/1218
248/49
4,744,535 A * 5/1988 Patenaude F16L 3/1207
248/62

(Continued)

OTHER PUBLICATIONS

Screen Shot of Adjustable Pipe Saddle Support, Kit; Accessed Aug. 12, 2019; Date of publication unknown; <https://www.empireindustries.com>; pp. 2.

(Continued)

Primary Examiner — Amy C Wierenga

(74) *Attorney, Agent, or Firm* — Peter L. Brewer; Thrive IP

(57) **CLAIM**

The ornamental design for a platform and insert set for a pipe support system, as shown and described.

DESCRIPTION

FIG. 1 is a first perspective view of a platform and insert set for a pipe support system that together may be used as part of a pipe support system, showing my new design; FIG. 2 is a second perspective view of the platform and insert set for a pipe support system of FIG. 1, with the platform and the insert in exploded-apart relation . FIG. 3 is a front elevation view of the platform and insert set for a pipe support system of FIG. 1; FIG. 4 is a rear elevation view thereof, which is a mirror image of FIG. 3; FIG. 5 is a right side elevation view thereof; FIG. 6 is a left side elevation view thereof, which is a mirror image of FIG. 5; FIG. 7 is a top plan view thereof; FIG. 8 is a bottom view thereof; FIG. 9 is a perspective view of the platform of FIG. 1, shown without the insert; FIG. 10 is a front elevation view of the platform of FIG. 1; FIG. 11 is a rear elevation view of the platform of FIG. 9, which is a mirror image of FIG. 10; FIG. 12 is a right side elevation view of the platform of FIG. 9; FIG. 13 is a left side elevation view of the platform of FIG. 9, which is a mirror image of FIG. 12; FIG. 14 is a top elevation view of the platform of FIG. 9; FIG. 15 is a bottom view of the platform of FIG. 9; FIG. 16 is a perspective view of the insert of FIG. 1, shown without the platform; FIG. 17 is a front elevation view of the insert of FIG. 16; FIG. 18 is a rear elevation view of the insert of FIG. 16, which is a mirror image of FIG. 17; FIG. 19 is a right side elevation view of the insert of FIG. 16; FIG. 20 is a left side elevation view of the insert of FIG. 16, which is a mirror image of FIG. 19;

(Continued)

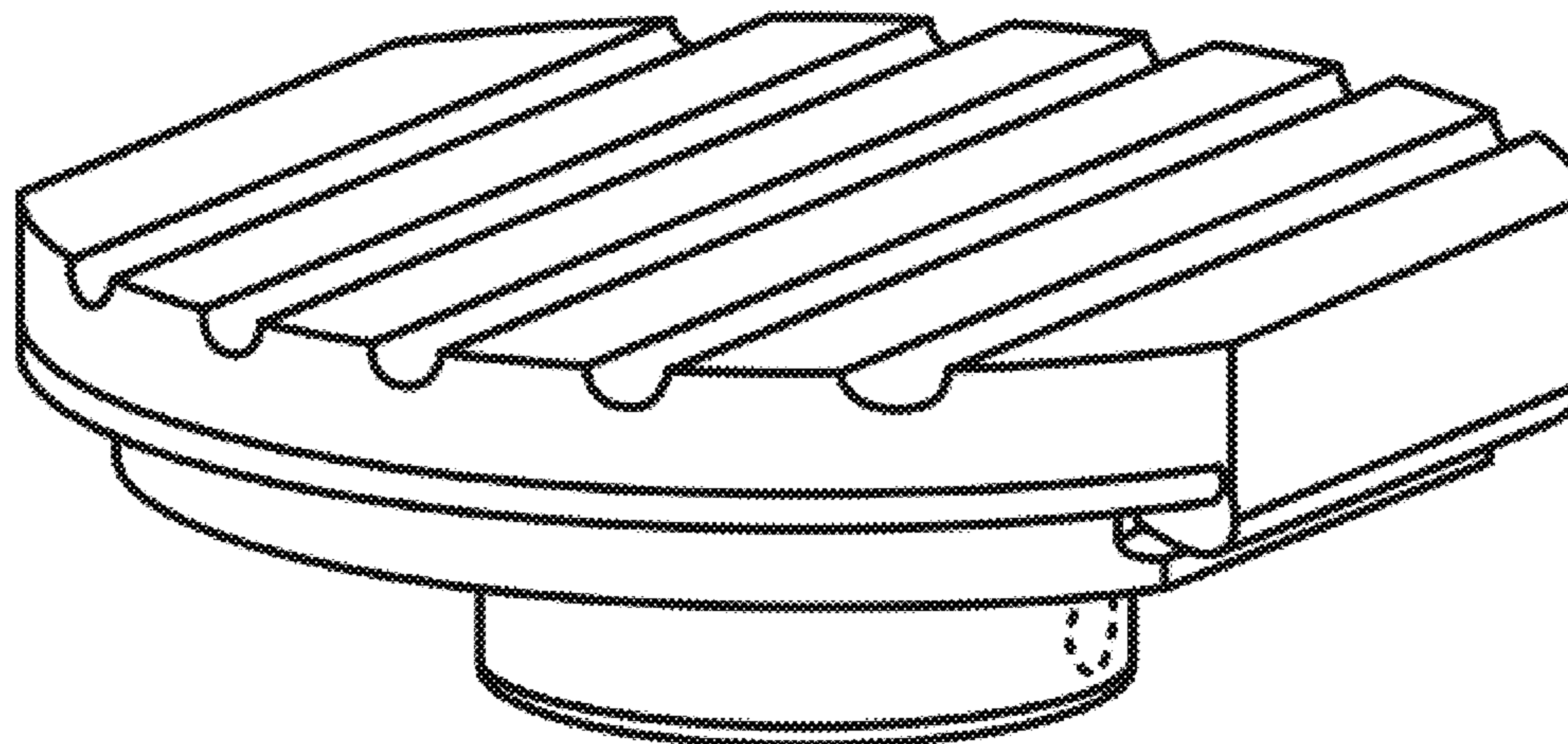

FIG. 21 is a top plan view of the insert of FIG. 16; and, FIG. 22 is a bottom view of the insert of FIG. 16. The broken lines in the drawings depict portions of the platform that form no part of the claimed designs.

1 Claim, 7 Drawing Sheets

(58) **Field of Classification Search**

CPC ... F16L 27/053; F16L 3/24; F16L 1/06; F16L 57/02; F16K 27/00
See application file for complete search history.

(56) **References Cited**

U.S. PATENT DOCUMENTS

4,789,189	A	12/1988	Robertson	
5,020,934	A *	6/1991	Floren	E03B 9/02 403/2
5,110,073	A *	5/1992	Schoenky	F16L 3/02 248/49
D376,815	S *	12/1996	Vermillion	D8/354
5,806,833	A *	9/1998	Riibe	F16L 27/053 251/305
7,090,173	B2	8/2006	Lussier	
7,497,405	B2	3/2009	Huo	
8,052,110	B2 *	11/2011	Wang	E04G 25/06 248/354.3
D673,655	S *	1/2013	Morishita	D23/259

8,579,302	B2	11/2013	Kinnen et al.	
8,807,492	B2	8/2014	Lake	
9,046,197	B2	6/2015	Cousineau	
9,458,951	B2	10/2016	Haynes et al.	
9,556,688	B2	1/2017	Orgeron et al.	
9,605,773	B1 *	3/2017	Tarapchak	F16L 3/1091
9,714,726	B1 *	7/2017	Laidley	F16L 3/00
9,920,868	B2	3/2018	Sutton et al.	
10,221,968	B2	3/2019	Haynes et al.	
10,240,690	B2	3/2019	Lisin et al.	
10,245,196	B2	4/2019	Doppler et al.	
10,274,111	B2	4/2019	Breda	
2011/0192941	A1 *	8/2011	Lalancette	F16L 3/04 248/70
2014/0020174	A1 *	1/2014	Evans	F16L 27/042 4/679
2019/0285105	A1 *	9/2019	Wiley	F16B 37/0857

OTHER PUBLICATIONS

Screen Shot of Pipe Hangers and Supports Accessed Aug. 12, 2019; Date of publication unknown; <https://taylorpipesupports.ca/products/pipe-hangers-supports/pipe-saddles-stanchions.php>; pp. 3.
Screen Shot of Adjustable Deck Supports; Accessed Aug. 12, 2019; Date of publication unknown; <https://ddgro.eu/en/articles/adjustable-deck-supports-5-most-important-advantages-of-technology/>; pp. 5.
Screen Shot of Height Adjustable-Universal Mount; Accessed Aug. 12, 2019; Date of publication unknown; <https://anchoragegroup.com.au/height-adjustable-pipe-support-universal-mount/>; pp. 2.

* cited by examiner

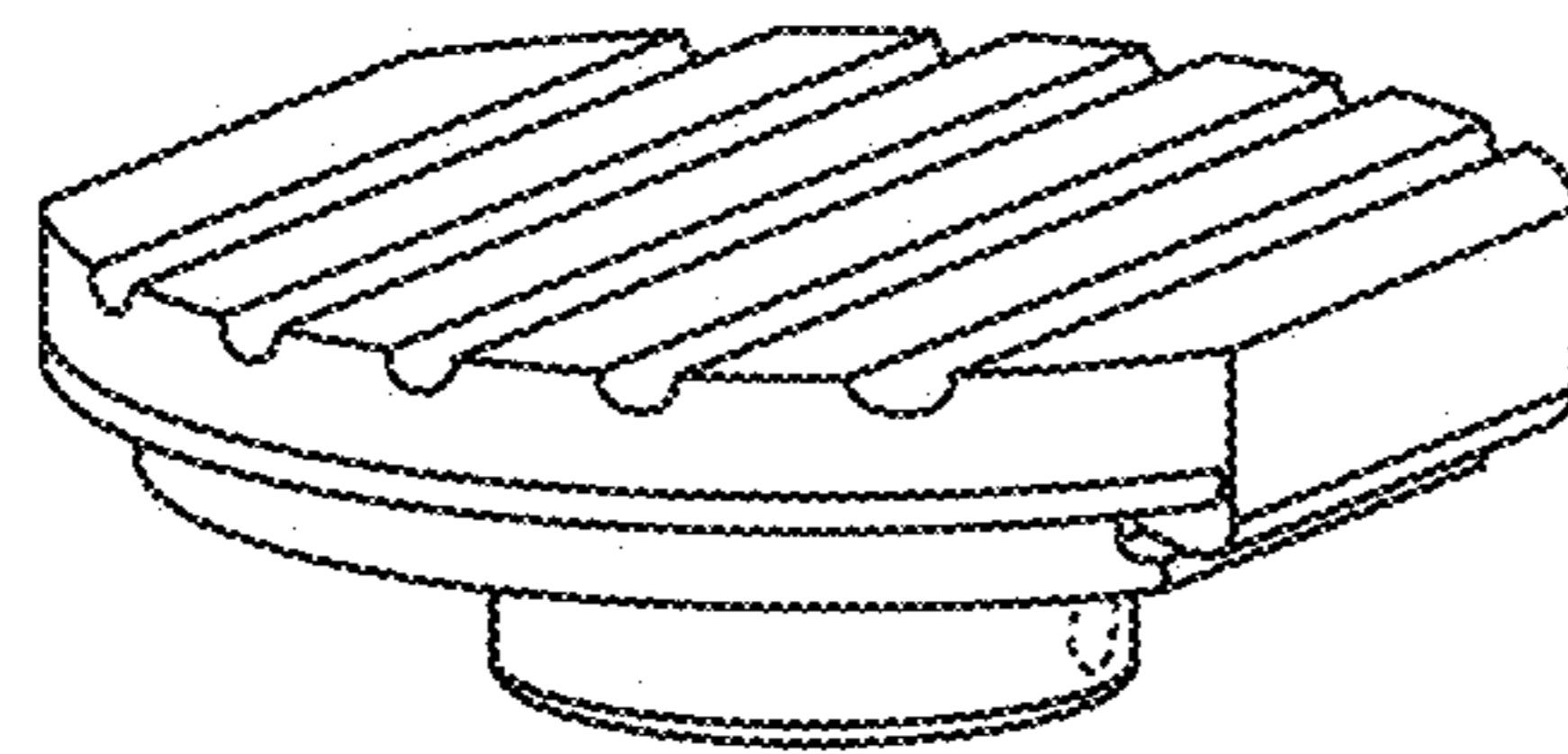

FIG. 1

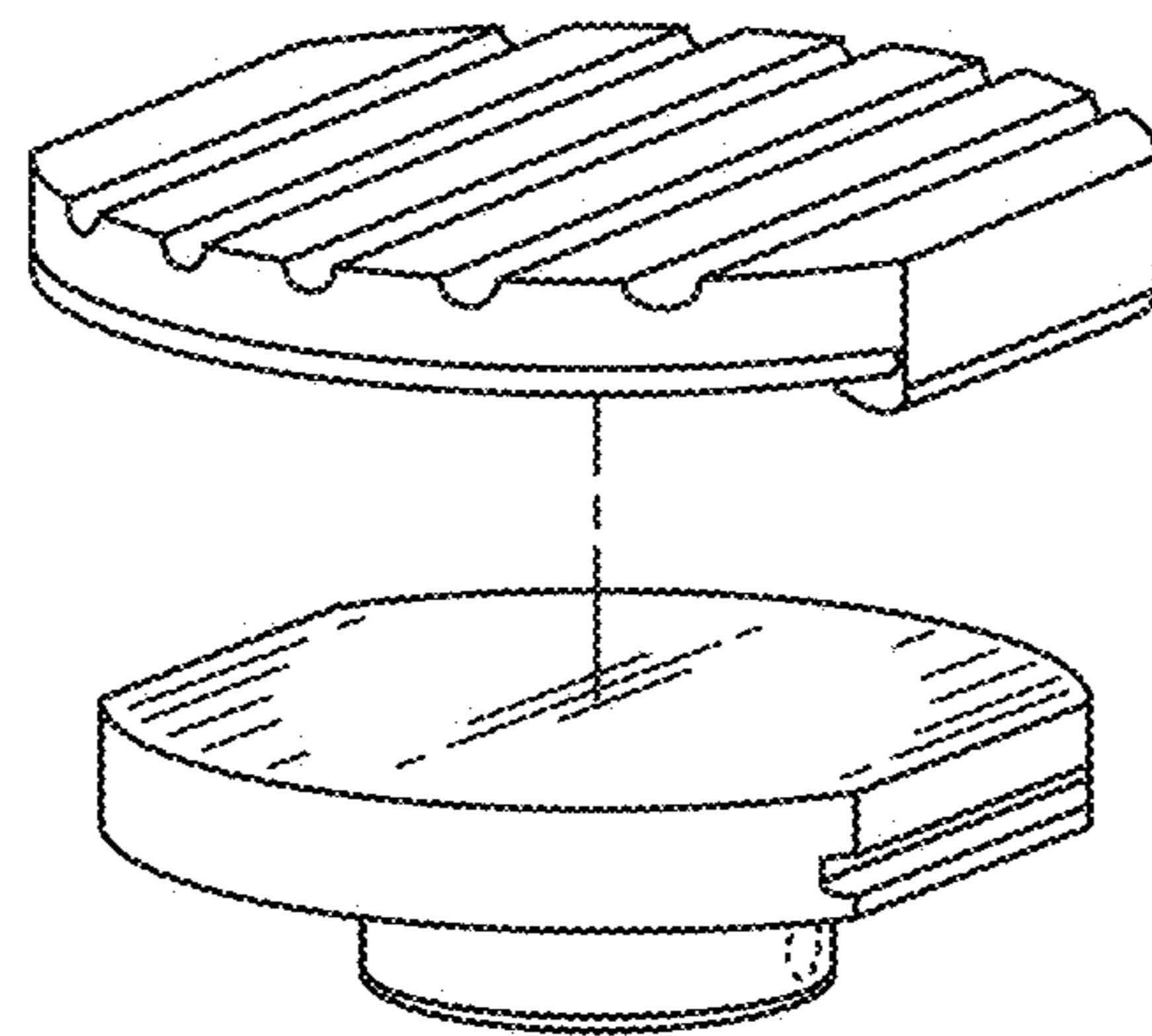

FIG. 2

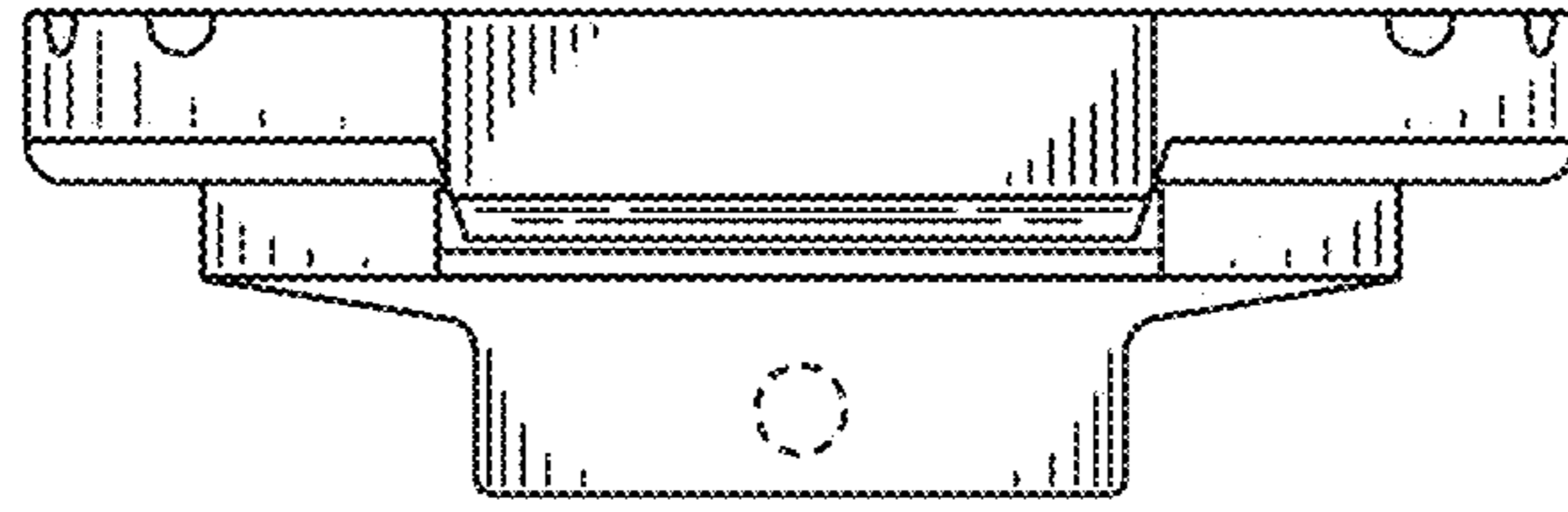

FIG. 3

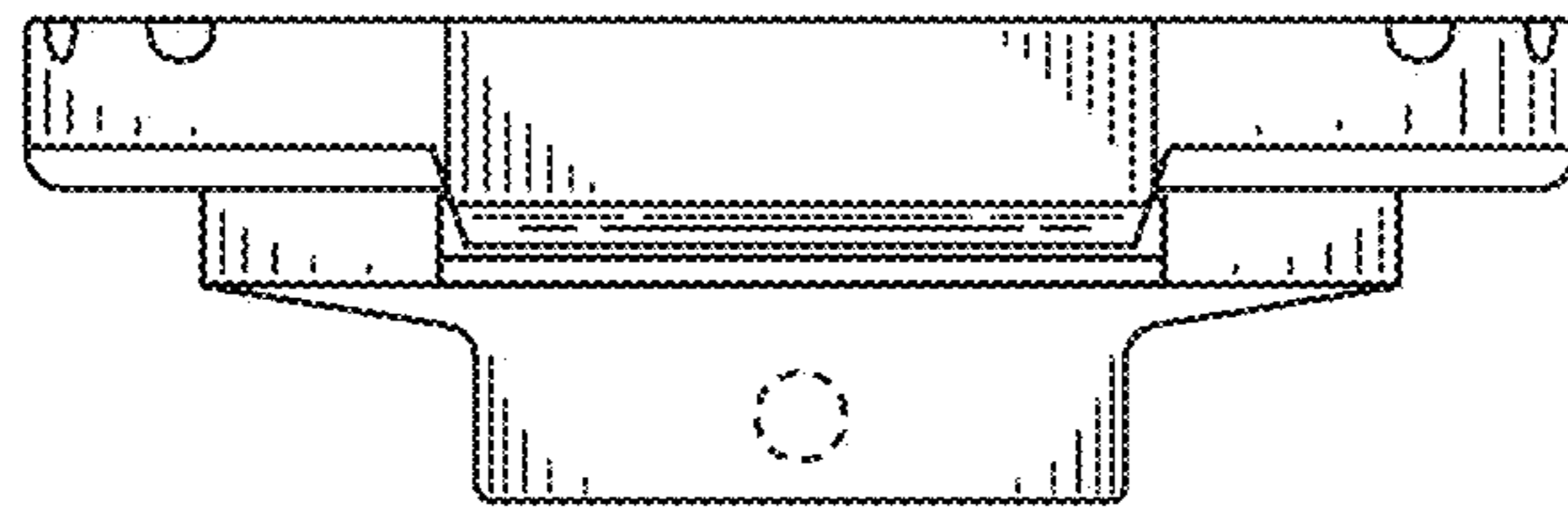

FIG. 4

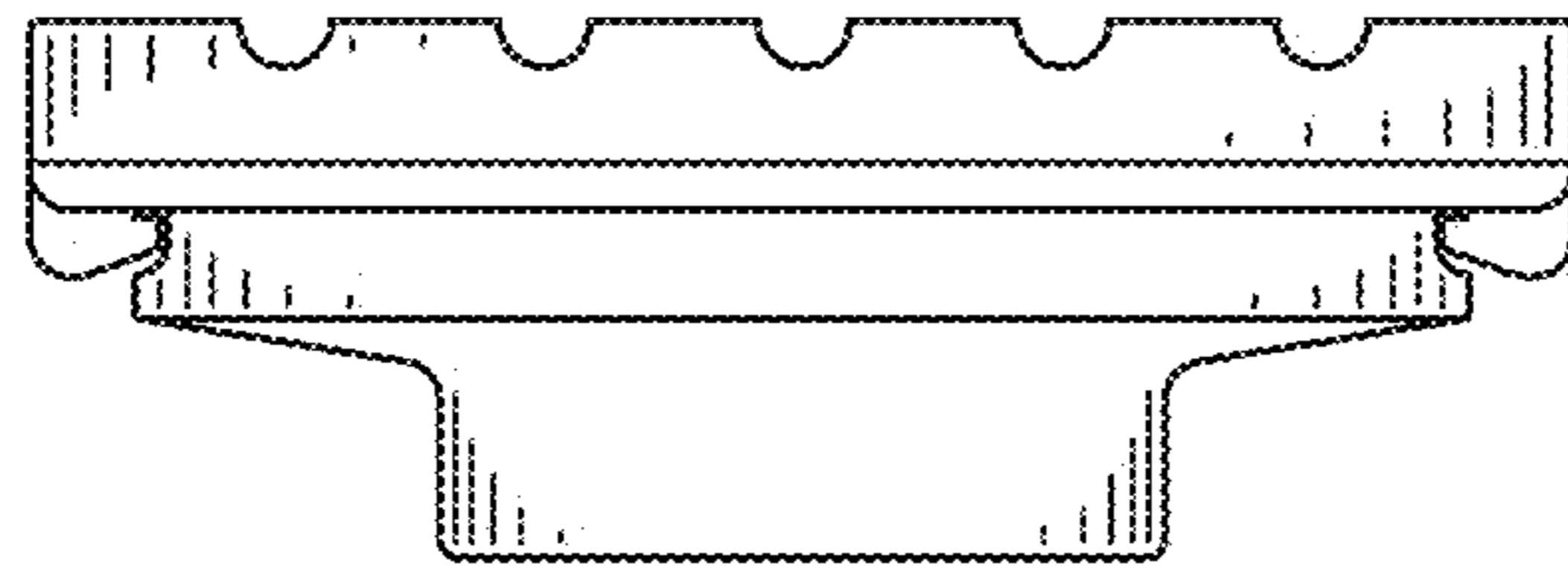

FIG. 5

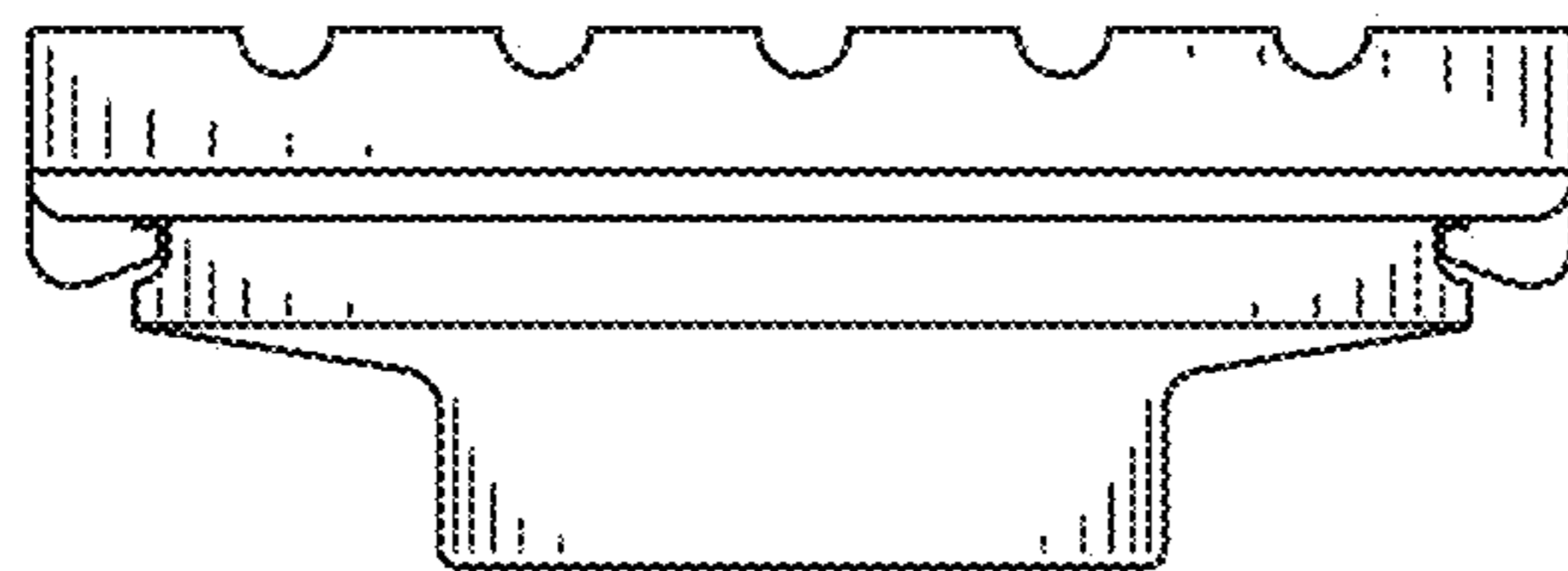

FIG. 6

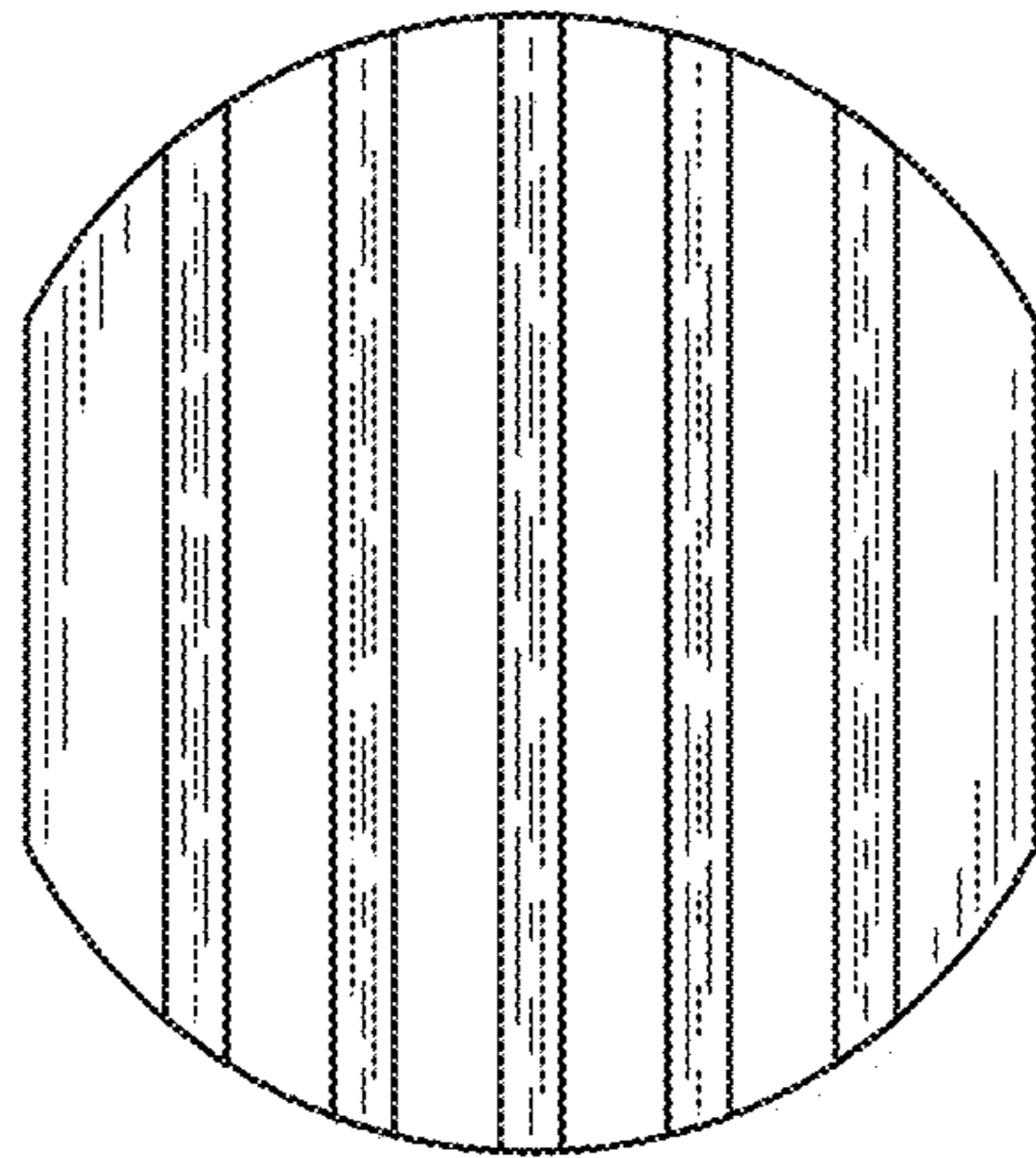

FIG. 7

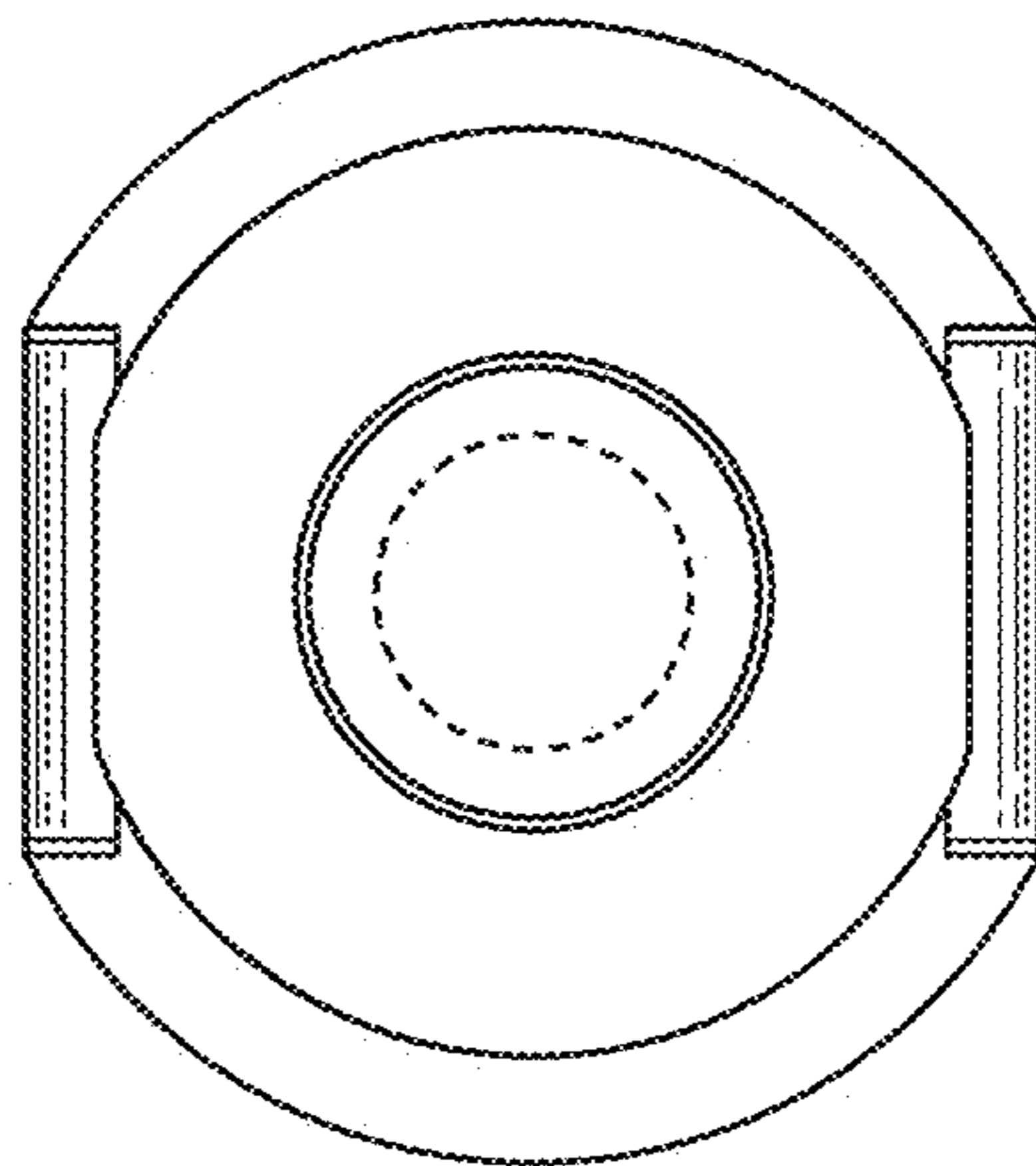

FIG. 8

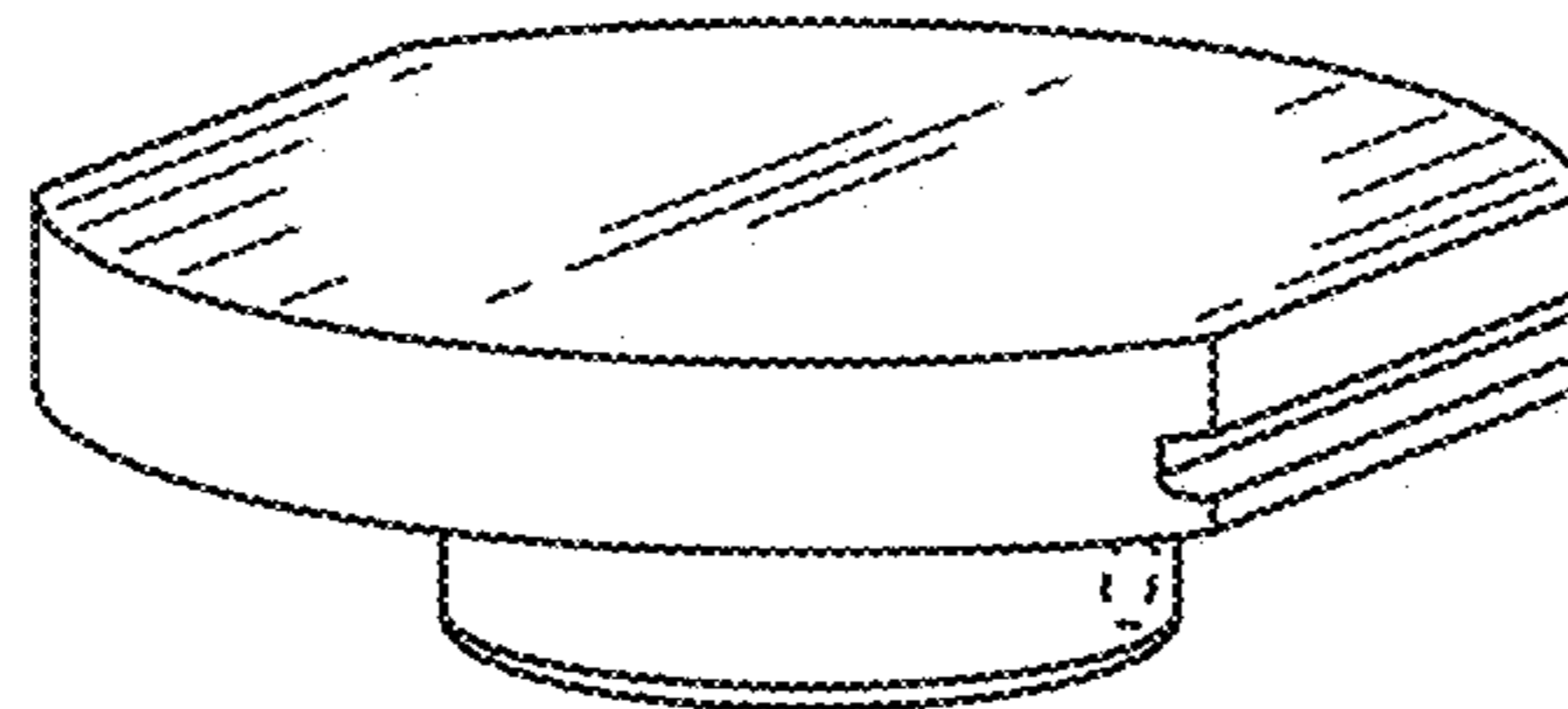

FIG. 9

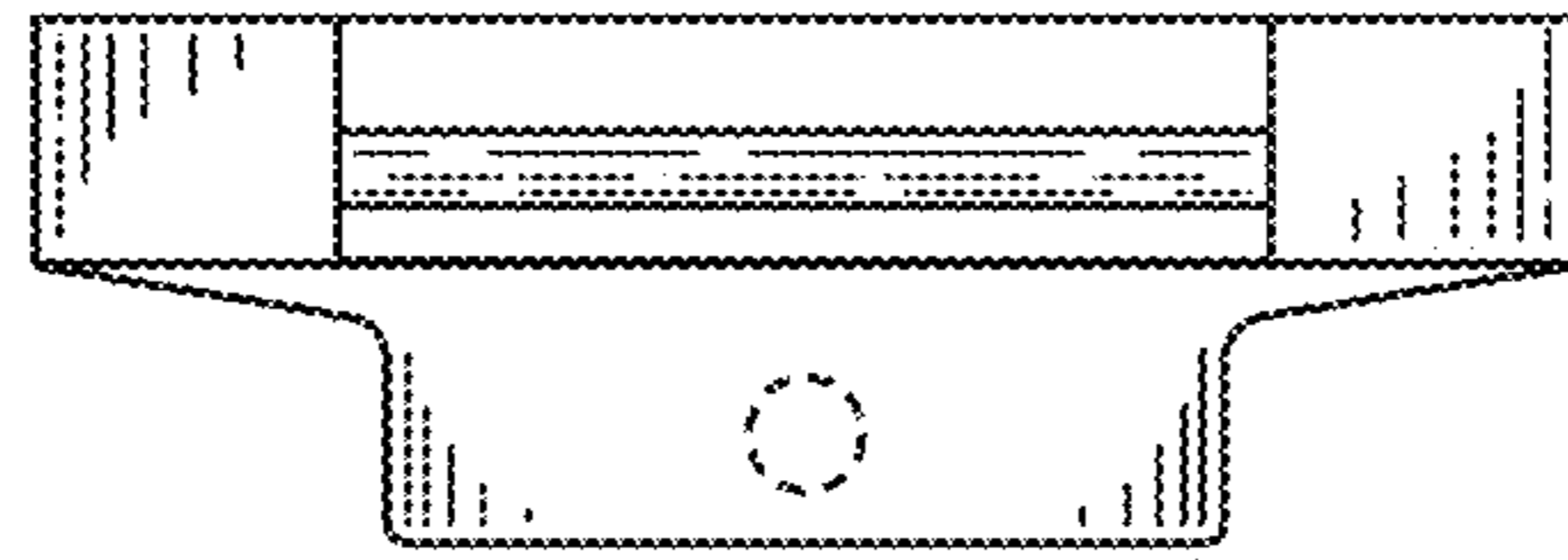

FIG. 10

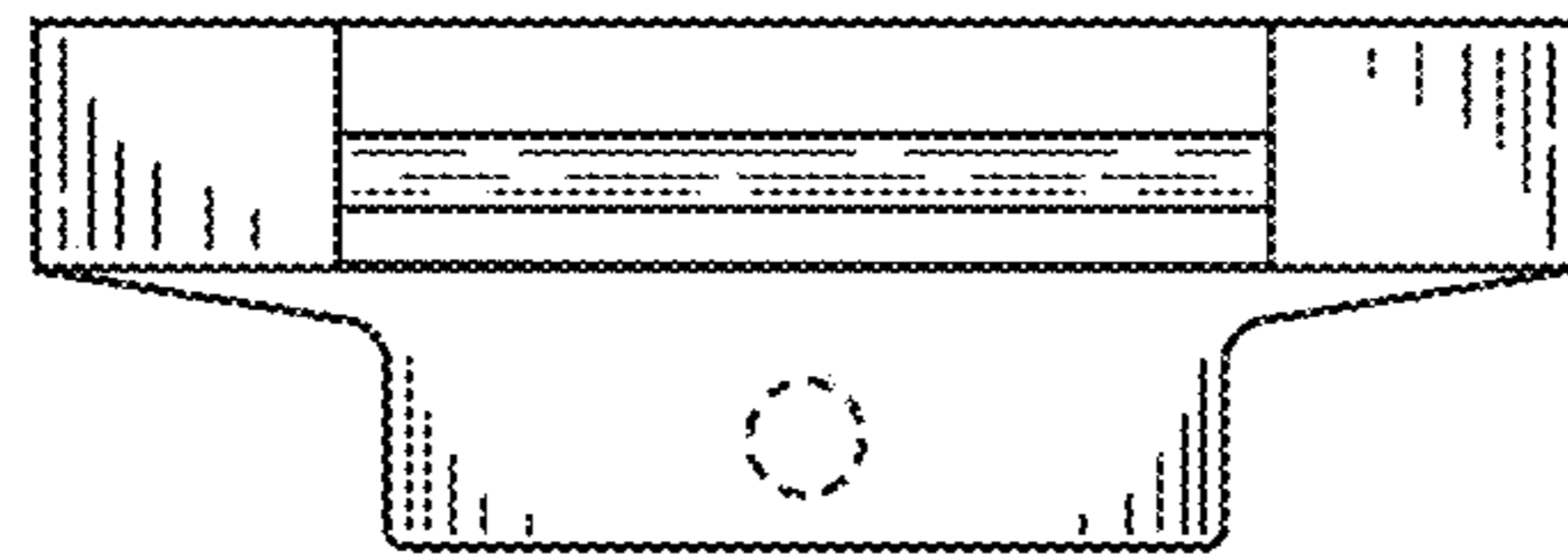

FIG. 11

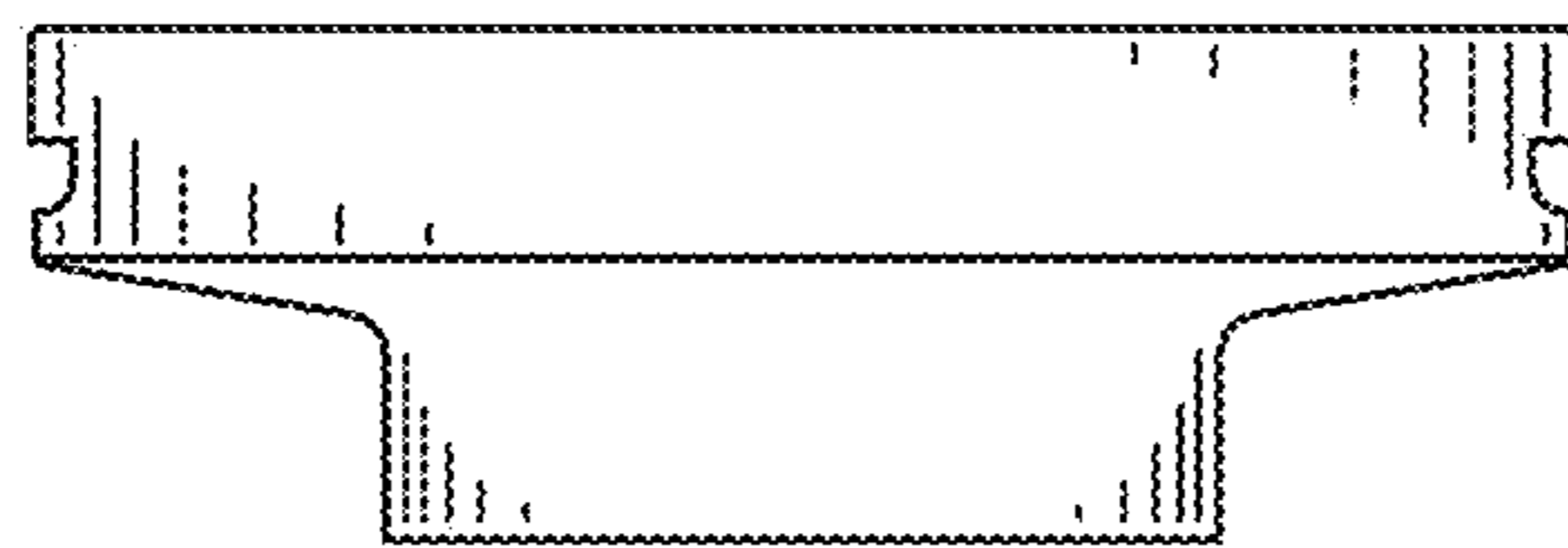

FIG. 12

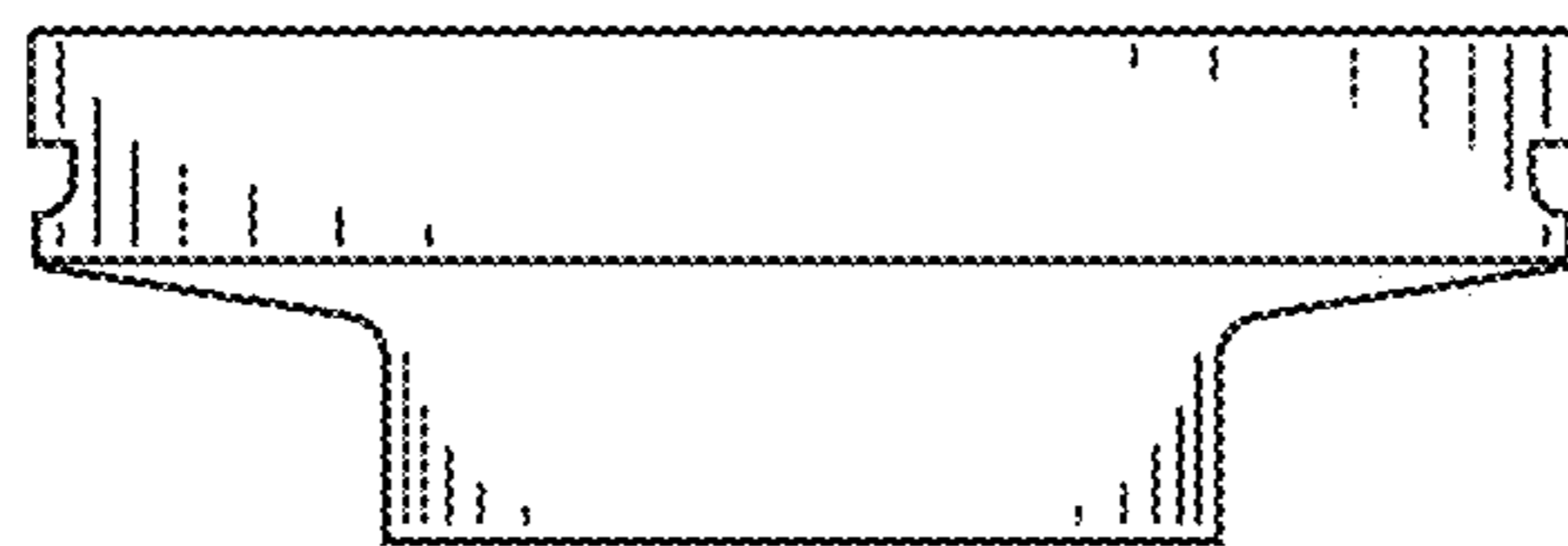

FIG. 13

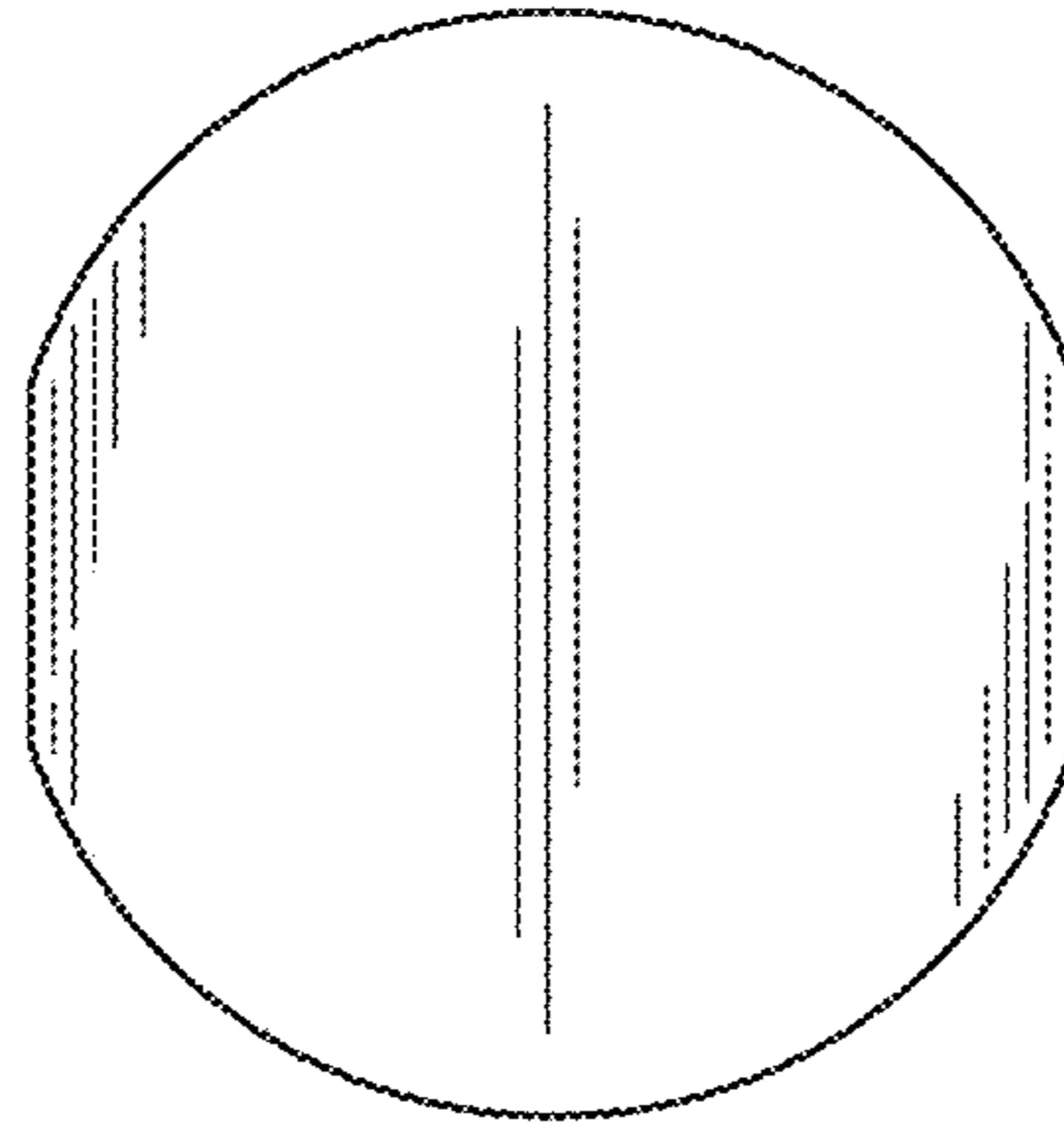

FIG. 14

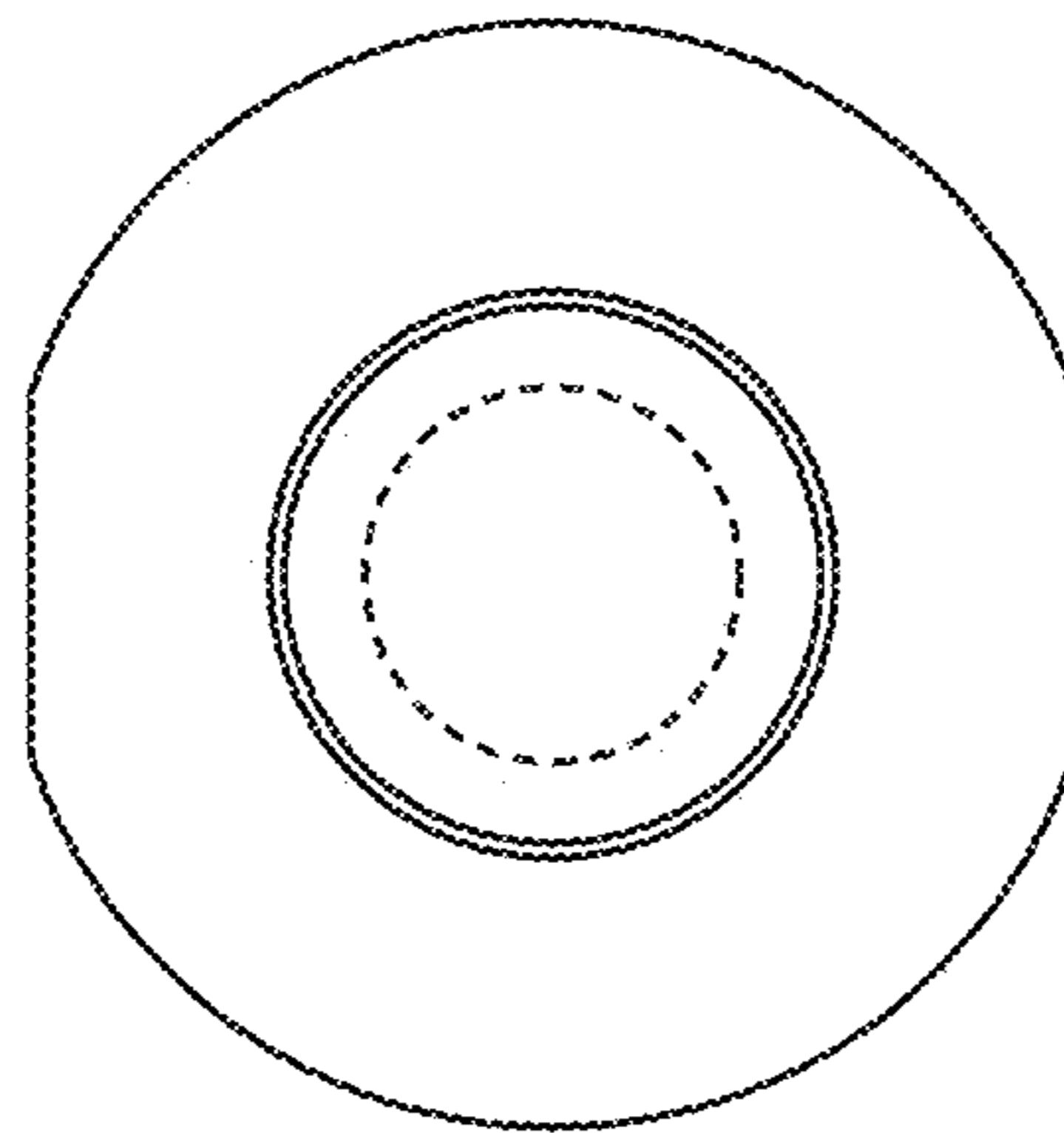

FIG. 15

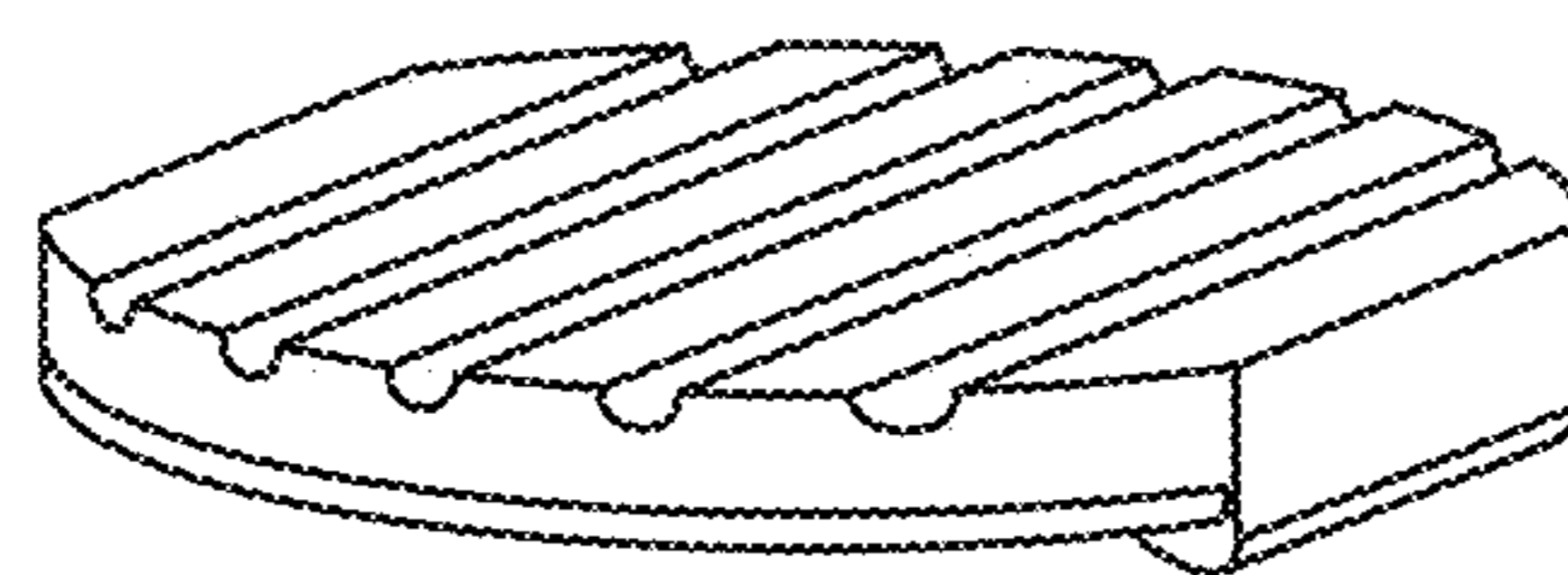

FIG. 16



FIG. 17



FIG. 18

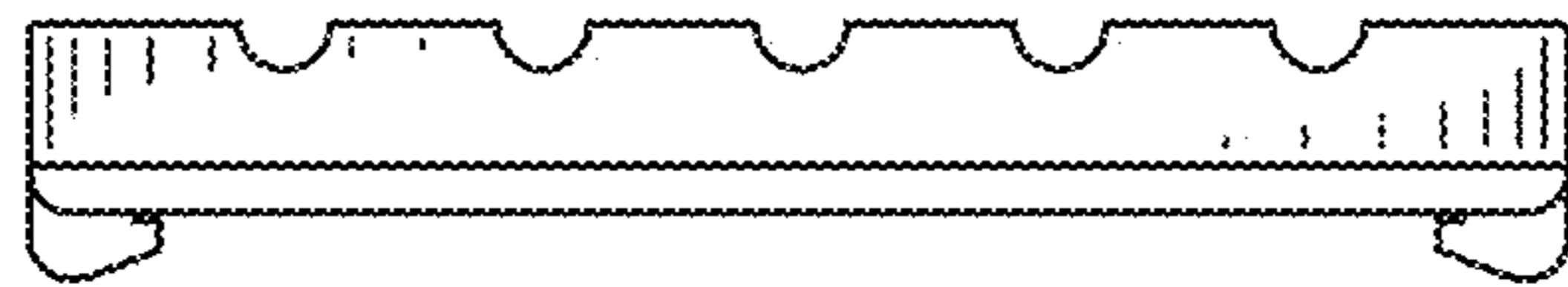

FIG. 19

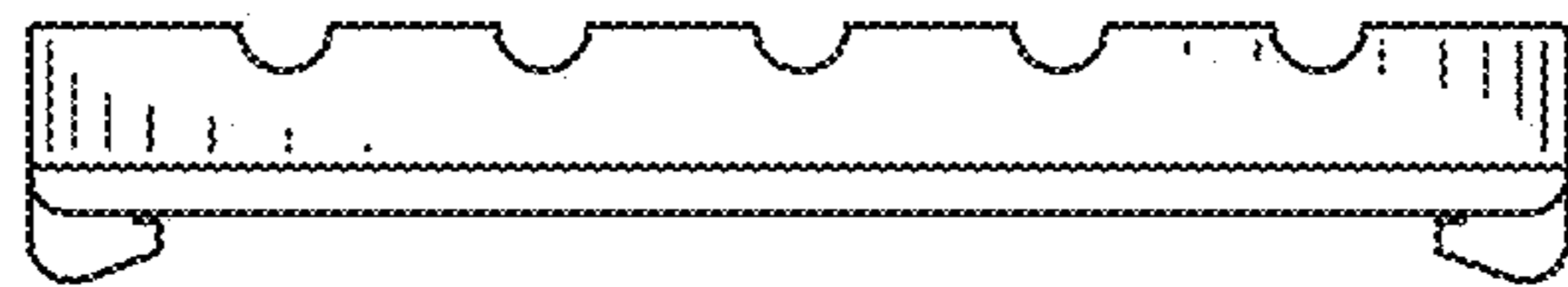

FIG. 20

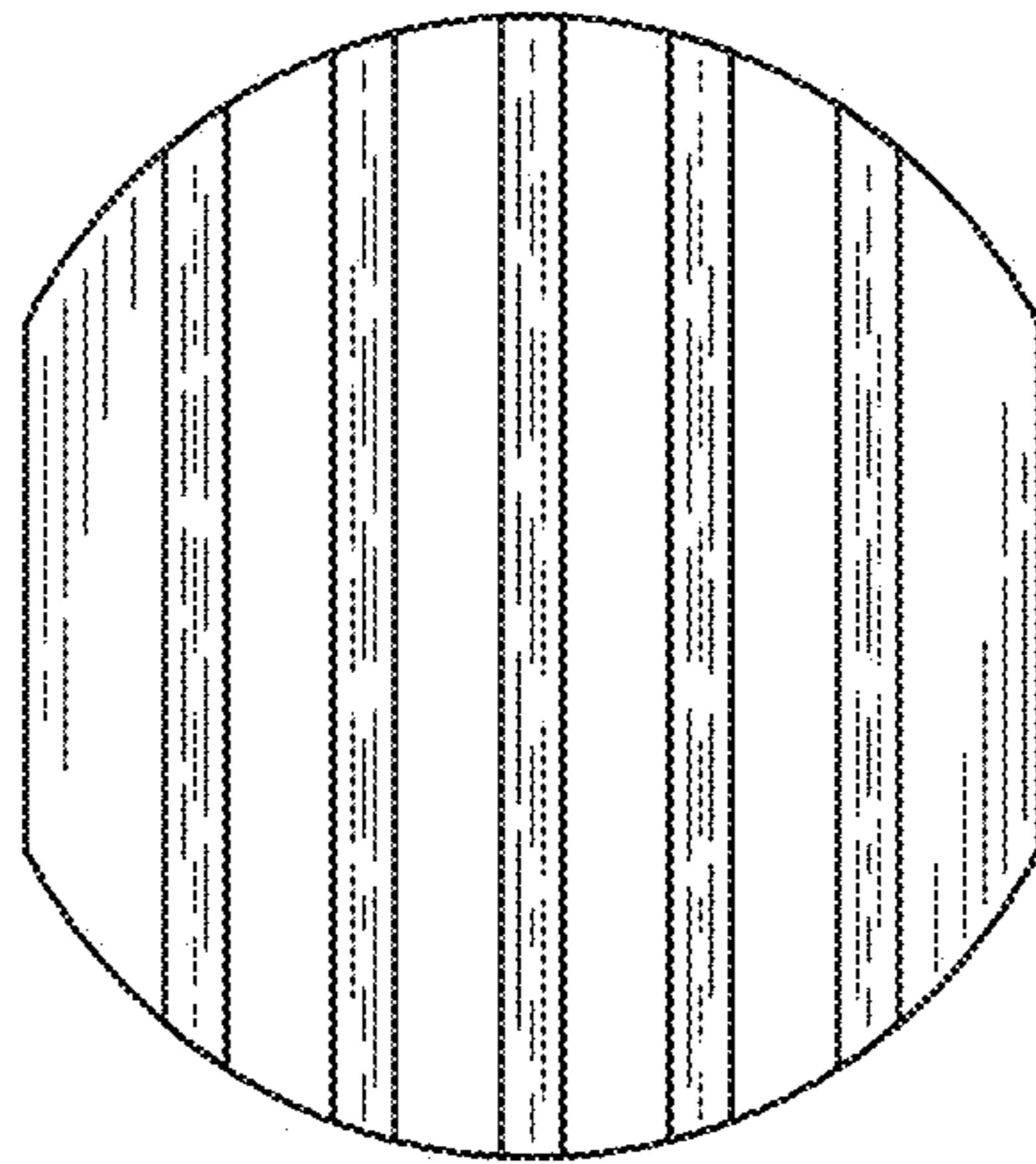

FIG. 21

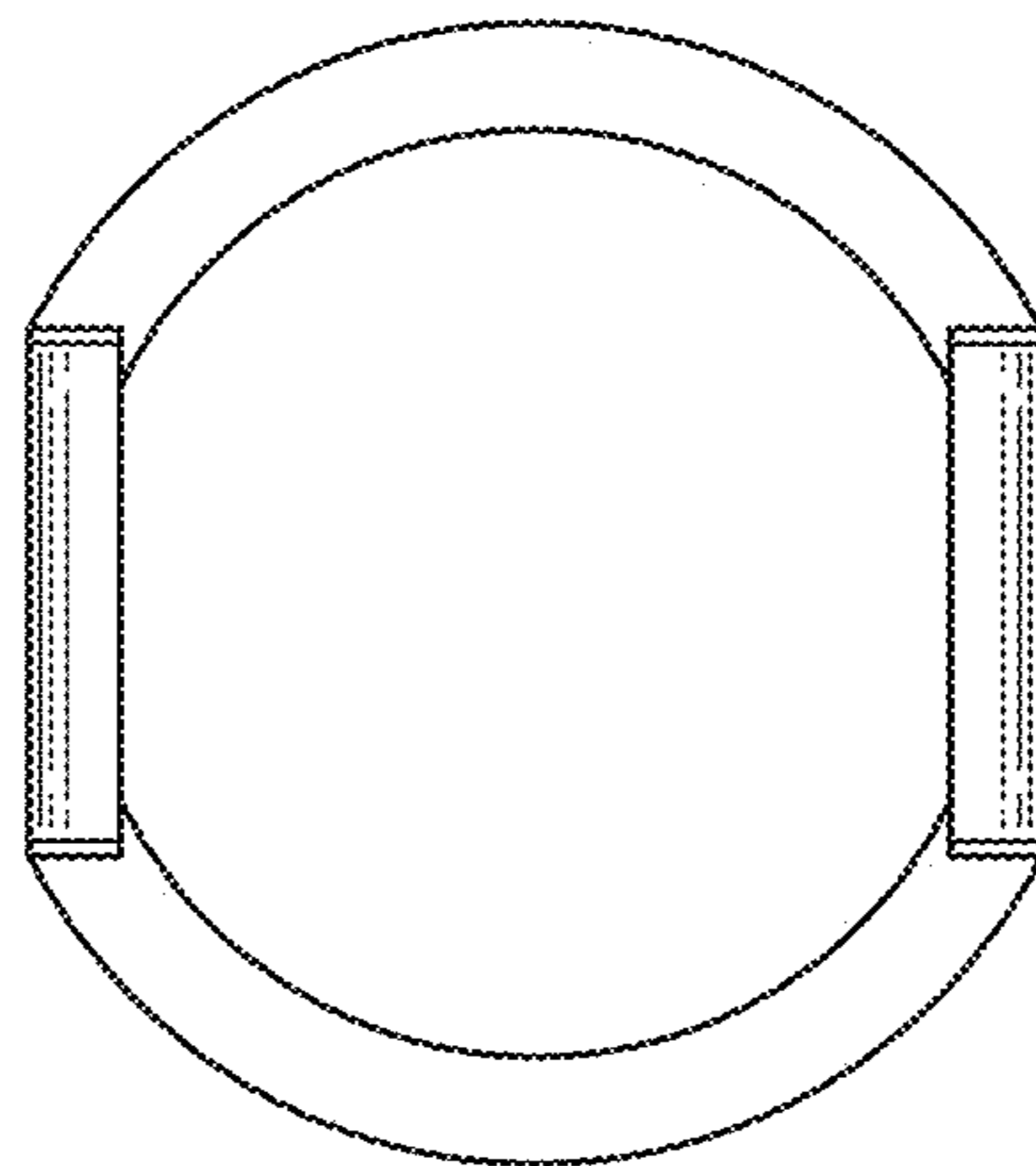

FIG. 22